



Is Now Part of



**ON Semiconductor®**

To learn more about ON Semiconductor, please visit our website at  
[www.onsemi.com](http://www.onsemi.com)

Please note: As part of the Fairchild Semiconductor integration, some of the Fairchild orderable part numbers will need to change in order to meet ON Semiconductor's system requirements. Since the ON Semiconductor product management systems do not have the ability to manage part nomenclature that utilizes an underscore (\_), the underscore (\_) in the Fairchild part numbers will be changed to a dash (-). This document may contain device numbers with an underscore (\_). Please check the ON Semiconductor website to verify the updated device numbers. The most current and up-to-date ordering information can be found at [www.onsemi.com](http://www.onsemi.com). Please email any questions regarding the system integration to [Fairchild\\_questions@onsemi.com](mailto:Fairchild_questions@onsemi.com).

ON Semiconductor and the ON Semiconductor logo are trademarks of Semiconductor Components Industries, LLC dba ON Semiconductor or its subsidiaries in the United States and/or other countries. ON Semiconductor owns the rights to a number of patents, trademarks, copyrights, trade secrets, and other intellectual property. A listing of ON Semiconductor's product/patent coverage may be accessed at [www.onsemi.com/site/pdf/Patent-Marking.pdf](http://www.onsemi.com/site/pdf/Patent-Marking.pdf). ON Semiconductor reserves the right to make changes without further notice to any products herein. ON Semiconductor makes no warranty, representation or guarantee regarding the suitability of its products for any particular purpose, nor does ON Semiconductor assume any liability arising out of the application or use of any product or circuit, and specifically disclaims any and all liability, including without limitation special, consequential or incidental damages. Buyer is responsible for its products and applications using ON Semiconductor products, including compliance with all laws, regulations and safety requirements or standards, regardless of any support or applications information provided by ON Semiconductor. "Typical" parameters which may be provided in ON Semiconductor data sheets and/or specifications can and do vary in different applications and actual performance may vary over time. All operating parameters, including "Typicals" must be validated for each customer application by customer's technical experts. ON Semiconductor does not convey any license under its patent rights nor the rights of others. ON Semiconductor products are not designed, intended, or authorized for use as a critical component in life support systems or any FDA Class 3 medical devices or medical devices with a same or similar classification in a foreign jurisdiction or any devices intended for implantation in the human body. Should Buyer purchase or use ON Semiconductor products for any such unintended or unauthorized application, Buyer shall indemnify and hold ON Semiconductor and its officers, employees, subsidiaries, affiliates, and distributors harmless against all claims, costs, damages, and expenses, and reasonable attorney fees arising out of, directly or indirectly, any claim of personal injury or death associated with such unintended or unauthorized use, even if such claim alleges that ON Semiconductor was negligent regarding the design or manufacture of the part. ON Semiconductor is an Equal Opportunity/Affirmative Action Employer. This literature is subject to all applicable copyright laws and is not for resale in any manner.

# FOD8001

## High Noise Immunity, 3.3V/5V Logic Gate Optocoupler

### Features

- High Noise Immunity characterized by Common Mode Rejection (CMR) and Power Supply Rejection (PSR) specifications
  - 20kV/μs Minimum Static CMR @  $V_{cm} = 1000V$
  - 25kV/μs Typical Dynamic CMR @  $V_{cm} = 1500V$ , 20Mbaud Rate
  - PSR in excess of 10% of the supply voltages across full operating bandwidth
- High Speed:
  - 25Mbit/sec Date Rate (NRZ)
  - 40ns max. Propagation Delay
  - 6ns max. Pulse Width Distortion
  - 20ns max. Propagation Delay Skew
- 3.3V and 5V CMOS Compatibility
- Extended industrial temperate range, -40°C to 105°C temperature range
- Safety and regulatory pending approvals:
  - UL1577, 3750 VACRMS for 1 min.
  - IEC60747-5-2 (pending)

### Applications

- Industrial fieldbus communications
  - Profibus, DeviceNet, CAN, RS485
- Programmable Logic Control
- Isolated Data Acquisition System

### Description

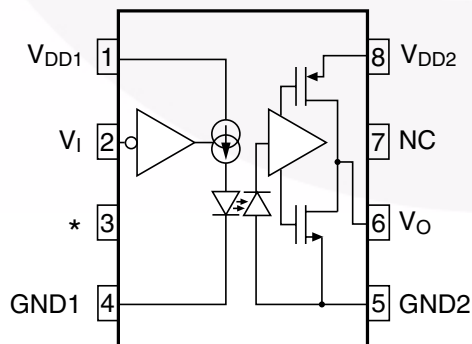
The FOD8001 is a 3.3V/5V high-speed logic gate Optocoupler, which supports isolated communications allowing digital signals to communicate between systems without conducting ground loops or hazardous voltages. It utilizes Fairchild's proprietary coplanar packaging technology, Optoplanar®, and optimized IC design to achieve high noise immunity, characterized by high common mode rejection and power supply rejection specifications.

This high-speed logic gate optocoupler, packaged in a compact 8-pin small outline package, consists of a high-speed AlGaAs LED driven by a CMOS buffer IC coupled to a CMOS detector IC. The detector IC comprises an integrated photodiode, a high-speed transimpedance amplifier and a voltage comparator with an output driver. The CMOS technology coupled to the high efficiency of the LED achieves low power consumption as well as very high speed (40ns propagation delay, 6ns pulse width distortion).

### Related Resources

- [www.fairchildsemi.com/products/opto/](http://www.fairchildsemi.com/products/opto/)
- [www.fairchildsemi.com/pf/FO/FOD0721.html](http://www.fairchildsemi.com/pf/FO/FOD0721.html)
- [www.fairchildsemi.com/pf/FO/FOD0720.html](http://www.fairchildsemi.com/pf/FO/FOD0720.html)
- [www.fairchildsemi.com/pf/FO/FOD0710.html](http://www.fairchildsemi.com/pf/FO/FOD0710.html)

### Functional Schematic



\*: Pin 3 must be left unconnected

Truth Table

$V_i$	LED	$V_o$
H	OFF	H
L	ON	L

## Pin Definitions

Pin Number	Pin Name	Pin Function Description
1	V <sub>DD1</sub>	Input Supply Voltage
2	V <sub>I</sub>	Input Data
3		LED Anode – Must be left unconnected
4	GND1	Input Ground
5	GND2	Output Ground
6	V <sub>O</sub>	Output Data
7	NC	Not Connected
8	V <sub>DD2</sub>	Output Supply Voltage

### Absolute Maximum Ratings (T<sub>A</sub> = 25°C Unless otherwise specified.)

Stresses exceeding the absolute maximum ratings may damage the device. The device may not function or be operable above the recommended operating conditions and stressing the parts to these levels is not recommended. In addition, extended exposure to stresses above the recommended operating conditions may affect device reliability. The absolute maximum ratings are stress ratings only.

Symbol	Parameter	Value	Units
T <sub>STG</sub>	Storage Temperature	-40 to +125	°C
T <sub>OPR</sub>	Operating Temperature	-40 to +105	°C
T <sub>SOL</sub>	Lead Solder Temperature (Refer to Reflow Temperature Profile)	260 for 10 sec	°C
V <sub>DD1</sub> , V <sub>DD2</sub>	Supply Voltage	0 to 6.0	V
V <sub>I</sub>	Input Voltage	-0.5 to V <sub>DD1</sub> + 0.5	V
I <sub>I</sub>	Input DC Current	-10 to +10	μA
V <sub>O</sub>	Output Voltage	-0.5 to V <sub>DD2</sub> + 0.5	V
I <sub>O</sub>	Average Output Current	10	mA
PD <sub>I</sub>	Input Power Dissipation <sup>(1)(3)</sup>	90	mW
PD <sub>O</sub>	Total Power Dissipation <sup>(2)(3)</sup>	70	mW

### Recommended Operating Conditions

The Recommended Operating Conditions table defines the conditions for actual device operation. Recommended operating conditions are specified to ensure optimal performance to the datasheet specifications. Fairchild does not recommend exceeding them or designing to absolute maximum ratings.

Symbol	Parameter	Min.	Max.	Unit
T <sub>A</sub>	Ambient Operating Temperature	-40	+105	°C
V <sub>DD1</sub> , V <sub>DD2</sub>	Supply Voltages (3.3V Operation) <sup>(4)</sup>	3.0	3.6	V
	Supply Voltages (5.0V Operation) <sup>(4)</sup>	4.5	5.5	
V <sub>IH</sub>	Logic High Input Voltage	2.0	V <sub>DD</sub>	V
V <sub>IL</sub>	Logic Low Input Voltage	0	0.8	V
t <sub>r</sub> , t <sub>f</sub>	Input Signal Rise and Fall Time		1.0	ms

#### Notes:

- Derate linearly from 25°C at a rate of tbd W/°C
- Derate linearly from 25°C at a rate of tbd mW/°C.
- Functional operation under these conditions is not implied. Permanent damage may occur if the device is subjected to conditions outside these ratings.
- 0.1μF bypass capacitor must be connected between Pin 1 and 4, and 5 and 8.

**Isolation Characteristics** (Apply over all recommended conditions, typical value is measured at  $T_A = 25^\circ\text{C}$ )

Symbol	Characteristics	Test Conditions	Min.	Typ.*	Max.	Unit
$V_{ISO}$	Input-Output Isolation Voltage	$f = 60\text{Hz}$ , $t = 1.0\text{ min}$ , $I_{I-O} \leq 10\mu\text{A}^{(5)(6)}$	3750	—	—	$V_{AC_{RMS}}$
$R_{ISO}$	Isolation Resistance	$V_{I-O} = 500\text{V}^{(5)}$	$10^{11}$	—	—	$\Omega$
$C_{ISO}$	Isolation Capacitance	$V_{I-O} = 0\text{V}$ , $f = 1.0\text{MHz}^{(5)}$	—	0.2	—	pF

**Notes:**

- Device is considered a two terminal device: Pins 1, 2, 3 and 4 are shorted together and Pins 5, 6, 7 and 8 are shorted together.
- $3,750 V_{AC_{RMS}}$  for 1 minute duration is equivalent to  $4,500 V_{AC_{RMS}}$  for 1 second duration.

**Electrical Characteristics** (Apply over all recommended conditions, typical value is measured at  $V_{DD1} = V_{DD2} = +3.3\text{V}$ ,  $V_{DD1} = +3.3\text{V}$  and  $V_{DD2} = +5.0\text{V}$ ,  $V_{DD1} = +5.0\text{V}$  and  $V_{DD2} = +3.3\text{V}$ ,  $V_{DD1} = V_{DD2} = +5.0\text{V}$ ,  $T_A = 25^\circ\text{C}$ )

Symbol	Parameter	Conditions	Min.	Typ.	Max.	Units
<b>INPUT CHARACTERISTICS</b>						
$I_{DD1L}$	Logic Low Input Supply Current	$V_I = 0\text{V}$		6.2	10.0	mA
$I_{DD1H}$	Logic High Input Supply Current	$V_I = V_{DD1}$		0.8	3.0	mA
$I_{IA}$ , $I_{IB}$	Input Current		-10		+10	$\mu\text{A}$
<b>OUTPUT CHARACTERISTICS</b>						
$I_{DD2L}$	Logic Low Output Supply Current	$V_I = 0\text{V}$		4.5	9.0	mA
$I_{DD2H}$	Logic High Output Supply Current	$V_I = V_{DD1}$		4.5	9.0	mA
$V_{OH}$	Logic High Output Voltage	$I_O = -20\mu\text{A}$ , $V_I = V_{IH}$ , $V_{DD2} = +3.3\text{V}$	2.9	3.3		V
		$I_O = -4\text{mA}$ , $V_I = V_{IH}$ , $V_{DD2} = +3.3\text{V}$	1.9	2.9		
		$I_O = -20\mu\text{A}$ , $V_I = V_{IH}$ , $V_{DD2} = +5.0\text{V}$	4.4	5.0		
		$I_O = -4\text{mA}$ , $V_I = V_{IH}$ , $V_{DD2} = +5.0\text{V}$	4.0	4.8		
VOL	Logic Low Output Voltage	$I_O = 20\mu\text{A}$ , $V_I = V_{IL}$		0	0.1	V
		$I_O = 4\text{mA}$ , $V_I = V_{IL}$		0.3	1.0	

**Switching Characteristics** (Apply over all recommended conditions, typical value is measured at  $V_{DD1} = V_{DD2} = +3.3V$ ,  $V_{DD1} = +3.3V$  and  $V_{DD2} = +5.0V$ ,  $V_{DD1} = +5.0V$  and  $V_{DD2} = +3.3V$ ,  $V_{DD1} = V_{DD2} = +5.0V$ ,  $T_A = 25^\circ C$ )

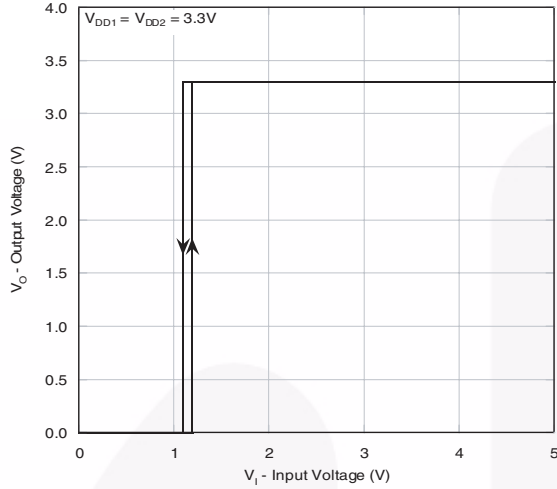
Symbol	Parameter	Test Conditions	Min.	Typ.	Max.	Unit
$t_{PHL}$	Propagation Delay Time to Logic Low Output	$C_L = 15pF$		25	40	ns
$t_{PLH}$	Propagation Delay Time to Logic High Output	$C_L = 15pF$		25	40	ns
PWD	Pulse Width Distortion, $ t_{PHL} - t_{PLH} $	PWD = 40ns, $C_L = 15pF$		2	6	ns
	Data Rate				25	Mb/s
$t_{PSK}$	Propagation Delay Skew	$C_L = 15pF^{(7)}$			20	ns
$t_R$	Output Rise Time (10%–90%)			6.5		ns
$t_F$	Output Fall Time (90%–10%)			6.5		ns
$ICM_{HI}$	Common Mode Transient Immunity at Output High	$V_I = V_{DD1}$ , $V_O > 0.8 V_{DD1}$ , $V_{CM} = 1000V^{(8)}$	20	40		kV/ $\mu s$
$ICM_{LI}$	Common Mode Transient Immunity at Output Low	$V_I = 0V$ , $V_O < 0.8V$ , $V_{CM} = 1000V^{(8)}$	20	40		kV/ $\mu s$
$C_{PDI}$	Input Dynamic Power Dissipation Capacitance <sup>(9)</sup>			30		pF
$C_{PDO}$	Output Dynamic Power Dissipation Capacitance <sup>(9)</sup>			3		pF

**Notes:**

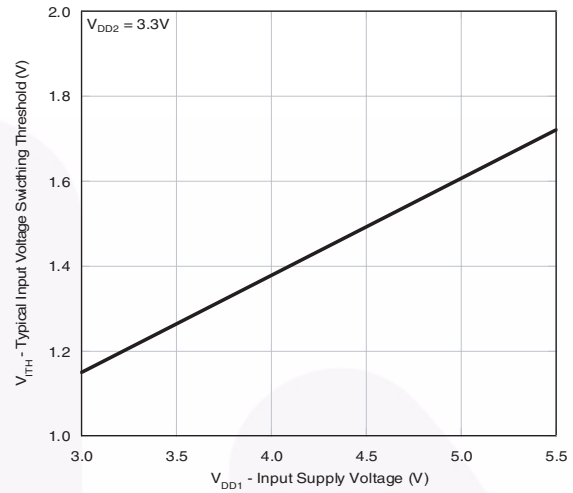
- $t_{PSK}$  is equal to the magnitude of the worst case difference in  $t_{PHL}$  and/or  $t_{PLH}$  that will be seen between units at any given temperature within the recommended operating conditions.
- Common mode transient immunity at output high is the maximum tolerable positive  $dV_{cm}/dt$  on the leading edge of the common mode impulse signal,  $V_{cm}$ , to assure that the output will remain high. Common mode transient immunity at output low is the maximum tolerable negative  $dV_{cm}/dt$  on the trailing edge of the common pulse signal,  $V_{cm}$ , to assure that the output will remain low.
- Unloaded dynamic power dissipation is calculated as follows:  
 $C_{PD} \times V_{DD} \times f + I_{DD} + V_{PD}$  where  $f$  is switched time in MHz.

## Typical Performance Curves

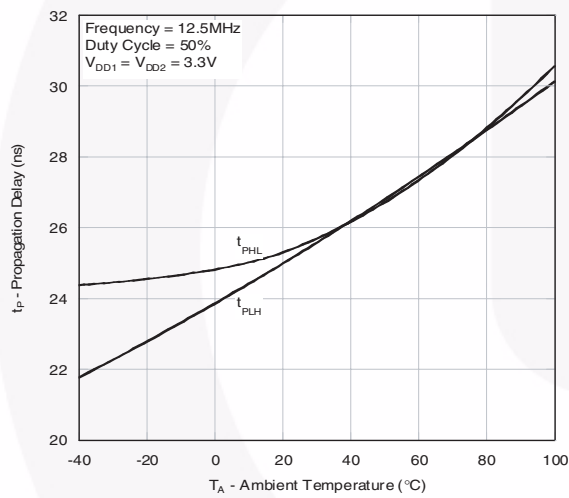
**Figure 1. Typical Output Voltage vs. Input Voltage**



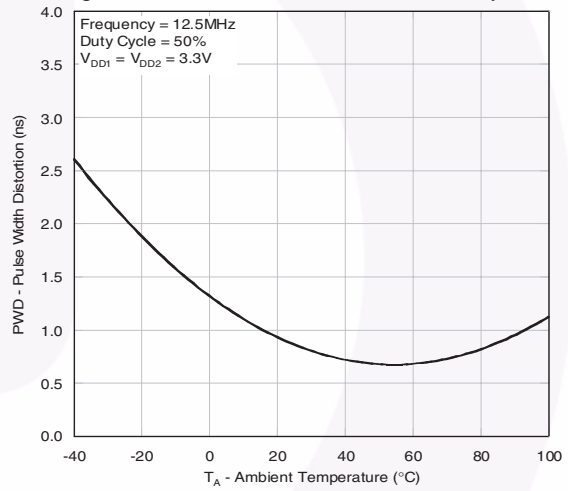
**Figure 2. Input Voltage Switching Threshold vs. Input Supply Voltage**



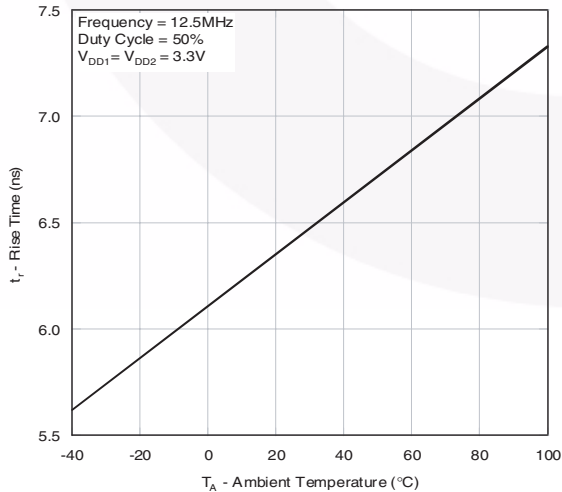
**Figure 3. Propagation Delay vs. Ambient Temperature**



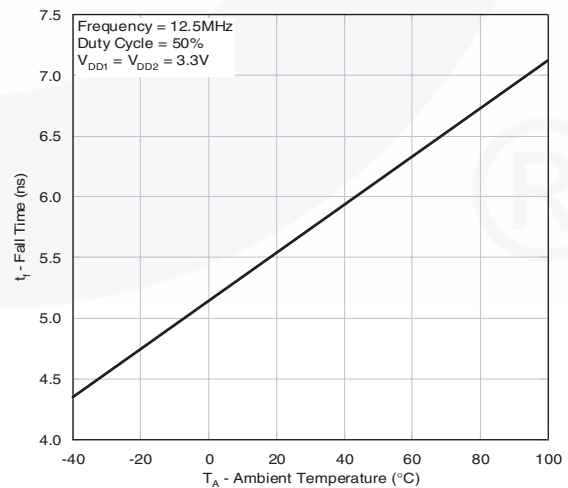
**Figure 4. Pulse Width Distortion vs. Ambient Temperature**



**Figure 5. Typical Rise Time vs. Ambient Temperature**

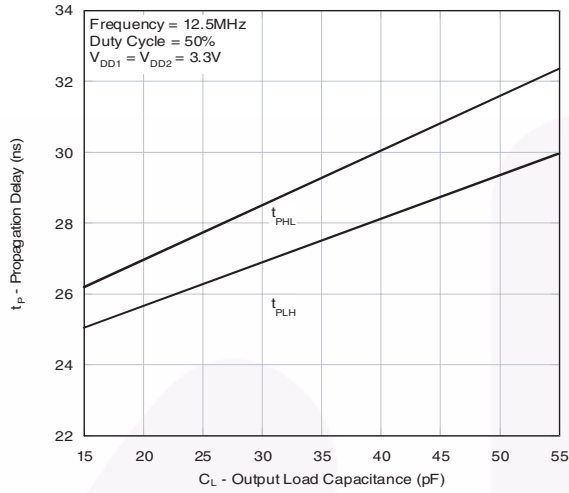


**Figure 6. Typical Fall Time vs. Ambient Temperature**

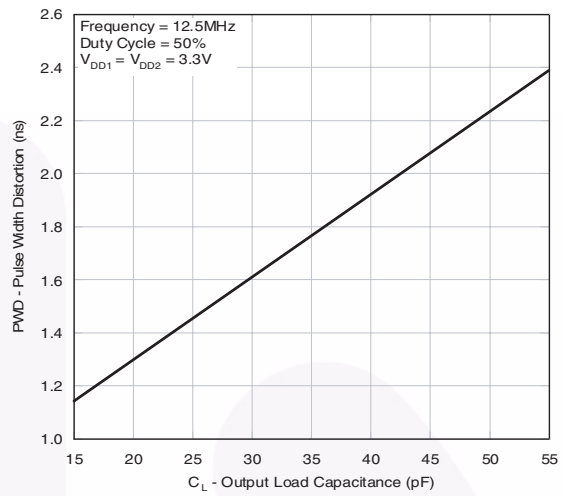


## Typical Performance Curves (Continued)

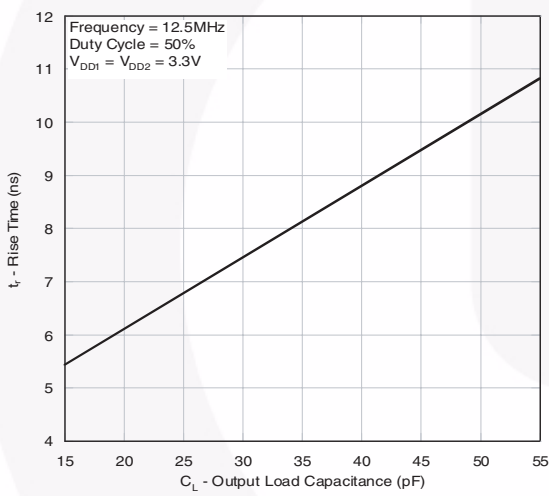
**Figure 7. Typical Propagation Delay vs. Output Load Capacitance**



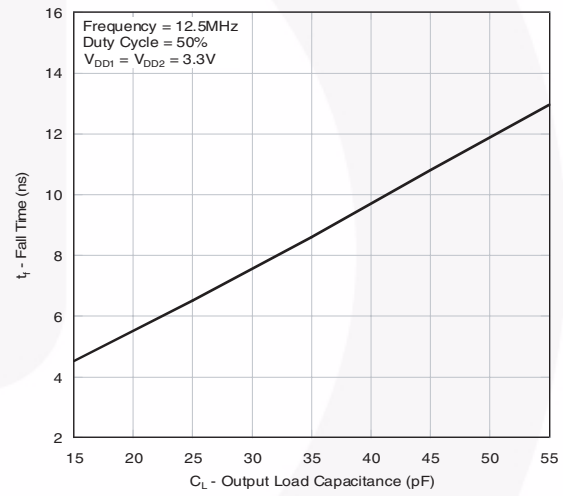
**Figure 8. Typical Width Distortion vs. Output Load Capacitance**



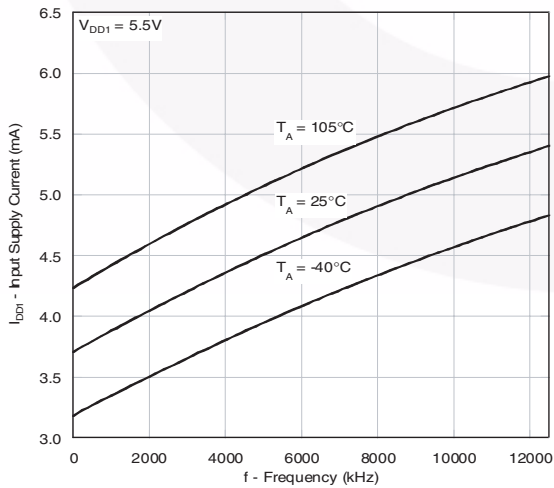
**Figure 9. Typical Rise Time vs. Output Load Capacitance**



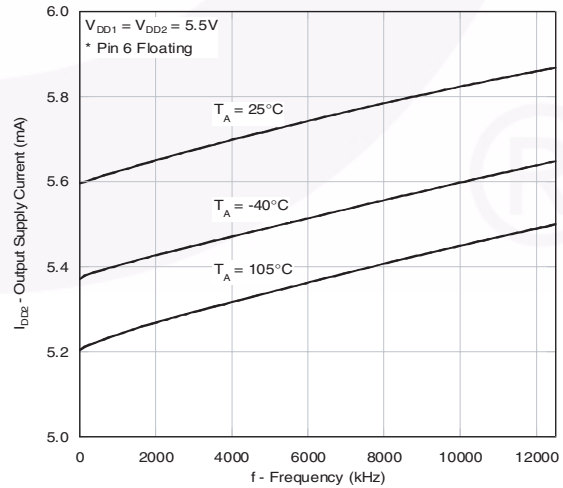
**Figure 10. Typical Fall Time vs. Output Load Capacitance**



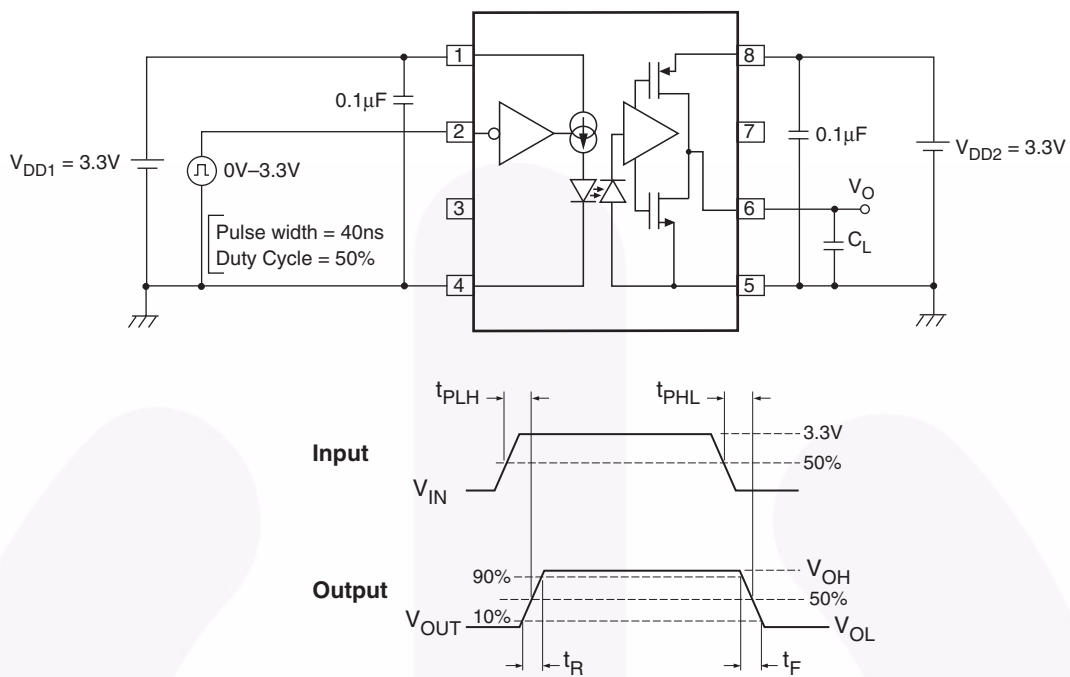
**Figure 11. Input Supply Current vs. Frequency**



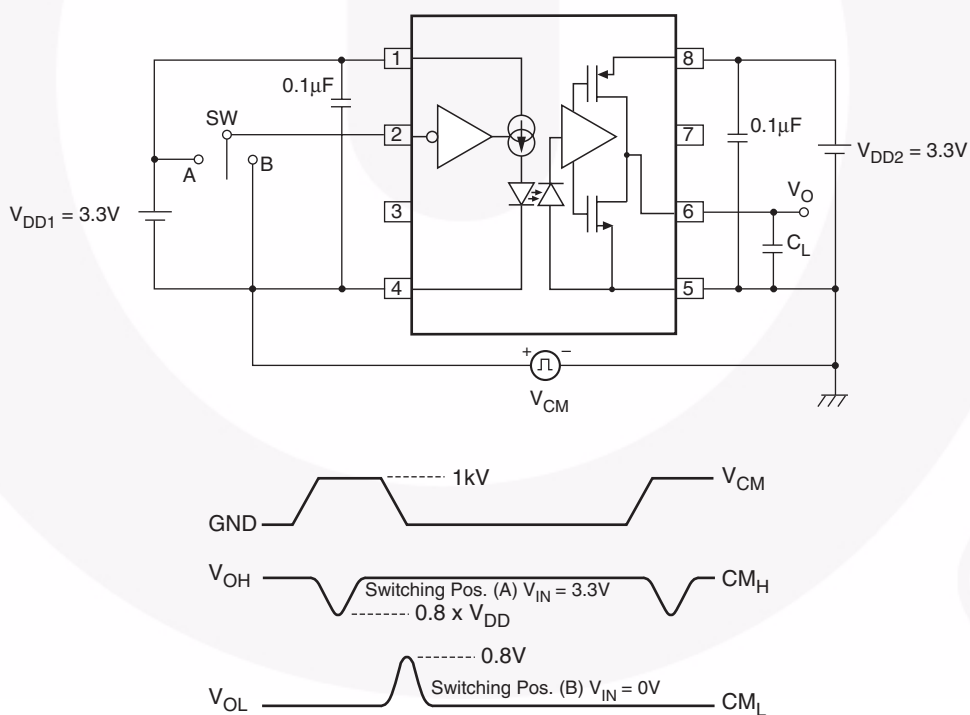
**Figure 12. Output Supply Current vs. Frequency**



### Test Circuits



**Figure 13. Test Circuit for Propagation Delay Time and Rise Time, Fall Time**



**Figure 14. Test Circuit for Instantaneous Common Mode Rejection Voltage**

## Application Information

Noise is defined as any unwanted signal that degrades or interferes with the operation of a system or circuit. Input-output noise rejection is a key characteristic of an optocoupler, and the performance specification for this noise rejection is called, “Common Mode Transient Immunity or Common Mode Rejection, CMR”. The CMR test configuration is presented in high speed optocoupler datasheets, which tests the optocoupler to a specified rate of interfering signal (dv/dt), at a specified peak voltage ( $V_{cm}$ ).

This defined noise signal is applied to the test device while the coupler is a stable logic high or logic low state. This test procedure evaluates the interface device in a constant or static logic state. This type of CMR can be referred to as “**Static CMR**”. Fairchild’s high speed optocouplers, which use an optically transparent, electrically conductive shield, and offer active totem pole logic output have static CMR in excess of 50KV/us at peak amplitudes of 1.5kV to 2.0kV.

### Dynamic Common Mode Rejection

The noise susceptibility of an interface while it is actively transferring data is a common requirement in serial data communication. However, the static CMR specification is not adequate in quantifying the electrical noise susceptibility for optocouplers used in isolating high speed data transfer.

A serial data communication network’s noise performance is usually quantified as the number of bit errors per second or as a ratio of the number of bits transmitted in a specified time frame. This describes Bit Error Rate, BER. Test equipment that evaluates BER is called a Bit Error Rate Tester, BERT. When a BERT system is combined with a CMR tester, the active or dynamic noise rejection of an isolated interface can then be quantified. This type of CMR is thus defined as “**Dynamic CMR**”. Therefore, evaluating the common mode rejection while the optocoupler is switching at high speed represents a realistic approach to understand noise interference.

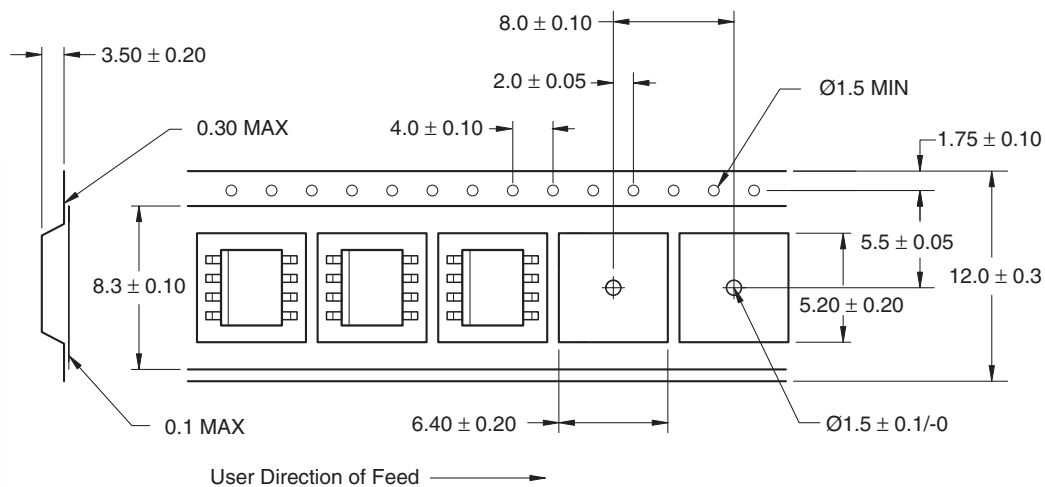
Test circuit functions were built to interface a commercial pseudo-random bit sequence (PRBS) generator and error detector with a pair of high speed optocouplers, FOD8001, connected in a loop-back configuration. With a 10MBaud PRBS serial data stream, no error was detected until the common mode voltage rose above 2.5kV with a dv/dt of 45kV/us. And increasing the data rate beyond 10Mbaud, the test was conducted at 20MBaud, and no error was detected at dv/dt of 25kV/us at common mode voltage of 1.5kV.

The test data for the dynamic CMR is comparable or better than the static CMR specifications found in the datasheet. These excellent noise rejection performances are results of the innovative circuit design and the proprietary coplanar assembly process.

### Power Supply Noise Rejection

High levels of electrical noise can cause the optocoupler to register the incorrect logic state. The most commonly discussed noise signal is the common mode noise found between the input and output of the optocoupler. However, common mode noise is not the only path of noise into the input or output of the optocoupler. Due to the high gain and wide bandwidth of the transimpedance amplifier used for the photo detector circuits, power supply noise can cause the optocoupler to change state independent of the LED operation. Power supply noise is typically characterized as either random or periodic pulses with varying amplitudes and rates of rise and fall. The necessary tests have been conducted to understand the influence of the power supply noise and its effect of the proper operation of the FOD8001. The optocoupler under test offered power supply noise rejection in excess of 10% of the supply voltage for a frequency ranging from 100kHz to 35MHz, for logic high and logic low states.

## Carrier Tape Specification



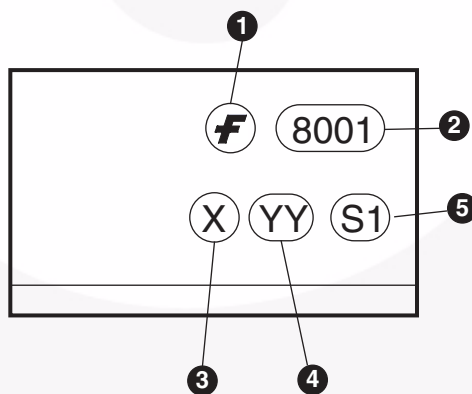
**Note:**  
All dimensions are in millimeters.

## Ordering Information

Option	Order Entry Identifier	Description
No Suffix	FOD8001	Small outline 8-pin, shipped in tubes (50 units per tube)
R2	FOD8001R2	Small outline 8-pin, tape and reel (2,500 units per reel)

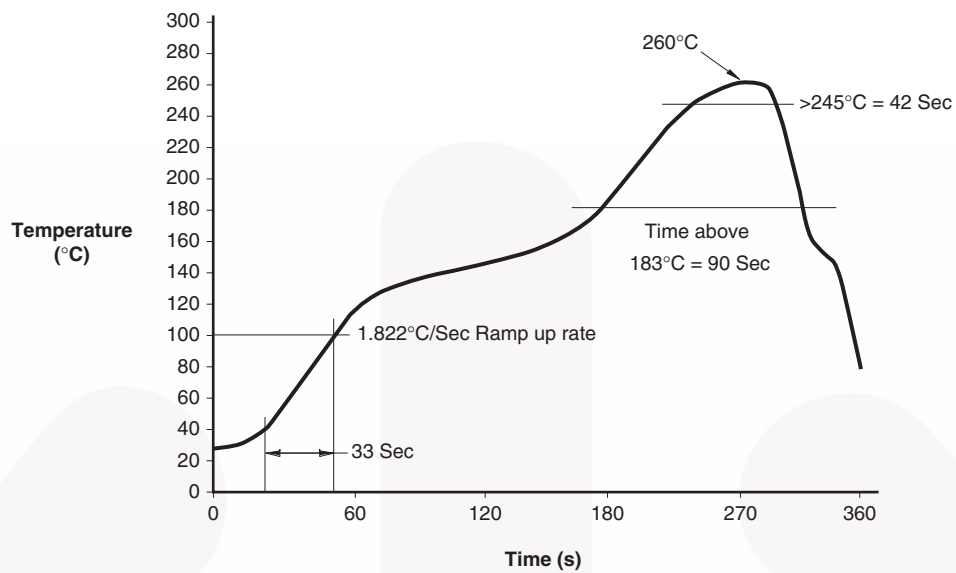
All packages are lead free per JEDEC: J-STD-020B standard.

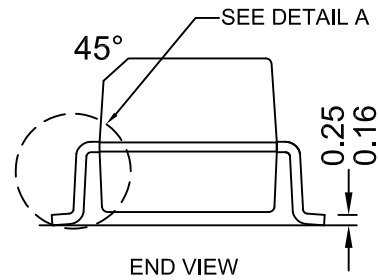
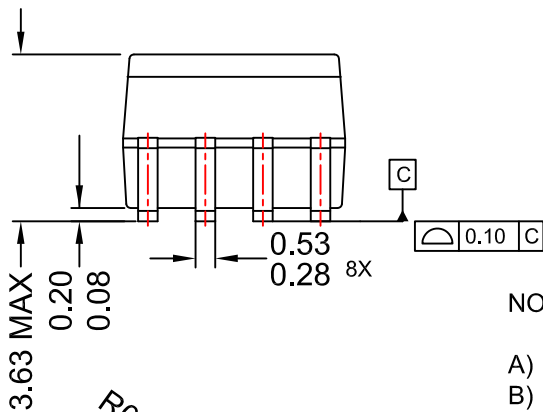
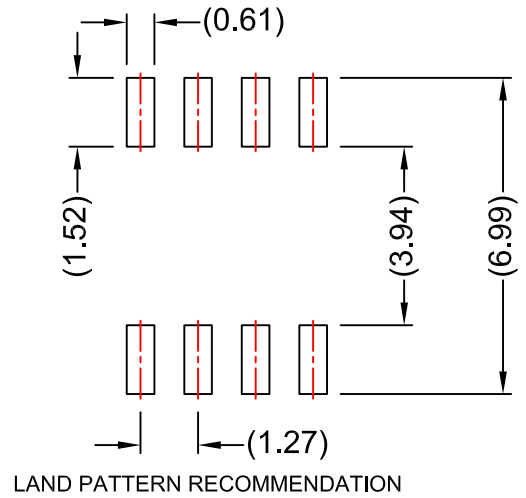
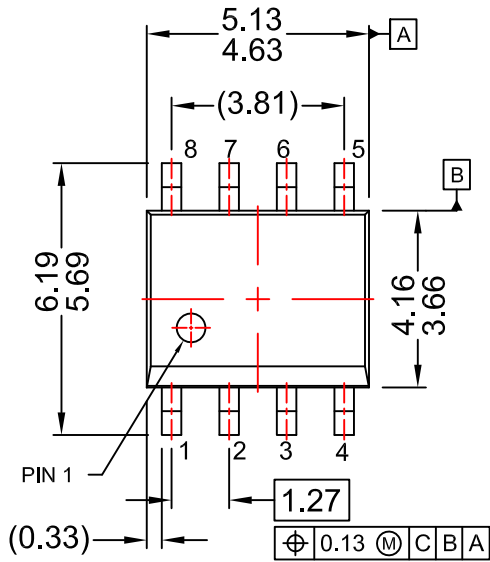
## Marking Information



Definitions	
1	Fairchild logo
2	Device number
3	One digit year code, e.g., '8'
4	Two digit work week ranging from '01' to '53'
5	Assembly package code

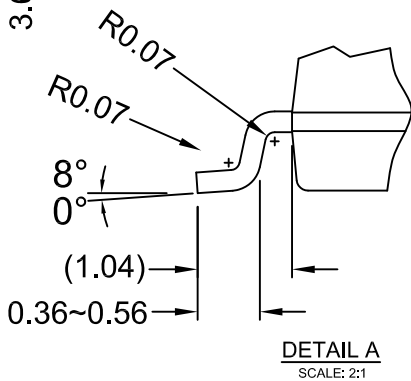
### Reflow Profile





NOTES:

- A) NO STANDARD APPLIES TO THIS PACKAGE
- B) ALL DIMENSIONS ARE IN MILLIMETERS.
- C) DIMENSIONS DO NOT INCLUDE MOLD FLASH OR BURRS.
- D) LANDPATTERN STANDARD: SOIC127P600X175-8M.
- E) DRAWING FILENAME: MKT-M08Erev5



ON Semiconductor and  are trademarks of Semiconductor Components Industries, LLC dba ON Semiconductor or its subsidiaries in the United States and/or other countries. ON Semiconductor owns the rights to a number of patents, trademarks, copyrights, trade secrets, and other intellectual property. A listing of ON Semiconductor's product/patent coverage may be accessed at [www.onsemi.com/site/pdf/Patent-Marking.pdf](http://www.onsemi.com/site/pdf/Patent-Marking.pdf). ON Semiconductor reserves the right to make changes without further notice to any products herein. ON Semiconductor makes no warranty, representation or guarantee regarding the suitability of its products for any particular purpose, nor does ON Semiconductor assume any liability arising out of the application or use of any product or circuit, and specifically disclaims any and all liability, including without limitation special, consequential or incidental damages. Buyer is responsible for its products and applications using ON Semiconductor products, including compliance with all laws, regulations and safety requirements or standards, regardless of any support or applications information provided by ON Semiconductor. "Typical" parameters which may be provided in ON Semiconductor data sheets and/or specifications can and do vary in different applications and actual performance may vary over time. All operating parameters, including "Typicals" must be validated for each customer application by customer's technical experts. ON Semiconductor does not convey any license under its patent rights nor the rights of others. ON Semiconductor products are not designed, intended, or authorized for use as a critical component in life support systems or any FDA Class 3 medical devices or medical devices with a same or similar classification in a foreign jurisdiction or any devices intended for implantation in the human body. Should Buyer purchase or use ON Semiconductor products for any such unintended or unauthorized application, Buyer shall indemnify and hold ON Semiconductor and its officers, employees, subsidiaries, affiliates, and distributors harmless against all claims, costs, damages, and expenses, and reasonable attorney fees arising out of, directly or indirectly, any claim of personal injury or death associated with such unintended or unauthorized use, even if such claim alleges that ON Semiconductor was negligent regarding the design or manufacture of the part. ON Semiconductor is an Equal Opportunity/Affirmative Action Employer. This literature is subject to all applicable copyright laws and is not for resale in any manner.

## PUBLICATION ORDERING INFORMATION

### LITERATURE FULFILLMENT:



Literature Distribution Center for ON Semiconductor  
19521 E. 32nd Pkwy, Aurora, Colorado 80011 USA  
**Phone:** 303-675-2175 or 800-344-3860 Toll Free USA/Canada  
**Fax:** 303-675-2176 or 800-344-3867 Toll Free USA/Canada  
**Email:** [orderlit@onsemi.com](mailto:orderlit@onsemi.com)

**N. American Technical Support:** 800-282-9855 Toll Free  
USA/Canada  
**Europe, Middle East and Africa Technical Support:**  
Phone: 421 33 790 2910  
**Japan Customer Focus Center**  
Phone: 81-3-5817-1050

**ON Semiconductor Website:** [www.onsemi.com](http://www.onsemi.com)  
**Order Literature:** <http://www.onsemi.com/orderlit>  
For additional information, please contact your local  
Sales Representative

## Looking for pricing, stock, or lifecycle information?

Click below to explore more details on WIN SOURCE:

-  [View FOD8001 on WIN SOURCE](#)
-  [Fairchild/ON Semiconductor Information](#)

## Optimize Your Supply Chain with WIN SOURCE Solutions

-  Global Sourcing Solution
-  Obsolete Management
-  Cost Control Management
-  Shortage Management
-  Alternative Solution
-  Excess Inventory Management