



**THE DATASHEET OF
CSD95372BQ5MCT**



CSD95372BQ5MC Synchronous Buck NexFET™ Smart Power Stage

1 Features

- 60-A Continuous Operating Current Capability
- 93.4% System Efficiency at 30 A
- Low Power Loss of 2.8 W at 30 A
- High-Frequency Operation (up to 1.25 MHz)
- Diode Emulation Mode With FCCM
- Temperature-Compensated Bidirectional Current Sense
- Analog Temperature Output (600 mV at 0°C)
- Fault Monitoring
 - High-Side Short, Overcurrent, and Overtemperature Protection
- 3.3-V and 5-V PWM Signal Compatible
- Tri-State PWM Input
- Integrated Bootstrap Diode
- Optimized Deadtime for Shoot-Through Protection
- High-Density SON 5 × 6 mm Footprint
- Ultra-Low Inductance Package
- System-Optimized PCB Footprint
- DualCool™ Packaging
- RoHS Compliant – Lead-Free Terminal Plating
- Halogen-Free

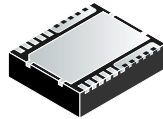

Application Diagram

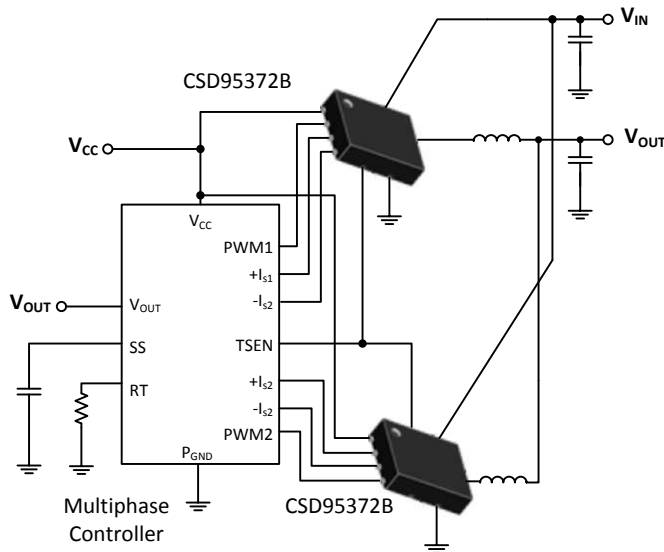

2 Applications

- Multiphase Synchronous Buck Converters
 - High-Frequency Applications
 - High-Current, Low Duty-Cycle Applications
- POL DC-DC Converters
- Memory and Graphic Cards
- Desktop and Server VR11.x / VR12.x V-Core and Memory Synchronous Converters

3 Description

The CSD95372BQ5MC NexFET™ smart power stage is a highly optimized design for use in a high-power, high-density synchronous buck converter. This product integrates the driver IC and Power MOSFETs to complete the power stage switching function. This combination produces high-current, high-efficiency, and high-speed switching capability in a small 5 mm × 6 mm outline package. It also integrates the accurate current sensing system and temperature sensing functionality to simplify system design and improve accuracy. In addition, the PCB footprint is optimized to help reduce design time and simplify the completion of the overall system design.

Device Information⁽¹⁾

DEVICE	MEDIA	QTY	PACKAGE	SHIP
CSD95372BQ5MC	13-Inch Reel	2500	SON 5 × 6 mm DualCool Package	Tape and Reel
CSD95372BQ5MCT	7-Inch Reel	250		

(1) For all available packages, see the orderable addendum at the end of the data sheet.

Typical Power Stage Efficiency and Power Loss

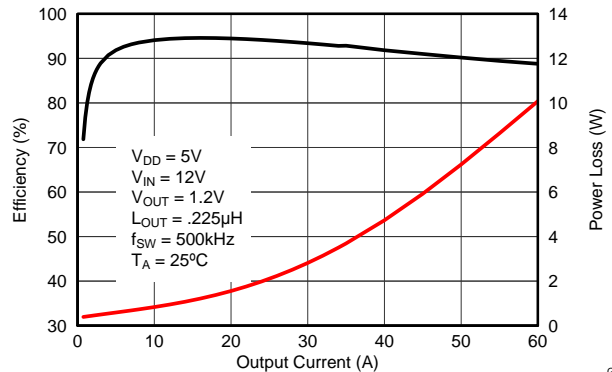

G001



Table of Contents

1 Features	1	7 Application Schematic	5
2 Applications	1	8 Device and Documentation Support	6
3 Description	1	8.1 Community Resources	6
4 Revision History	2	8.2 Trademarks	6
5 Pin Configuration and Functions	3	8.3 Electrostatic Discharge Caution	6
6 Specifications	4	8.4 Glossary	6
6.1 Absolute Maximum Ratings	4	9 Mechanical, Packaging, and Orderable Information	7
6.2 ESD Ratings	4	9.1 Mechanical Drawing	7
6.3 Recommended Operating Conditions	4	9.2 Recommended PCB Land Pattern	8
6.4 Thermal Information	4	9.3 Recommended Stencil Opening	8

4 Revision History

NOTE: Page numbers for previous revisions may differ from page numbers in the current version.

Changes from Original (April 2014) to Revision A	Page
• Updated Application Schematic to show I_{OUT} (not I_{MON}) for each CSD95372B	5
• Corrected MAX A dimensions in Mechanical Drawing table to 1.050 mm (0.041 inch)	7

6 Specifications

6.1 Absolute Maximum Ratings

 $T_A = 25^\circ\text{C}$ (unless otherwise noted)⁽¹⁾

	MIN	MAX	UNIT
V_{IN} to P_{GND}	-0.3	25	V
V_{IN} to V_{SW}	-0.3	25	V
V_{IN} to V_{SW} (10 ns)	-7	27	V
V_{SW} to P_{GND}	-0.3	20	V
V_{SW} to P_{GND} (10 ns)	-7	23	V
V_{DD} to P_{GND}	-0.3	7	V
ENABLE, PWM, FCCM, TAO, IOUT, REFIN to P_{GND}	-0.3	$V_{DD} + 0.3\text{ V}$	V
BOOT to BOOT_R ⁽²⁾	-0.3	$V_{DD} + 0.3\text{ V}$	V
P_D Power dissipation		12	W
T_J Operating junction	-55	150	$^\circ\text{C}$
T_{stg} Storage temperature	-55	150	$^\circ\text{C}$

- (1) Stresses beyond those listed under *Absolute Maximum Ratings* may cause permanent damage to the device. These are stress ratings only, which do not imply functional operation of the device at these or any other conditions beyond those indicated under *Recommended Operating Conditions*. Exposure to absolute-maximum-rated conditions for extended periods may affect device reliability.
- (2) Should not exceed 7 V

6.2 ESD Ratings

	VALUE	UNIT
$V_{(ESD)}$ Electrostatic discharge	Human body model (HBM)	± 2000
	Charged device model (CDM)	± 500
		V

6.3 Recommended Operating Conditions

 $T_A = 25^\circ$ (unless otherwise noted)

	MIN	MAX	UNIT
V_{DD} Gate drive voltage	4.5	5.5	V
V_{IN} Input supply voltage ⁽¹⁾		16	V
V_{OUT} Output voltage		5.5	V
I_{OUT} Continuous output current	$V_{IN} = 12\text{ V}$, $V_{DD} = 5\text{ V}$, $V_{OUT} = 3.3\text{ V}$, $f_{SW} = 500\text{ kHz}$, $L_{OUT} = 0.47\text{ }\mu\text{H}$ ⁽²⁾	60	A
I_{OUT-PK} Peak output current ⁽³⁾		90	A
f_{SW} Switching frequency	$C_{BST} = 0.1\text{ }\mu\text{F}$ (min)	1250	kHz
On time duty cycle	$f_{SW} = 1\text{ MHz}$	85%	
Minimum PWM on time	40		ns
Operating temperature	-40	125	$^\circ\text{C}$

- (1) Operating at high V_{IN} can create excessive AC voltage overshoots on the switch node (V_{SW}) during MOSFET switching transients. For reliable operation, the switch node (V_{SW}) to ground voltage must remain at or below the Absolute Maximum Ratings.
- (2) Measurement made with six 10- μF (TDK C3216X5R1C106KT or equivalent) ceramic capacitors placed across V_{IN} to P_{GND} pins.
- (3) System conditions as defined in Note 1. Peak Output Current is applied for $t_p = 50\text{ }\mu\text{s}$

6.4 Thermal Information

 $T_A = 25^\circ\text{C}$ (unless otherwise noted)

THERMAL METRIC	MIN	TYP	MAX	UNIT
$R_{\theta JC(top)}$ Junction-to-case (top of package) thermal resistance ⁽¹⁾			5	$^\circ\text{C/W}$
$R_{\theta JB}$ Junction-to-board thermal resistance ⁽²⁾			1.5	$^\circ\text{C/W}$

- (1) $R_{\theta JC(top)}$ is determined with the device mounted on a 1 inch² (6.45 cm²), 2-oz (0.071 mm thick) Cu pad on a 1.5 inches x 1.5 inches, 0.06-inch (1.52 mm) thick FR4 board.
- (2) $R_{\theta JB}$ value based on hottest board temperature within 1 mm of the package.

7 Application Schematic

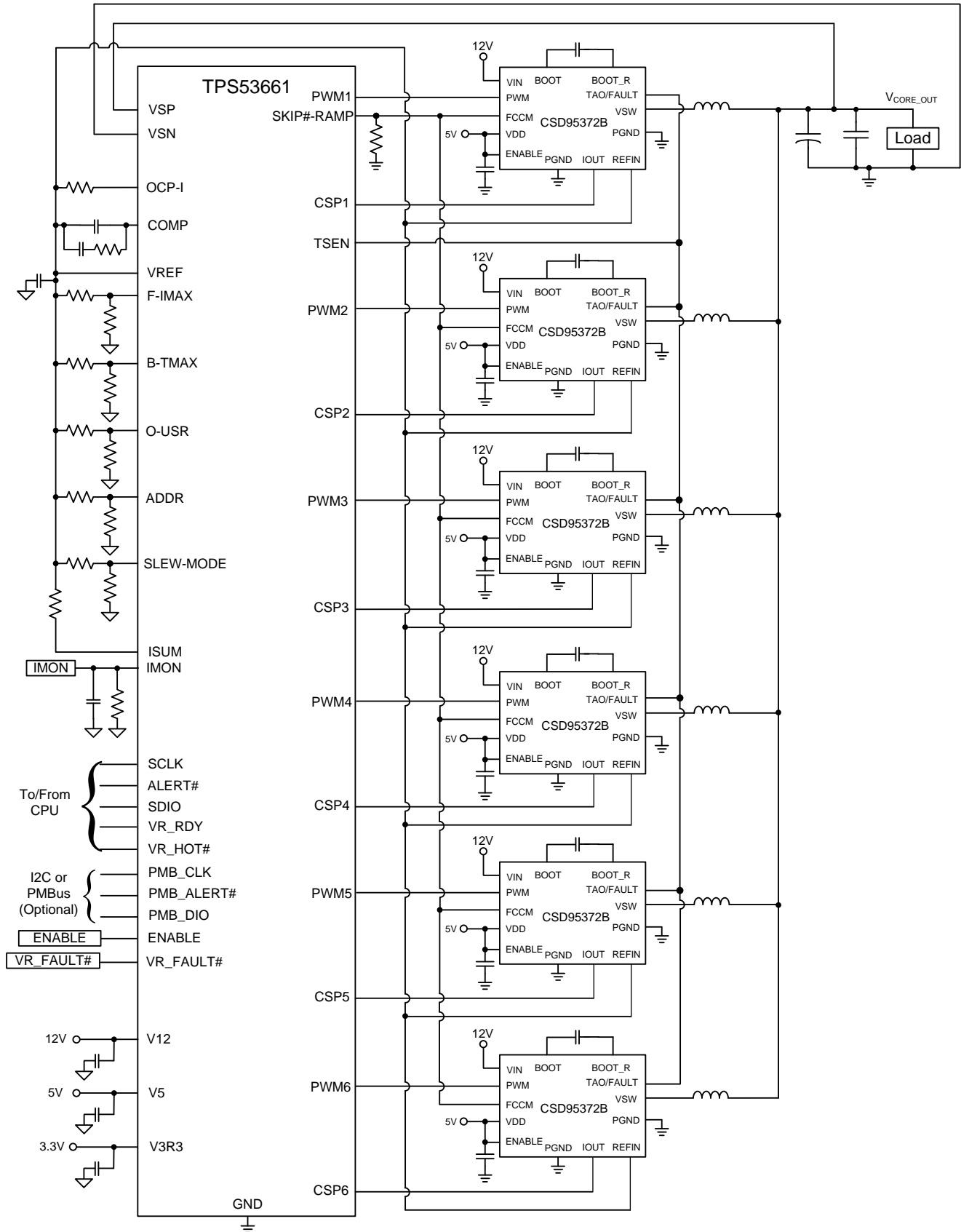

8 Device and Documentation Support

8.1 Community Resources

The following links connect to TI community resources. Linked contents are provided "AS IS" by the respective contributors. They do not constitute TI specifications and do not necessarily reflect TI's views; see TI's [Terms of Use](#).

TI E2E™ Online Community *TI's Engineer-to-Engineer (E2E) Community*. Created to foster collaboration among engineers. At e2e.ti.com, you can ask questions, share knowledge, explore ideas and help solve problems with fellow engineers.

Design Support *TI's Design Support* Quickly find helpful E2E forums along with design support tools and contact information for technical support.

8.2 Trademarks

DualCool, NexFET, E2E are trademarks of Texas Instruments. All other trademarks are the property of their respective owners.

8.3 Electrostatic Discharge Caution



This integrated circuit can be damaged by ESD. Texas Instruments recommends that all integrated circuits be handled with appropriate precautions. Failure to observe proper handling and installation procedures can cause damage.

ESD damage can range from subtle performance degradation to complete device failure. Precision integrated circuits may be more susceptible to damage because very small parametric changes could cause the device not to meet its published specifications.

8.4 Glossary

[SLYZ022](#) — *TI Glossary*.

This glossary lists and explains terms, acronyms, and definitions.

9 Mechanical, Packaging, and Orderable Information

The following pages include mechanical, packaging, and orderable information. This information is the most current data available for the designated devices. This data is subject to change without notice and revision of this document. For browser-based versions of this data sheet, refer to the left-hand navigation.

9.1 Mechanical Drawing

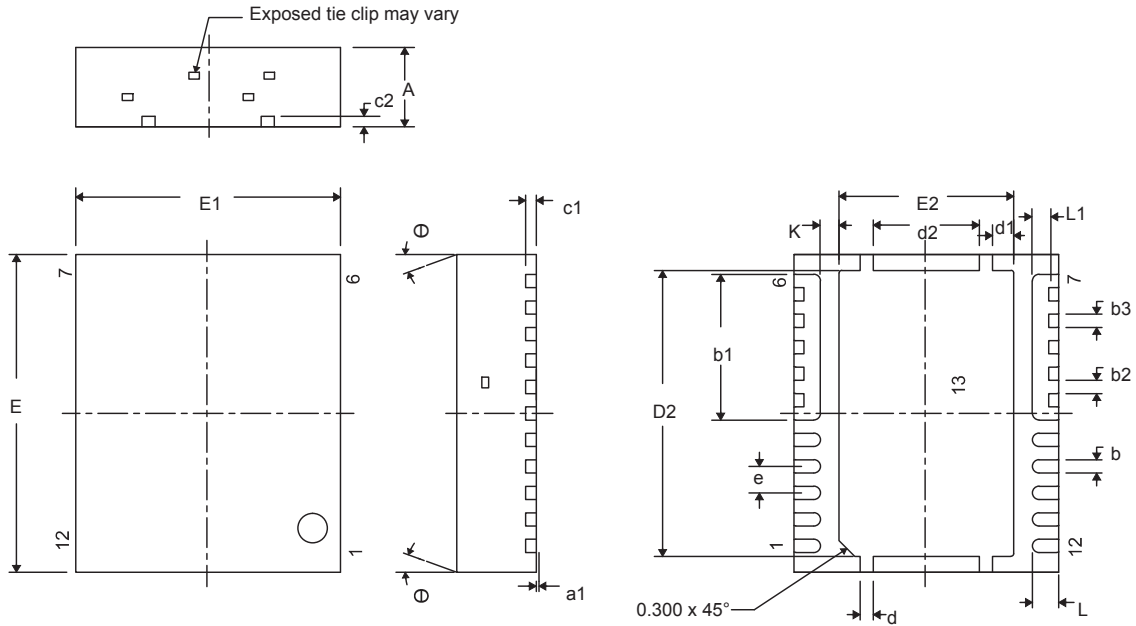

DIM	MILLIMETERS			INCHES		
	MIN	NOM	MAX	MIN	NOM	MAX
A	0.950	1.000	1.050	0.037	0.039	0.041
a1	0.000	0.000	0.050	0.000	0.000	0.002
b	0.200	0.250	0.320	0.008	0.010	0.013
b1	2.750 TYP			0.108 TYP		
b2	0.200	0.250	0.320	0.008	0.010	0.013
b3	0.250 TYP			0.010 TYP		
c1	0.150	0.200	0.250	0.006	0.008	0.010
c2	0.200	0.250	0.300	0.008	0.010	0.012
D2	5.300	5.400	5.500	0.209	0.213	0.217
d	0.200	0.250	0.300	0.008	0.010	0.012
d1	0.350	0.400	0.450	0.014	0.016	0.018
d2	1.900	2.000	2.100	0.075	0.079	0.083
E	5.900	6.000	6.100	0.232	0.236	0.240
E1	4.900	5.000	5.100	0.193	0.197	0.201
E2	3.200	3.300	3.400	0.126	0.130	0.134
e	0.500 TYP			0.020 TYP		
K	0.350 TYP			0.014 TYP		
L	0.400	0.500	0.600	0.016	0.020	0.024
L1	0.210	0.310	0.410	0.008	0.012	0.016
θ	0.00	—	—	0.00	—	—

PACKAGING INFORMATION

Orderable Device	Status (1)	Package Type	Package Drawing	Pins	Package Qty	Eco Plan (2)	Lead/Ball Finish (6)	MSL Peak Temp (3)	Op Temp (°C)	Device Marking (4/5)	Samples
CSD95372BQ5MC	ACTIVE	VSON-CLIP	DMC	12	2500	Pb-Free (RoHS Exempt)	CU SN	Level-2-260C-1 YEAR	-55 to 150	95372BMC	Samples
CSD95372BQ5MCT	ACTIVE	VSON-CLIP	DMC	12	250	Pb-Free (RoHS Exempt)	CU SN	Level-2-260C-1 YEAR	-55 to 150	95372BMC	Samples

(1) The marketing status values are defined as follows:

ACTIVE: Product device recommended for new designs.

LIFEBUY: TI has announced that the device will be discontinued, and a lifetime-buy period is in effect.

NRND: Not recommended for new designs. Device is in production to support existing customers, but TI does not recommend using this part in a new design.

PREVIEW: Device has been announced but is not in production. Samples may or may not be available.

OBsolete: TI has discontinued the production of the device.

(2) **RoHS:** TI defines "RoHS" to mean semiconductor products that are compliant with the current EU RoHS requirements for all 10 RoHS substances, including the requirement that RoHS substance do not exceed 0.1% by weight in homogeneous materials. Where designed to be soldered at high temperatures, "RoHS" products are suitable for use in specified lead-free processes. TI may reference these types of products as "Pb-Free".

RoHS Exempt: TI defines "RoHS Exempt" to mean products that contain lead but are compliant with EU RoHS pursuant to a specific EU RoHS exemption.

Green: TI defines "Green" to mean the content of Chlorine (Cl) and Bromine (Br) based flame retardants meet JS709B low halogen requirements of <=1000ppm threshold. Antimony trioxide based flame retardants must also meet the <=1000ppm threshold requirement.

(3) MSL, Peak Temp. - The Moisture Sensitivity Level rating according to the JEDEC industry standard classifications, and peak solder temperature.

(4) There may be additional marking, which relates to the logo, the lot trace code information, or the environmental category on the device.

(5) Multiple Device Markings will be inside parentheses. Only one Device Marking contained in parentheses and separated by a "~" will appear on a device. If a line is indented then it is a continuation of the previous line and the two combined represent the entire Device Marking for that device.

(6) Lead/Ball Finish - Orderable Devices may have multiple material finish options. Finish options are separated by a vertical ruled line. Lead/Ball Finish values may wrap to two lines if the finish value exceeds the maximum column width.

Important Information and Disclaimer:The information provided on this page represents TI's knowledge and belief as of the date that it is provided. TI bases its knowledge and belief on information provided by third parties, and makes no representation or warranty as to the accuracy of such information. Efforts are underway to better integrate information from third parties. TI has taken and continues to take reasonable steps to provide representative and accurate information but may not have conducted destructive testing or chemical analysis on incoming materials and chemicals. TI and TI suppliers consider certain information to be proprietary, and thus CAS numbers and other limited information may not be available for release.

In no event shall TI's liability arising out of such information exceed the total purchase price of the TI part(s) at issue in this document sold by TI to Customer on an annual basis.

TAPE AND REEL INFORMATION

QUADRANT ASSIGNMENTS FOR PIN 1 ORIENTATION IN TAPE

*All dimensions are nominal

Device	Package Type	Package Drawing	Pins	SPQ	Reel Diameter (mm)	Reel Width W1 (mm)	A0 (mm)	B0 (mm)	K0 (mm)	P1 (mm)	W (mm)	Pin1 Quadrant
CSD95372BQ5MC	VSON-CLIP	DMC	12	2500	330.0	15.4	5.3	6.3	1.2	8.0	12.0	Q1
CSD95372BQ5MCT	VSON-CLIP	DMC	12	250	330.0	15.4	5.3	6.3	1.2	8.0	12.0	Q1

TAPE AND REEL BOX DIMENSIONS

*All dimensions are nominal

Device	Package Type	Package Drawing	Pins	SPQ	Length (mm)	Width (mm)	Height (mm)
CSD95372BQ5MC	VSON-CLIP	DMC	12	2500	336.6	336.6	41.3
CSD95372BQ5MCT	VSON-CLIP	DMC	12	250	336.6	336.6	41.3

IMPORTANT NOTICE AND DISCLAIMER

TI PROVIDES TECHNICAL AND RELIABILITY DATA (INCLUDING DATASHEETS), DESIGN RESOURCES (INCLUDING REFERENCE DESIGNS), APPLICATION OR OTHER DESIGN ADVICE, WEB TOOLS, SAFETY INFORMATION, AND OTHER RESOURCES "AS IS" AND WITH ALL FAULTS, AND DISCLAIMS ALL WARRANTIES, EXPRESS AND IMPLIED, INCLUDING WITHOUT LIMITATION ANY IMPLIED WARRANTIES OF MERCHANTABILITY, FITNESS FOR A PARTICULAR PURPOSE OR NON-INFRINGEMENT OF THIRD PARTY INTELLECTUAL PROPERTY RIGHTS.

These resources are intended for skilled developers designing with TI products. You are solely responsible for (1) selecting the appropriate TI products for your application, (2) designing, validating and testing your application, and (3) ensuring your application meets applicable standards, and any other safety, security, or other requirements. These resources are subject to change without notice. TI grants you permission to use these resources only for development of an application that uses the TI products described in the resource. Other reproduction and display of these resources is prohibited. No license is granted to any other TI intellectual property right or to any third party intellectual property right. TI disclaims responsibility for, and you will fully indemnify TI and its representatives against, any claims, damages, costs, losses, and liabilities arising out of your use of these resources.

TI's products are provided subject to TI's Terms of Sale (www.ti.com/legal/termsofsale.html) or other applicable terms available either on ti.com or provided in conjunction with such TI products. TI's provision of these resources does not expand or otherwise alter TI's applicable warranties or warranty disclaimers for TI products.

Mailing Address: Texas Instruments, Post Office Box 655303, Dallas, Texas 75265
Copyright © 2019, Texas Instruments Incorporated

Looking for pricing, stock, or lifecycle information?

Click below to explore more details on WIN SOURCE:

 [View CSD95372BQ5MCT on WIN SOURCE](#)

 [Texas Instruments](#) Information

Optimize Your Supply Chain with WIN SOURCE Solutions

-  Global Sourcing Solution
-  Obsolete Management
-  Cost Control Management
-  Shortage Management
-  Alternative Solution
-  Excess Inventory Management