



**THE DATASHEET OF
ISL4243EIR-T**



ISL4241E, ISL4243E

QFN Packaged, ±15kV ESD Protected, +2.7V to +5.5V, 10Nanoamp, 250kbps, RS-232 Transmitters/Receivers

FN8037
Rev 7.00
Jun 10, 2010

Intersil's ISL4241E, ISL4243E devices are 2.7V to 5.5V powered RS-232 transmitters/receivers which meet EIA/TIA-232 and V.28/V.24 specifications, even at VCC = 3.0V. Additionally, they provide ±15kV ESD protection (IEC61000-4-2 Air Gap and Human Body Model) on transmitter outputs and receiver inputs (RS-232 pins). Targeted applications are PDAs, Palmtops, and notebook and laptop computers where the low operational, and even lower standby, power consumption is critical. Efficient on-chip charge pumps, coupled with manual and automatic power-down functions, reduce the standby supply current to a 10nA trickle. Tiny 5mmx5mm Quad Flat No-Lead (QFN) packaging and the use of small, low value capacitors ensure board space savings as well. Data rates greater than 250kbps are guaranteed at worst case load conditions.

The ISL4241E, ISL4243E's are 3 driver, 5 receiver devices that, coupled with the 5x5 QFN package, provide the industry's smallest, lowest power complete serial port suitable for PDAs, and laptop or notebook computers. The 32 Ld 5X5 QFN requires 60% less board area than a 28 Ld TSSOP, and is nearly 20% thinner. The devices also include a noninverting always-active receiver for "wake-up" capability.

The ISL4243E features an automatic power-down function that powers down the on-chip power-supply and driver circuits. This occurs when an attached peripheral device is shut off or the RS-232 cable is removed, conserving system power automatically without changes to the hardware or operating system. It powers up again when a valid RS-232 voltage is applied to any receiver input.

Table 1 summarizes the features of both the ISL4241E and ISL4243E, while Application Note AN9863 summarizes the features of each device comprising the 3V RS-232 family.

Features

- Pb-Free Available (RoHS compliant)
- Parameters Fully Specified for 10% Tolerance Supplies and Full Industrial Temp Range
- Available in Small QFN (5mmx5mm) Package which is 60% Smaller than a 28 Lead TSSOP
- ESD Protection for RS-232 I/O Pins to ±15kV (IEC61000)
- Meets EIA/TIA-232 and V.28/V.24 Specifications at 3V
- RS-232 Compatible with V_{CC} = 2.7V
- On-Chip Voltage Converters Require Only Four External 0.1µF Capacitors
- Manual and Automatic Power-down Features
- Receiver Hysteresis For Improved Noise Immunity
- Guaranteed Minimum Data Rate 250kbps
- Wide Power Supply Range Single +2.7V to +5.5V
- Low Supply Current in Power-down State 10nA

Applications

- Any Space Constrained System Requiring RS-232 Ports
 - Battery Powered, Hand-Held, and Portable Equipment
 - Laptop Computers, Notebooks
 - PDAs and Palmtops, Data Cables
 - Cellular/Mobile Phones, Digital Cameras, GPS Receivers

Related Literature

- Technical Brief TB363 "Guidelines for Handling and Processing Moisture Sensitive Surface Mount Devices
- "Technical Brief TB379 "Thermal Characterization of Packages for ICs"
- Technical Brief TB389 "PCB Land Pattern Design and Surface Mount Guidelines for QFN Packages"

TABLE 1. SUMMARY OF FEATURES

PART NUMBER	NO. OF Tx.	NO. OF Rx.	QFN PKG. AVAILABLE?	NO. OF MONITOR Rx. (R _{OUTB})	DATA RATE (kbps)	Rx. ENABLE FUNCTION?	READY OUTPUT?	MANUAL POWER-DOWN?	AUTOMATIC POWER-DOWN FUNCTION?
ISL4241E	3	5	YES	2	250	YES	NO	YES	NO
ISL4243E	3	5	YES	1	250	NO	NO	YES	YES

Ordering Information

PART NUMBER	PART MARKING	TEMP. RANGE (°C)	PACKAGE	PKG. DWG. #
ISL4241EIR	ISL 4241EIR	-40 to +85	32 Ld QFN	L32.5x5B
ISL4241EIR-T*	ISL 4241EIR	-40 to +85	32 Ld QFN Tape & Reel	L32.5x5B
ISL4241EIRZ (Note)	ISL4241 EIRZ	-40 to +85	32 Ld QFN (Pb-Free)	L32.5x5B
ISL4241EIRZ-T* (Note)	ISL4241 EIRZ	-40 to +85	32 Ld QFN Tape & Reel (Pb-Free)	L32.5x5B
ISL4243EIR	ISL 4243EIR	-40 to +85	32 Ld QFN	L32.5x5B
ISL4243EIR-T*	ISL 4243EIR	-40 to +85	32 Ld QFN Tape & Reel	L32.5x5B
ISL4243EIRZ (Note)	ISL4243 EIRZ	-40 to +85	32 Ld QFN (Pb-Free)	L32.5x5B
ISL4243EIRZ-T* (Note)	ISL4243 EIRZ	-40 to +85	32 Ld QFN Tape & Reel (Pb-Free)	L32.5x5B

*Please refer to TB347 for details on reel specifications.

NOTE: These Intersil Pb-free plastic packaged products employ special Pb-free material sets, molding compounds/die attach materials, and 100% matte tin plate plus anneal (e3 termination finish, which is RoHS compliant and compatible with both SnPb and Pb-free soldering operations). Intersil Pb-free products are MSL classified at Pb-free peak reflow temperatures that meet or exceed the Pb-free requirements of IPC/JEDEC J STD-020.

Pinouts

ISL4241E
(32 LD QFN)
TOP VIEW

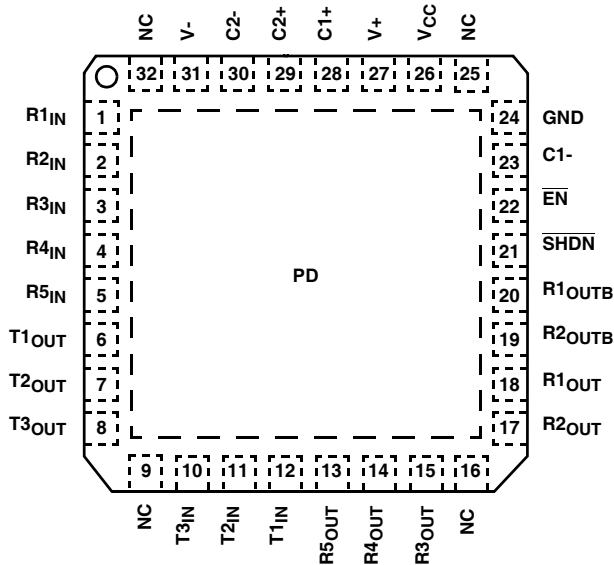

ISL4243E
(32 LD QFN)
TOP VIEW

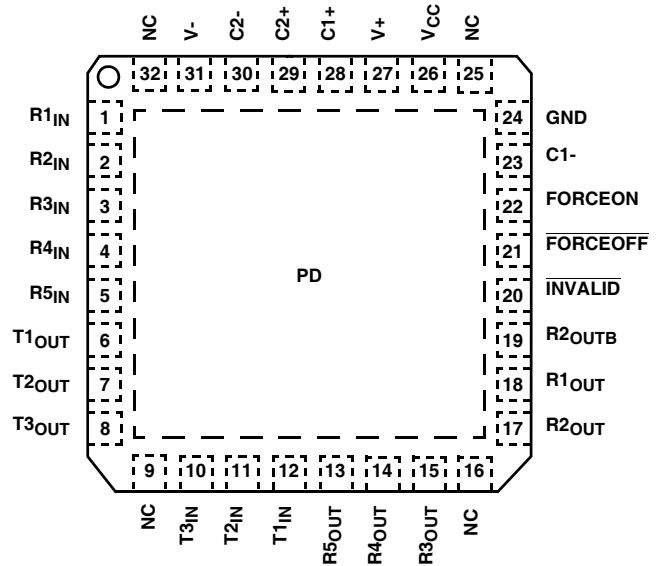

Pin Descriptions

PIN	FUNCTION
V _{CC}	System power supply input (2.7V to 5.5V).
V+	Internally generated positive transmitter supply (+5.5V).
V-	Internally generated negative transmitter supply (-5.5V).
GND	Ground connection. This is also the potential of the thermal pad (PD).
C1+	External capacitor (voltage doubler) is connected to this lead.
C1-	External capacitor (voltage doubler) is connected to this lead.
C2+	External capacitor (voltage inverter) is connected to this lead.
C2-	External capacitor (voltage inverter) is connected to this lead.
T _{IN}	TTL/CMOS compatible transmitter Inputs.
T _{OUT}	±15kV ESD Protected, RS-232 level (nominally ±5.5V) transmitter outputs.
R _{IN}	±15kV ESD Protected, RS-232 compatible receiver inputs.
R _{OUT}	TTL/CMOS level receiver outputs.
R _{OUTB}	TTL/CMOS level, noninverting, always enabled receiver outputs.
$\overline{\text{INVALID}}$	Active low output that indicates if no valid RS-232 levels are present on any receiver input.
$\overline{\text{FORCEOFF}}$	Active low to shut down transmitters and on-chip power supply. This overrides any automatic circuitry and FORCEON (see Table 2).
FORCEON	Active high input to override automatic power-down circuitry thereby keeping transmitters active. ($\overline{\text{FORCEOFF}}$ must be high).
$\overline{\text{EN}}$	Active low receiver enable control.
$\overline{\text{SHDN}}$	Active low input to shut down transmitters and on-board power supply, to place device in low power mode.
NC	No Connection
PD	Exposed Thermal Pad. Connect to GND.

Typical Operating Circuits

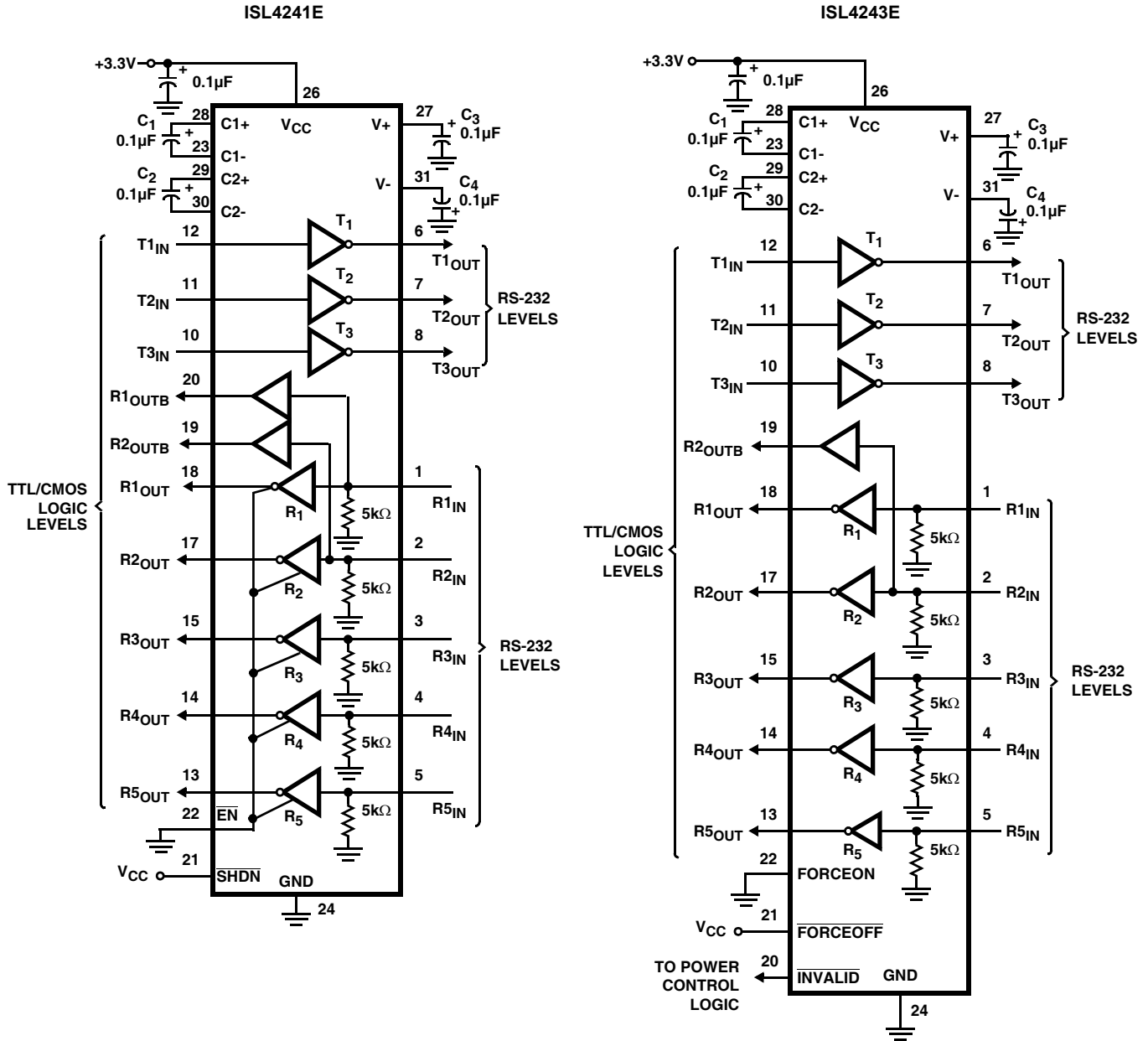

Absolute Maximum Ratings

V _{CC} to Ground	-0.3V to 6V
V ₊ to Ground	-0.3V to 7V
V ₋ to Ground	+0.3V to -7V
V ₊ to V ₋	14V
Input Voltages	
T _{IN} , FORCEOFF, FORCEON, EN, SHDN	-0.3V to 6V
R _{IN}	±25V
Output Voltages	
T _{OUT}	±13.2V
R _{OUT} , INVALID	-0.3V to V _{CC} +0.3V
Short Circuit Duration	
T _{OUT}	Continuous
ESD Rating	See "ESD PERFORMANCE" on page 7

Thermal Information

Thermal Resistance (Typical, Notes 1, 2)	θ _{JA} (°C/W)	θ _{JC} (°C/W)
32 Ld QFN Package	32	2.0
Maximum Storage Temperature Range	-65°C to +150°C	
Pb-Free Reflow Profile	see link below http://www.intersil.com/pbfree/Pb-FreeReflow.asp	

Operating Conditions

Temperature Range	ISL4241EIR, ISL4243EIR	-40°C to +85°C
-------------------	------------------------	----------------

CAUTION: Do not operate at or near the maximum ratings listed for extended periods of time. Exposure to such conditions may adversely impact product reliability and result in failures not covered by warranty.

NOTE:

1. θ_{JA} is measured in free air with the component mounted on a high effective thermal conductivity test board with "direct attach" features. See Tech Brief TB379, and Tech Brief TB389.
2. For θ_{JC}, the "case temp" location is the center of the exposed metal pad on the package underside.

Electrical Specifications Test Conditions: V_{CC} = 3V to 5.5V, C₁ to C₄ = 0.1μF; Unless Otherwise Specified.
Typicals are at T_A = +25°C

PARAMETER	TEST CONDITIONS	TEMP (°C)	MIN (Note 4)	TYP	MAX (Note 4)	UNITS
DC CHARACTERISTICS						
Operating Voltage Range		Full	2.7	-	5.5	V
Supply Current, Automatic Power-down	All R _{IN} Open, FORCEON = GND, FORCEOFF = V _{CC} (ISL4243E Only)	25	-	3	300	nA
		Full	-	50	300	nA
Supply Current, Power-down	All R _{IN} Open, FORCEOFF = SHDN = GND	25	-	3	300	nA
		Full	-	50	300	nA
Supply Current, Automatic Power-down Disabled	All Outputs Unloaded, FORCEON = FORCEOFF = SHDN = V _{CC} , V _{CC} = 3.0V	25	-	0.3	1.0	mA
		Full	-	0.3	1.5	mA
LOGIC AND TRANSMITTER INPUTS AND RECEIVER OUTPUTS						
Input Logic Threshold Low	T _{IN} , FORCEON, FORCEOFF, EN, SHDN	Full	-	-	0.8	V
Input Logic Threshold High	T _{IN} , FORCEON, FORCEOFF, EN, SHDN, V _{CC} = 3.6V	Full	2.0	-	-	V
Input Leakage Current	T _{IN} , FORCEON, FORCEOFF, EN, SHDN	Full	-	±0.01	±1.0	μA
Output Leakage Current	FORCEOFF = GND (ISL4243E) or EN = V _{CC} (ISL4241E)	Full	-	±0.05	±10	μA
Transmitter Input Hysteresis		25	-	0.5	-	V
Output Voltage Low	I _{OUT} = 1.6mA	Full	-	-	0.4	V
Output Voltage High	I _{OUT} = -1.0mA	Full	V _{CC} - 0.6	V _{CC} - 0.1	-	V
AUTOMATIC POWER-DOWN (ISL4243E Only, FORCEON = GND, FORCEOFF = V _{CC})						
Receiver Input Thresholds to Enable Transmitters	ISL4243E Powers Up (see Figure 7)	Full	-2.7	-	2.7	V
Receiver Input Thresholds to Disable Transmitters	ISL4243E Powers Down (see Figure 7)	Full	-0.3	-	0.3	V
INVALID Output Voltage Low	I _{OUT} = 1.6mA	Full	-	-	0.4	V
INVALID Output Voltage High	I _{OUT} = -1.0mA	Full	V _{CC} - 0.6	-	-	V
Receiver Threshold to Transmitters Enabled Delay (t _{WU})		Full	-	20	100	μs

Electrical Specifications Test Conditions: $V_{CC} = 3V$ to $5.5V$, C_1 to $C_4 = 0.1\mu F$; Unless Otherwise Specified.
 Typical values are at $T_A = +25^\circ C$ (Continued)

PARAMETER	TEST CONDITIONS	TEMP (°C)	MIN (Note 4)	TYP	MAX (Note 4)	UNITS	
Receiver Positive or Negative Threshold to INVALID High Delay (t_{INVH})		25	-	0.5	1	μs	
		Full	-	0.9	1.5	μs	
Receiver Positive or Negative Threshold to INVALID Low Delay (t_{INVL})		25	-	30	50	μs	
		Full	-	40	60	μs	
RECEIVER INPUTS							
Input Voltage Range		Full	-25	-	25	V	
Input Threshold Low	$V_{CC} = 3.0V$	Full	-	1.0	0.6	V	
Input Threshold High	$V_{CC} = 3.6V$	Full	2.4	1.5	-	V	
Input Hysteresis		25	-	0.5	-	V	
Input Resistance		Full	3	5	7	k Ω	
TRANSMITTER OUTPUTS							
Output Voltage Swing	All Transmitter Outputs Loaded with $3k\Omega$ to Ground	Full	± 5.0	± 5.4	-	V	
Output Resistance	$V_{CC} = V_+ = V_- = 0V$, Transmitter Output = $\pm 2V$	Full	300	10M	-	Ω	
Output Short-Circuit Current		Full	-	± 35	± 60	mA	
Output Leakage Current	$V_{OUT} = \pm 12V$, $V_{CC} = 0V$ or $3V$ to $5.5V$, Automatic Power-down or FORCEOFF = SHDN = GND	Full	-	-	± 25	μA	
TIMING CHARACTERISTICS							
Maximum Data Rate	$R_L = 3k\Omega$, $C_L = 1000pF$, One Transmitter Switching	Full	250	500	-	kbps	
Receiver Propagation Delay	Receiver Input to Receiver Output, $C_L = 150pF$	t_{PHL}	25	-	0.15	0.3	μs
			Full	-	0.2	0.35	μs
		t_{PLH}	25	-	0.3	0.5	μs
			Full	-	0.35	0.55	μs
Receiver Skew	$t_{PHL} - t_{PLH}$, $C_L = 150pF$	25	-	120	250	ns	
		Full	-	150	300	ns	
Transmitter Propagation Delay	Transmitter Input to Transmitter Output, $C_L = 1000pF$, $R_L = 3k\Omega$	t_{PHL}	25	-	0.75	1	μs
			Full	-	0.85	1.1	μs
		t_{PLH}	25	-	0.8	1	μs
			Full	-	0.9	1.1	μs
Transmitter Skew	$t_{PHL} - t_{PLH}$ (Note 3), $R_L = 3k\Omega$, $C_L = 1000pF$	25	-	50	200	ns	
		Full	-	100	250	ns	
Receiver Output Enable Time	Normal Operation, $R_L = 1k\Omega$ to $0.5V_{CC}$, $C_L = 15pF$	25	-	200	350	ns	
		Full	-	200	400	ns	
Receiver Output Disable Time	Normal Operation, $R_L = 1k\Omega$ to $0.5V_{CC}$, $C_L = 15pF$	25	-	350	500	ns	
		Full	-	400	600	ns	
Transmitter Output Enable Time	Normal Operation, $R_L = 3k\Omega$, $C_L = 1000pF$	25	-	25	40	μs	
		Full	-	30	50	μs	
Transmitter Output Disable Time	Normal Operation, $R_L = 3k\Omega$, $C_L = 1000pF$	25	-	2.5	4	μs	
		Full	-	2.7	4	μs	

Electrical Specifications Test Conditions: $V_{CC} = 3V$ to $5.5V$, C_1 to $C_4 = 0.1\mu F$; Unless Otherwise Specified.
 Typicals are at $T_A = +25^\circ C$ (Continued)

PARAMETER	TEST CONDITIONS	TEMP (°C)	MIN (Note 4)	TYP	MAX (Note 4)	UNITS	
Transition Region Slew Rate	$V_{CC} = 3V$ to $3.6V$, $R_L = 3k\Omega$ to $7k\Omega$, Measured From $3V$ to $-3V$ or $-3V$ to $3V$	$C_L = 150pF$ to $2500pF$	25	4	9	30	$V/\mu s$
			Full	4	8	30	$V/\mu s$
		$C_L = 150pF$ to $1000pF$	25	6	11	30	$V/\mu s$
			Full	6	10	30	$V/\mu s$
ESD PERFORMANCE							
RS-232 Pins (T_{OUT} , R_{IN})	Human Body Model	25	-	± 15	-	kV	
	IEC61000-4-2 Contact Discharge	25	-	± 8	-	kV	
	IEC61000-4-2 Air Gap Discharge	25	-	± 15	-	kV	
All Other Pins	Human Body Model	25	-	± 2	-	kV	

NOTE:

- Transmitter skew is measured at the transmitter zero crossing points.
- Parameters with MIN and/or MAX limits are 100% tested at $+25^\circ C$, unless otherwise specified. Temperature limits established by characterization and are not production tested.

Detailed Description

The ISL4241E and ISL4243E both operate from a single $+2.7V$ to $+5.5V$ supply, guarantee a 250kbps minimum data rate, require only four small external $0.1\mu F$ capacitors, feature low power consumption, and meet all EIA RS-232C and V.28 specifications even with $V_{CC} = 3.0V$. The circuit is divided into three sections: The charge pump, the transmitters, and the receivers.

Charge-Pump

Intersil's new ISL4241E, ISL4243E devices utilize regulated on-chip dual charge pumps as voltage doublers, and voltage inverters to generate $\pm 5.5V$ transmitter supplies from a V_{CC} supply as low as $3.0V$. This allows them to maintain RS-232 compliant output levels over the $\pm 10\%$ tolerance range of $3.3V$ powered systems. The efficient on-chip power supplies require only four small, external $0.1\mu F$ capacitors for the voltage doubler and inverter functions. The charge pumps operate discontinuously (i.e., they turn off as soon as the $V+$ and $V-$ supplies are pumped up to the nominal values), resulting in significant power savings.

Transmitters

The transmitters are proprietary, low dropout, inverting drivers that translate TTL/CMOS inputs to EIA/TIA-232 output levels. Coupled with the on-chip $\pm 5.5V$ supplies, these transmitters deliver true RS-232 levels over a wide range of single supply system voltages.

All transmitter outputs disable and assume a high impedance state when the device enters the power-down mode (see Table 2). These outputs may be driven to $\pm 12V$ when disabled.

The devices guarantee a 250kbps data rate for full load conditions ($3k\Omega$ and $1000pF$), $V_{CC} \geq 3.0V$, with one

transmitter operating at full speed. Under more typical conditions of $V_{CC} \geq 3.3V$, $R_L = 3k\Omega$, and $C_L = 250pF$, one transmitter easily operates at 900kbps.

Transmitter inputs float if left unconnected, and may cause I_{CC} increases. Connect unused inputs to GND for the best performance.

Receivers

All the ISL4241E, ISL4243E's devices contain standard inverting receivers that are three-state via the \overline{EN} or FORCEOFF control lines. Additionally, the ISL4241E, ISL4243E's products include noninverting (monitor) receivers (denoted by the R_{OUTB} label) that are always active, regardless of the state of any control lines. All the receivers convert RS-232 signals to CMOS output levels and accept inputs up to $\pm 25V$ while presenting the required $3k\Omega$ to $7k\Omega$ input impedance (see Figure 1) even if the power is off ($V_{CC} = 0V$). The receivers' Schmitt trigger input stage uses hysteresis to increase noise immunity and decrease errors due to slow input signal transitions.

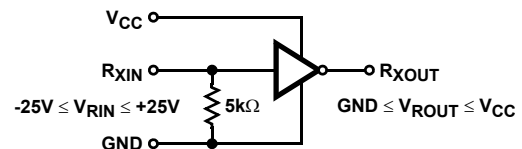

FIGURE 1. INVERTING RECEIVER CONNECTIONS

The ISL4241E inverting receivers disable only when \overline{EN} is driven high. ISL4243E receivers disable during forced (manual) power-down, but not during automatic power-down (see Table 2).

TABLE 2. POWER-DOWN AND ENABLE LOGIC TRUTH TABLE

RS-232 SIGNAL PRESENT AT RECEIVER INPUT?	$\overline{\text{SHDN}}$ OR FORCEOFF INPUT	FORCEON INPUT	$\overline{\text{EN}}$ INPUT	TRANSMITTER OUTPUTS	RECEIVER OUTPUTS	R _{OUTB} OUTPUTS	$\overline{\text{INVALID}}$ OUTPUT	MODE OF OPERATION
ISL4241E								
N.A.	L	N/A	L	High-Z	Active	Active	N/A	Manual Power-down
N.A.	L	N/A	H	High-Z	High-Z	Active	N/A	Manual Power-down w/Receiver Disabled
N.A.	H	N/A	L	Active	Active	Active	N/A	Normal Operation
N.A.	H	N/A	H	Active	High-Z	Active	N/A	Normal Operation w/Receiver Disabled
ISL4243E								
NO	H	H	N/A	Active	Active	Active	L	Normal Operation (Auto Power-down Disabled)
YES	H	L	N/A	Active	Active	Active	H	Normal Operation (Auto Power-down Enabled)
NO	H	L	N/A	High-Z	Active	Active	L	Power-down Due to Auto Power-down Logic
YES	L	X	N/A	High-Z	High-Z	Active	H	Manual Power-down
NO	L	X	N/A	High-Z	High-Z	Active	L	Manual Power-down

ISL4241E and ISL4243E monitor receivers remain active even during manual power-down, making them extremely useful for Ring Indicator monitoring. Standard receivers driving powered down peripherals must be disabled to prevent current flow through the peripheral's protection diodes (see Figures 2 and 3). This renders them useless for wake-up functions, but the corresponding monitor receiver can be dedicated to this task as shown in Figure 3.

Low Power Operation

These 3V devices require a nominal supply current of 0.3mA, even at $V_{CC} = 5.5V$, during normal operation (not in power-down mode). This is considerably less than the 5mA to 11mA current required by comparable 5V RS-232 devices, allowing users to reduce system power simply by switching to this new family.

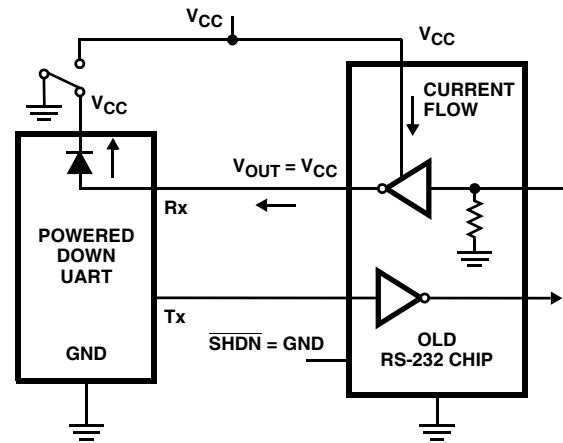

FIGURE 2. POWER DRAIN THROUGH POWERED DOWN PERIPHERAL

Power-down Functionality

The already low current requirement drops significantly when the device enters power-down mode. In power-down, supply current drops to 10nA, because the on-chip charge pump turns off ($V+$ collapses to V_{CC} , $V-$ collapses to GND), and the transmitter outputs three-state. Inverting receiver outputs disable only in manual power-down; refer to Table 2 for details. This micro-power mode makes the ISL4241E and ISL4243E ideal for battery powered and portable applications.

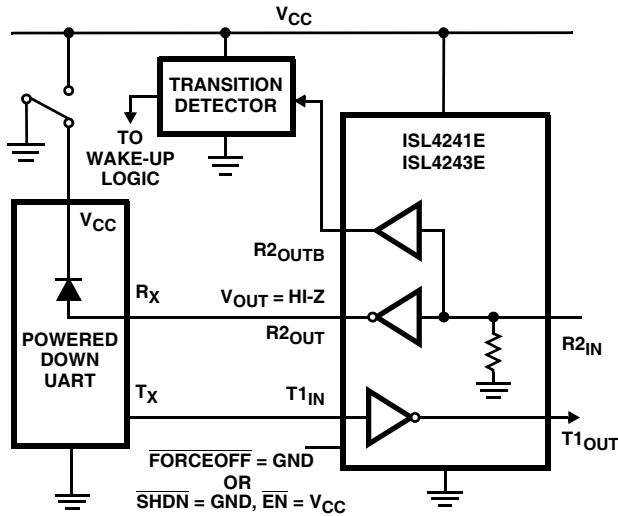

FIGURE 3. DISABLED RECEIVERS PREVENT POWER DRAIN

Software Controlled (Manual) Power-down

Most devices in the ISL4241E, ISL4243E family provide pins that allow the user to force the IC into the low power, standby state.

On the ISL4241E, the power-down control is via a simple shutdown (SHDN) pin. Driving this pin high enables normal operation, while driving it low forces the IC into its power-down state. Connect SHDN to VCC if the power-down function isn't needed. Note that all the receiver outputs remain enabled during shutdown (see Table 2). For the lowest power consumption during power-down, the receivers should also be disabled by driving the EN input high (see next section, and Figures 2 and 3).

The ISL4243E utilize a two pin approach where the FORCEON and FORCEOFF inputs determine the IC's mode. For always enabled operation, FORCEON and FORCEOFF are both strapped high. To switch between active and power-down modes, under logic or software control, only the FORCEOFF input need be driven. The FORCEON state isn't critical, as FORCEOFF dominates over FORCEON. Nevertheless, if strictly manual control over power-down is desired, the user must strap FORCEON high to disable the automatic power-down circuitry. The ISL4243E inverting (standard) receiver outputs also disable when the device is in manual power-down, thereby eliminating the possible current path through a shutdown peripheral's input protection diode (see Figures 2 and 3).

Connecting FORCEOFF and FORCEON together disables the automatic power-down feature, enabling them to function as a manual SHUTDOWN input (see Figure 4).

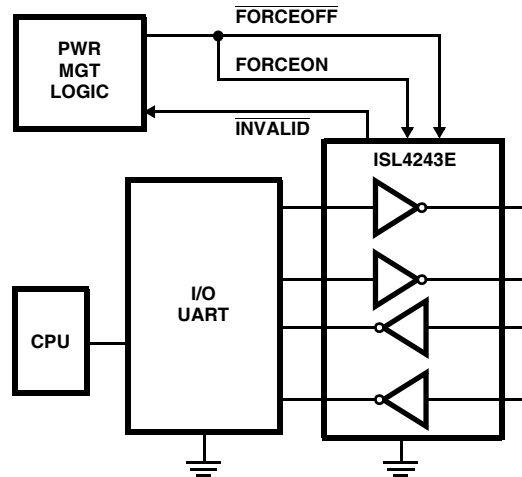

FIGURE 4. CONNECTIONS FOR MANUAL POWER-DOWN WHEN NO VALID RECEIVER SIGNALS ARE PRESENT

With any of the previous mentioned control schemes, the time required to exit power-down, and resume transmission is only 100µs. A mouse, or other application, may need more time to wake up from shutdown. If automatic power-down is being utilized, the RS-232 device will reenter power-down if valid receiver levels aren't reestablished within 30µs of the ISL4243E powering up. Figure 5 illustrates a circuit that keeps the ISL4243E from initiating automatic power-down for 100ms after powering up. This gives the slow-to-wake peripheral circuit time to reestablish valid RS-232 output levels.

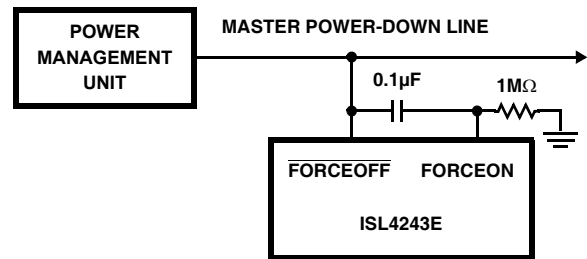

FIGURE 5. CIRCUIT TO PREVENT AUTO POWER-DOWN FOR 100ms AFTER FORCED POWERUP

INVALID Output (ISL4243E Only)

The INVALID output always indicates whether or not a valid RS-232 signal (see Figure 6) is present at any of the receiver inputs (see Table 2), giving the user an easy way to determine when the interface block should power down. Invalid receiver levels occur whenever the driving peripheral's outputs are shut off (powered down) or when the RS-232 interface cable is disconnected. In the case of a disconnected interface cable where all the receiver inputs are floating (but pulled to GND by the internal receiver pull down resistors), the INVALID logic detects the invalid levels and drives the output low. The power management logic

then uses this indicator to power down the interface block. Reconnecting the cable restores valid levels at the receiver inputs, $\overline{\text{INVALID}}$ switches high, and the power management logic wakes up the interface block. $\overline{\text{INVALID}}$ can also be used to indicate the DTR or RING INDICATOR signal, as long as the other receiver inputs are floating, or driven to GND (as in the case of a powered down driver).

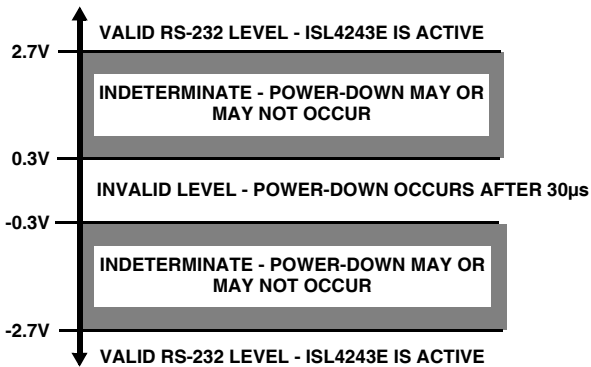

FIGURE 6. DEFINITION OF VALID RS-232 RECEIVER LEVELS

$\overline{\text{INVALID}}$ switches low after invalid levels have persisted on all of the receiver inputs for more than 30μs (see Figure 7). $\overline{\text{INVALID}}$ switches back high 1μs after detecting a valid RS-232 level on a receiver input. $\overline{\text{INVALID}}$ operates in all modes (forced or automatic power-down, or forced on), so it is also useful for systems employing manual power-down circuitry. When automatic power-down is utilized, $\overline{\text{INVALID}} = 0$ indicates that the ISL4243E is in power-down mode.

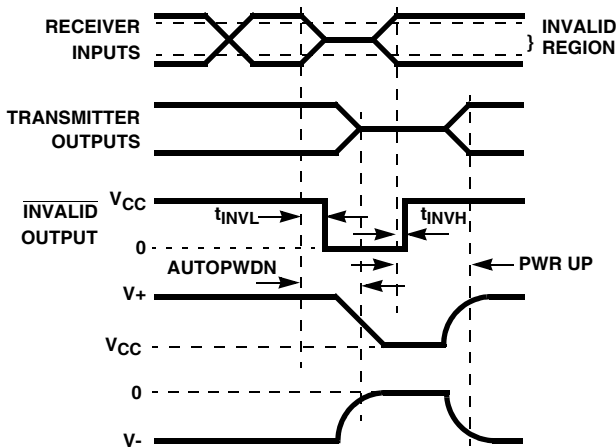

FIGURE 7. AUTOMATIC POWER-DOWN AND INVALID TIMING DIAGRAMS

Automatic Power-down (ISL4243E Only)

Even greater power savings is available by using the ISL4243E which features an *automatic* power-down function. When no valid RS-232 voltages (see Figure 5) are sensed on any receiver input for 30μs, the charge pump and transmitters power-down, thereby reducing supply current to 10nA. Invalid receiver levels occur whenever the driving

peripheral’s outputs are shut off (powered down) or when the RS-232 interface cable is disconnected. The ISL4243E powers back up whenever it detects a valid RS-232 voltage level on any receiver input. This automatic power-down feature provides additional system power savings without changes to the existing operating system.

Automatic power-down operates when the FORCEON input is low, and the $\overline{\text{FORCEOFF}}$ input is high. Tying FORCEON high disables automatic power-down, but manual power-down is always available via the overriding $\overline{\text{FORCEOFF}}$ input. Table 2 summarizes the automatic power-down functionality.

The time to recover from automatic power-down mode is typically 100μs.

Capacitor Selection

The charge pumps require 0.1μF, or greater, capacitors for proper operation. Increasing the capacitor values (by a factor of 2) reduces ripple on the transmitter outputs and slightly reduces power consumption.

When using minimum required capacitor values, make sure that capacitor values do not degrade excessively with temperature. If in doubt, use capacitors with a larger nominal value. The capacitor’s equivalent series resistance (ESR) usually rises at low temperatures and it influences the amount of ripple on V_{+} and V_{-} .

Power Supply Decoupling

In most circumstances a 0.1μF bypass capacitor is adequate. In applications that are particularly sensitive to power supply noise, decouple V_{CC} to ground with a capacitor of the same value as the charge-pump capacitor C_1 . Connect the bypass capacitor as close as possible to the IC.

Transmitter Outputs when Exiting Power-down

Figure 8 shows the response of two transmitter outputs when exiting power-down mode. As they activate, the two transmitter outputs properly go to opposite RS-232 levels, with no glitching, ringing, nor undesirable transients. Each transmitter is loaded with 3kΩ in parallel with 2500pF. Note that the transmitters enable only when the magnitude of the supplies exceed approximately 3V.

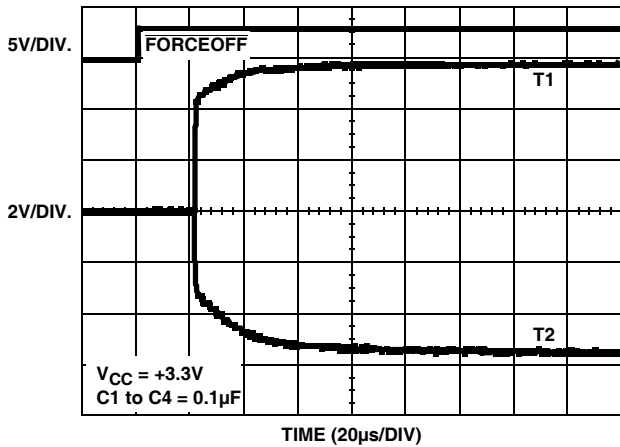

FIGURE 8. TRANSMITTER OUTPUTS WHEN EXITING POWER-DOWN

Operation Down to 2.7V

The ISL4241E, ISL4243E transmitter outputs meet RS-562 levels ($\pm 3.7V$), at the full data rate, with V_{CC} as low as 2.7V. RS-562 levels typically ensure inter operability with RS-232 devices.

High Data Rates

The ISL4241E, ISL4243E maintain the RS-232 $\pm 5V$ minimum transmitter output voltages even at high data rates. Figure 9 details a transmitter loopback test circuit, and Figure 10 illustrates the loopback test result at 120kbps. For this test, all transmitters were simultaneously driving RS-232 loads in parallel with 1000pF, at 120kbps. Figure 11 shows the loopback results for a single transmitter driving 1000pF and an RS-232 load at 250kbps. The static transmitters were also loaded with an RS-232 receiver.

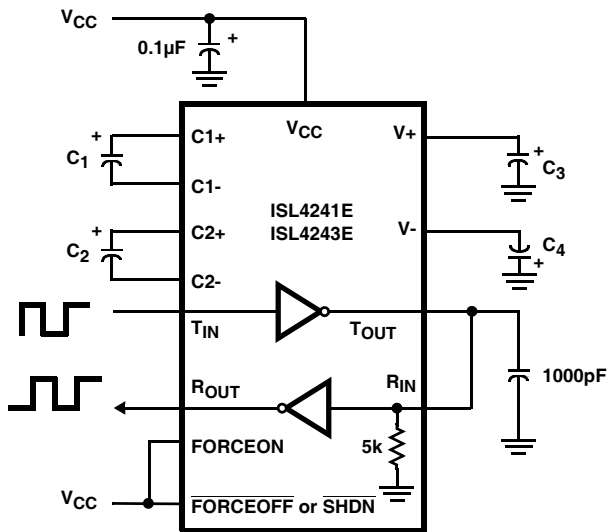

FIGURE 9. TRANSMITTER LOOPBACK TEST CIRCUIT

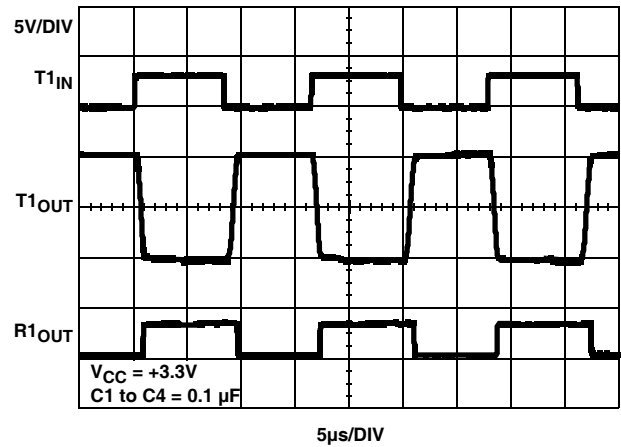

FIGURE 10. LOOPBACK TEST AT 120kbps

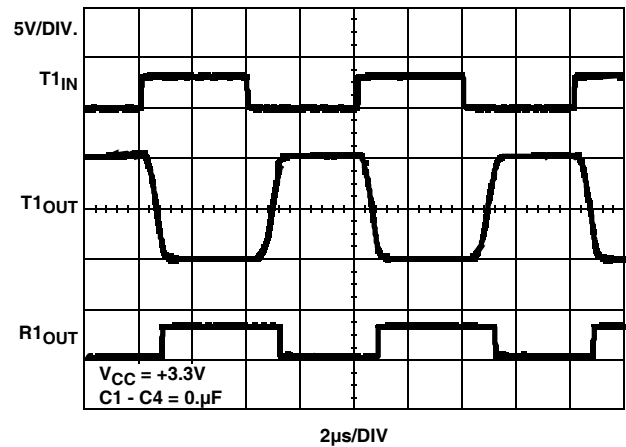

FIGURE 11. LOOPBACK TEST AT 250kbps

Interconnection with 3V and 5V Logic

The ISL4241E, ISL4243E directly interface with 5V CMOS and TTL logic families. Nevertheless, with the ISL4241E, ISL4243E at 3.3V, and the logic supply at 5V, AC, HC, and CD4000 outputs can drive ISL4241E, ISL4243E inputs, but ISL4241E, ISL4243E outputs do not reach the minimum V_{IH} for these logic families. See Table 3 for more information.

TABLE 3. LOGIC FAMILY COMPATIBILITY WITH VARIOUS SUPPLY VOLTAGES

SYSTEM POWER-SUPPLY VOLTAGE (V)	V _{CC} SUPPLY VOLTAGE (V)	COMPATIBILITY
3.3	3.3	Compatible with all CMOS families.
5	5	Compatible with all TTL and CMOS logic families.

TABLE 3. LOGIC FAMILY COMPATIBILITY WITH VARIOUS SUPPLY VOLTAGES (Continued)

SYSTEM POWER-SUPPLY VOLTAGE (V)	V _{CC} SUPPLY VOLTAGE (V)	COMPATIBILITY
5	3.3	Compatible with ACT and HCT CMOS, and with TTL. ISL4241E, ISL4243E outputs are incompatible with AC, HC, and CD4000 CMOS inputs.

±15kV ESD Protection

All pins on ISL4241E, ISL4243E devices include ESD protection structures, but the RS-232 pins (transmitter outputs and receiver inputs) incorporate advanced structures which allow them to survive ESD events up to ±15kV. The RS-232 pins are particularly vulnerable to ESD damage because they typically connect to an exposed port on the exterior of the finished product. Simply touching the port pins, or connecting a cable, can cause an ESD event that might destroy unprotected ICs. These new ESD structures protect the device whether or not it is powered up, protect without allowing any latchup mechanism to activate, and don't interfere with RS-232 signals as large as ±25V.

Human Body Model (HBM) Testing

As the name implies, this test method emulates the ESD event delivered to an IC during human handling. The tester delivers the charge through a 1.5kΩ current limiting resistor, making the test less severe than the IEC61000 test which utilizes a 330Ω limiting resistor. The HBM method determines an ICs ability to withstand the ESD transients typically present during handling and manufacturing. Due to the random nature of these events, each pin is tested with

Typical Performance Curves V_{CC} = 3.3V, T_A = +25°C

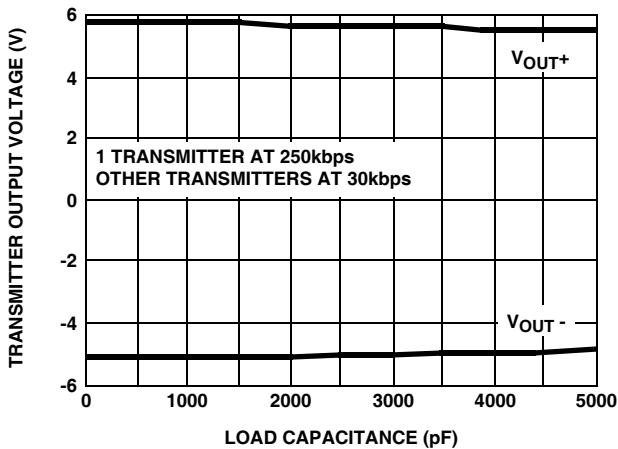

FIGURE 12. TRANSMITTER OUTPUT VOLTAGE vs LOAD CAPACITANCE

respect to all other pins. The RS-232 pins on “E” family devices can withstand HBM ESD events to ±15kV.

IEC61000-4-2 Testing

The IEC61000 test method applies to finished equipment, rather than to an individual IC. Therefore, the pins most likely to suffer an ESD event are those that are exposed to the outside world (the RS-232 pins in this case), and the IC is tested in its typical application configuration (power applied) rather than testing each pin-to-pin combination. The lower current limiting resistor coupled with the larger charge storage capacitor yields a test that is much more severe than the HBM test. The extra ESD protection built into this device’s RS-232 pins allows the design of equipment meeting level 4 criteria without the need for additional board level protection on the RS-232 port.

AIR-GAP DISCHARGE TEST METHOD

For this test method, a charged probe tip moves toward the IC pin until the voltage arcs to it. The current waveform delivered to the IC pin depends on approach speed, humidity, temperature, etc., so it is difficult to obtain repeatable results. The “E” device RS-232 pins withstand ±15kV air-gap discharges.

CONTACT DISCHARGE TEST METHOD

During the contact discharge test, the probe contacts the tested pin before the probe tip is energized, thereby eliminating the variables associated with the air-gap discharge. The result is a more repeatable and predictable test, but equipment limits prevent testing devices at voltages higher than ±8kV. All “E” family devices survive ±8kV contact discharges on the RS-232 pins.

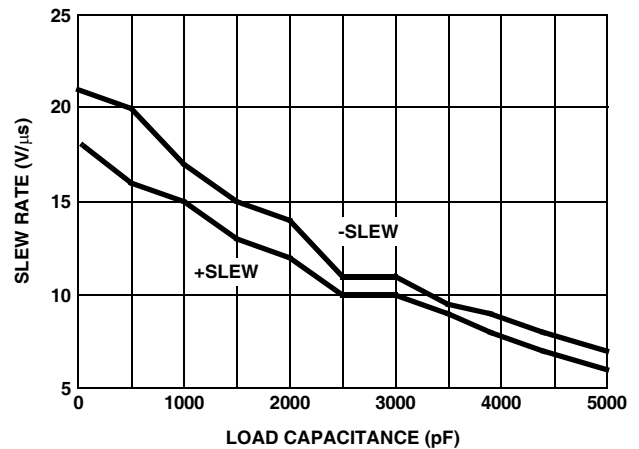

FIGURE 13. SLEW RATE vs LOAD CAPACITANCE

Typical Performance Curves $V_{CC} = 3.3V, T_A = +25^{\circ}C$ (Continued)

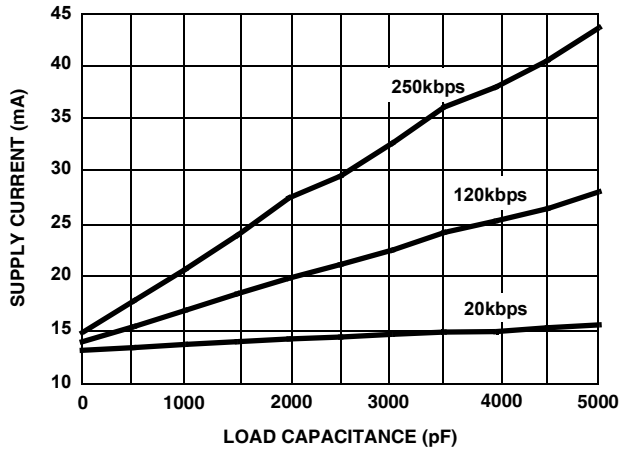

FIGURE 14. SUPPLY CURRENT vs LOAD CAPACITANCE WHEN TRANSMITTING DATA

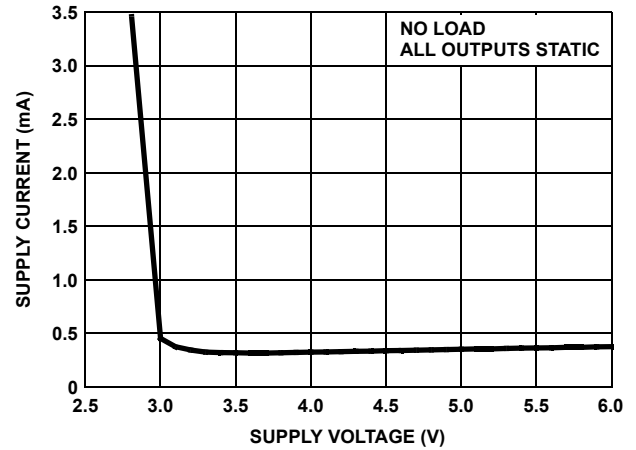

FIGURE 15. SUPPLY CURRENT vs SUPPLY VOLTAGE

Die Characteristics

SUBSTRATE AND QFN THERMAL PAD POTENTIAL (POWERED UP):

GND

TRANSISTOR COUNT:

ISL4241E, ISL4243E: 464

PROCESS:

Si Gate BiCMOS

© Copyright Intersil Americas LLC 2002-2010. All Rights Reserved.
 All trademarks and registered trademarks are the property of their respective owners.

For additional products, see www.intersil.com/en/products.html

Intersil products are manufactured, assembled and tested utilizing ISO9001 quality systems as noted in the quality certifications found at www.intersil.com/en/support/qualandreliability.html

Intersil products are sold by description only. Intersil may modify the circuit design and/or specifications of products at any time without notice, provided that such modification does not, in Intersil's sole judgment, affect the form, fit or function of the product. Accordingly, the reader is cautioned to verify that datasheets are current before placing orders. Information furnished by Intersil is believed to be accurate and reliable. However, no responsibility is assumed by Intersil or its subsidiaries for its use; nor for any infringements of patents or other rights of third parties which may result from its use. No license is granted by implication or otherwise under any patent or patent rights of Intersil or its subsidiaries.

For information regarding Intersil Corporation and its products, see www.intersil.com

Package Outline Drawing

L32.5x5B

32 LEAD QUAD FLAT NO-LEAD PLASTIC PACKAGE

Rev 2, 11/07

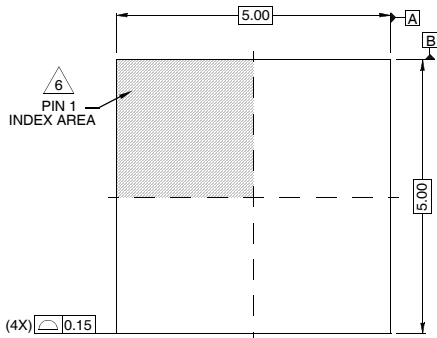

TOP VIEW

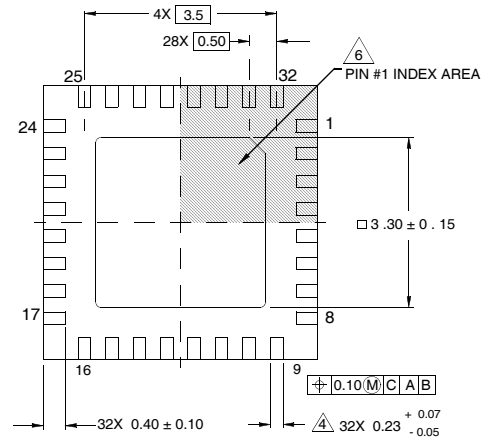

BOTTOM VIEW

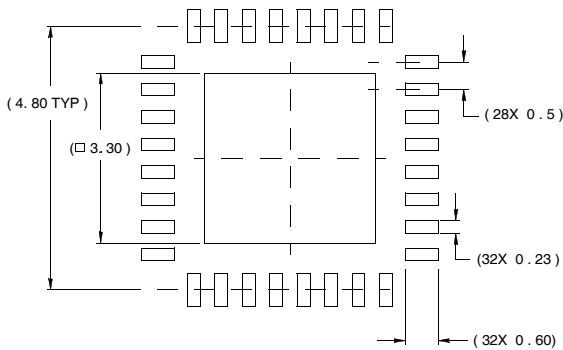

TYPICAL RECOMMENDED LAND PATTERN

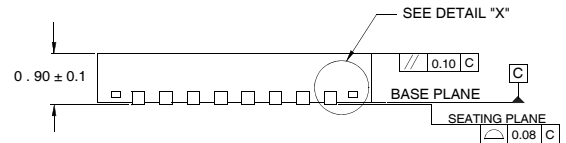

SIDE VIEW

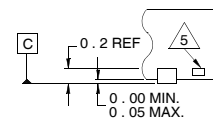

DETAIL "X"

NOTES:

1. Dimensions are in millimeters.
Dimensions in () for Reference Only.
2. Dimensioning and tolerancing conform to AMSE Y14.5m-1994.
3. Unless otherwise specified, tolerance : Decimal ± 0.05
4. Dimension b applies to the metallized terminal and is measured between 0.15mm and 0.30mm from the terminal tip.
5. Tiebar shown (if present) is a non-functional feature.
6. The configuration of the pin #1 identifier is optional, but must be located within the zone indicated. The pin #1 identifier may be either a mold or mark feature.

Looking for pricing, stock, or lifecycle information?

Click below to explore more details on WIN SOURCE:

 [View ISL4243EIR-T on WIN SOURCE](#)

 [Intersil Information](#)

Optimize Your Supply Chain with WIN SOURCE Solutions

-  Global Sourcing Solution
-  Obsolete Management
-  Cost Control Management
-  Shortage Management
-  Alternative Solution
-  Excess Inventory Management