



**THE DATASHEET OF
MP3309GQG-Z**



DESCRIPTION

The MP3309 is a WLED step-up converter for 2.7V-to-5.5V input that uses peak-current mode to regulate the LED current sensed through an external, low-side resistor. The 200mV feedback voltage and synchronous rectification reduces power loss and reduces PCB space requirements. For non-synchronous mode, setting an internal register can disable the rectifier MOSFET to save driver losses.

The MP3309 features a programmable switching frequency to optimize efficiency. It supports both analog and PWM dimming.

In addition, the MP3309 has LED open protection, cycle-by-cycle current limit protection, Under voltage protection and thermal shutdown protection -. The I²C interface can set the protection indication bits and over-voltage protection point.

FEATURES

- 2.7V-to-5.5V Input Voltage
- Analog and PWM Dimming
- Selectable Synchronous or Non-synchronous Mode
- 400kHz I²C-Compatible Interface
- Digitally-Set LED Current
- Programmable Switching Frequency
- Programmable Over Voltage Protection Point
- Low 200mV Feedback Voltage with $\pm 1\%$
- Software- or Hardware-Enable Function
- Internal Soft Start
- UVLO, Thermal Shutdown, OCP
- Available in a 1.4mm \times 1.8mm QFN-10 package

MP3309—Default Analog Dimming (PWMH) by external PWM signal input

MP3309C—Default I²C Interface

APPLICATIONS

- Feature Phones and Smart Phones
- Tablets
- <10inch Video Displays

All MPS parts are lead-free and adhere to the RoHS directive. For MPS green status, please visit MPS website under Products, Quality Assurance page. "MPS" and "The Future of Analog IC Technology" are Registered Trademarks of Monolithic Power Systems, Inc.

TYPICAL APPLICATION

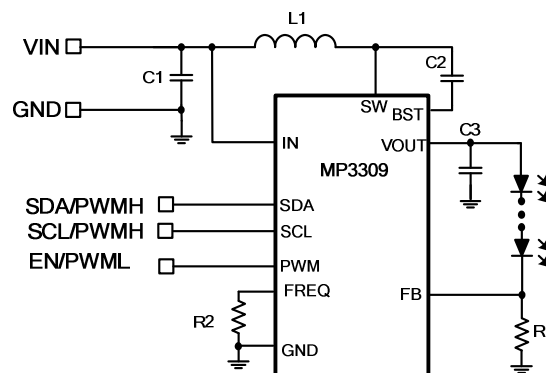

Typical Application Circuit

ORDERING INFORMATION

Part Number	Package	Top Marking
MP3309GQG*	QFN-10 (1.4mm×1.8mm)	BM
MP3309CGQG	QFN-10 (1.4mm×1.8mm)	CJ

* For Tape & Reel, add suffix -Z (e.g. MP3309GQG-Z);
 ** For Tape & Reel, add suffix -Z (e.g. MP3309CGQG-Z);

PACKAGE REFERENCE

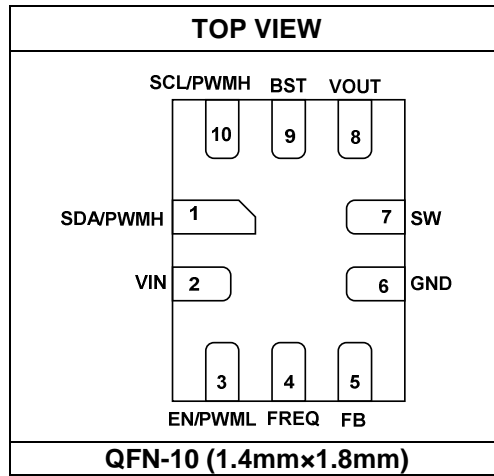

ABSOLUTE MAXIMUM RATINGS ⁽¹⁾

V_{IN}	-0.3V to +6V
V_{SW} , V_{OUT}	-1V to +40V
V_{BST}	-0.3V to V_{SW} +6V
All Other Pins.....	-0.3V to +6V
Junction Temperature.....	150°C
Lead Temperature	260°C
Continuous Power Dissipation ($T_A = 25^\circ\text{C}$) ⁽²⁾	0.892W

Recommended Operating Conditions ⁽³⁾

Supply Voltage V_{IN}	2.7V to 5.5V
Operating Junction Temp. (T_J).	-40°C to +125°C

Thermal Resistance ⁽⁴⁾	θ_{JA}	θ_{JC}
QFN-10 (1.4mm×1.8mm)	140.....	30 °C/W

Notes:

- Exceeding these ratings may damage the device.
- The maximum allowable power dissipation is a function of the maximum junction temperature T_J (MAX), the junction-to-ambient thermal resistance θ_{JA} , and the ambient temperature T_A . The maximum allowable continuous power dissipation at any ambient temperature is calculated by P_D (MAX) = $(T_J$ (MAX) - T_A) / θ_{JA} . Exceeding the maximum allowable power dissipation will cause excessive die temperature, and the regulator will go into thermal shutdown. Internal thermal shutdown circuitry protects the device from permanent damage.
- The device is not guaranteed to function outside of its operating conditions.
- Measured on JESD51-7, 4-layer PCB.

ELECTRICAL CHARACTERISTICS

 $V_{IN} = 3.6V$, $V_{EN} = V_{IN}$, $T_A = 25^\circ C$, unless otherwise noted.

Parameters	Symbol	Condition	Min	Typ	Max	Units
STEP-UP CONVERTER						
Operating Input Voltage	V_{IN}		2.7		5.5	V
Supply Current (Quiescent)	I_Q	$V_{IN}=3.6V$, $V_{EN}=V_{IN}$, no load with switching		420		μA
Supply Current (Shutdown)	I_{ST}	$V_{EN}=0V$, $V_{IN}=3.6V$			1	μA
		EN Bit=0, $V_{IN}=3.6V$		68		μA
Input UVLO Threshold	V_{IN_UVLO}	Rising Edge		2.5		V
Input UVLO Hysteresis				200		mV
EN High Voltage	V_{EN_HIGH}	V_{EN} Rising	1.2			V
EN Low Voltage	V_{EN_LOW}	V_{EN} Falling			0.4	V
Switching Frequency	f_{SW}	$R_{OSC} = 200k\Omega$	540	640	740	kHz
Maximum Duty Cycle	D_{MAX}	Sync Mode, 600kHz	89	93		%
		Non-sync Mode, 600kHz	90	95		
Feedback Regulation Voltage	V_{REF}		198	200	202	mV
VREF Ramp-Up Time	t_{STEP}			320		μs
POWER SWITCH						
Main Switch On-Resistance	R_{DSON_M}	$V_{IN}=3.6V$		0.3	0.5	Ω
Sync Switch On-Resistance	R_{DSON_S}	$V_{IN}=3.6V$		0.5	0.8	Ω
CURRENT DIMMING						
PWMH Input Low Threshold	V_{PWM_LO}	V_{PWM} Falling	0.4			V
PWMH Input High Threshold	V_{PWM_HI}	V_{PWM} Rising			1.2	V
PWML Shutdown Time	t_{SD}	EN/PWML High to Low		20		ms
PROTECTION						
OVP Voltage	V_{OVP}	OVP0=0,OVP1=1(Default)	33.5	35.5	37.5	V
		Hysteresis		2.5		
		OVP0=1,OVP1=0	22.5	24	25.5	V
		Hysteresis		2		
		OVP0=0,OVP1=0	12.5	13.5	14.5	V
		Hysteresis		1		
Cycle-Cycle Current Limit	I_{LIM}	OVP0=1,OVP1=0		1.5		A
Startup Current Limit	I_{LIM_START}	Max Duty Cycle		0.8		A
Time Step for Half Current Limit	T_{LIM_HALF}			5		ms

ELECTRICAL CHARACTERISTICS (continued)

$V_{IN} = 3.6V$, $V_{EN} = V_{IN}$, $T_A = 25^\circ C$, unless otherwise noted.

Parameters	Symbol	Condition	Min	Typ	Max	Units
OVP UVLO Threshold	V_{OVP_UV}			1.24		V
Thermal Shutdown Threshold	t_{ST}			150		°C
Thermal Shutdown Hysteresis				25		°C
I²C Interface Specifications						
Input Logic Low	V_{IL}		0		0.4	V
Input Logic High	V_{IH}		1.3V			V
Output Logic Low	V_{OL}	ILOAD=3mA			0.4	V
SCL Clock Frequency	f_{SCL}				400	KHz
SCL High Time	t_{HIGH}		0.6			µs
SCL Low Time	t_{LOW}		1.3			µs
Data Setup Time	$t_{SU,DAT}$		100			ns
Data Hold Time	$t_{HD,DAT}$		0		0.9	µs
Setup Time for Repeated Start	$t_{SU,STA}$		0.6			µs
Hold Time for Start	$t_{HD,STA}$		0.6			µs
Bus Free Time between a Start and a Stop Condition	t_{BUF}		1.3			µs
Setup Time for Stop Condition	$t_{SU,STO}$		0.6			µs
Rise Time of SCL and SDA	t_R		$20+0.1 \times C_B$		120	ns
Fall Time of SCL and SDA	t_F		$20+0.1 \times C_B$		120	ns
Pulse Width of Suppressed Spike	t_{SP}		0		50	ns
Capacitance Bus for Each Bus Line	C_B				400	pF

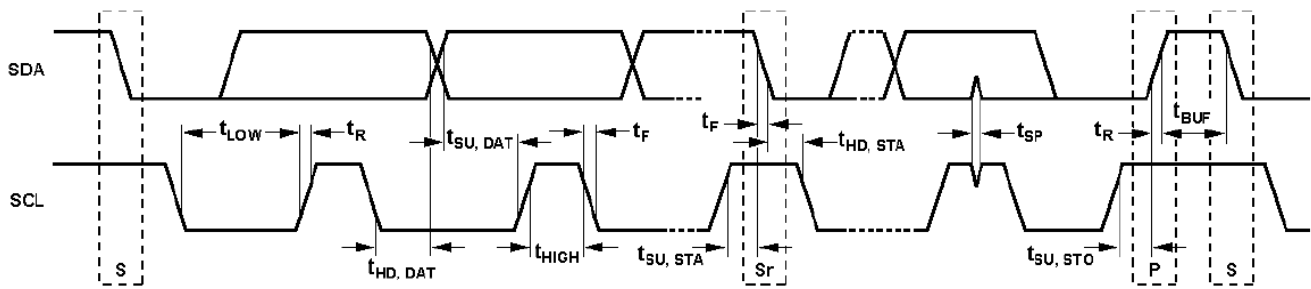

S = START CONDITION
 Sr = REPEATED START CONDITION
 P = STOP CONDITION

I²C Compatible Interface Timing Diagram

TYPICAL PERFORMANCE CHARACTERISTICS

$V_{IN} = 3.6V$, 8 LEDs, $I_{LED} = 20mA$, $L = 10\mu H$, $T_A = 25^\circ C$, unless otherwise noted.

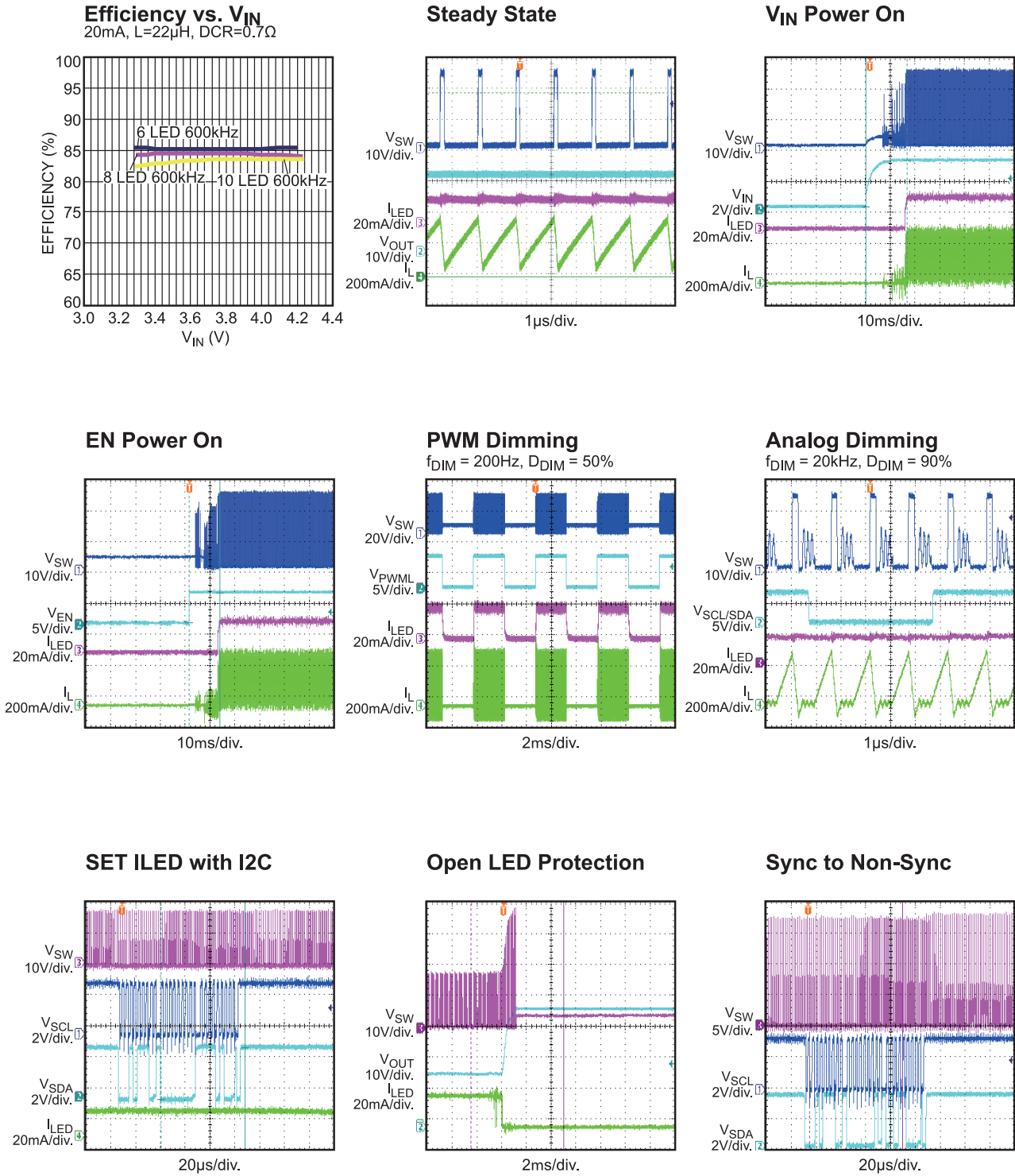

PIN FUNCTIONS

Pin #	Name	Description
1	SDA	I ² C Data Input. For MP3309, connect the SCL(PWMH) and SDA(PWMH) pins together as one PWM signal input for analog dimming. >20kHz PWM signal is recommended input for analog dimming.
2	VIN	Input Supply Pin. Provides power for internal power and logic circuits. Must be locally bypassed.
3	EN/PWML	PWM Brightness Control/Enable. Apply a PWM signal for PWM dimming. The PWM duty is proportional to the LED current dimming—a lower dimming duty results in a smaller dimming current. For most applications, use a frequency range of 200Hz to 2kHz. A low-level signal longer than 20ms will shutdown the IC.
4	RFEQ	Switching Frequency Set. Connect a resistor between this pin and GND to program the converter switching frequency. Do not leave this pin floating.
5	FB	LED Current Feedback. Regulates the voltage across the current sense resistor between FB and GND to 200mV.
6	GND	Ground.
7	SW	Power Switch Node. Drain of the internal low-side MOSFET. Connect the power inductor between SW and VIN pin. For non-synchronous mode, connect a Schottky diode between this pin and VOUT.
8	VOUT	Output Voltage. Internally connected to the source of the synchronous MOSFET. For non-synchronous mode, connect a Schottky diode between SW pin and this pin. .
9	BST	Booststrap. Connect a capacitor between SW and BST pin to provide the synchronous MOSFET gate driver.
10	SCL	I ² C Interface Clock Signal. For MP3309 connect the SCL and SDA pins together as PWM input for analog LED dimming. >20kHz PWM signal is recommended.

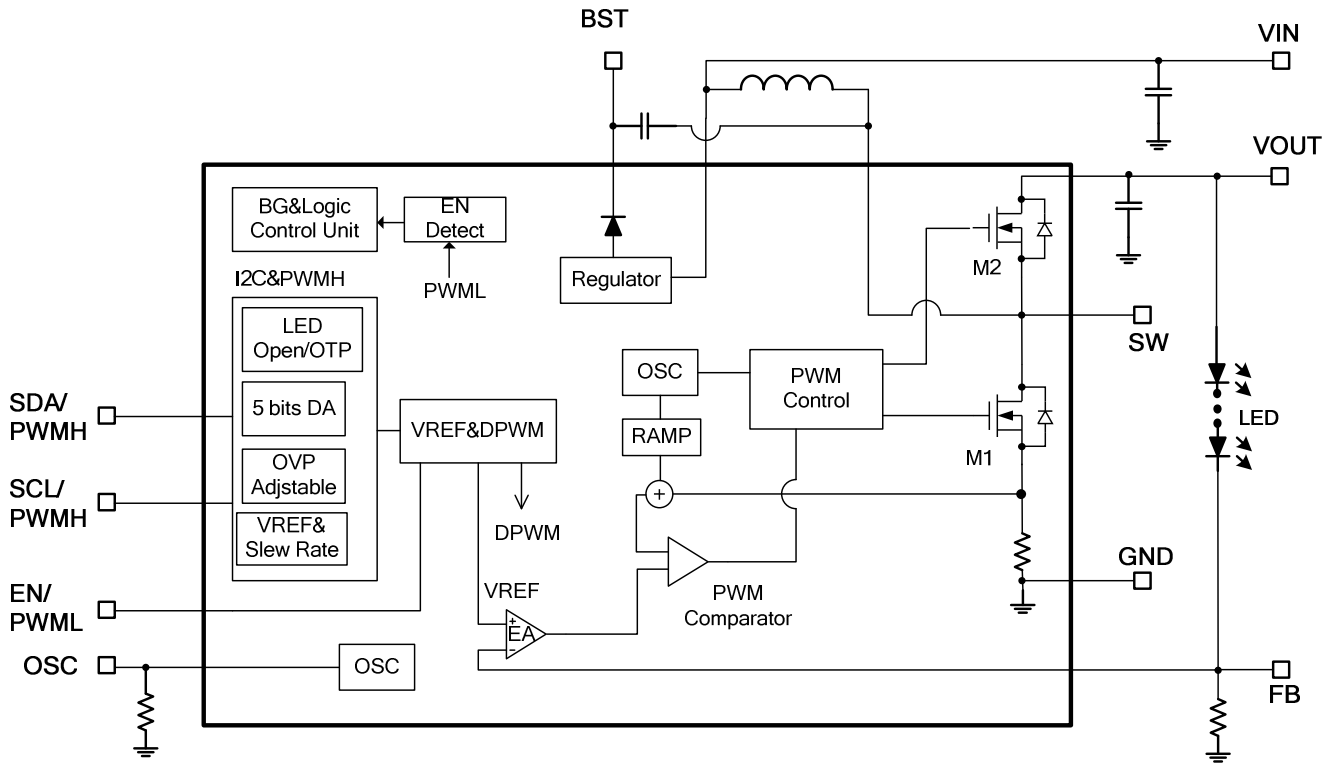

Figure 1: Functional Block Diagram

OPERATION

The MP3309 uses the peak current mode control architecture to regulate the current flowing through the white LEDs string. The operation of the MP3309 can be understood by referring to the function block diagram.

At the start of each oscillator cycle, the control circuit turns on the low-side MOSFET (LS-FET, M1). A stabilizing ramp added to the output of the current-sense amplifier, which then feeds into the positive input of the PWM comparator, prevents sub-harmonic oscillations at duty cycles greater than 50%. When the input to the PWM comparator equals the output voltage of the error amplifier. M1 turns off. Then the inductor current flows through the synchronous power MOSFET or the external Schottky diode, which forces the inductor current to decrease.

The voltage at the output of the error amplifier is the amplified difference between the 200mV reference voltage and the feedback voltage. If the feedback voltage starts to drop, the output of the error amplifier increases, increasing the current flowing through the M1, thus increasing the power to the inductor and output power. This method accurately regulates the LED current.

System Startup

When enabled, the MP3309 checks safety limits, including UVLO and over-temperature protection (OTP), over-current protection after passing the OVP test. If all the protection tests pass, the chip then starts boosting the step-up converter with an internal soft-start. If by software enable, during the soft-start, the reference voltage gradually ramps up with a time step of 320 μ s for a total of 32 steps. If by hardware enable, during soft-start, the current limit drops to 0.8A during startup to prevent a large inrush current. This low-current-limit time lasts for 5ms after the IC is enabled.

Synchronous or Non-synchronous Mode Selection

In default mode (internal register bit SYNC=1), the converter works in synchronous mode. Synchronous mode can reduce diode power consumption caused by a large voltage drop. This synchronous mode increases the

converter efficiency for low LED string voltage. This mode does not need an external Schottky diode to reduce PCB space requirements and BOM costs.

In some applications as below, select non-synchronous mode by setting the internal register bit SYNC=0. Be sure to connect an external schottky diode between SW and VOUT.

1. When the LED string voltage is high, the duty cycle is large, which means the synchronous-power-MOSFET turn-on time is very short;
2. When the switching frequency is set too high, the synchronous power MOSFET driver loss is large.

Dimming Control

The MP3309 provides two dimming methods: PWM and analog dimming mode.

For PWM dimming, apply a PWM signal to the EN/PWML pin. The LED current is then segmented as per the PWM signal and the average LED current equals: $I_{set} \times D_{dim}$. Where D_{dim} is the PWM duty cycle, and I_{set} is the LED current amplitude. When PWM signal is high, the converter operates in normal mode. Conversely, when the PWM amplitude is low, the converter stops switching. Make sure that the PWM-signal low-level time is less than 20ms or the IC will shutdown. Use a 200Hz-to-2kHz PWM-dimming frequency for most dimming ratio requests.

For analog dimming, set the LED current amplitude through I²C interface or an external PWM signal. For MP3309C, control the LED current-regulation voltage by setting the DIMS bit(D0-D4) . For MP3309, implement analog dimming by connecting the SCL and SDA pin together as the PWMH pin and apply a PWM signal. An internal RC filter filters the PWM signal. The LED current amplitude equals $I_{set} \times D_{dim}$, where D_{dim} is the PWM duty cycle and I_{set} is the LED current amplitude. Use a >20kHz PWM signal to improve filtering performance.

Table 1: I²C Reference Voltage Table

	FB Voltage(mV)	D4	D3	D2	D1	D0
0	0	0	0	0	0	0
1	5	0	0	0	0	1
2	8	0	0	0	1	0
3	11	0	0	0	1	1
4	14	0	0	1	0	0
5	17	0	0	1	0	1
6	20	0	0	1	1	0
7	23	0	0	1	1	1
8	26	0	1	0	0	0
9	29	0	1	0	0	1
10	32	0	1	0	1	0
11	35	0	1	0	1	1
12	38	0	1	1	0	0
13	44	0	1	1	0	1
14	50	0	1	1	1	0
15	56	0	1	1	1	1
16	62	1	0	0	0	0
17	68	1	0	0	0	1
18	74	1	0	0	1	0
19	80	1	0	0	1	1
20	86	1	0	1	0	0
21	92	1	0	1	0	1
22	98	1	0	1	1	0
23	104	1	0	1	1	1
24	116	1	1	0	0	0
25	128	1	1	0	0	1
26	140	1	1	0	1	0
27	152	1	1	0	1	1
28	164	1	1	1	0	0
29	176	1	1	1	0	1
30	188	1	1	1	1	0
31	200	1	1	1	1	1

IC Enable and Shutdown

The MP3309 enables the internal band-gap and normal switching if both:

1. The EN/PWML pin is high
2. The internal register EN bit is set to 1.

The MP3309 shuts down the chip if either:

1. The EN/PWML pin is low for longer than 20ms, or
2. The internal register EN bit is set to 0. Note that, if only EN bit set to 1, the bandgap of IC is still active.

Open-String Protection

The MP3309 monitors the VOUT pin for open-string protection. If the LED string is open, the feedback voltage is lower than the reference voltage. The COMP then rises and charges the output capacitor until the VOUT voltage reaches the protection point, V_{OVP}. Select V_{OVP} by setting the internal register bits, OVP0 and OVP1. Please refer to the OVP Protection section in the EC table to select the OVP point.

Selecting a lower OVP protection point permits the use of lower-voltage output capacitor to reduce costs.

The IC stops switching when V_{OUT} reaches the OVP threshold, the IC resumes function when V_{OUT} drops below the threshold.

Input Under-Voltage Protection

When VIN exceeds 2.5V, the converter starts to charge the internal reference and provides power to the internal control circuitry. There is UVLO hysteresis, approximately 200mV, as VIN falls. The IC shuts down when the input voltage drops below 2.3V.

Thermal-Shutdown Protection

Thermal shutdown prevents the IC from operating at exceedingly high temperatures. When the die temperature exceeds the upper threshold (T_{ST}), the IC shutdowns and resumes normal operation when the die temperature drops below lower threshold. Typically, the hysteresis is 25°C.

Fault Indicator

The MP3309C provides several fault register bits to indicate when different protection conditions occur. The host controller can read these fault indication bits. including LED open protection fault, over temperature fault and VUOT to GND fault.

APPLICATION INFORMATION

Selecting the Switching Frequency

The switching frequency of the step-up converter can be programmed from 300kHz to 1.2MHz. A resistor on the OSC pin sets the internal oscillator frequency for the step-up converter as per the equation below:

$$f_{sw}(\text{kHz}) = \frac{120000}{R_{OSC}(\text{k}\Omega)}$$

For instance, if $R_{OSC}=200\text{k}\Omega$, the switching frequency is to 600kHz.

Setting the LED Current

Set the LED current through the current-setting resistor on the FB pin.

$$I_{LED}(\text{mA}) = \frac{V_{REF}(\text{V})}{R_{FB}(\Omega)} \times 1000$$

For instance, if $V_{REF}=200\text{mV}$, and $R_{FB}=10\Omega$, the LED current is 20mA. Do not leave the FB pin floating.

Selecting the Input Capacitor

The input capacitor reduces the surge current drawn from the input supply and the switching noise from the device. The input capacitor impedance at the switching frequency should be less than the input source impedance to prevent the high-frequency switching current from passing through to the input. Use ceramic capacitors with X5R or X7R dielectrics for their low ESR and small temperature coefficients. For most applications, use a 2.2 μF -to-10 μF ceramic capacitor.

Selecting the Inductor

The MP3309 requires an inductor to boost its output voltage. A larger value inductor results in less ripple current, lowering both the peak-inductor current and the stress on the internal N-channel MOSFET. However, the larger inductor is physically larger, has a higher series resistance, and a lower saturation current.

Choose an inductor that does not saturate under the worst-case load conditions. Select the minimum inductor value to ensure that the boost converter works in continuous-conduction mode with high efficiency and good EMI performance.

Calculate the required inductance value using

the equation:

$$L \geq \frac{\eta \times V_{OUT} \times D \times (1-D)^2}{2 \times f_{sw} \times I_{LOAD}}$$

$$D = 1 - \frac{V_{IN}}{V_{OUT}}$$

Where V_{IN} and V_{OUT} are the input and output voltages, f_{sw} is the switching frequency, I_{LOAD} is the LED load current, and η is the efficiency.

The switching current for peak-current mode. To avoid hitting the current limit, the worst-case inductor peak current should be less than 80% of the current limit, I_{LIM} .

Selecting the Output Capacitor

The output capacitor keeps the output voltage ripple small and ensures feedback loop stability. The output capacitor impedance must be low at the switching frequency. Ceramic capacitors with X7R dielectrics are recommended for their low ESR characteristics. Selection must also account for the capacitance's dependence on the voltage rating; with a DC bias voltage, the capacitor can lose as much as 50% of its capacitance at its rated voltage rating. Leave a sufficient voltage rating margin when select the component.

Too-low or too-high capacitance will cause loop instability. For most applications, select a capacitor in the range of 0.1 μF to 1 μF .

Setting the Over-Voltage Protection Point

V_{OUT} determines the OVP point for open-string protection. In some cases, an LED string failure results in a 0V feedback voltage. The part then continuously boosts the output voltage higher and higher until the output voltage reaches the programmed OVP threshold to trigger open-string protection.

Select an OVP protection point through the I²C interface—about 1.1 to 1.2 times higher than the output voltage for normal operation. An appropriate OVP voltage can also allow for low-voltage output capacitors.

Mode	OVP Point
OVP0=0,OVP1=1(Default)	36V
OVP0=1,OVP1=0	24V
OVP0=0,OVP1=0	15V

Selecting the External Schottky Diode

Non-synchronous mode (internal register bit SYNC=0) requires an external free-wheeling diode between the SW and VOUT pins. To optimize efficiency, use a high-speed and low-reverse-recovery-current Schottky diode. Make sure the diode's average and peak current rating exceeds the output average LED current and the peak inductor current. In addition, the diode's breakdown voltage rating should exceed the maximum voltage across the diode. Usually, unexpected high-frequency voltage spikes on the diode occur when the diode turns off. Therefore, leave some voltage-rating margin to guarantee normal long-term operation.

Internal Soft Start

By software enable on, to prevent a large inrush current and provide a smooth startup, the MP3309 has a reference rising/falling slew rate. The time is 320µs per step for a total of 32 steps from 0 to 200mV.

By Hardware enable on, IL current limit drop to half to prevent inrush during startup.

I²C Register

I²C Chip Address:

The device address for the MP3309 is 0x17. After the START condition, the I²C-compatible master sends a seven-bit address followed by an eighth read (Read: 1) or write (Write: 0) bit. The following byte indicates the register address to/from which the data will be written/read.

0	0	1	0	1	1	1	R/W
---	---	---	---	---	---	---	-----

The I²C Compatible Device Address

Register Descriptions:

Part Number	Register Address	Default/Reset Value
MP3309	0X00	111111XX
	0X01	X1101000
MP3309C	0X00	011111XX
	0X01	X0101000

0x00 Register Descriptions:

EN	D0	D1	D2	D3	D4	X	X
----	----	----	----	----	----	---	---

EN: IC enable bit. Default=1 for MP3309, Default=0 for MP3309C.

D0:D4: Reference set bits. Default=11111.

X: Reserved Bits.

0x01 Register Descriptions:

X	DIMS	SYNC	OVP0	OPV1	VOS	LEDO	OTP
---	------	------	------	------	-----	------	-----

X: Reserved Bits.

DIMS: Dimming Mode Select. Connect SCK and SDA together and apply a PWM signal to this pin if setting this bit to 1. Use the I²C to write to D0 through D4 directly if setting this pin to 0. Default=1 for MP3309, Default=0 for MP3309C.

SYNC: Synchronous Mode Select. 1: Synchronous, 0: Non-synchronous.

OVP0:OPV1: OVP Protection Point Set. Default=01.

VOS: VOUT short to GND Fault. Read only. Default=0.

LEDO: LED Open-Protection Fault. Read only. Default=0.

OTP: Over Temperature Protection Fault. Read only. Default=0

Layout Considerations

Careful attention must be paid to the PCB board layout and components placement. Proper layout of the high frequency switching path is critical to prevent noise and limit electromagnetic interference. The loop consisting of MP3309's internal low-side MOSFET, synchronous MOSFET or diode, and output capacitor contains a high-frequency ripple current—minimize this loop. Place the input and output capacitor should as to the IC as possible.

TYPICAL APPLICATION CIRCUITS

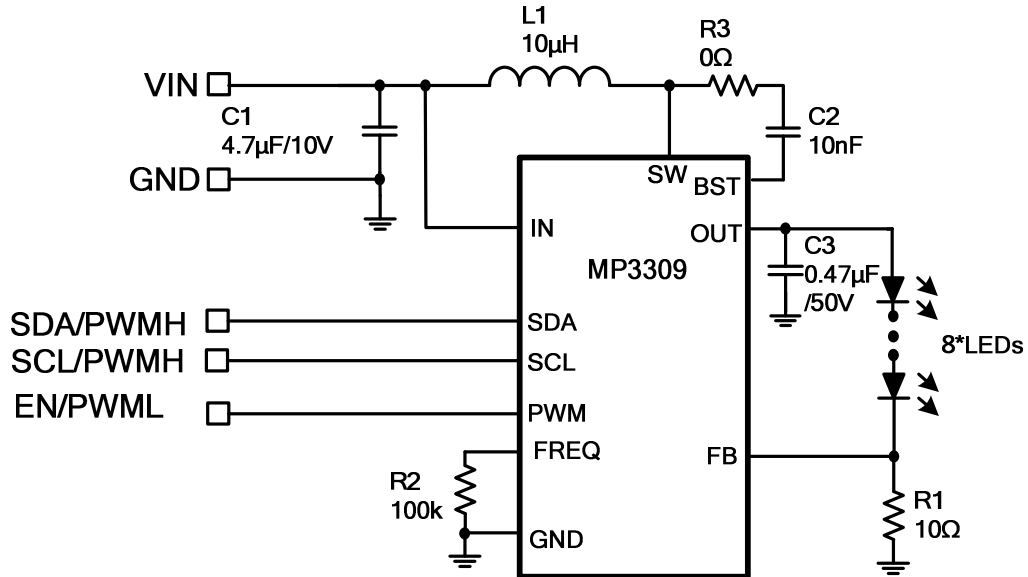

Figure 2: Typical Application for Single String 8LEDs

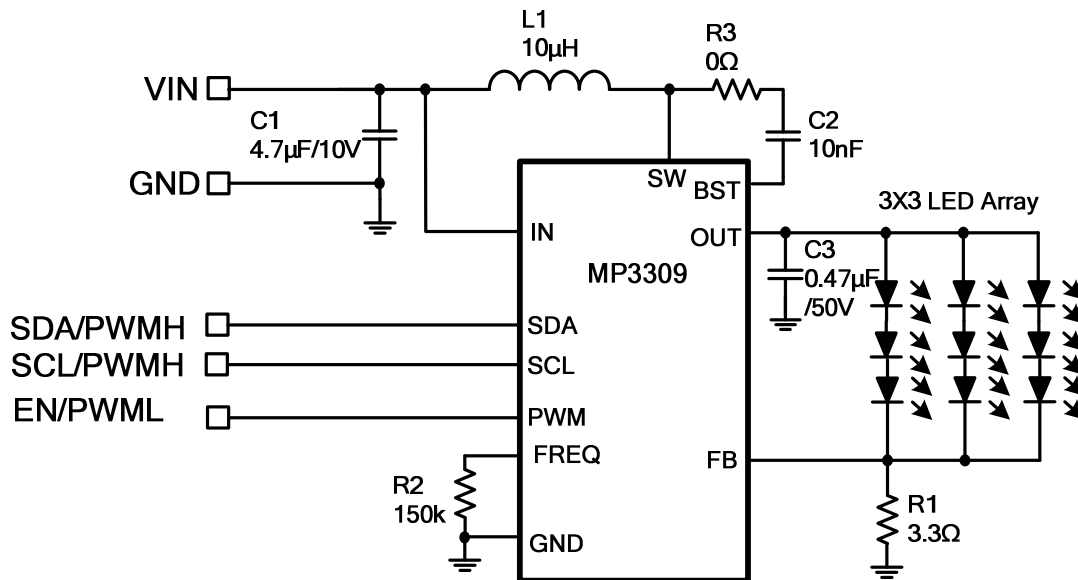
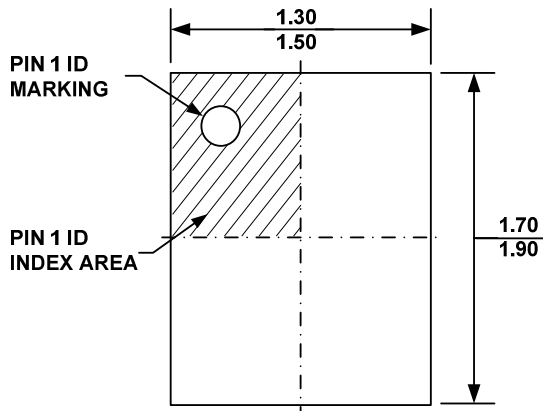

Figure 3: Typical Application for 3X3 LED Array

PACKAGE INFORMATION

QFN-10 (1.4mmX1.8mm)



TOP VIEW

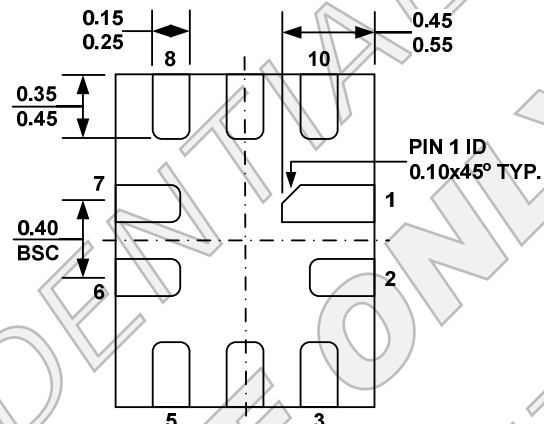

BOTTOM VIEW

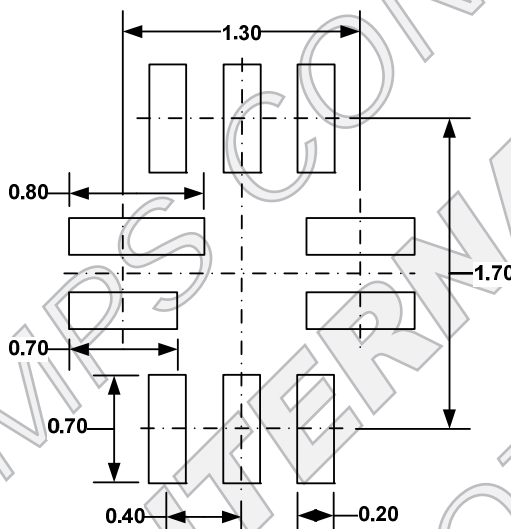

RECOMMENDED LAND PATTERN

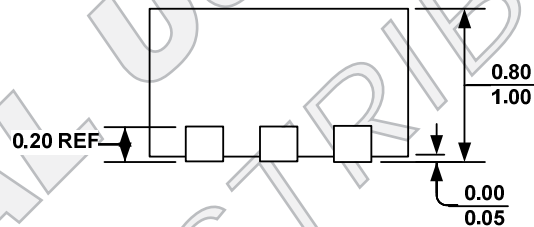

SIDE VIEW



NOTE:

- 1) ALL DIMENSIONS ARE IN MILLIMETERS.
- 2) EXPOSED PADDLE SIZE DOES NOT INCLUDE MOLD FLASH.
- 3) LEAD COPLANARITY SHALL BE 0.10 MILLIMETER MAX.
- 4) JEDEC REFERENCE IS MO-220.
- 5) DRAWING IS NOT TO SCALE.

NOTICE: The information in this document is subject to change without notice. Please contact MPS for current specifications. Users should warrant and guarantee that third party Intellectual Property rights are not infringed upon when integrating MPS products into any application. MPS will not assume any legal responsibility for any said applications.

Looking for pricing, stock, or lifecycle information?

Click below to explore more details on WIN SOURCE:

-  [View MP3309GQG-Z on WIN SOURCE](#)
-  [Monolithic Power Systems Inc. Information](#)

Optimize Your Supply Chain with WIN SOURCE Solutions

-  Global Sourcing Solution
-  Obsolete Management
-  Cost Control Management
-  Shortage Management
-  Alternative Solution
-  Excess Inventory Management