



**THE DATASHEET OF
ZSH560N8TA**



SUPPLY VOLTAGE MONITOR

ISSUE 2 - JANUARY 2003

ZSH560

DEVICE DESCRIPTION

The ZSH560 is a three terminal under voltage monitor circuit for use in microprocessor systems. The threshold voltage of the device has been set to 4.6 volts making it ideal for 5 volt circuits.

Included in the device is a precise voltage reference and a comparator with built in hysteresis to prevent erratic operation. The ZSH560 features an open collector output capable of sourcing at least 10mA which only requires a single external resistor to interface to following circuits.

Operation of the device is guaranteed from one volt upwards, from this level to the device threshold voltage the output is held high providing a power on reset function. Should the supply voltage, once established, at any time drop below the threshold level then the output again will pull high.

The device is available in a TO92 package for through hole applications as well as SOT223 for surface mount requirements.

FEATURES

- SOT223 and TO92 packages
- Power on reset generator
- Automatic reset generation
- Low standby current
- Guaranteed operation from 1 volt
- Wide supply voltage range
- Internal clamp diode to discharge delay capacitor
- 4.6 volt threshold for 5 volt logic
- 20mV hysteresis prevents erratic operation

APPLICATIONS

- Microprocessor systems
- Computers
- Computer peripherals
- Instrumentation
- Automotive
- Battery powered equipment

SCHEMATIC DIAGRAM

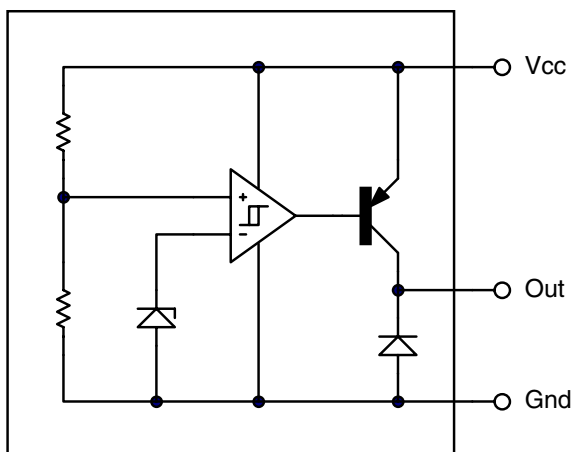

ZSH560

ABSOLUTE MAXIMUM RATING

Input Supply Voltage	-1 to 10V	Power Dissipation	
Offstate Output Voltage	10V	TO92	780mW
Onstate Output Source Current(Note 1)	Internally limited	SOT223	2W(Note 2)
Clamp Diode Forward Current(Note 1)	100mA		
Operating Junction Temperature	150°C		
Operating Temperature	-40 to 85°C		
Storage Temperature	-55 to 150°C		

TEST CONDITIONS

($T_{amb}=25^{\circ}\text{C}$ for typical values, $T_{amb}=-40$ to 85°C for min/max values (Note3))

COMPARATOR

PARAMETER	SYMBOL	MIN	TYP.	MAX.	UNITS
Threshold Voltage Low state output (V_{cc} increasing)	V_{IL}	4.5	4.61	4.7	V
Threshold Voltage High state output (V_{cc} decreasing)	V_{IH}	4.5	4.59	4.7	V
Hysteresis	V_H	0.01	0.02	0.05	V

OUTPUT

PARAMETER	SYMBOL	MIN	TYP.	MAX.	UNITS
Output source saturation: ($V_{cc}=4.0\text{V}$, $I_{source}=8.0\text{mA}$) ($V_{cc}=4.0\text{V}$, $I_{source}=2.0\text{mA}$) ($V_{cc}=1.0\text{V}$, $I_{source}=2\mu\text{A}$)	V_{OH}			$V_{CC}-1.3$ $V_{CC}-1.2$ $V_{CC}-0.4$	V V V
Onstate output source current ($V_{cc}=4.0\text{V}$, Output=0V)	I_{source}	10	20	50	mA
Offstate output leakage current ($V_{cc}=5.0\text{V}$, Output=0V)	I_{oh}		0.02	0.5	μA
Clamp diode forward voltage ($I_f=10\text{mA}$)	V_f	0.6	1.2	1.5	V
Propagation delay (V_{in} 5V to 4V, $R_I=10\text{k}$, $T_{amb}=25^{\circ}\text{C}$)	T_d		1.5		μs

TOTAL DEVICE

PARAMETER	SYMBOL	MIN	TYP.	MAX.	UNITS
Operating input voltage range	V_{cc}	1.0 to 6.5			V
Quiescent input current ($V_{cc}=5\text{V}$)	I_q		135	200	μA

Note:

1. Maximum package power dissipation must be observed.
2. Maximum power dissipation for the SOT223 package is calculated assuming that the device is mounted on a PCB measuring 2 inches square.
3. Low duty cycle pulse techniques are used during test to maintain junction temperatures as close to ambient as possible.

ZSH560

TYPICAL CHARACTERISTICS

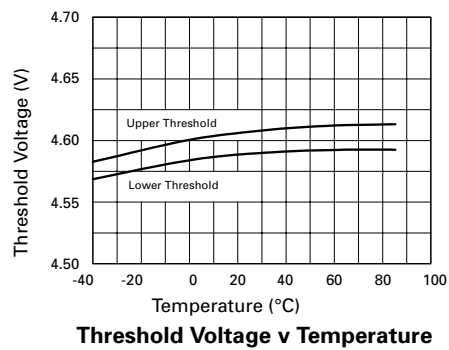
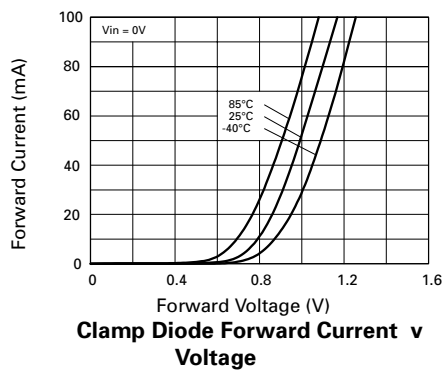
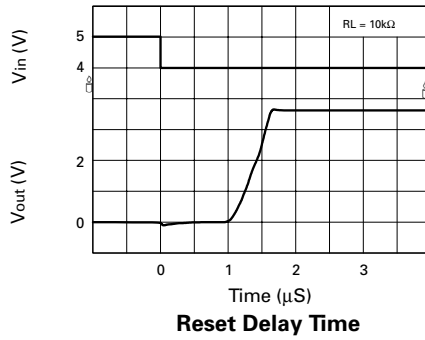
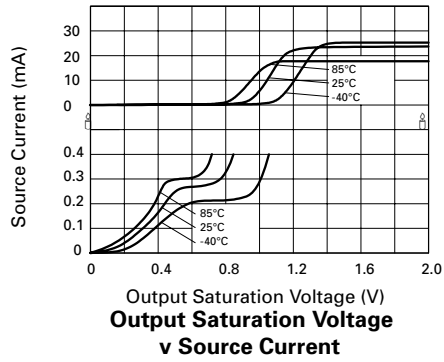
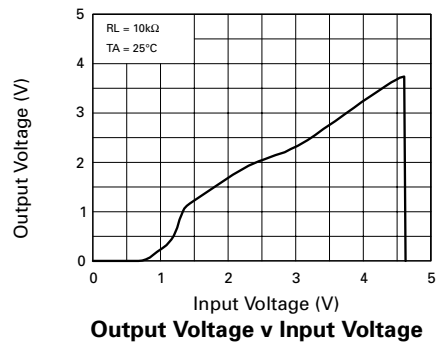
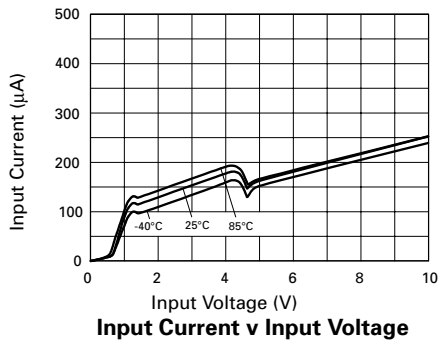

ZSH560

TIMING DIAGRAM

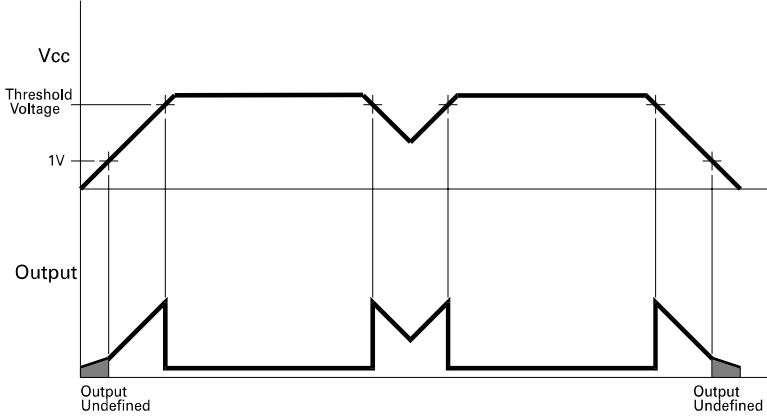

APPLICATION CIRCUIT

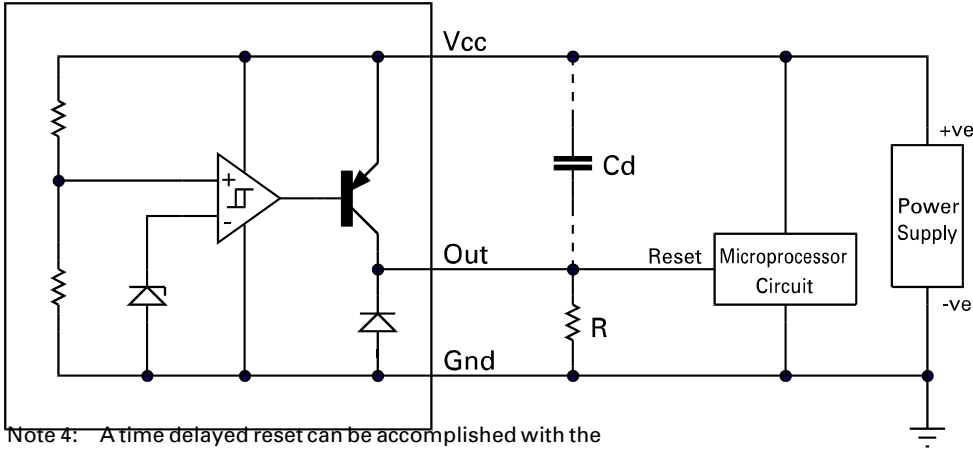

Note 4: A time delayed reset can be accomplished with the additional Cd.

$$T_{DY} = RCd \left[\ln \left(\frac{1}{\frac{V_{TH}}{V_{in}}} \right) - \ln \left(\frac{1}{1 - \frac{V_{SAT}}{V_{in}}} \right) \right]$$

T_{DY} =Time (Seconds)
 V_{TH} =Microprocessor Reset Threshold (ground referenced)
 V_{SAT} =Output Saturation Voltage (from Output Saturation Voltage characteristic)
 V_{in} =Power Supply Voltage

ZSH560

CONNECTION DIAGRAMS

SOT223 Package Suffix - G

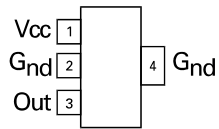

Top View –
Connect pin 4 to pin 2 or leave pin 4 electrically isolated

TO92 Package Suffix - C

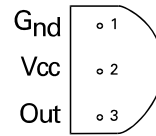



Bottom View

ORDERING INFORMATION

Part No	Package	Partmark
ZSH560C	TO92	ZSH560
ZSH560G	SOT223	ZSH560

Looking for pricing, stock, or lifecycle information?

Click below to explore more details on WIN SOURCE:

-  [View ZSH560N8TA on WIN SOURCE](#)
-  [Diodes Incorporated Information](#)

Optimize Your Supply Chain with WIN SOURCE Solutions

-  Global Sourcing Solution
-  Obsolete Management
-  Cost Control Management
-  Shortage Management
-  Alternative Solution
-  Excess Inventory Management