

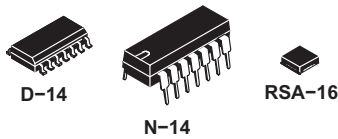

**THE DATASHEET OF  
SN65LBC180RSATG4**





## LOW-POWER RS-485 LINE DRIVER AND RECEIVER PAIRS

### FEATURES

- Designed for High-Speed Multipoint Data Transmission Over Long Cables
- Operate With Pulse Durations as Low as 30 ns
- Low Supply Current . . . 5 mA Max
- Meet or Exceed the Requirements of ANSI Standard RS-485 and ISO 8482:1987(E)
- 3-State Outputs for Party-Line Buses
- Common-Mode Voltage Range of  $-7\text{ V}$  to  $12\text{ V}$
- Thermal Shutdown Protection Prevents Driver Damage From Bus Contention
- Positive and Negative Output Current Limiting
- Pin Compatible With the SN75ALS180

### DESCRIPTION

The SN55LBC180, SN65LBC180 and SN75LBC180 differential driver and receiver pairs are monolithic integrated circuits designed for bidirectional data communication over long cables that take on the characteristics of transmission lines. They are balanced, or differential, voltage mode devices that meet or exceed the requirements of industry standards ANSI RS-485 and ISO 8482:1987(E). These devices are designed using TI's proprietary LinBiCMOS™ with the low-power consumption of CMOS and the precision and robustness of bipolar transistors in the same circuit.

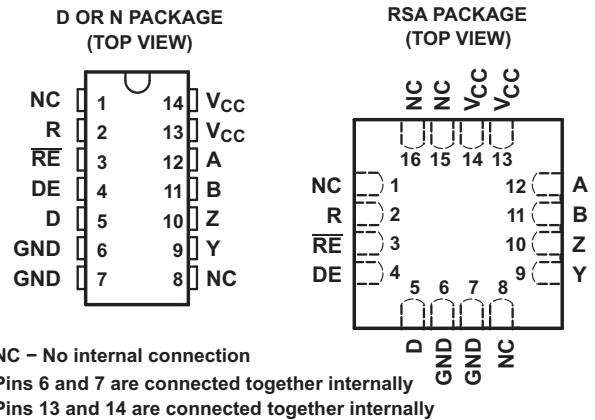

### logic diagram (positive logic)

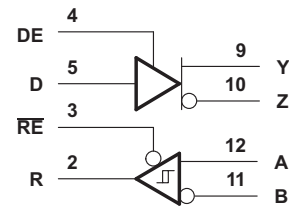

### ORDERING INFORMATION

T <sub>A</sub>	PACKAGE	PART NUMBER	PART MARKING
0°C to 70°C	PDIP	SN75LBC180N	SN75LBC180N
	SOIC	SN75LBC180D	7LB180
	QFN	SN75LBC180RSA	LB180
-40°C to 85°C	PDIP	SN65LBC180N	65LBC180N
	SOIC	SN65LBC180D	6LB180
	QFN	SN65LBC180RSA	BL180
-55°C to 125°C	QFN	SN55LBC180RSA	SN55LBC180



Please be aware that an important notice concerning availability, standard warranty, and use in critical applications of Texas Instruments semiconductor products and disclaimers thereto appears at the end of this data sheet.

LinBiCMOS is a trademark of Texas Instruments.



These devices have limited built-in ESD protection. The leads should be shorted together or the device placed in conductive foam during storage or handling to prevent electrostatic damage to the MOS gates.

## DESCRIPTION (CONTINUED)

The SN55LBC180, SN65LBC180 and SN75LBC180 combine a differential line driver and receiver with 3-state outputs and operate from a single 5-V supply. The driver and receiver have active-high and active-low enables, respectively, which can be externally connected to function as a direction control. The driver differential outputs and the receiver differential inputs are connected to separate terminals for full-duplex operation and are designed to present minimum loading to the bus whether disabled or powered off ( $V_{CC} = 0$ ). These parts feature a wide common-mode voltage range making them suitable for point-to-point or multipoint data-bus applications.

The devices also provide positive and negative output-current limiting and thermal shutdown for protection from line fault conditions. The line driver shuts down at a junction temperature of approximately 172°C.

The SN75LBC180 is characterized for operation over the commercial temperature range of 0°C to 70°C. The SN65LBC180 is characterized over the industrial temperature range of -40°C to 85°C.

The SN55LBC180 is characterized for operation over the military temperature range of -55°C to 125°C.

FUNCTION TABLES<sup>(1)</sup>

DRIVER			
INPUT D	ENABLE DE	OUTPUTS	
		Y	Z
H	H	H	L
L	H	L	H
X	L	Z	Z
RECEIVER			
DIFFERENTIAL INPUTS A-B	ENABLE RE	OUTPUT R	
$V_{ID} \geq 0.2 \text{ V}$	L	H	
$-0.2 \text{ V} < V_{ID} < 0.2 \text{ V}$	L	?	
$V_{ID} \leq -0.2 \text{ V}$	L	L	
X	H	Z	
Open circuit	L	H	

(1) H = high level, L = low level, ? = Indeterminate, X = irrelevant,  
 Z = high impedance (off)

## ABSOLUTE MAXIMUM RATINGS<sup>(1)</sup>

			UNIT	
V <sub>CC</sub>	Supply voltage range <sup>(2)</sup>	–0.3 to 7	V	
V <sub>BUS</sub>	Bus voltage range (A, B, Y, Z) <sup>(2)</sup>	–10 to 15	V	
	Voltage range at D, R, DE, $\overline{RE}$ <sup>(2)</sup>	–0.3 to V <sub>CC</sub> + 0.5	V	
	Continuous total power dissipation <sup>(3)</sup>	Internally limited		
	Total power dissipation	See Dissipation Rating Table		
T <sub>stg</sub>	Storage temperature range	–65 to 150	°C	
I <sub>O</sub>	Receiver output current range	–50 to 50	mA	
ESD	Electrostatic discharge	HBM (Human Body Model) EIA/JESD22-A114	±4	kV
		MM (Machine Model) EIA/JESD22-A115	400	V
		CDM (Charge Device Model) EIA/JESD22-C101	1.5	kV

- (1) Stresses beyond those listed under *absolute maximum ratings* may cause permanent damage to the device. These are stress ratings only, and functional operation of the device at these or any other conditions beyond those indicated under *recommended operating conditions* is not implied. Exposure to absolute-maximum-rated conditions for extended periods may affect device reliability.
- (2) All voltage values are with respect to GND.
- (3) The maximum operating junction temperature is internally limited. Use the dissipation rating table to operate below this temperature.

## DISSIPATION RATING TABLE

PACKAGE <sup>(1)</sup>	T <sub>A</sub> ≤ 25°C POWER RATING	DERATING FACTOR ABOVE T <sub>A</sub> = 25°C	T <sub>A</sub> = 70°C POWER RATING	T <sub>A</sub> = 85°C POWER RATING	T <sub>A</sub> = 125°C POWER RATING
D	950 mW	7.6 mW/°C	608 mW	494 mW	—
N	1150 mW	9.2 mW/°C	736 mW	598 mW	—
RSA	3333 mW	26.67 mW/°C	2133 mW	1733 mW	400 mW

- (1) For the most current package and ordering information, see the Package Option Addendum at the end of this document, or see the TI Web site at [www.ti.com](http://www.ti.com).

## RECOMMENDED OPERATING CONDITIONS

			MIN	NOM	MAX	UNIT
V <sub>CC</sub>	Supply voltage		4.75	5	5.25	V
V <sub>IH</sub>	High-level input voltage	D, DE, and $\overline{RE}$	2			V
V <sub>IL</sub>	Low-level input voltage	D, DE, and $\overline{RE}$			0.8	V
V <sub>ID</sub>	Differential input voltage		–6 <sup>(1)</sup>		6	V
V <sub>O</sub> , V <sub>I</sub> , or V <sub>IC</sub>	Voltage at any bus terminal (separately or common mode)	A, B, Y, or Z	–7 <sup>(1)</sup>		12	V
I <sub>OH</sub>	High-level output current	Y or Z			–60	mA
		R			–8	
I <sub>OL</sub>	Low-level output current	Y or Z			60	mA
		R			8	
T <sub>A</sub>	Operating free-air temperature	SN55LBC180	–55		125	°C
		SN65LBC180	–40		85	
		SN75LBC180	0		70	

- (1) The algebraic convention where the least positive (more negative) limit is designated minimum, is used in this data sheet for the differential input voltage, voltage at any bus terminal, operating temperature, input threshold voltage, and common-mode output voltage.

## DRIVER SECTION

### ELECTRICAL CHARACTERISTICS

over recommended operating conditions (unless otherwise noted)

PARAMETER		TEST CONDITIONS		MIN	TYP <sup>(1)</sup>	MAX	UNIT
$V_{IK}$	Input clamp voltage	$I_I = -18 \text{ mA}$				-1.5	V
$ V_{OD} $	Differential output voltage magnitude <sup>(2)</sup>	$R_L = 54 \Omega$ , See <a href="#">Figure 1</a>	SN55LBC180	1	2.5	5	V
			SN65LBC180	1.1	2.5	5	
			SN75LBC180	1.5	2.5	5	
		$R_L = 60 \Omega$ , See <a href="#">Figure 2</a>	SN55LBC180	1	2.5	5	
			SN65LBC180	1.1	2	5	
			SN75LBC180	1.5	2	5	
$\Delta V_{OD} $	Change in magnitude of differential output voltage <sup>(3)</sup>	See <a href="#">Figure 1</a> and <a href="#">Figure 2</a>				$\pm 0.2$	V
$V_{OC}$	Common-mode output voltage			1	2.5	3	V
$\Delta V_{OC} $	Change in magnitude of common-mode output voltage <sup>(3)</sup>	$R_L = 54 \Omega$ ,	See <a href="#">Figure 1</a>			$\pm 0.2$	V
$I_O$	Output current with power off	$V_{CC} = 0$ ,	$V_O = -7 \text{ V to } 12 \text{ V}$			$\pm 100$	$\mu\text{A}$
$I_{OZ}$	High-impedance-state output current	$V_O = -7 \text{ V to } 12 \text{ V}$				$\pm 100$	$\mu\text{A}$
$I_{IH}$	High-level input current	$V_I = 2.4 \text{ V}$				100	$\mu\text{A}$
$I_{IL}$	Low-level input current	$V_I = 0.4 \text{ V}$				100	$\mu\text{A}$
$I_{OS}$	Short-circuit output current	$-7 \text{ V} \leq V_O \leq 12 \text{ V}$				$\pm 250$	mA
$I_{CC}$	Supply current	Receiver disabled	Outputs enabled			5	mA
			Outputs disabled			3	

(1) All typical values are at  $V_{CC} = 5 \text{ V}$  and  $T_A = 25^\circ\text{C}$ .

(2) The minimum  $V_{OD}$  specification may not fully comply with ANSI RS-485 at operating temperatures below  $0^\circ\text{C}$ . System designers should take the possibly lower output signal into account in determining the maximum signal-transmission distance.

(3)  $\Delta|V_{OD}|$  and  $\Delta|V_{OC}|$  are the changes in the steady-state magnitude of  $V_{OD}$  and  $V_{OC}$ , respectively, that occur when the input is changed from a high level to a low level.

### SWITCHING CHARACTERISTICS

$V_{CC} = 5 \text{ V}$ ,  $T_A = 25^\circ\text{C}$

PARAMETER		TEST CONDITIONS		MIN	TYP	MAX	UNIT
$t_{d(OD)}$	Differential output delay time	$R_L = 54 \Omega$ ,	See <a href="#">Figure 3</a>	7	12	18	ns
$t_{t(OD)}$	Differential output transition time			5	10	20	ns
$t_{PZH}$	Output enable time to high level	$R_L = 110 \Omega$ ,	See <a href="#">Figure 4</a>			35	ns
$t_{PZL}$	Output enable time to low level	$R_L = 110 \Omega$ ,	See <a href="#">Figure 5</a>			35	ns
$t_{PHZ}$	Output disable time from high level	$R_L = 110 \Omega$ ,	See <a href="#">Figure 4</a>			50	ns
$t_{PLZ}$	Output disable time from low level	$R_L = 110 \Omega$ ,	See <a href="#">Figure 5</a>			35	ns

### SWITCHING CHARACTERISTICS (SN55LBC180)

$V_{CC} = 5 \text{ V}$ ,  $T_A = 25^\circ\text{C}$

PARAMETER		TEST CONDITIONS		MIN	TYP	MAX	UNIT
$t_{d(OD)}$	Differential output delay time	$R_L = 54 \Omega$ ,	See <a href="#">Figure 3</a>		15		ns
$t_{t(OD)}$	Differential output transition time				21		ns
$t_{PZH}$	Output enable time to high level	$R_L = 110 \Omega$ ,	See <a href="#">Figure 4</a>		32		ns
$t_{PHZ}$	Output disable time from high level				55		
$t_{PZL}$	Output enable time to low level	$R_L = 110 \Omega$ ,	See <a href="#">Figure 5</a>		32		ns
$t_{PLZ}$	Output disable time from low level				20		

## RECEIVER SECTION

### ELECTRICAL CHARACTERISTICS

over recommended operating conditions (unless otherwise noted)

PARAMETER	TEST CONDITIONS	MIN	TYP	MAX	UNIT
$V_{IT+}$ Positive-going input threshold voltage	$I_O = -8 \text{ mA}$			0.2	V
$V_{IT-}$ Negative-going input threshold voltage	$I_O = 8 \text{ mA}$	-0.2			V
$V_{hys}$ Hysteresis voltage ( $V_{IT+} - V_{IT-}$ )			45		mV
$V_{IK}$ Enable-input clamp voltage	$I_I = -18 \text{ mA}$	-1.5			V
$V_{OH}$ High-level output voltage	$V_{ID} = 200 \text{ mV}$ , $I_{OH} = -8 \text{ mA}$	3.5	4.5		V
$V_{OL}$ Low-level output voltage	$V_{ID} = -200 \text{ mV}$ , $I_{OL} = 8 \text{ mA}$		0.3	0.5	V
$I_{OZ}$ High-impedance-state output current	$V_O = 0 \text{ V to } V_{CC}$			$\pm 20$	$\mu\text{A}$
$I_{IH}$ High-level enable-input current	$V_{IH} = 2.4 \text{ V}$	-50			A
$I_{IL}$ Low-level enable-input current	$V_{IL} = 0.4 \text{ V}$	-100			$\mu\text{A}$
$I_I$ Bus input current	$V_I = 12 \text{ V}$ , $V_{CC} = 5 \text{ V}$ , Other input at 0 V		0.7	1	mA
	$V_I = 12 \text{ V}$ , $V_{CC} = 0 \text{ V}$ , Other input at 0 V		0.8	1	
	$V_I = -7 \text{ V}$ , $V_{CC} = 5 \text{ V}$ , Other input at 0 V	-0.8	-0.5		
	$V_I = -7 \text{ V}$ , $V_{CC} = 0 \text{ V}$ , Other input at 0 V	-0.8	-0.5		
$I_{CC}$ Supply current	Driver disabled	Outputs enabled		5	mA
		Outputs disabled		3	

### SWITCHING CHARACTERISTICS

 $V_{CC} = 5 \text{ V}$ ,  $T_A = 25^\circ\text{C}$ 

PARAMETER	TEST CONDITIONS	MIN	TYP	MAX	UNIT
$t_{PHL}$ Propagation delay time, high- to low-level output	$V_{ID} = -1.5 \text{ V to } 1.5 \text{ V}$ , See <a href="#">Figure 6</a>	11	22	33	ns
$t_{PLH}$ Propagation delay time, low- to high-level output		11	22	33	ns
$t_{sk(p)}$ Pulse skew ( $ t_{PHL} - t_{PLH} $ )			3	6	ns
$t_t$ Transition time				5	8
$t_{PZH}$ Output enable time to high level	See <a href="#">Figure 7</a>			35	ns
$t_{PZL}$ Output enable time to low level				30	ns
$t_{PHZ}$ Output disable time from high level				35	ns
$t_{PLZ}$ Output disable time from low level				30	ns

### SWITCHING CHARACTERISTICS (SN55LBC180)

 $V_{CC} = 5 \text{ V}$ ,  $T_A = 25^\circ\text{C}$ 

PARAMETER	TEST CONDITIONS	MIN	TYP	MAX	UNIT
$t_{PHL}$ Propagation delay time, high- to low-level output	$V_{ID} = -1.5 \text{ V to } 1.5 \text{ V}$ , See <a href="#">Figure 6</a>		26		ns
$t_{PLH}$ Propagation delay time, low- to high-level output			23		ns
$t_{sk(p)}$ Pulse skew ( $ t_{PHL} - t_{PLH} $ )			3		ns
$t_{sk(p)t}$ Transition time			4		ns
$t_{PZH}$ Output enable time to high level	See <a href="#">Figure 4</a>		30		ns
$t_{PHZ}$ Output disable time from high level			26		ns
$t_{PZL}$ Output enable time to low level			30		ns
$t_{PLZ}$ Output disable time from low level			30		ns

PARAMETER MEASUREMENT INFORMATION

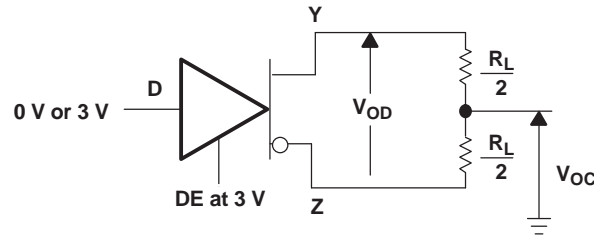

Figure 1. Differential and Common-Mode Output Voltages

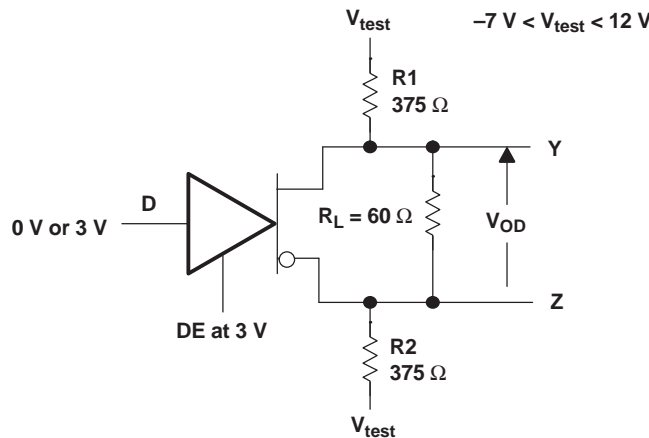
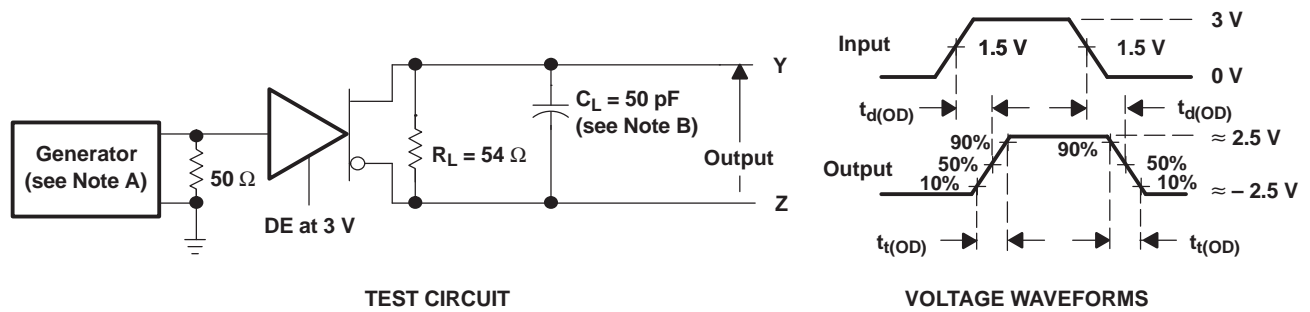

Figure 2. Driver  $V_{OD}$  Test Circuit



- NOTES: A. The input pulse is supplied by a generator having the following characteristics: PRR > 1 MHz, 50% duty cycle,  $t_r \leq 6$  ns,  $t_f \leq 6$  ns,  $Z_O = 50 \Omega$ .  
 B.  $C_L$  includes probe and jig capacitance.

Figure 3. Driver Test Circuit and Differential Output Delay and Transition Time Voltage Waveforms

PARAMETER MEASUREMENT INFORMATION (continued)

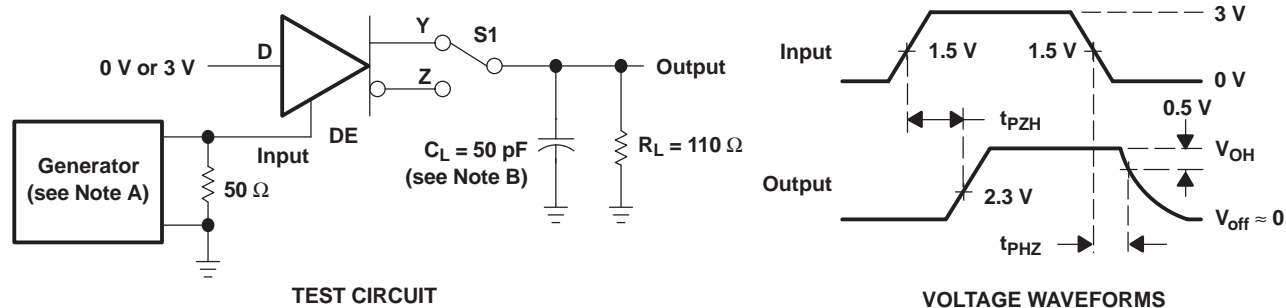

Figure 4. Driver Test Circuit and Enable and Disable Time Waveforms

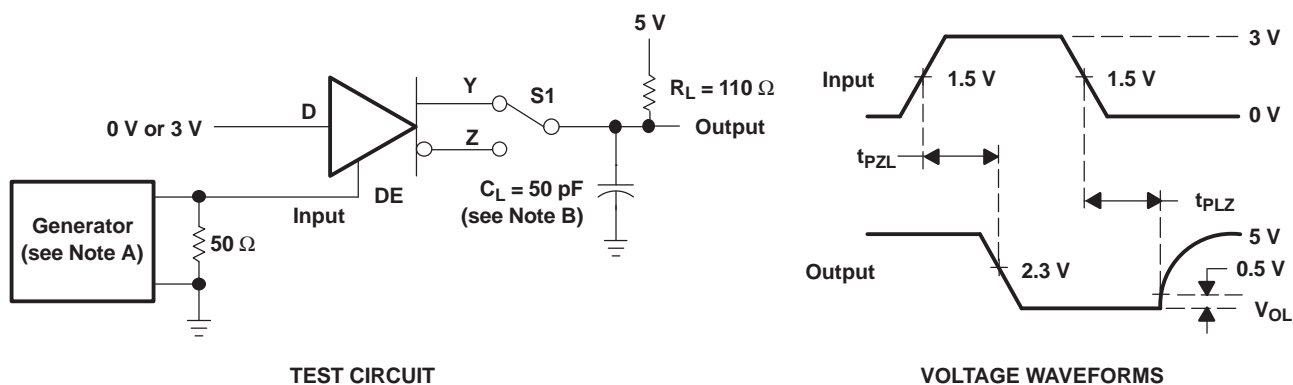
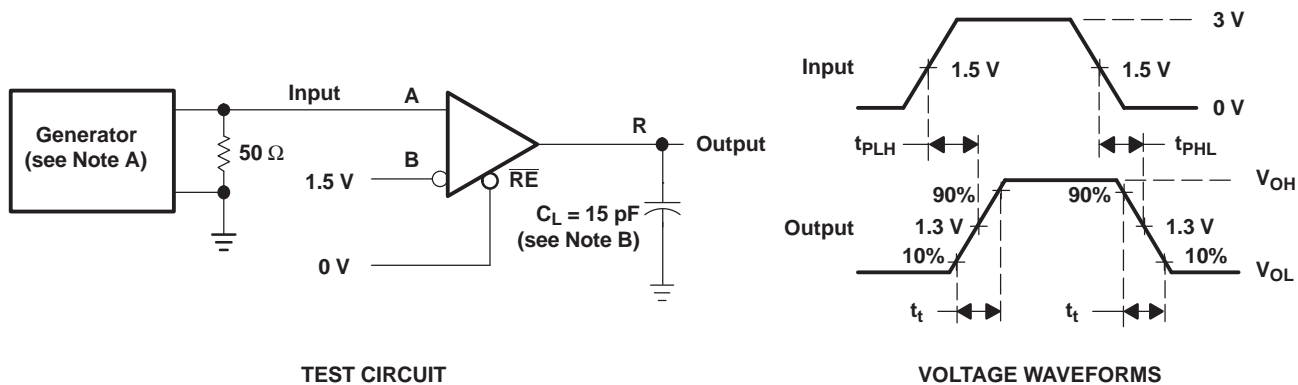

Figure 5. Driver Test Circuit and Enable and Disable Time Voltage Waveforms



- NOTES: A. The input pulse is supplied by a generator having the following characteristics: PRR ≤ 1 MHz, 50% duty cycle,  $t_r \leq 6$  ns,  $t_f \leq 6$  ns,  $Z_0 = 50 \Omega$ .  
B.  $C_L$  includes probe and jig capacitance.

Figure 6. Receiver Test Circuit and Propagation Delay Time Voltage Waveforms

PARAMETER MEASUREMENT INFORMATION (continued)

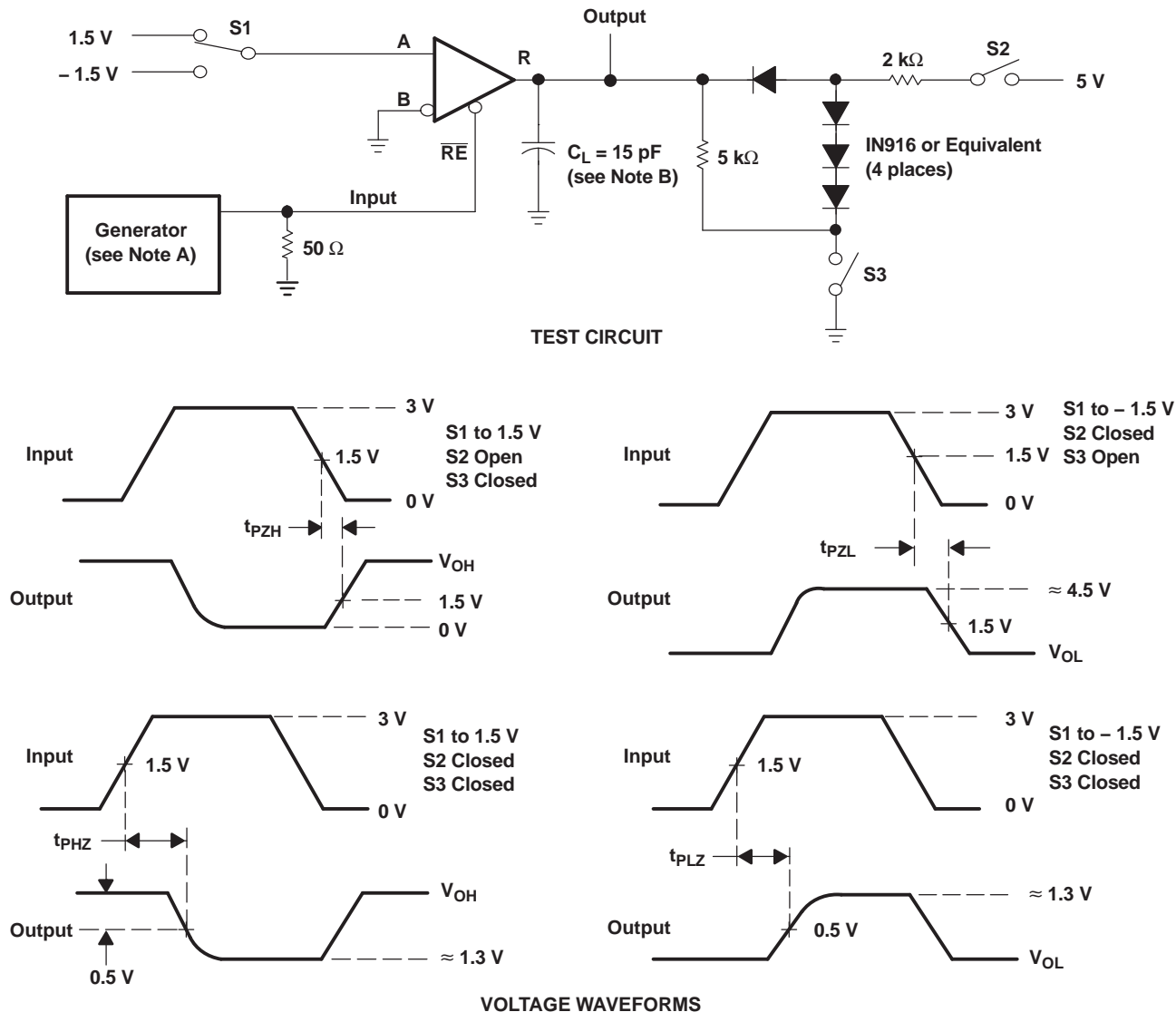

NOTES: A. The input pulse is supplied by a generator having the following characteristics: PRR  $\leq$  1 MHz, 50% duty cycle,  $t_r \leq$  6 ns,  $t_f \leq$  6 ns,  $Z_O = 50 \Omega$ .  
 B.  $C_L$  includes probe and jig capacitance.

Figure 7. Receiver Output Enable and Disable Times

TYPICAL CHARACTERISTICS

SCHEMATICS OF INPUTS AND OUTPUTS

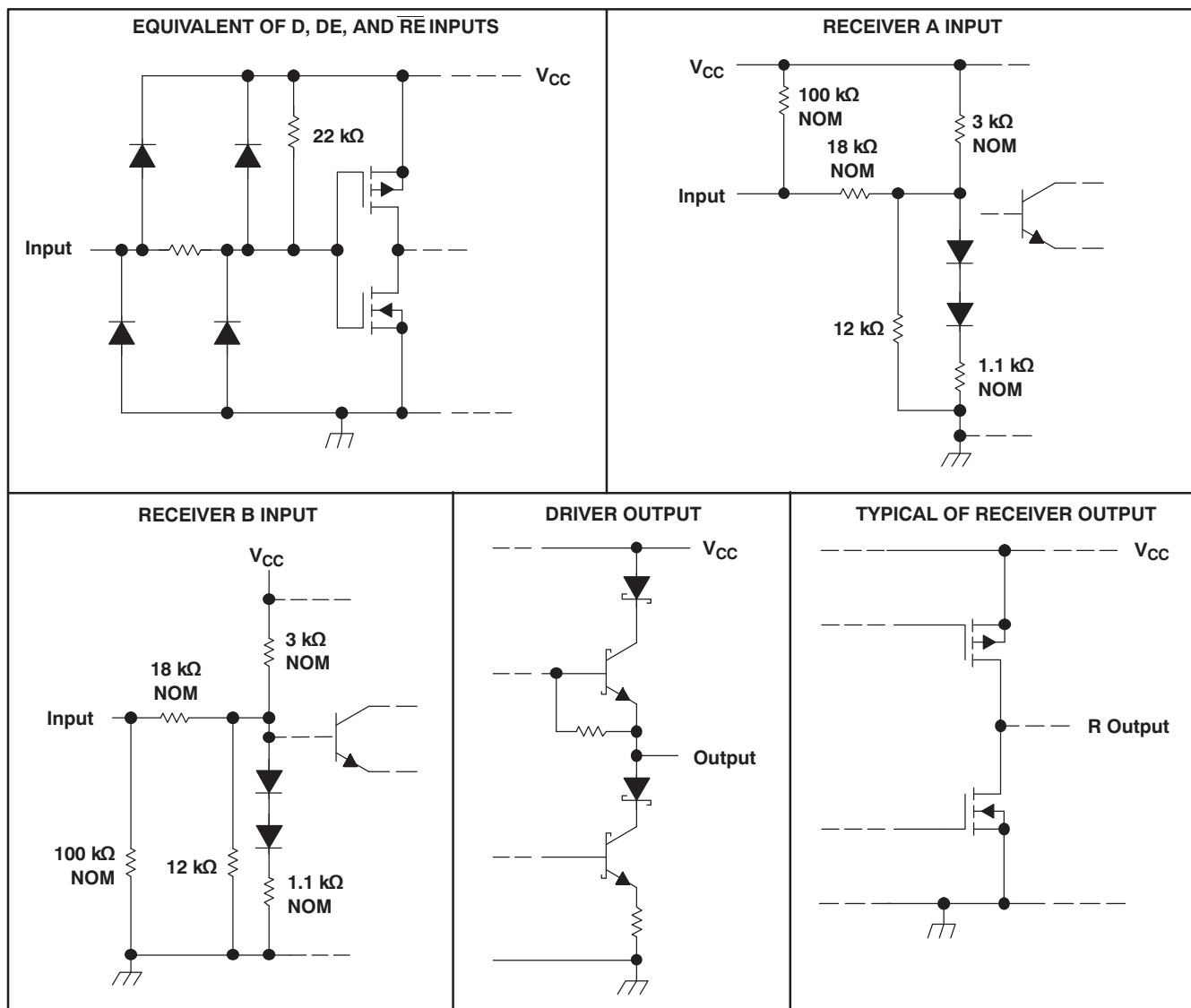

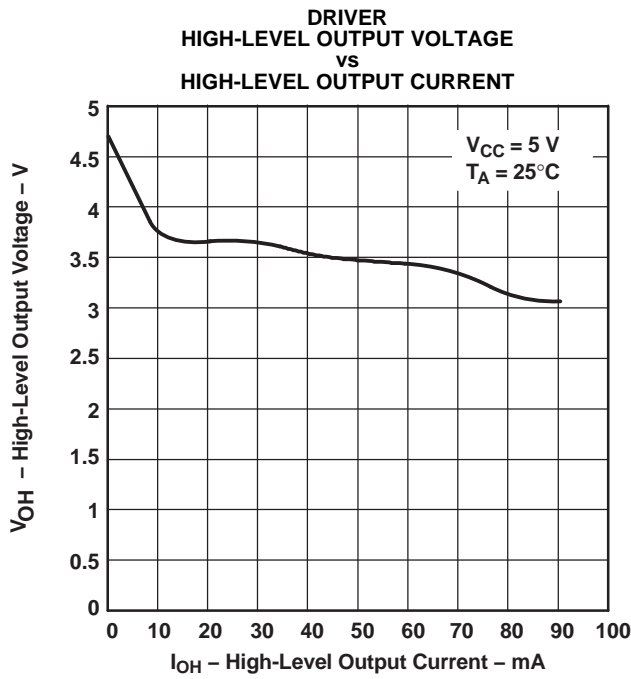

Figure 8.

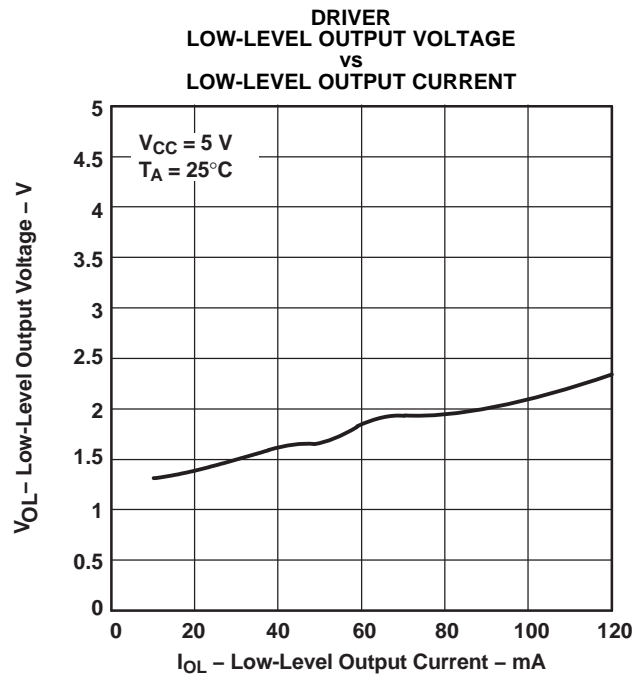

Figure 9.

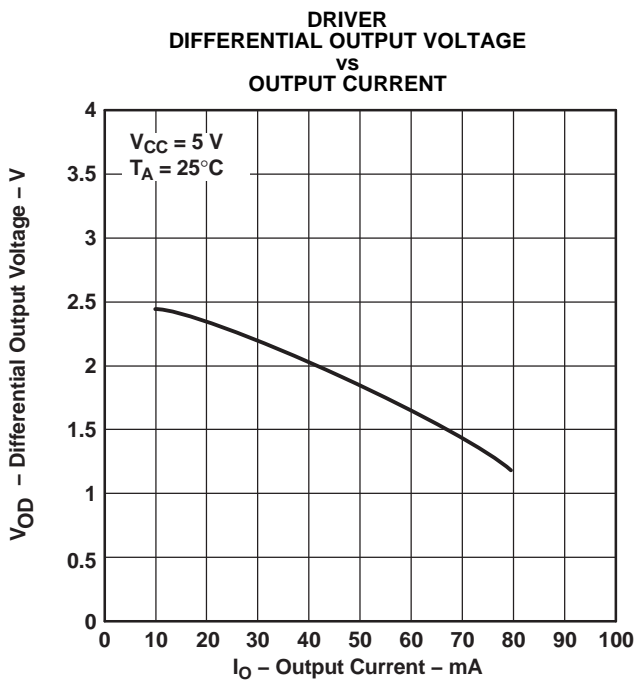

Figure 10.

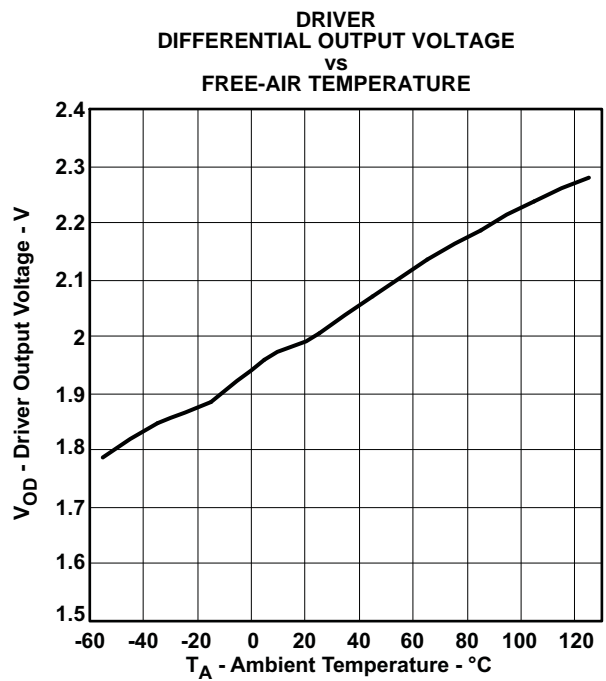

Figure 11.

DRIVER  
DIFFERENTIAL DELAY TIMES  
vs  
FREE-AIR TEMPERATURE

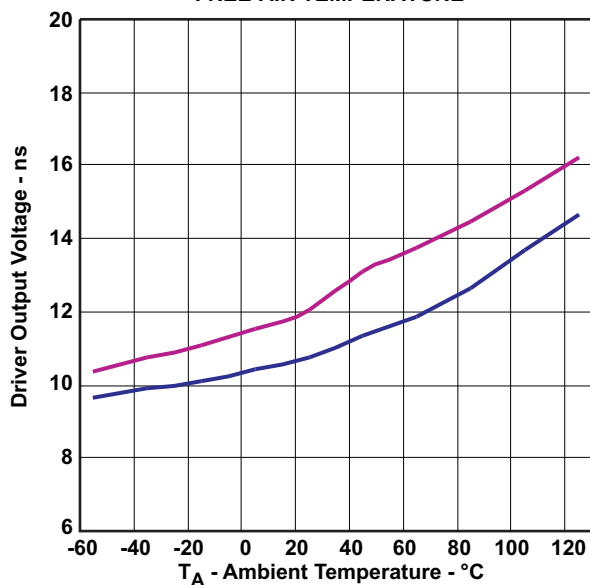

Figure 12.

DRIVER  
OUTPUT CURRENT  
vs  
SUPPLY VOLTAGE

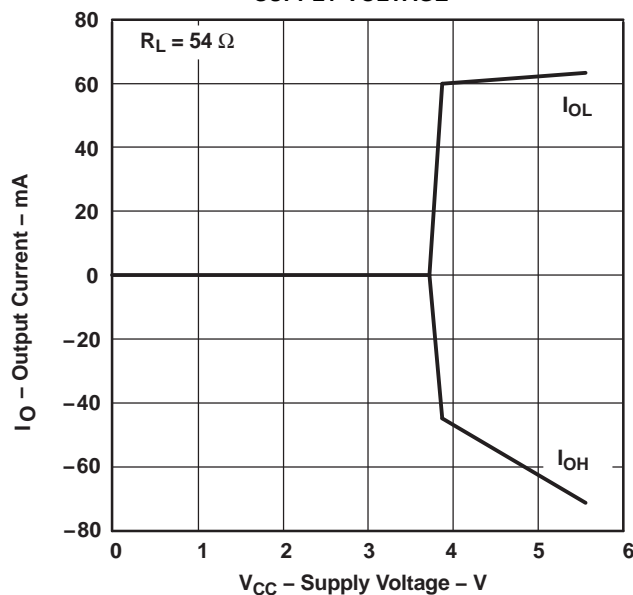

Figure 13.

RECEIVER  
HIGH-LEVEL OUTPUT VOLTAGE  
vs  
HIGH-LEVEL OUTPUT CURRENT

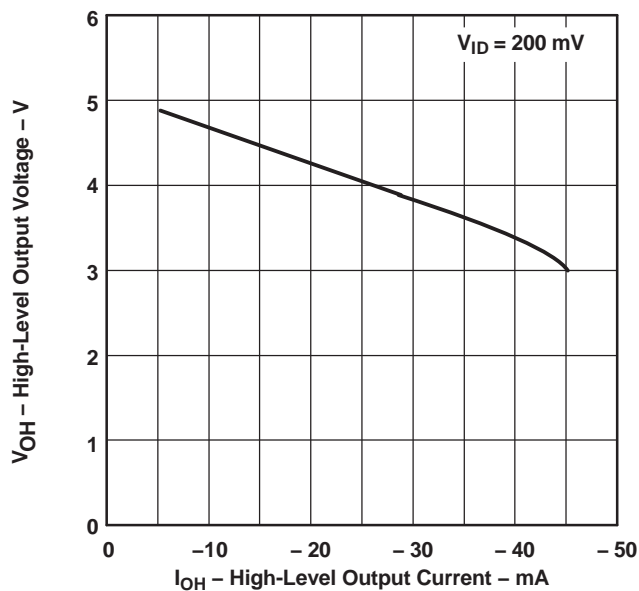

Figure 14.

RECEIVER  
LOW-LEVEL OUTPUT VOLTAGE  
vs  
LOW-LEVEL OUTPUT CURRENT

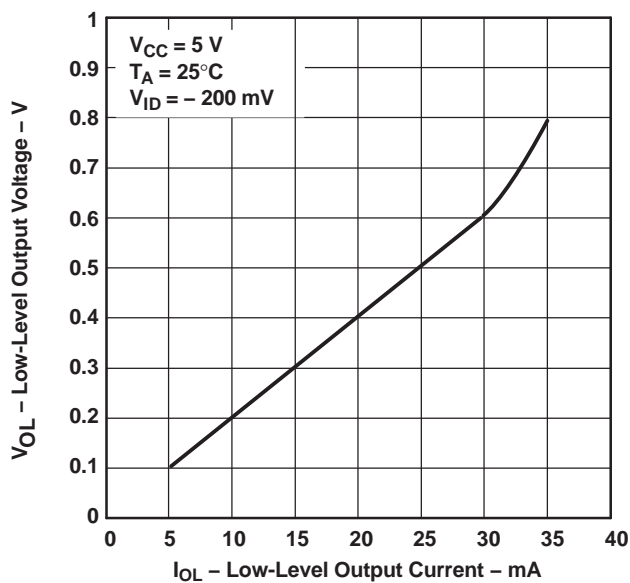
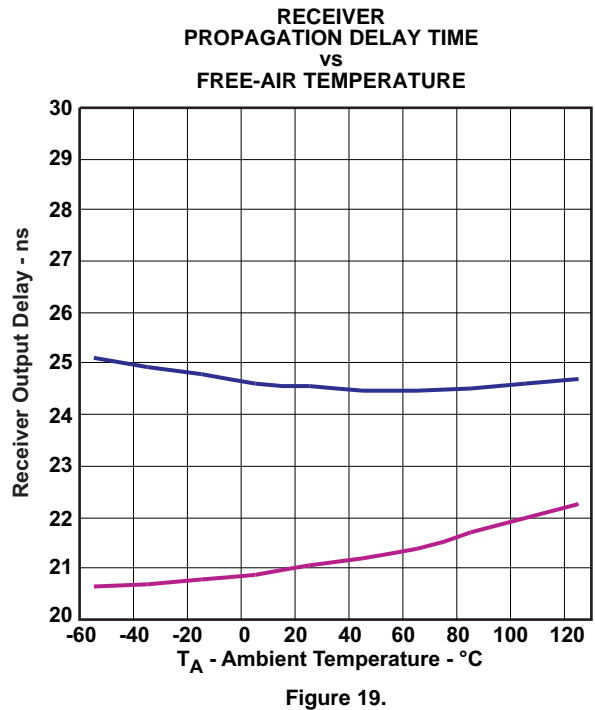
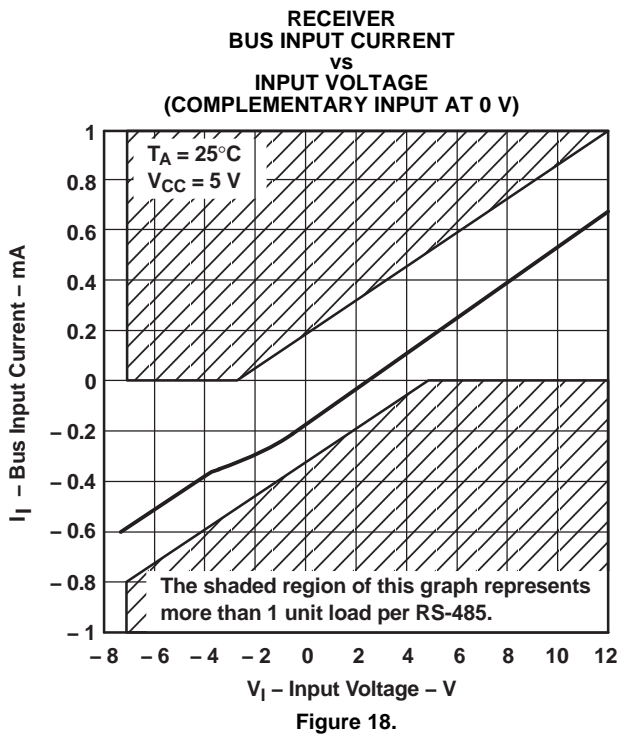
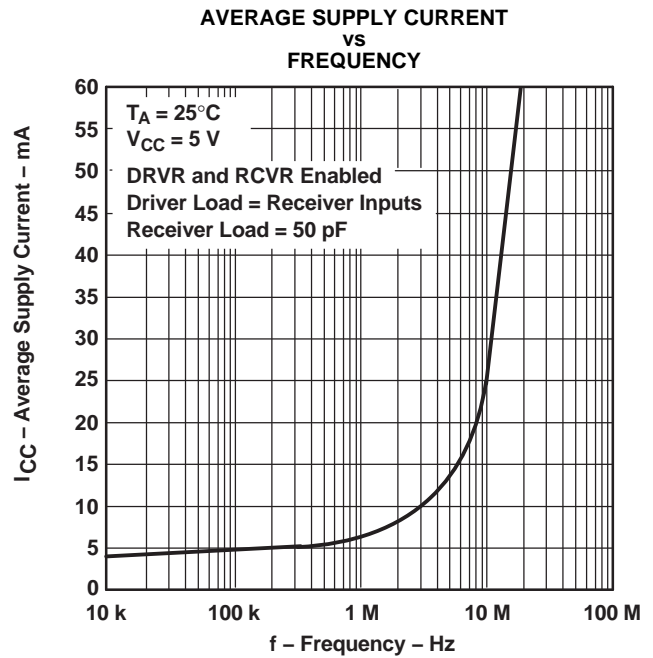
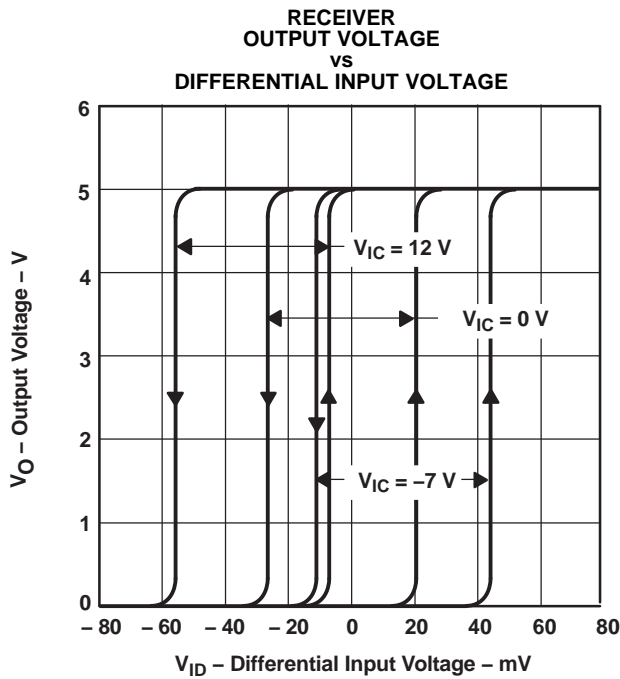

Figure 15.



### APPLICATION INFORMATION

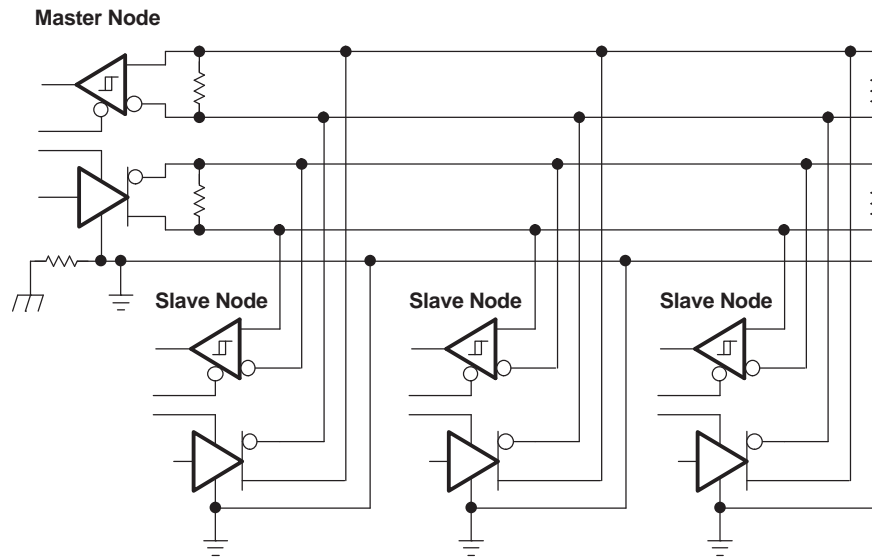

Figure 20. Full Duplex Application Circuit

**PACKAGING INFORMATION**

Orderable Device	Status (1)	Package Type	Package Drawing	Pins	Package Qty	Eco Plan (2)	Lead/Ball Finish (6)	MSL Peak Temp (3)	Op Temp (°C)	Device Marking (4/5)	Samples
SN55LBC180RSAR	ACTIVE	QFN	RSA	16	3000	Green (RoHS & no Sb/Br)	CU NIPDAU	Level-2-260C-1 YEAR	-55 to 125	SN55 LBC180	<a href="#">Samples</a>
SN55LBC180RSAT	ACTIVE	QFN	RSA	16	250	Green (RoHS & no Sb/Br)	CU NIPDAU	Level-2-260C-1 YEAR	-55 to 125	SN55 LBC180	<a href="#">Samples</a>
SN65LBC180D	ACTIVE	SOIC	D	14	50	Green (RoHS & no Sb/Br)	CU NIPDAU	Level-1-260C-UNLIM	-40 to 85	6LB180	<a href="#">Samples</a>
SN65LBC180DR	ACTIVE	SOIC	D	14	2500	Green (RoHS & no Sb/Br)	CU NIPDAU	Level-1-260C-UNLIM	-40 to 85	6LB180	<a href="#">Samples</a>
SN65LBC180DRG4	ACTIVE	SOIC	D	14	2500	Green (RoHS & no Sb/Br)	CU NIPDAU	Level-1-260C-UNLIM	-40 to 85	6LB180	<a href="#">Samples</a>
SN65LBC180N	ACTIVE	PDIP	N	14	25	Green (RoHS & no Sb/Br)	CU NIPDAU	N / A for Pkg Type	-40 to 85	SN65LBC180N	<a href="#">Samples</a>
SN65LBC180RSAR	ACTIVE	QFN	RSA	16	3000	Green (RoHS & no Sb/Br)	CU NIPDAU	Level-2-260C-1 YEAR	-40 to 85	BL180	<a href="#">Samples</a>
SN65LBC180RSAT	ACTIVE	QFN	RSA	16	250	Green (RoHS & no Sb/Br)	CU NIPDAU	Level-2-260C-1 YEAR	-40 to 85	BL180	<a href="#">Samples</a>
SN65LBC180RSATG4	ACTIVE	QFN	RSA	16	250	Green (RoHS & no Sb/Br)	CU NIPDAU	Level-2-260C-1 YEAR	-40 to 85	BL180	<a href="#">Samples</a>
SN75LBC180D	ACTIVE	SOIC	D	14	50	Green (RoHS & no Sb/Br)	CU NIPDAU	Level-1-260C-UNLIM	0 to 70	7LB180	<a href="#">Samples</a>
SN75LBC180DG4	ACTIVE	SOIC	D	14	50	Green (RoHS & no Sb/Br)	CU NIPDAU	Level-1-260C-UNLIM	0 to 70	7LB180	<a href="#">Samples</a>
SN75LBC180DR	ACTIVE	SOIC	D	14	2500	Green (RoHS & no Sb/Br)	CU NIPDAU	Level-1-260C-UNLIM	0 to 70	7LB180	<a href="#">Samples</a>
SN75LBC180DRG4	ACTIVE	SOIC	D	14	2500	Green (RoHS & no Sb/Br)	CU NIPDAU	Level-1-260C-UNLIM	0 to 70	7LB180	<a href="#">Samples</a>
SN75LBC180N	ACTIVE	PDIP	N	14	25	Green (RoHS & no Sb/Br)	CU NIPDAU	N / A for Pkg Type	0 to 70	SN75LBC180N	<a href="#">Samples</a>
SN75LBC180RSAT	ACTIVE	QFN	RSA	16	250	Green (RoHS & no Sb/Br)	CU NIPDAU	Level-2-260C-1 YEAR	0 to 70	LB180	<a href="#">Samples</a>

(1) The marketing status values are defined as follows:

**ACTIVE:** Product device recommended for new designs.

**LIFEBUY:** TI has announced that the device will be discontinued, and a lifetime-buy period is in effect.

**NRND:** Not recommended for new designs. Device is in production to support existing customers, but TI does not recommend using this part in a new design.

---

**PREVIEW:** Device has been announced but is not in production. Samples may or may not be available.

**OBSOLETE:** TI has discontinued the production of the device.

<sup>(2)</sup> **RoHS:** TI defines "RoHS" to mean semiconductor products that are compliant with the current EU RoHS requirements for all 10 RoHS substances, including the requirement that RoHS substance do not exceed 0.1% by weight in homogeneous materials. Where designed to be soldered at high temperatures, "RoHS" products are suitable for use in specified lead-free processes. TI may reference these types of products as "Pb-Free".

**RoHS Exempt:** TI defines "RoHS Exempt" to mean products that contain lead but are compliant with EU RoHS pursuant to a specific EU RoHS exemption.

**Green:** TI defines "Green" to mean the content of Chlorine (Cl) and Bromine (Br) based flame retardants meet JS709B low halogen requirements of <=1000ppm threshold. Antimony trioxide based flame retardants must also meet the <=1000ppm threshold requirement.

<sup>(3)</sup> MSL, Peak Temp. - The Moisture Sensitivity Level rating according to the JEDEC industry standard classifications, and peak solder temperature.

<sup>(4)</sup> There may be additional marking, which relates to the logo, the lot trace code information, or the environmental category on the device.

<sup>(5)</sup> Multiple Device Markings will be inside parentheses. Only one Device Marking contained in parentheses and separated by a "~" will appear on a device. If a line is indented then it is a continuation of the previous line and the two combined represent the entire Device Marking for that device.

<sup>(6)</sup> Lead/Ball Finish - Orderable Devices may have multiple material finish options. Finish options are separated by a vertical ruled line. Lead/Ball Finish values may wrap to two lines if the finish value exceeds the maximum column width.

**Important Information and Disclaimer:** The information provided on this page represents TI's knowledge and belief as of the date that it is provided. TI bases its knowledge and belief on information provided by third parties, and makes no representation or warranty as to the accuracy of such information. Efforts are underway to better integrate information from third parties. TI has taken and continues to take reasonable steps to provide representative and accurate information but may not have conducted destructive testing or chemical analysis on incoming materials and chemicals. TI and TI suppliers consider certain information to be proprietary, and thus CAS numbers and other limited information may not be available for release.

In no event shall TI's liability arising out of such information exceed the total purchase price of the TI part(s) at issue in this document sold by TI to Customer on an annual basis.

**OTHER QUALIFIED VERSIONS OF SN55LBC180, SN65LBC180, SN75LBC180 :**

● Catalog: [SN75LBC180](#)

● Automotive: [SN65LBC180-Q1](#)

● Military: [SN55LBC180](#)

NOTE: Qualified Version Definitions:

● Catalog - TI's standard catalog product

- Automotive - Q100 devices qualified for high-reliability automotive applications targeting zero defects
- Military - QML certified for Military and Defense Applications

**TAPE AND REEL INFORMATION**

**QUADRANT ASSIGNMENTS FOR PIN 1 ORIENTATION IN TAPE**

\*All dimensions are nominal

Device	Package Type	Package Drawing	Pins	SPQ	Reel Diameter (mm)	Reel Width W1 (mm)	A0 (mm)	B0 (mm)	K0 (mm)	P1 (mm)	W (mm)	Pin1 Quadrant
SN55LBC180RSAR	QFN	RSA	16	3000	330.0	12.4	4.25	4.25	1.15	8.0	12.0	Q2
SN55LBC180RSAT	QFN	RSA	16	250	180.0	12.4	4.25	4.25	1.15	8.0	12.0	Q2
SN65LBC180DR	SOIC	D	14	2500	330.0	16.4	6.5	9.0	2.1	8.0	16.0	Q1
SN65LBC180RSAR	QFN	RSA	16	3000	330.0	12.4	4.35	4.35	1.1	8.0	12.0	Q2
SN65LBC180RSAR	QFN	RSA	16	3000	330.0	12.4	4.25	4.25	1.15	8.0	12.0	Q2
SN65LBC180RSAT	QFN	RSA	16	250	180.0	12.4	4.25	4.25	1.15	8.0	12.0	Q2
SN65LBC180RSAT	QFN	RSA	16	250	330.0	12.5	4.35	4.35	1.1	8.0	12.0	Q2
SN75LBC180DR	SOIC	D	14	2500	330.0	16.4	6.5	9.0	2.1	8.0	16.0	Q1
SN75LBC180RSAT	QFN	RSA	16	250	180.0	12.4	4.25	4.25	1.15	8.0	12.0	Q2

**TAPE AND REEL BOX DIMENSIONS**

\*All dimensions are nominal

Device	Package Type	Package Drawing	Pins	SPQ	Length (mm)	Width (mm)	Height (mm)
SN55LBC180RSAR	QFN	RSA	16	3000	367.0	367.0	35.0
SN55LBC180RSAT	QFN	RSA	16	250	210.0	185.0	35.0
SN65LBC180DR	SOIC	D	14	2500	333.2	345.9	28.6
SN65LBC180RSAR	QFN	RSA	16	3000	338.0	355.0	50.0
SN65LBC180RSAR	QFN	RSA	16	3000	367.0	367.0	35.0
SN65LBC180RSAT	QFN	RSA	16	250	210.0	185.0	35.0
SN65LBC180RSAT	QFN	RSA	16	250	338.0	355.0	50.0
SN75LBC180DR	SOIC	D	14	2500	333.2	345.9	28.6
SN75LBC180RSAT	QFN	RSA	16	250	210.0	185.0	35.0

RSA (S-PVQFN-N16)

PLASTIC QUAD FLATPACK NO-LEAD

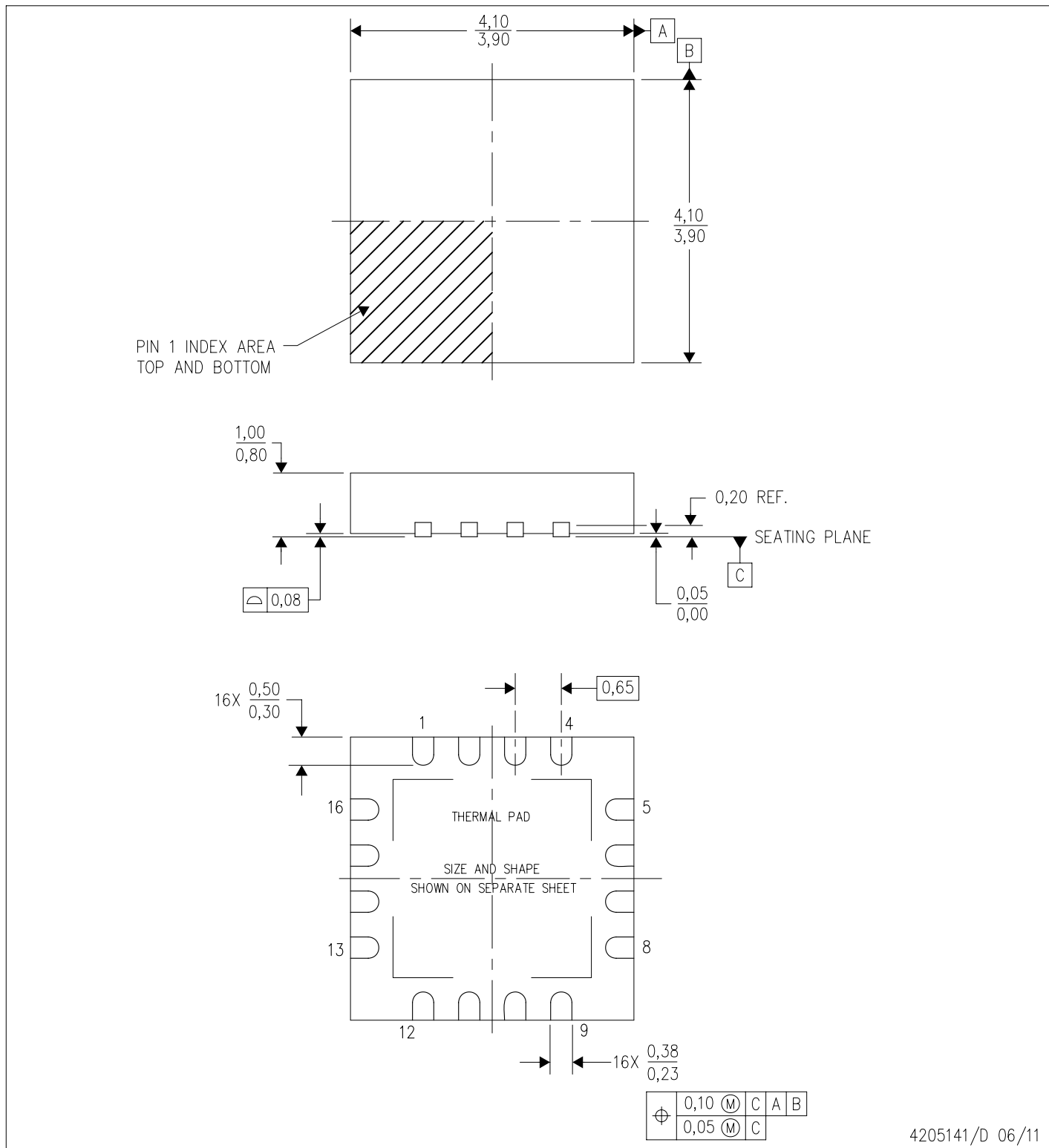

- NOTES:
- All linear dimensions are in millimeters. Dimensioning and tolerancing per ASME Y14.5M-1994.
  - This drawing is subject to change without notice.
  - Quad Flatpack, No-leads (QFN) package configuration.
  - The package thermal pad must be soldered to the board for thermal and mechanical performance.
  - See the additional figure in the Product Data Sheet for details regarding the exposed thermal pad features and dimensions.
  - Falls within JEDEC MO-220.

## THERMAL INFORMATION

This package incorporates an exposed thermal pad that is designed to be attached directly to an external heatsink. The thermal pad must be soldered directly to the printed circuit board (PCB). After soldering, the PCB can be used as a heatsink. In addition, through the use of thermal vias, the thermal pad can be attached directly to the appropriate copper plane shown in the electrical schematic for the device, or alternatively, can be attached to a special heatsink structure designed into the PCB. This design optimizes the heat transfer from the integrated circuit (IC).

For information on the Quad Flatpack No-Lead (QFN) package and its advantages, refer to Application Report, QFN/SON PCB Attachment, Texas Instruments Literature No. SLUA271. This document is available at [www.ti.com](http://www.ti.com).

The exposed thermal pad dimensions for this package are shown in the following illustration.

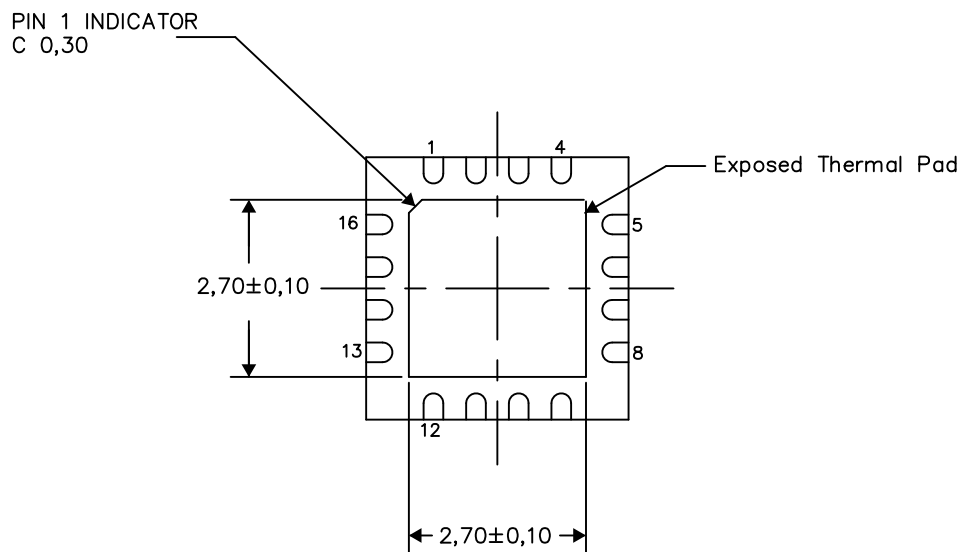

Bottom View

Exposed Thermal Pad Dimensions

4206364-2/0 09/15

### NOTES:

A. All linear dimensions are in millimeters

RSA (S-PVQFN-N16)

PLASTIC QUAD FLATPACK NO-LEAD

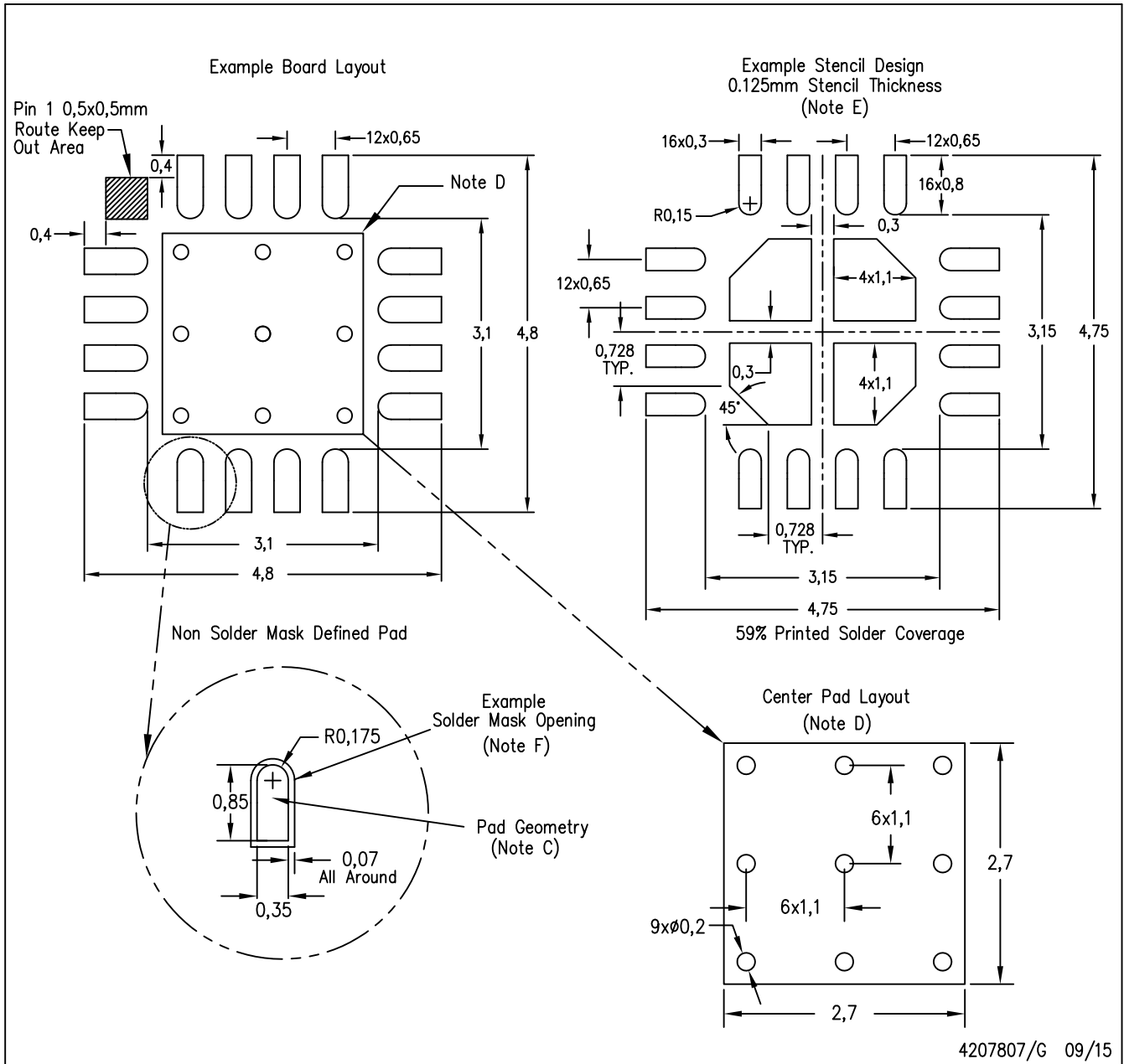

4207807/G 09/15

- NOTES:
- A. All linear dimensions are in millimeters.
  - B. This drawing is subject to change without notice.
  - C. Publication IPC-7351 is recommended for alternate designs.
  - D. This package is designed to be soldered to a thermal pad on the board. Refer to Application Note, QFN Packages, Texas Instruments Literature No. SLUA271, and also the Product Data Sheets for specific thermal information, via requirements, and recommended board layout. These documents are available at [www.ti.com](http://www.ti.com) <<http://www.ti.com>>.
  - E. Laser cutting apertures with trapezoidal walls and also rounding corners will offer better paste release. Customers should contact their board assembly site for stencil design recommendations. Refer to IPC 7525 for stencil design considerations.
  - F. Customers should contact their board fabrication site for solder mask tolerances.



D (R-PDSO-G14)

PLASTIC SMALL OUTLINE



4211283-3/E 08/12

- NOTES:
- All linear dimensions are in millimeters.
  - This drawing is subject to change without notice.
  - Publication IPC-7351 is recommended for alternate designs.
  - Laser cutting apertures with trapezoidal walls and also rounding corners will offer better paste release. Customers should contact their board assembly site for stencil design recommendations. Refer to IPC-7525 for other stencil recommendations.
  - Customers should contact their board fabrication site for solder mask tolerances between and around signal pads.

N (R-PDIP-T\*\*)

PLASTIC DUAL-IN-LINE PACKAGE

16 PINS SHOWN



4040049/E 12/2002

- NOTES:
- A. All linear dimensions are in inches (millimeters).
  - B. This drawing is subject to change without notice.
  - (C) Falls within JEDEC MS-001, except 18 and 20 pin minimum body length (Dim A).
  - (D) The 20 pin end lead shoulder width is a vendor option, either half or full width.

## IMPORTANT NOTICE

Texas Instruments Incorporated (TI) reserves the right to make corrections, enhancements, improvements and other changes to its semiconductor products and services per JESD46, latest issue, and to discontinue any product or service per JESD48, latest issue. Buyers should obtain the latest relevant information before placing orders and should verify that such information is current and complete.

TI's published terms of sale for semiconductor products (<http://www.ti.com/sc/docs/stdterms.htm>) apply to the sale of packaged integrated circuit products that TI has qualified and released to market. Additional terms may apply to the use or sale of other types of TI products and services.

Reproduction of significant portions of TI information in TI data sheets is permissible only if reproduction is without alteration and is accompanied by all associated warranties, conditions, limitations, and notices. TI is not responsible or liable for such reproduced documentation. Information of third parties may be subject to additional restrictions. Resale of TI products or services with statements different from or beyond the parameters stated by TI for that product or service voids all express and any implied warranties for the associated TI product or service and is an unfair and deceptive business practice. TI is not responsible or liable for any such statements.

Buyers and others who are developing systems that incorporate TI products (collectively, "Designers") understand and agree that Designers remain responsible for using their independent analysis, evaluation and judgment in designing their applications and that Designers have full and exclusive responsibility to assure the safety of Designers' applications and compliance of their applications (and of all TI products used in or for Designers' applications) with all applicable regulations, laws and other applicable requirements. Designer represents that, with respect to their applications, Designer has all the necessary expertise to create and implement safeguards that (1) anticipate dangerous consequences of failures, (2) monitor failures and their consequences, and (3) lessen the likelihood of failures that might cause harm and take appropriate actions. Designer agrees that prior to using or distributing any applications that include TI products, Designer will thoroughly test such applications and the functionality of such TI products as used in such applications.

TI's provision of technical, application or other design advice, quality characterization, reliability data or other services or information, including, but not limited to, reference designs and materials relating to evaluation modules, (collectively, "TI Resources") are intended to assist designers who are developing applications that incorporate TI products; by downloading, accessing or using TI Resources in any way, Designer (individually or, if Designer is acting on behalf of a company, Designer's company) agrees to use any particular TI Resource solely for this purpose and subject to the terms of this Notice.

TI's provision of TI Resources does not expand or otherwise alter TI's applicable published warranties or warranty disclaimers for TI products, and no additional obligations or liabilities arise from TI providing such TI Resources. TI reserves the right to make corrections, enhancements, improvements and other changes to its TI Resources. TI has not conducted any testing other than that specifically described in the published documentation for a particular TI Resource.

Designer is authorized to use, copy and modify any individual TI Resource only in connection with the development of applications that include the TI product(s) identified in such TI Resource. NO OTHER LICENSE, EXPRESS OR IMPLIED, BY ESTOPPEL OR OTHERWISE TO ANY OTHER TI INTELLECTUAL PROPERTY RIGHT, AND NO LICENSE TO ANY TECHNOLOGY OR INTELLECTUAL PROPERTY RIGHT OF TI OR ANY THIRD PARTY IS GRANTED HEREIN, including but not limited to any patent right, copyright, mask work right, or other intellectual property right relating to any combination, machine, or process in which TI products or services are used. Information regarding or referencing third-party products or services does not constitute a license to use such products or services, or a warranty or endorsement thereof. Use of TI Resources may require a license from a third party under the patents or other intellectual property of the third party, or a license from TI under the patents or other intellectual property of TI.

TI RESOURCES ARE PROVIDED "AS IS" AND WITH ALL FAULTS. TI DISCLAIMS ALL OTHER WARRANTIES OR REPRESENTATIONS, EXPRESS OR IMPLIED, REGARDING RESOURCES OR USE THEREOF, INCLUDING BUT NOT LIMITED TO ACCURACY OR COMPLETENESS, TITLE, ANY EPIDEMIC FAILURE WARRANTY AND ANY IMPLIED WARRANTIES OF MERCHANTABILITY, FITNESS FOR A PARTICULAR PURPOSE, AND NON-INFRINGEMENT OF ANY THIRD PARTY INTELLECTUAL PROPERTY RIGHTS. TI SHALL NOT BE LIABLE FOR AND SHALL NOT DEFEND OR INDEMNIFY DESIGNER AGAINST ANY CLAIM, INCLUDING BUT NOT LIMITED TO ANY INFRINGEMENT CLAIM THAT RELATES TO OR IS BASED ON ANY COMBINATION OF PRODUCTS EVEN IF DESCRIBED IN TI RESOURCES OR OTHERWISE. IN NO EVENT SHALL TI BE LIABLE FOR ANY ACTUAL, DIRECT, SPECIAL, COLLATERAL, INDIRECT, PUNITIVE, INCIDENTAL, CONSEQUENTIAL OR EXEMPLARY DAMAGES IN CONNECTION WITH OR ARISING OUT OF TI RESOURCES OR USE THEREOF, AND REGARDLESS OF WHETHER TI HAS BEEN ADVISED OF THE POSSIBILITY OF SUCH DAMAGES.

Unless TI has explicitly designated an individual product as meeting the requirements of a particular industry standard (e.g., ISO/TS 16949 and ISO 26262), TI is not responsible for any failure to meet such industry standard requirements.

Where TI specifically promotes products as facilitating functional safety or as compliant with industry functional safety standards, such products are intended to help enable customers to design and create their own applications that meet applicable functional safety standards and requirements. Using products in an application does not by itself establish any safety features in the application. Designers must ensure compliance with safety-related requirements and standards applicable to their applications. Designer may not use any TI products in life-critical medical equipment unless authorized officers of the parties have executed a special contract specifically governing such use. Life-critical medical equipment is medical equipment where failure of such equipment would cause serious bodily injury or death (e.g., life support, pacemakers, defibrillators, heart pumps, neurostimulators, and implantables). Such equipment includes, without limitation, all medical devices identified by the U.S. Food and Drug Administration as Class III devices and equivalent classifications outside the U.S.

TI may expressly designate certain products as completing a particular qualification (e.g., Q100, Military Grade, or Enhanced Product). Designers agree that it has the necessary expertise to select the product with the appropriate qualification designation for their applications and that proper product selection is at Designers' own risk. Designers are solely responsible for compliance with all legal and regulatory requirements in connection with such selection.

Designer will fully indemnify TI and its representatives against any damages, costs, losses, and/or liabilities arising out of Designer's non-compliance with the terms and provisions of this Notice.

## Looking for pricing, stock, or lifecycle information?

Click below to explore more details on WIN SOURCE:

 [View SN65LBC180RSATG4 on WIN SOURCE](#)

 [Texas Instruments](#) Information

## Optimize Your Supply Chain with WIN SOURCE Solutions

-  Global Sourcing Solution
-  Obsolete Management
-  Cost Control Management
-  Shortage Management
-  Alternative Solution
-  Excess Inventory Management