



**THE DATASHEET OF
DRV10963JADSNT**



DRV10963 5-V, Three-Phase, Sensorless BLDC Motor Driver

1 Features

- Proprietary Sensor-less Window-less 180° Sinusoidal Control Scheme
- Input Voltage Range 2.1 to 5.5 V
- 500-mA Output Current
- Low Quiescent Current 15 μ A (Typical) at Sleep Mode
- Total Driver H+L R_{dson} Less than 1.5 Ω
- Current Limit and Short Circuit Current Protection
- Lock Detection
- Anti Voltage Surge (AVS)
- UVLO
- Thermal Shutdown

2 Applications

- Notebook CPU Fans
- Game Station CPU Fans
- ASIC Cooling Fans

3 Description

The DRV10963 is a three phase sensor-less motor driver with integrated power MOSFETs. It is specifically designed for high efficiency, low noise and low external component count motor drive applications. The proprietary sensor-less window-less 180° sinusoidal control scheme offers ultra-quiet motor drive performance. The DRV10963 contains an intelligent lock detect function, combined with other internal protection circuits to ensure safe operation. The DRV10963 is available in a thermally efficient 10-pin USON package with an exposed thermal pad.

Device Information

PART NUMBER	PACKAGE	BODY SIZE (NOM)
DRV10963	USON (10)	3.00 mm x 3.00 mm

(1) For all available packages, see the orderable addendum at the end of the data sheet.

Simplified Schematic

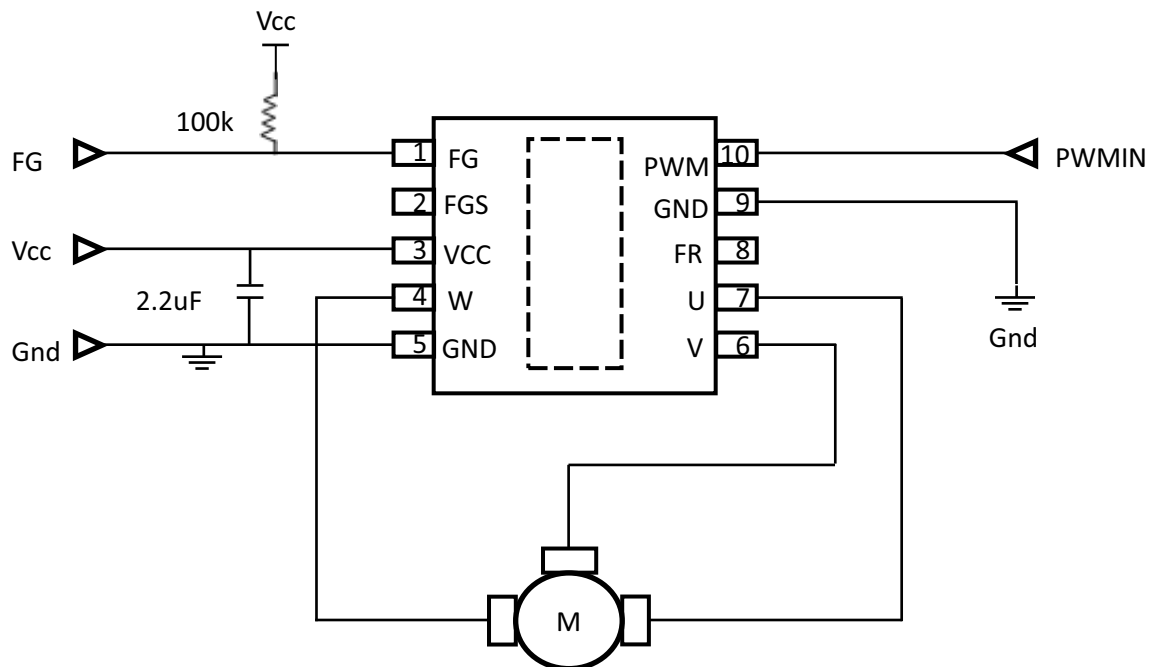

Table of Contents

1 Features	1	7.3 Feature Description.....	8
2 Applications	1	7.4 Device Functional Modes.....	17
3 Description	1	8 Application and Implementation	19
4 Revision History	2	8.1 Application Information.....	19
5 Pin Configuration and Functions	3	8.2 Typical Application	19
6 Specifications	4	9 Power Supply Recommendations	22
6.1 Absolute Maximum Ratings	4	10 Layout	22
6.2 ESD Ratings.....	4	10.1 Layout Guidelines	22
6.3 Recommended Operating Conditions.....	4	10.2 Layout Example	22
6.4 Thermal Information	4	11 Device and Documentation Support	23
6.5 Electrical Characteristics.....	5	11.1 Community Resources.....	23
6.6 Typical Characteristics.....	6	11.2 Trademarks	23
7 Detailed Description	7	11.3 Electrostatic Discharge Caution.....	23
7.1 Overview	7	11.4 Glossary	23
7.2 Functional Block Diagram	7	12 Mechanical, Packaging, and Orderable Information	23

4 Revision History

NOTE: Page numbers for previous revisions may differ from page numbers in the current version.

Changes from Original (March 2013) to Revision A

Page

- Added *ESD Ratings* table, *Feature Description* section, *Device Functional Modes*, *Application and Implementation* section, *Power Supply Recommendations* section, *Layout* section, *Device and Documentation Support* section, and *Mechanical, Packaging, and Orderable Information* section **1**

5 Pin Configuration and Functions

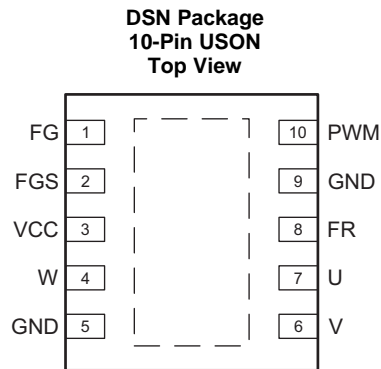

Pin Functions

PIN		I/O	DESCRIPTION
NUMBER	NAME		
1	FG	Output	Motor speed indicator output (open drain)
2	FGS	Input	Motor speed indicator selector. The state of this pin is latched on power up and can not be changed dynamically.
3	VCC	Power	Input voltage for motor and chip supply
4	W	IO	Motor Phase W
5	GND	Ground	Ground
6	V	IO	Motor Phase V
7	U	IO	Motor Phase U
8	FR	Input	Motor direction selector. This pin can be dynamically changed after power up.
9	GND	Ground	Ground
10	PWM	Input	Motor speed control input.
—	Thermal Pad	—	Connect to Ground for maximum thermal efficiency. Thermal pad is on the bottom of the package

6 Specifications

6.1 Absolute Maximum Ratings

over operating free-air temperature range (unless otherwise noted)^{(1) (2)}

		MIN	MAX	UNIT
	VCC Pin supply voltage	-0.3	6	V
	Motor phase pins (U, V, W)	-1	7.7	V
	Direction, speed indicator input, and speed input (FR, FGS, PWM)	-0.3	6	V
	Speed output (FG)	-0.3	7.7	V
T _J	Junction temperature	-40	150	°C
T _{SDR}	Maximum lead soldering temperature, 10 seconds		260	°C
T _{stg}	Storage temperature	-55	150	°C

- (1) Stresses beyond those listed under *Absolute Maximum Ratings* may cause permanent damage to the device. These are stress ratings only, which do not imply functional operation of the device at these or any other conditions beyond those indicated under *Recommended Operating Conditions*. Exposure to absolute-maximum-rated conditions for extended periods may affect device reliability.
- (2) All voltages are with respect to ground.

6.2 ESD Ratings

		VALUE	UNIT
V _(ESD)	Electrostatic discharge		V
	Human-body model (HBM), per ANSI/ESDA/JEDEC JS-001 ⁽¹⁾	±3000	
	Charged-device model (CDM), per JEDEC specification JESD22-C101 ⁽²⁾	±1500	

- (1) JEDEC document JEP155 states that 500-V HBM allows safe manufacturing with a standard ESD control process.
- (2) JEDEC document JEP157 states that 250-V CDM allows safe manufacturing with a standard ESD control process.

6.3 Recommended Operating Conditions

over operating free-air temperature range (unless otherwise noted)

		MIN	MAX	UNIT
VCC	VCC Pin supply voltage	2.1	5.5	V
U, V, W	Motor phase pins	-0.1	7	V
FR, FGS, PWM	Direction, speed indicator input, and speed input	-0.1	5.5	V
FG	Speed output	-0.1	7.5	V
T _J	Junction temperature	-40	125	°C

6.4 Thermal Information

THERMAL METRIC ⁽¹⁾		DRV10963	UNIT
		DSN (USON)	
		10 PINS	
R _{θJA}	Junction-to-ambient thermal resistance	40.9	°C/W
R _{θJC(top)}	Junction-to-case (top) thermal resistance	46.6	°C/W
R _{θJB}	Junction-to-board thermal resistance	15.8	°C/W
ψ _{JT}	Junction-to-top characterization parameter	0.5	°C/W
ψ _{JB}	Junction-to-board characterization parameter	16	°C/W
R _{θJC(bot)}	Junction-to-case (bottom) thermal resistance	2.9	°C/W

- (1) For more information about traditional and new thermal metrics, see the *Semiconductor and IC Package Thermal Metrics* application report, [SPRA953](#).

6.5 Electrical Characteristics

 (V_{CC} = 5 V, T_A = 25°C unless otherwise noted)

PARAMETER		TEST CONDITION	MIN	TYP	MAX	UNIT
SUPPLY CURRENT						
I _{VCC}	Operating current	PWM = V _{CC} , no motor connected		5.5		mA
I _{VCC_SLEEP}	Sleep current	PWM = 0 V		15	20	μA
UVLO						
V _{UVLO_H}	Undervoltage threshold high			2	2.1	V
V _{UVLO_L}	Undervoltage threshold low		1.7	1.8		V
V _{UVLO_HYS}	Undervoltage threshold hysteresis		100	200	300	mV
INTEGRATED MOSFET						
R _{DS(on)}	Series resistance (H+L)	V _{CC} = 5 V; I _{OUT} = 0.5 A		1	1.5	Ω
PWM						
V _{IH_PWM}	Input high threshold		2.3			V
V _{IL_PWM}	Input low threshold				0.8	V
F _{PWM}	PWM input frequency	Duty cycle >0% and <100%	15		100	kHz
R _{PU_PWM_VCC}	PWM pin pullup resistor	Active Mode		50		kΩ
		Standby Mode		2		MΩ
T _{SLEEP}	Sleep entry time	PWM = 0 V		500		μs
FG						
I _{OL_FG}	FG sink current	V _{FG} = 0.3 V	5			mA
I _{SC_FG}	FG short circuit current	V _{FG} = 5 V		13	25	mA
FGS and FR						
V _{IH_FGS}	Input high threshold		2.3			V
V _{IL_FGS}	Input low threshold				0.8	V
V _{IH_FR}	Input high threshold		2.3			V
V _{IL_FR}	Input low threshold				0.8	V
R _{PU_FGS_VCC}	FGS pin pullup resistor	Active Mode		50		kΩ
		Standby Mode		2		MΩ
R _{PU_FR_VCC}	FR pin pullup resistor			500		kΩ
LOCK PROTECTION						
T _{ON_LOCK}	Lock detect time			0.3		s
T _{OFF_LOCK}	Lock release time			5		s
CURRENT LIMIT						
I _{LIMIT}	Soft current limit value			500		mA
SHORT CIRCUIT CURRENT PROTECTION [I_{LIMIT} [2:0] = 4]						
I _{SHT}	Short circuit current protection			1.8		A
THERMAL SHUTDOWN						
T _{SD}	Thermal shutdown temperature			160		°C
T _{SD_HYS}	Thermal shutdown hysteresis			10		°C

6.6 Typical Characteristics

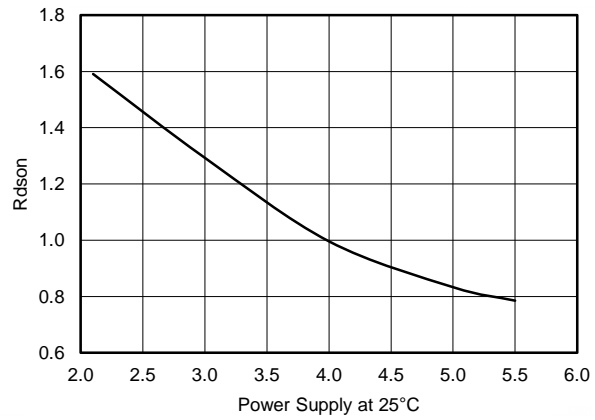

Figure 1. $R_{DS(on)}$ vs Power Supply at 25°C

7 Detailed Description

7.1 Overview

The DRV10963 device is a three phase sensor-less motor driver with integrated power MOSFETs. It is specifically designed for high efficiency, low noise and low external component count motor drive applications. The proprietary sensor-less window-less 180° sinusoidal control scheme provides ultra-quiet motor operation by keeping electrically induced torque ripple small.

Upon start-up, the DRV10963 device will spin the motor in the direction indicated by the FR input pin. The DRV10963 device will operate a three phase BLDC motor using a sinusoidal control scheme. The magnitude of the applied sinusoidal phase voltages is determined by the duty cycle of the PWM pin. As the motor spins, the DRV10963 device provides the speed information at the FG pin.

The DRV10963 device contains an intelligent lock detect function. In the case where the motor is stalled by an external force, the system will detect the lock condition and will take steps to protect itself as well as the motor. The operation of the lock detect circuit is described in detail in [Lock Detection](#).

The DRV10963 device also contains several internal protection circuits such as overcurrent protection, overvoltage protection, undervoltage protection, and overtemperature protection.

7.2 Functional Block Diagram

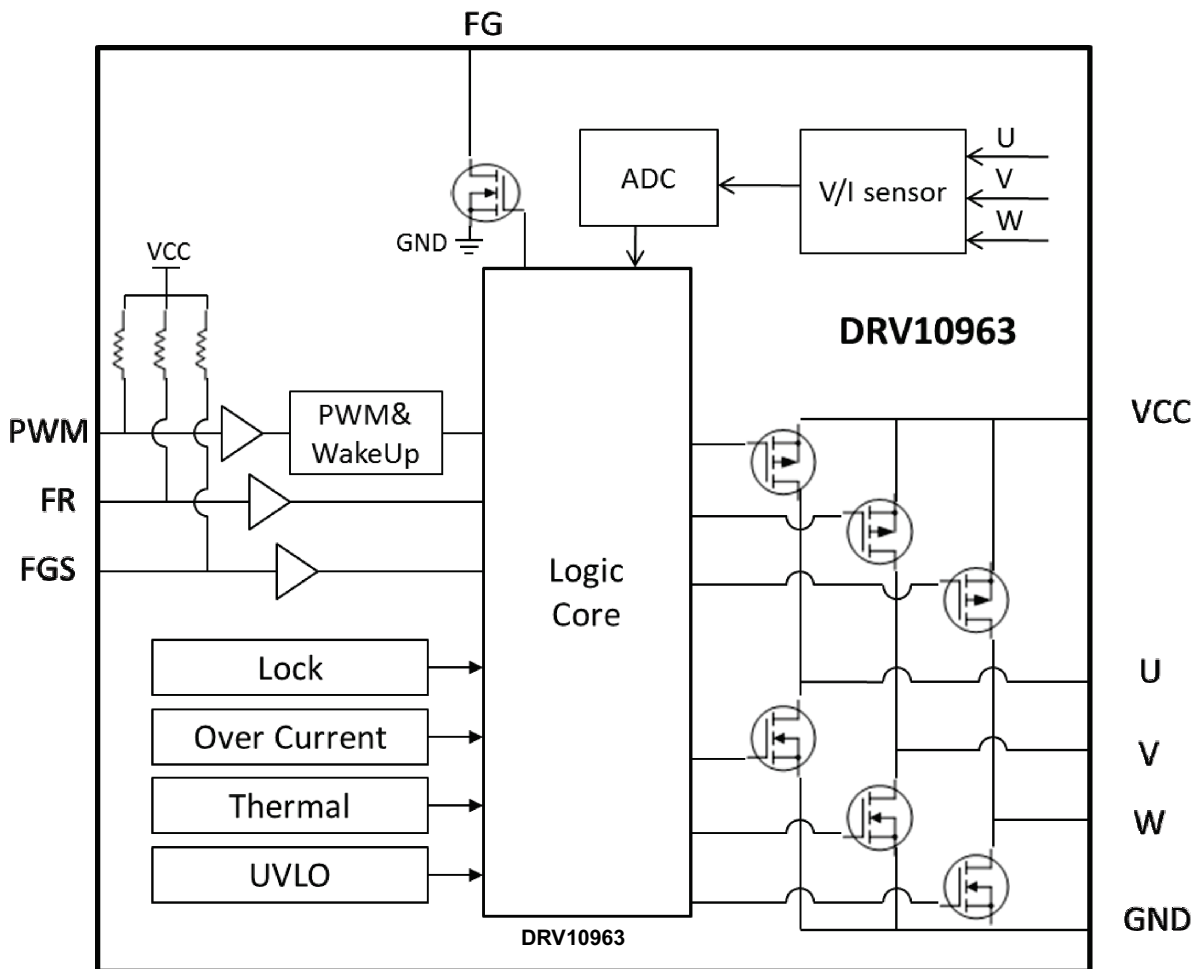

7.3 Feature Description

7.3.1 Speed Input and Control

The DRV10963 provides 3-phase 25-kHz PWM outputs which have an average value of sinusoidal waveforms from phase to phase. When any phase is measured with reference to ground, the waveform observed will be a PWM encoded sinusoid coupled with 3rd order harmonics as shown in Figure 2. This encoding scheme simplifies the driver requirements because there will always be one phase output that is equal to zero.

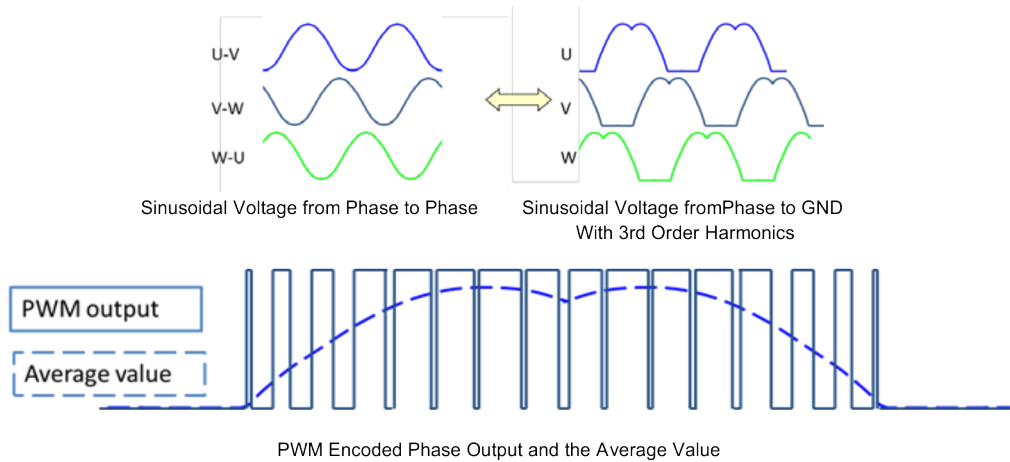

Figure 2. Sinusoidal Phase Encoding Used in DRV10963

The output amplitude is determined by the supply voltage (VCC) and the commanded PWM duty cycle (PWM) as described in Equation 1 and illustrated in Figure 3. The maximum amplitude is applied when the commanded PWM duty cycle is 100%.

$$V_{ph_{pk}} = PWMdc \times VCC \tag{1}$$

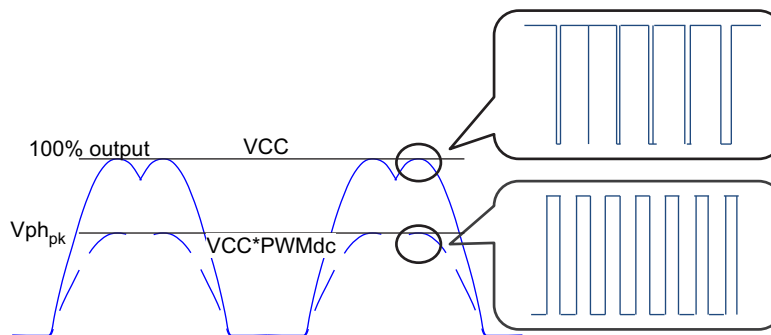

Figure 3. Output Voltage Amplitude Adjustment

The motor speed is controlled indirectly by using the PWM command to control the amplitude of the phase voltages which are applied to the motor.

The duty cycle of PWM input is converted into a 9 bit digital number (from 0 to 511). The control resolution is $1/512 \approx 0.2\%$. The duty cycle analyzer implements a first order transfer function between the input duty cycle and the 9 bits digital number. This is illustrated in Figure 4, where $\tau=80$ ms.

Feature Description (continued)

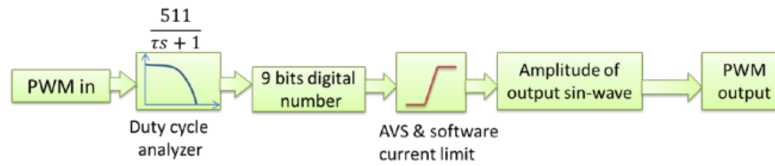

Figure 4. PWM Command Input Controls the Output Peak Amplitude

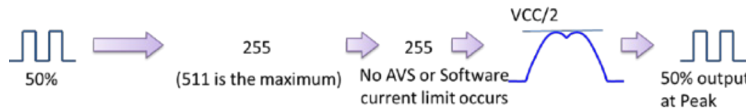

Figure 5. Example of PWM Command Input Controlling the Output

The transfer function between the PWM commanded duty cycle and the output peak amplitude is adjustable in the DRV10963 device. The output peak amplitude is described by Equation 1 when PWMcommand > minimum operation duty cycle. The minimum operation duty cycle can be set to either 13%, 10%, 5% or no limit by OTP setting (MINOP_DC[1:0]). Table 1 shows the optional settings for the minimum operation duty cycle. When the PWM commanded duty cycle is lower than minimum operation duty cycle and higher than 1.5%, the output will be controlled at the minimum operation duty cycle. When the input duty cycle is lower than 1.5%, the DRV10963 device will not drive the output, and enters the standby mode. This is illustrated in Figure 6.

Table 1. Minimum Operation Duty Cycle

MINOP_DC[1:0]	MINIMUM OPERATION DUTY CYCLE
0	0 (no limit)
1	5%
2	10%
3	13%

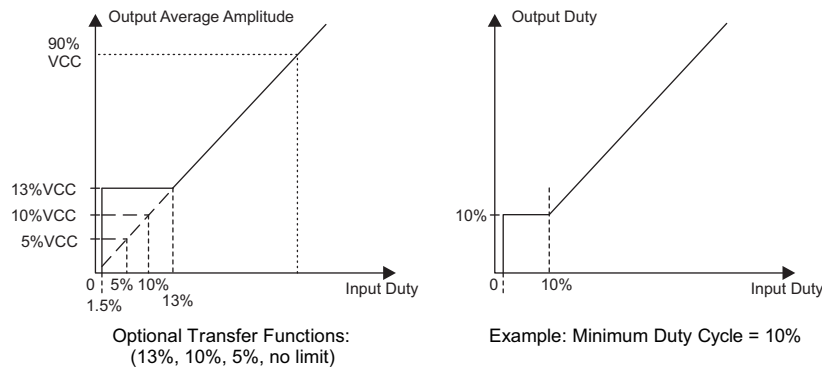

Figure 6. Speed Control Transfer Function

7.3.2 Spin up Settings

DRV10963 starts the motor using a procedure which is illustrated in Figure 7.

The motor start profile includes device configurable options for open loop to close loop transition threshold (H_{Offth}), align time (T_{Align}), and accelerate rate (R_{Acc}).

To align the rotor to the commutation logic the DRV10963 applies an x% duty cycle on phases V and W while holding phase U at GND. This condition is maintained for T_{Align} seconds. The x% value is determined by the VCC voltage (as shown in Table 2) to maintain sufficient driving torque over a wide range of supply voltages.

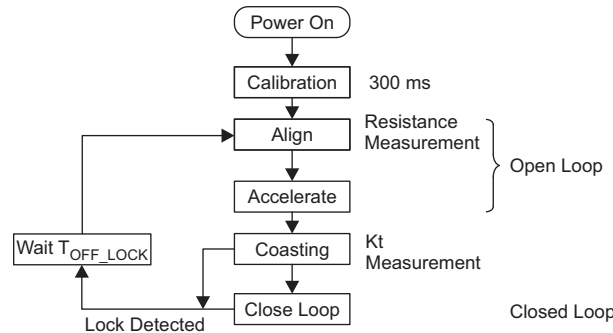

Figure 7. DRV10963 Initialization and Motor Start-up Sequence

Table 2. Align and Open Loop Duty Cycle

VCC VOLTAGE	DUTY CYCLE DURING ALIGN AND OPEN LOOP (X)%
5.25 to approximately 6 V	43%
4.5 to approximately 5.25 V	50%
3.75 to approximately 4.5 V	60%
3 to approximately 3.75 V	75%
<3	100%

When the align phase completes, the motor is accelerated by applying sinusoidal phase voltages with peak magnitudes as illustrated in Table 2 and stepping through the commutation sequence at an increasing rate described by R_{Acc} until the rate of commutation reaches H_{Offth} Hz. When this threshold is reached, the DRV10963 switches to closed loop mode where the commutation drive sequence is determined by the internal control algorithm and the applied voltage is determined by the PWM commanded duty cycle input. The open loop to close loop transition threshold (H_{Offth}), align time (T_{Align}), and the accelerate rate (R_{Acc}) are device configurable through OTP settings (HO_TH[3:0], TARA_TH[3:0]).

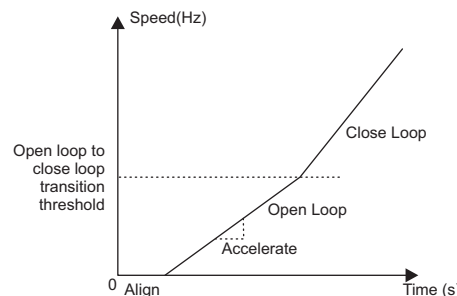

Figure 8. DRV10963 Start-up Profile

The selection of handoff threshold (H_{Offth}) can be determined by experimental testing. The goal is to choose a handoff threshold that is as low as possible and allows the motor to smoothly and reliably transition between the open loop acceleration and the closed loop acceleration. Normally higher speed motors (maximum speed) require a higher handoff threshold because higher speed motors have lower K_t and as a result lower BEMF. Table 3 shows the configurable settings for the handoff threshold. Maximum speed in electrical Hz are shown as a guide to assist in identifying the appropriate handoff speed for a particular application.

Table 3. Motor Handoff Speed Threshold Options

MAXIMUM SPEED (Hz)	H _{Offth} (Hz)	HO_TH [3:0]
<100	12.5	1
100 to approximately 150	25	2
150 to approximately 200	37.5	3
200 to approximately 250	50	4
250 to approximately 300	62.5	5
300 to approximately 350	75	6
350 to approximately 400	87.5	7
400 to approximately 450	100	8
450 to approximately 500	112.5	9
500 to approximately 560	125	A
560 to approximately 620	137.5	B
620 to approximately 700	150	C
700 to approximately 800	162.5	D
800 to approximately 900	175	E
>900	187.5	F

The selection of align time (T_{Align}) and accelerate rate (R_{Acc}) can also be determined by experimental testing. Motors with higher inertia typically require a longer align time and slower accelerate rate while motors with low inertia typically require a shorter align time and a faster accelerate rate. System tradeoffs should be done to optimize start up reliability versus spin up time. TI recommends starting with choosing the less aggressive settings (slow R_{Acc} and large T_{Align}) to sacrifice the spin up time in favor of highest success rate. Once the system is verified to work reliably the more aggressive settings (higher R_{Acc} and smaller T_{Align}) can be used to decrease the spin up time while carefully monitoring the success rate.

Table 4 shows the configurable settings for T_{Align} and R_{Acc} .

Table 4. Motor Alignment and Accelerate Options

T _{Align} (ms)	R _{Acc} (Hz/s)	TARA_TH[3:0]
40	150	1
80	140	2
120	130	3
160	120	4
200	110	5
240	100	6
280	90	7
320	80	8
360	70	9
400	60	A
440	50	B
480	40	C
520	30	D
560	20	E
600	10	F

7.3.3 Motor Direction Change

The DRV10963 can be easily configured to drive the motor in either direction by setting the input on the FR (Forward Reverse) pin to a logic 1 or logic 0 state. The direction of commutation as described by the commutation sequence is illustrated in Table 5.

Table 5. Motor Direction Phase Sequencing

	FR = 10	FR = 01
Motor direction	U->V->W	U->W->V

7.3.4 Motor Frequency Feedback (FG)

During operation of the DRV10963 device, the FG pin provides an indication of the speed of the motor. The output provided on this pin can be configured by use of an OTP setting (FGOPT) and by applying a logic signal to the FGS pin. The configuration of this output is defined in [Table 6](#).

Table 6. FG Motor Status Speed Indicator Configuration

MOTOR CONDITION	(FGS = 1)	FGOPT=1,(FGS = 0)	FGOPT=0,(FGS = 0)
DRV10963xxDSNR Normal Operation	Toggles once per electrical cycle	Toggles once every 2 electrical cycles	Toggles once every 3 electrical cycles

As seen in [Table 6](#), the FG pin can be configured to toggle either once per electrical cycle, once per 2 electrical cycles or once per every 3 electrical cycles. Using this information and the number of pole pairs in the motor, the mechanical speed of the motor can be determined.

The formula to determine the speed of the motor is:

$$\text{If FGS} = 1, \text{RPM} = (\text{FREQFG} \times 60) / \text{number of pole pairs} \tag{2}$$

$$\text{If FGS} = 0, \text{FGOPT} = 1, \text{RPM} = (\text{FREQFG} \times 120) / \text{number of pole pairs} \tag{3}$$

or

$$\text{If FGS} = 0, \text{FGOPT} = 0, \text{RPM} = (\text{FREQFG} \times 180) / \text{number of pole pairs} \tag{4}$$

The FG pin has built in short circuit protection, which limits the current in the event that the pin is shorted to VCC. The current will be limited to I_{SC_FG} .

7.3.5 Lock Detection

When the motor is locked by some external condition the DRV10963 will detect the lock condition and will take action to protect the motor and the device. The lock condition must be properly detected whether it occurs as a result of a slowly increasing load or a sudden shock.

The DRV10963 reacts to lock conditions by stopping the motor drive. To stop driving the motor the phase outputs are placed into a high impedance state. To prevent the current which is flowing in the motor from being returned to the power supply (VCC) the DRV10963 uses an **ANTI VOLTAGE SURGE** feature. This feature is described in a following section. After successfully transitioning into a high impedance state as the result of a lock condition the DRV10963 will attempt to restart the motor after T_{OFF_LOCK} seconds.

The DRV10963 has a comprehensive lock detect function which includes 5 different lock detect schemes. Each of these schemes detects a particular condition of lock as illustrated in [Figure 9](#).

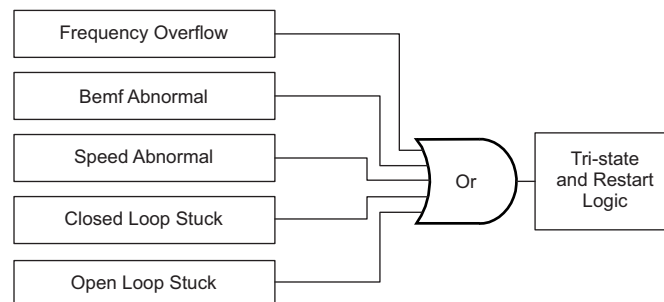

Figure 9. Lock Detect

The behavior of each lock detect scheme is described in the following sections.

7.3.5.1 Lock1: Frequency Overflow

For most applications the maximum electrical frequency of the motor will be less than 3 kHz. If the motor is stopped then the BEMF voltage will be zero. Under this condition, when the DRV10963 device is in the closed loop mode, the sensor less control algorithm will continue to accelerate the electrical commutation rate even though the motor is not spinning. A lock condition is triggered if the electrical frequency exceeds 3 kHz.

7.3.5.2 Lock2: BEMF Abnormal

For any specific motor, the integrated value of BEMF during half of an electronic cycle will be a constant as illustrated by the shaded green area in Figure 10. This is true regardless of whether the motor runs fast or slow. The DRV10963 monitors this value and uses it as a criterion to determine if the motor is in a lock condition.

The DRV10963 uses the integrated BEMF to determine the K_t value of the motor during the initial motor start. Based on this measurement a range of acceptable K_t values is established. This range is referred to as K_{t_low} and K_{t_high} . During closed loop motor operation the K_{tc} value is continuously updated. If the calculated K_{tc} goes beyond the acceptable range a lock condition is triggered. This is illustrated in Figure 11.

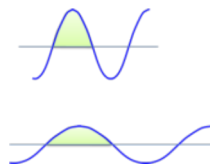

Figure 10. BEMF Integration

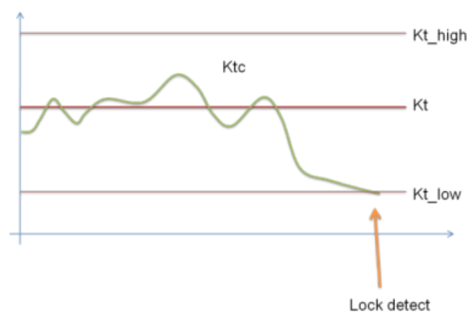

Figure 11. Abnormal K_t Lock Detect

7.3.5.3 Lock3: Speed Abnormal

If the motor is in normal operation the motor BEMF will always be less than the voltage applied to the phase. The DRV10963 sensorless control algorithm is continuously updating the value of the motor BEMF based on the speed of the motor and the motor K_t as shown in Figure 12. If the calculated value for motor BEMF is higher than the applied voltage (U) for a certain period of time (TON_LOCK) then there is an error in the system. The calculated value for motor BEMF is wrong or the motor is out of phase with the commutation logic. When this condition is detected a lock detect is triggered.

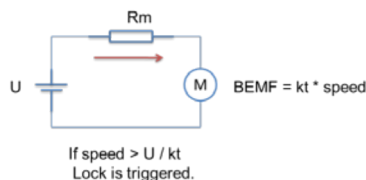

Figure 12. BEMF Monitoring

7.3.5.4 Open Loop Stuck

This lock condition is active when the DRV10963 device is operating in the open loop mode. When the open loop commutation rate becomes higher than the open to closed loop threshold (H_{Offth} - see Figure 8) and the zero cross is not detected for the time corresponding to 2 electrical cycles then this is an indication that the motor is not moving. Under this condition the open loop stuck lock condition will be triggered.

7.3.6 Soft Current Limit

The current limit function provides active protection for preventing damage as a result of high current. The soft current limit does not use direct current measurement for protection, but rather, uses the measured motor resistance (R_m) and motor velocity constant (K_t) to limit the voltage applied to the phase (U) such that the current does not exceed the limit value (I_{LIMIT}). This is illustrated in Figure 13 based on the calculation shown in Equation 5.

The soft limit is only active when in normal closed loop mode and does not result in a fault condition nor does it result in the motor being stopped. The soft current limit is typically useful for limiting the current that results from heavy loading during motor acceleration.

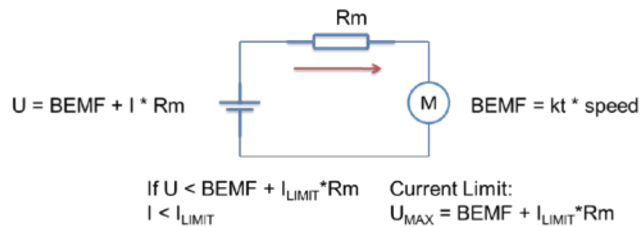

Figure 13. Current Limit

$$U_{LIMIT} = I_{LIMIT} \times R_m + Speed \times K_t \tag{5}$$

I_{LIMIT} is configured by OTP setting (ILIMIT [2:0]) according to Table 7.

NOTE

The soft current limit calculation is not correct if the motor is out of phase with the commutation control logic (locked rotor). The soft current limit will not be effective under this condition.

Table 7. I_{LIMIT} Settings

I_{LIMIT} [2:0]	I_{LIMIT}
0	No current limit
1	125 mA
2	250 mA
3	375 mA
4	500 mA
5	625 mA
6	750 mA
7	875 mA

7.3.7 Short Circuit Current Protection

The short circuit current protection function shuts off drive to the motor by placing the motor phases into a high impedance state if the current in any motor phase exceeds the short circuit protection limit I_{SHT} . The DRV10963 device will go through the initialization sequence and will attempt to restart the motor after the short circuit condition is removed. This function is intended to protect the device and the motor from catastrophic failure when subjected to a short circuit condition.

7.3.8 Anti-Voltage Surge (AVS)

Under normal operation the DRV10963 acts to transfer energy from the power supply to the motor to generate torque, which results in angular rotation of the motor. Under certain conditions, however, energy which is stored in the motor in the form of inductive energy or angular momentum (mechanical energy) can be returned to the power supply. This can happen whenever the output voltage is quickly interrupted or whenever the voltage applied to the motor becomes less than the BEMF voltage generated by the motor. The energy which is returned to the supply can cause the supply voltage to increase. This condition is referred to as voltage surge.

The DRV10963 includes an anti-voltage-surge (AVS) feature which prevents energy from being transferred from the motor to the power supply. This feature helps to protect the DRV10963 as well as any other components that are connected to the power supply (VCC).

7.3.8.1 Protecting Against the Return of Mechanical Energy

Mechanical energy is typically returned to the power supply when the speed command is abruptly decreased. If the voltage applied to the phase becomes less than the BEMF voltage then the motor will work as a generator and current will flow from the motor back to VCC. This is illustrated in Figure 14. To prevent this from happening, the DRV10963 buffers the speed command value and limits the rate at which it is able to change. The AVS function acts to ensure that the effective output amplitude (U) is maintained to be larger than the BEMF voltage. This prevents current from becoming less than zero. The value of BEMF used to perform this function is calculated by the motor Kt and the motor speed.

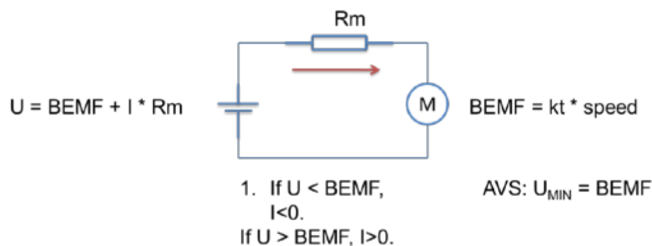

Figure 14. Mechanical AVS

7.3.8.2 Protecting Against the Return of Inductive Energy

When the DRV10963 suddenly stops driving the motor, the current which is flowing in the motor's inductance will continue to flow. It flows through the intrinsic body diodes in the mosfets and charges VCC. An example of this behavior is illustrated by the two pictures in the top half of Figure 15. When the driver is active, the current flows from S1 to the motor and then to S6 and is returned to ground. When the driver is placed into a high impedance (tri-state) mode, the current goes flows from ground through the body diode of S2 to the motor and then through the body diode of S5 to VCC. The current will continue to flow through the motor's inductance in this direction until the inductive energy is dissipated.

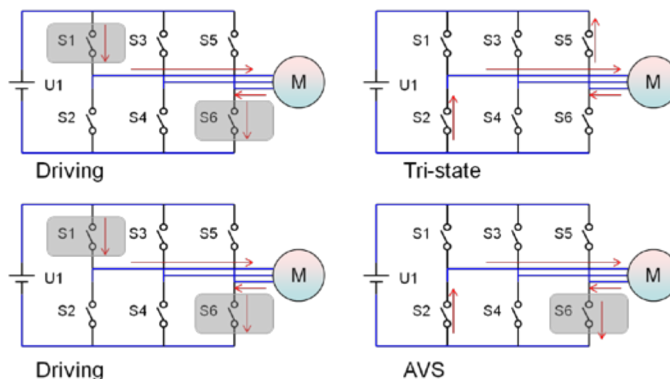

Figure 15. Inductive AVS

The lower two pictures in Figure 14 illustrate how the AVS circuit in the DRV10963 device prevents this energy from being returned to the supply. When the AVS condition is detected the DRV10963 device will act to turn on the low side device designated as S6. This allows the current flowing in the motor inductance to be returned to ground instead of being directed to the VCC supply voltage.

7.3.9 Control Advance Angle

To achieve the best efficiency it is often desirable to control the drive state of the motor so that the motor's phase current is aligned with the motor's BEMF voltage.

To align the motor's phase current with the motor's BEMF voltage the inductive effect of the motor must be considered. The voltage applied to the motor should be applied in advance of the motor's BEMF voltage. This is illustrated in Figure 16. The DRV10963 provides configuration bits (CTRL_ANG[4:0]) for controlling the time (Tadv) between the driving voltage and BEMF. For motors with salient pole structures, aligning the motor BEMF voltage with the motor current may not achieve the best efficiency. In these applications the timing advance should be adjusted accordingly. This can be accomplished by operating the system at constant speed and load conditions and by adjusting the Tadv until the minimum current is achieved.

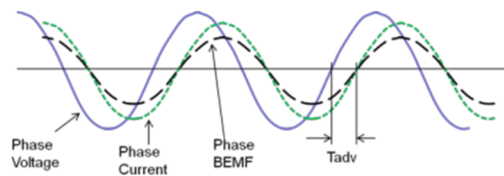

Figure 16. DRV10963 Advance Angle Control

Table 8. Control Advance Angle Settings

CTRL_ANG[4:0]	Tadv
0	0
1	20 μ s
2	40 μ s
3	60 μ s
n	n \times 20 μ s
6	120 μ s
8	160 μ s
31	620 μ s

7.3.10 Overtemperature Protection

The DRV10963 contains a thermal shut down function which disables motor operation when the device junction temperature has exceeded T_{SD} . Motor operation will resume when the junction temperature becomes lower than $T_{SD} - T_{SD_HYS}$.

7.3.11 Undervoltage Protection

The DRV10963 contains an undervoltage lockout feature, which prevents motor operation whenever the supply voltage (VCC) becomes too low. Upon power up, the DRV10963 will operate once VCC rises above V_{UVLO_H} . The DRV10963 will continue to operate until VCC falls below V_{UVLO_L} .

7.3.12 OTP Configuration

The DRV10963 features OTP (one time programmable) bits to allow for flexible configuration of the device in order for optimization over a wide range of applications. Selection of various OTP options is described throughout this specification. The DRV10963JJ, DRV10963JM, DRV10963JU, and DRV10963JA parts listed in Table 10 are configured at the factory based on popular OTP settings for several different applications. TI provides EVM hardware along with a special GUI and a Motor System Tuning Guide which provides detailed instructions for determining the right part for your application. If your application requires settings not provided in

any of the DRV10963Jx parts then the DRV10963P part can be used. The DRV10963P part provides blank OTP settings that can be configured for optimal performance in your application. The TI provided EVM and GUI will allow you to configure the OTP settings. Consult your TI representative if your application requires settings that are not available in the DRV10963Jx configurations described and if you are unable to use the DRV10963P option. The OTP bits used to configure the various part revisions are shown for reference in [Table 10](#).

Table 9. OTP Configuration Bits

OTP BIT NAMES	DESCRIPTION	REFERENCE TO
MINOP_DC[1:0]	Minimum operational duty cycle	Figure 6
SLEEP_EN	Sleep mode enable	Standby Mode and Sleep Mode
TARA_TH[3:0]	Start-up time and accelerate setting	Spin up Settings
HO_TH[3:0]	Openloop to closed loop threshold.	Spin up Settings
ILIMIT[2:0]	Current limit setting.	Table 7
CTRL_ANG[4:0]	Control advance angle.	Table 8
FGOPT	FG output option.	Motor Frequency Feedback (FG)

Table 10. The OTP Setting of the Factory Configured Parts

	MINOP_DC [1:0]	SLEEP_EN	TARA_TH [3:0]	HO_TH [3:0]	ILIMIT [2:0]	CTRL_ANG [4:0]	FGOPT
DRV10963JJ	2	1	7	8	4	6	0
DRV10963JM	2	1	E	4	4	6	1
DRV10963JU	2	1	C	7	4	6	0
DRV10963JA	2	1	7	8	4	8	0
DRV10963P	0	0	0	0	0	0	0

7.4 Device Functional Modes

7.4.1 Standby Mode and Sleep Mode

When the PWM commanded duty cycle input is lower than 1.5%, the phase outputs will be put into a high impedance state. The device will stop driving the motor. The device logic is still active during standby mode and the DRV10963 device will consume current as specified by I_{VCC} .

When the PWM commanded duty cycle input is driven to 0% (less than V_{IL_PWM} for at least T_{SLEEP} time), the DRV10963 device will enter a low power sleep mode. In sleep mode, most of the circuitry in the device will be disabled to minimize the system current. The current consumption in this state is specified by I_{VCC_SLEEP} .

The device will remain in sleep mode until either the PWM commanded duty cycle input is driven to a logic high (higher than V_{IH_PWM}) or the PWM input pin is allowed to float. If the input is allowed to float an internal pullup resistor will raise the voltage to a logic high level.

Recovering from sleep mode is treated the same as power on condition as illustrated in [Figure 7](#).

As part of the device initialization the motor resistance value and the motor Kt value are measured during the initial motor spin up as shown in [Figure 7](#). Whenever the part is executing the initialization sequence it is important to note that the values determined by any previous spin up cycles no longer exist. In order for the motor resistance value and the motor Kt value to be properly initialized the system should be allowed to come to a complete stop before the next restart attempt.

Device Functional Modes (continued)

Sleep mode can be disabled by OTP setting (SLEEP_EN). In this condition, the motor resistance value and the motor Kt value are preserved and the motor can reliably spin up without coming to a complete stop. This feature is referred to as the 're-synchronize' function. If the 're-synchronize' function is required the sleep mode cannot be used.

8 Application and Implementation

NOTE

Information in the following applications sections is not part of the TI component specification, and TI does not warrant its accuracy or completeness. TI's customers are responsible for determining suitability of components for their purposes. Customers should validate and test their design implementation to confirm system functionality.

8.1 Application Information

DRV10963 is used in sensorless 3-phase BLDC motor control. The driver provides a high performance, high reliability, flexible and simple solution for compute fan applications. The following design shows a common application of the DRV10963.

8.2 Typical Application

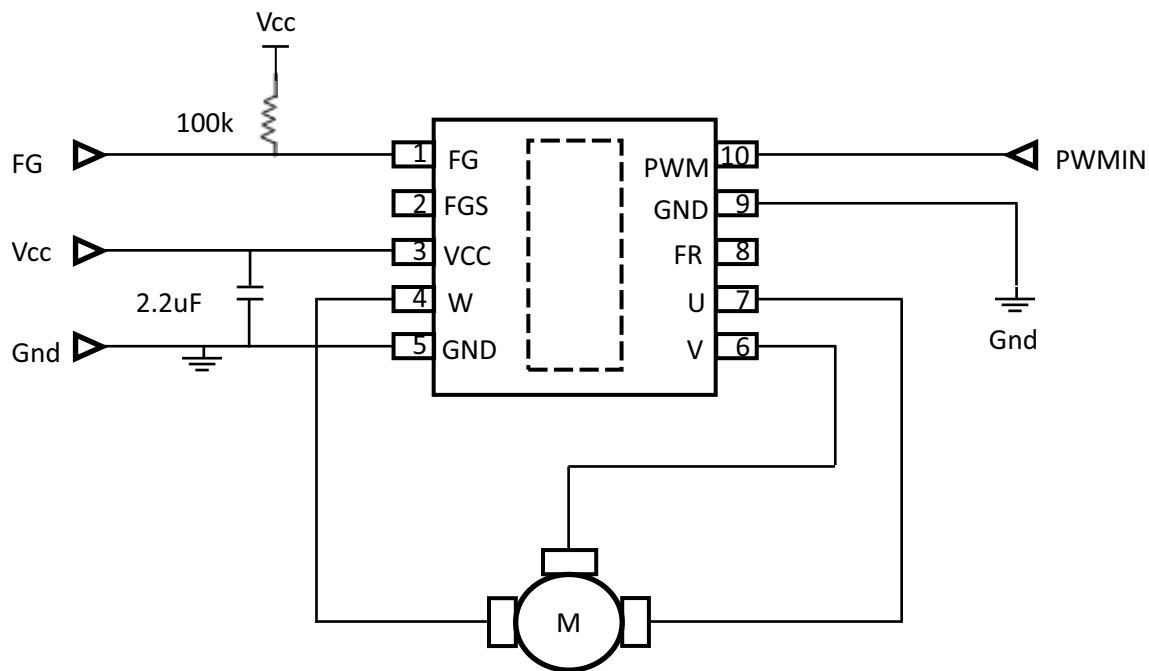

Figure 17. Typical Application Schematic

8.2.1 Design Requirements

Table 11 lists several key motor characteristics and recommended ranges which the DRV10963 is capable of driving. However, that does not necessarily mean motors outside these boundaries cannot be driven by DRV10963.

Recommended ranges listed in Table 11 can serve as a general guideline to quickly decide whether DRV10963 is a good fit for an application. Motor performance is not ensured for all uses.

Table 11. Key Motor Characteristics and Recommended Ranges

	Rm (Ω)	Lm (μ H)	Kt (mV/Hz)	f _{FG_max} (Hz)
Recommended Value	2.5 ~ 36	50 ~ 10000	1 ~ 100	1300

Rm - Motor phase resistance between phase to phase;

Lm - Motor phase to phase inductance between phase to phase;

Kt - Motor BEMF constant from phase to center tape;

f_{FG_max} - Maximum electrical frequency. Maximum motor speed can be calculated from:

- If FGS = 1, RPM = (f_{FG_max} × 60)/ number of pole pairs
- If FGS = 0, RPM = (f_{FG_max} × 120)/ number of pole pairs

8.2.2 Detailed Design Procedure

1. Refer to [Design Requirements](#) and make sure your system meets the recommended application range.
2. Refer to the DRV10963 Tuning Guide and measure the motor parameters.
3. Refer to the DRV10963 Tuning Guide. Configure the parameters using DRV10963 GUI, and optimize the motor operation. The Tuning Guide takes the user through all the configurations step by step, including: start-up operation, closed-loop operation, current control, initial positioning, lock detection, and anti-voltage surge.
4. Build your hardware based on Layout Guidelines.
5. Connect the device into system and validate your system solution

8.2.3 Application Curves

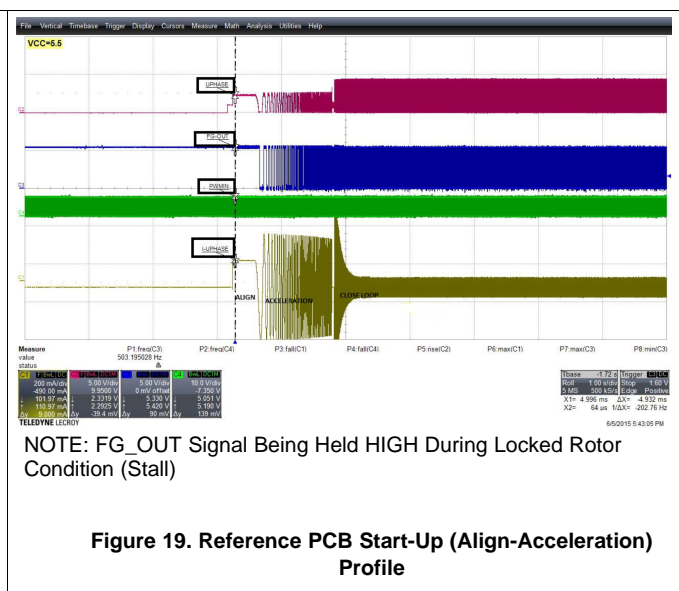
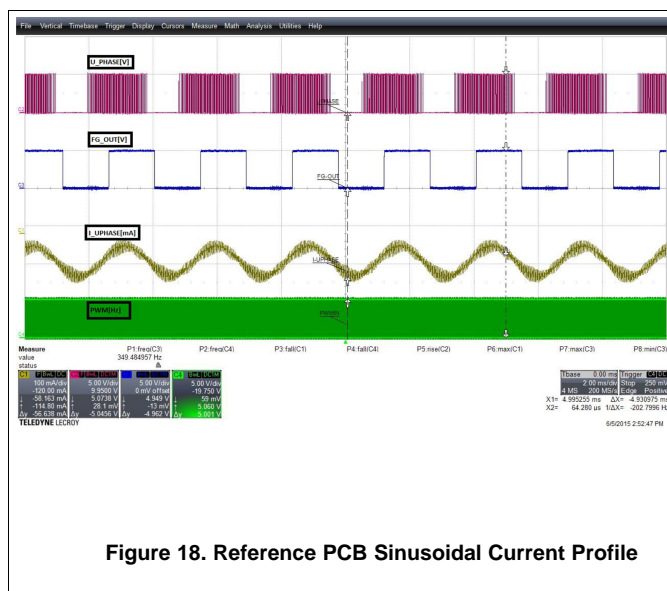

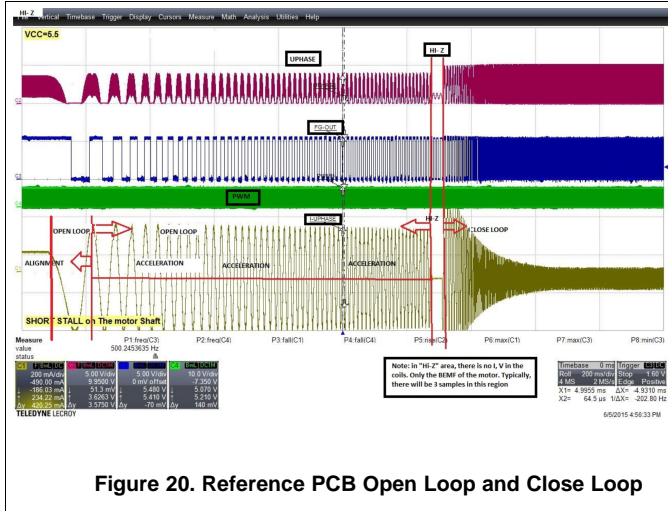

Figure 20. Reference PCB Open Loop and Close Loop

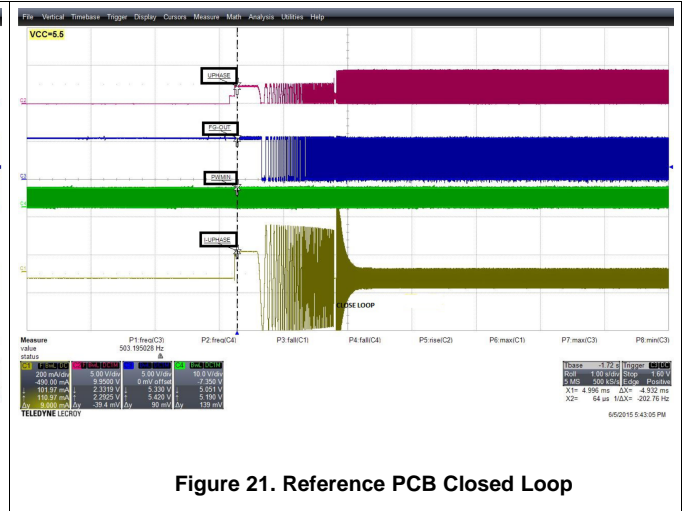

Figure 21. Reference PCB Closed Loop

9 Power Supply Recommendations

The DRV10963 is designed to operate from an input voltage supply, V(VCC), range from 2.1 and 5.5 V. The user must place a 2.2- μ F ceramic capacitor rated for VCC as close as possible to the VCC and GND pin.

10 Layout

10.1 Layout Guidelines

The package uses an exposed pad to remove heat from the device. For proper operation, this pad must be thermally connected to copper on the PCB to dissipate heat. On a multi-layer PCB with a ground plane, this can be accomplished by adding a number of vias to connect the thermal pad to the ground plane. On PCBs without internal planes, copper area can be added on either side of the PCB to dissipate heat. If the copper area is on the opposite side of the PCB from the device, thermal vias are used to transfer the heat between top and bottom layers.

For details about how to design the PCB, refer to TI application report, *PowerPAD™ Thermally Enhanced Package (SLMA002)*, and TI application brief, *PowerPAD™ Made Easy (SLMA004)*, available at www.ti.com. In general, the more copper area that can be provided, the more power can be dissipated.

10.2 Layout Example

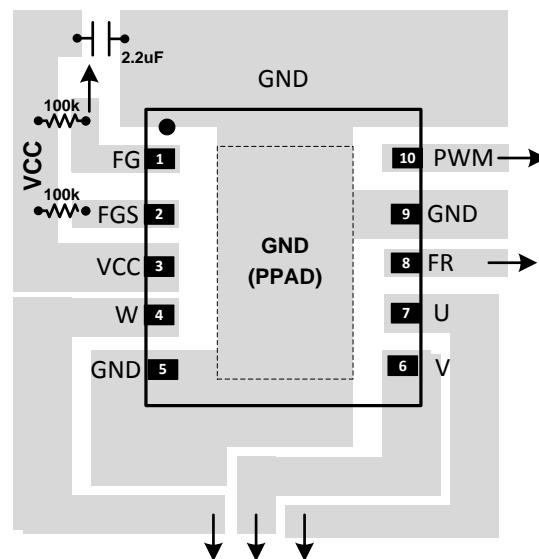

Figure 22. DRV10963 Layout Example

11 Device and Documentation Support

11.1 Community Resources

The following links connect to TI community resources. Linked contents are provided "AS IS" by the respective contributors. They do not constitute TI specifications and do not necessarily reflect TI's views; see TI's [Terms of Use](#).

TI E2E™ Online Community *TI's Engineer-to-Engineer (E2E) Community*. Created to foster collaboration among engineers. At e2e.ti.com, you can ask questions, share knowledge, explore ideas and help solve problems with fellow engineers.

Design Support *TI's Design Support* Quickly find helpful E2E forums along with design support tools and contact information for technical support.

11.2 Trademarks

E2E is a trademark of Texas Instruments.
All other trademarks are the property of their respective owners.

11.3 Electrostatic Discharge Caution



These devices have limited built-in ESD protection. The leads should be shorted together or the device placed in conductive foam during storage or handling to prevent electrostatic damage to the MOS gates.

11.4 Glossary

[SLYZ022](#) — *TI Glossary*.

This glossary lists and explains terms, acronyms, and definitions.

12 Mechanical, Packaging, and Orderable Information

The following pages include mechanical packaging and orderable information. This information is the most current data available for the designated devices. This data is subject to change without notice and revision of this document. For browser-based versions of this data sheet, refer to the left-hand navigation.

PACKAGING INFORMATION

Orderable Device	Status (1)	Package Type	Package Drawing	Pins	Package Qty	Eco Plan (2)	Lead/Ball Finish (6)	MSL Peak Temp (3)	Op Temp (°C)	Device Marking (4/5)	Samples
DRV10963DSNR	ACTIVE	SON	DSN	10	3000	Green (RoHS & no Sb/Br)	CU NIPDAU	Level-2-260C-1 YEAR	-40 to 125	10963B	Samples
DRV10963JADSNR	ACTIVE	SON	DSN	10	3000	Green (RoHS & no Sb/Br)	CU NIPDAU	Level-2-260C-1 YEAR	-40 to 125	963JA	Samples
DRV10963JADSNT	ACTIVE	SON	DSN	10	250	Green (RoHS & no Sb/Br)	CU NIPDAU	Level-2-260C-1 YEAR	-40 to 125	963JA	Samples
DRV10963JJDSNR	ACTIVE	SON	DSN	10	3000	Green (RoHS & no Sb/Br)	CU NIPDAU	Level-2-260C-1 YEAR	-40 to 125	963JJ	Samples
DRV10963JJDSNT	ACTIVE	SON	DSN	10	250	Green (RoHS & no Sb/Br)	CU NIPDAU	Level-2-260C-1 YEAR	-40 to 125	963JJ	Samples
DRV10963JMDSNR	ACTIVE	SON	DSN	10	3000	Green (RoHS & no Sb/Br)	CU NIPDAU	Level-2-260C-1 YEAR	-40 to 125	963JM	Samples
DRV10963JMDSNT	ACTIVE	SON	DSN	10	250	Green (RoHS & no Sb/Br)	CU NIPDAU	Level-2-260C-1 YEAR	-40 to 125	963JM	Samples
DRV10963JUDSNR	ACTIVE	SON	DSN	10	3000	Green (RoHS & no Sb/Br)	CU NIPDAU	Level-2-260C-1 YEAR	-40 to 125	963JU	Samples
DRV10963JUDSNT	ACTIVE	SON	DSN	10	250	Green (RoHS & no Sb/Br)	CU NIPDAU	Level-2-260C-1 YEAR	-40 to 125	963JU	Samples
DRV10963PDSNR	ACTIVE	SON	DSN	10	3000	Green (RoHS & no Sb/Br)	CU NIPDAU	Level-2-260C-1 YEAR	-40 to 125	963P	Samples
DRV10963PDSNT	ACTIVE	SON	DSN	10	250	Green (RoHS & no Sb/Br)	CU NIPDAU	Level-2-260C-1 YEAR	-40 to 125	963P	Samples

(1) The marketing status values are defined as follows:

ACTIVE: Product device recommended for new designs.

LIFEBUY: TI has announced that the device will be discontinued, and a lifetime-buy period is in effect.

NRND: Not recommended for new designs. Device is in production to support existing customers, but TI does not recommend using this part in a new design.

PREVIEW: Device has been announced but is not in production. Samples may or may not be available.

OBSOLETE: TI has discontinued the production of the device.

(2) **RoHS:** TI defines "RoHS" to mean semiconductor products that are compliant with the current EU RoHS requirements for all 10 RoHS substances, including the requirement that RoHS substance do not exceed 0.1% by weight in homogeneous materials. Where designed to be soldered at high temperatures, "RoHS" products are suitable for use in specified lead-free processes. TI may reference these types of products as "Pb-Free".

RoHS Exempt: TI defines "RoHS Exempt" to mean products that contain lead but are compliant with EU RoHS pursuant to a specific EU RoHS exemption.

Green: TI defines "Green" to mean the content of Chlorine (Cl) and Bromine (Br) based flame retardants meet JS709B low halogen requirements of <=1000ppm threshold. Antimony trioxide based flame retardants must also meet the <=1000ppm threshold requirement.

- (3) MSL, Peak Temp. - The Moisture Sensitivity Level rating according to the JEDEC industry standard classifications, and peak solder temperature.
- (4) There may be additional marking, which relates to the logo, the lot trace code information, or the environmental category on the device.
- (5) Multiple Device Markings will be inside parentheses. Only one Device Marking contained in parentheses and separated by a "~" will appear on a device. If a line is indented then it is a continuation of the previous line and the two combined represent the entire Device Marking for that device.
- (6) Lead/Ball Finish - Orderable Devices may have multiple material finish options. Finish options are separated by a vertical ruled line. Lead/Ball Finish values may wrap to two lines if the finish value exceeds the maximum column width.

Important Information and Disclaimer:The information provided on this page represents TI's knowledge and belief as of the date that it is provided. TI bases its knowledge and belief on information provided by third parties, and makes no representation or warranty as to the accuracy of such information. Efforts are underway to better integrate information from third parties. TI has taken and continues to take reasonable steps to provide representative and accurate information but may not have conducted destructive testing or chemical analysis on incoming materials and chemicals. TI and TI suppliers consider certain information to be proprietary, and thus CAS numbers and other limited information may not be available for release.

In no event shall TI's liability arising out of such information exceed the total purchase price of the TI part(s) at issue in this document sold by TI to Customer on an annual basis.

TAPE AND REEL INFORMATION



QUADRANT ASSIGNMENTS FOR PIN 1 ORIENTATION IN TAPE



*All dimensions are nominal

Device	Package Type	Package Drawing	Pins	SPQ	Reel Diameter (mm)	Reel Width W1 (mm)	A0 (mm)	B0 (mm)	K0 (mm)	P1 (mm)	W (mm)	Pin1 Quadrant
DRV10963DSNR	SON	DSN	10	3000	330.0	12.4	3.3	3.3	0.8	8.0	12.0	Q2
DRV10963JADSNR	SON	DSN	10	3000	330.0	12.4	3.3	3.3	0.8	8.0	12.0	Q2
DRV10963JADSNT	SON	DSN	10	250	180.0	12.4	3.3	3.3	0.8	8.0	12.0	Q2
DRV10963JJDSNR	SON	DSN	10	3000	330.0	12.4	3.3	3.3	0.8	8.0	12.0	Q2
DRV10963JJDSNT	SON	DSN	10	250	180.0	12.4	3.3	3.3	0.8	8.0	12.0	Q2
DRV10963JMDSNR	SON	DSN	10	3000	330.0	12.4	3.3	3.3	0.8	8.0	12.0	Q2
DRV10963JMDSNT	SON	DSN	10	250	180.0	12.4	3.3	3.3	0.8	8.0	12.0	Q2
DRV10963JUDSNR	SON	DSN	10	3000	330.0	12.4	3.3	3.3	0.8	8.0	12.0	Q2
DRV10963JUDSNT	SON	DSN	10	250	180.0	12.4	3.3	3.3	0.8	8.0	12.0	Q2
DRV10963PDSNR	SON	DSN	10	3000	330.0	12.4	3.3	3.3	0.8	8.0	12.0	Q2
DRV10963PDSNT	SON	DSN	10	250	180.0	12.4	3.3	3.3	0.8	8.0	12.0	Q2

TAPE AND REEL BOX DIMENSIONS

*All dimensions are nominal

Device	Package Type	Package Drawing	Pins	SPQ	Length (mm)	Width (mm)	Height (mm)
DRV10963DSNR	SON	DSN	10	3000	367.0	367.0	35.0
DRV10963JADSNR	SON	DSN	10	3000	367.0	367.0	35.0
DRV10963JADSNT	SON	DSN	10	250	210.0	185.0	35.0
DRV10963JJDSNR	SON	DSN	10	3000	367.0	367.0	35.0
DRV10963JJDSNT	SON	DSN	10	250	210.0	185.0	35.0
DRV10963JMDSNR	SON	DSN	10	3000	367.0	367.0	35.0
DRV10963JMDSNT	SON	DSN	10	250	210.0	185.0	35.0
DRV10963JUDSNR	SON	DSN	10	3000	367.0	367.0	35.0
DRV10963JUDSNT	SON	DSN	10	250	210.0	185.0	35.0
DRV10963PDSNR	SON	DSN	10	3000	367.0	367.0	35.0
DRV10963PDSNT	SON	DSN	10	250	210.0	185.0	35.0

DSN (S-PUSON-N10)

PLASTIC QUAD FLATPACK NO-LEAD

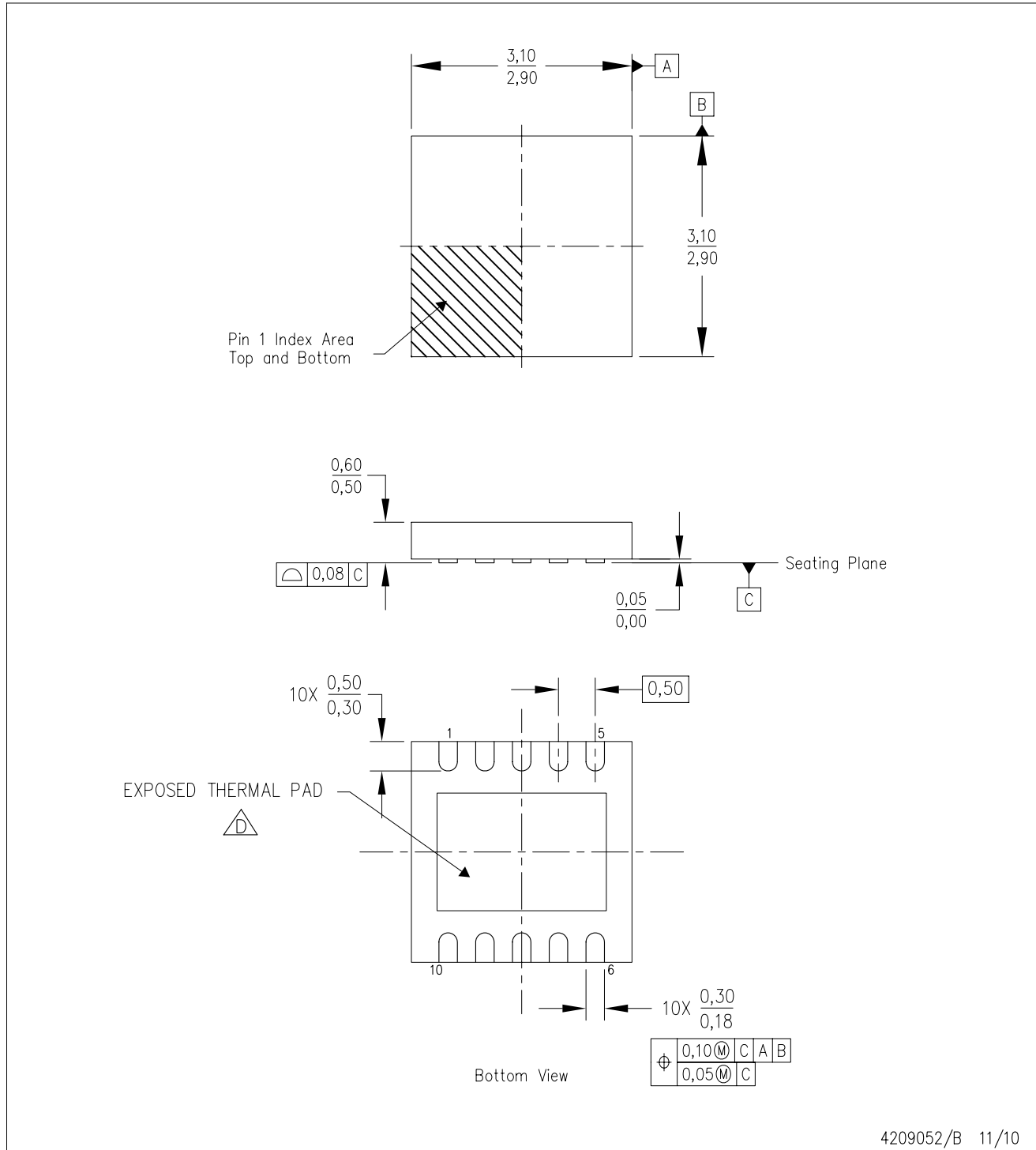

4209052/B 11/10

- NOTES:
- A. All linear dimensions are in millimeters. Dimensioning and tolerancing per ASME Y14.5-1994.
 - B. This drawing is subject to change without notice.
 - C. QFN (Quad Flatpack No-Lead) package configuration.
 -  The package thermal pad must be soldered to the board for thermal and mechanical performance. See the Product Data Sheet for details regarding the exposed thermal pad dimensions.

THERMAL PAD MECHANICAL DATA

DSN (S-PDSO-N10)

PLASTIC QUAD FLATPACK NO-LEAD

THERMAL INFORMATION

This package incorporates an exposed thermal pad that is designed to be attached directly to an external heatsink. The thermal pad must be soldered directly to the printed circuit board (PCB). After soldering, the PCB can be used as a heatsink. In addition, through the use of thermal vias, the thermal pad can be attached directly to the appropriate copper plane shown in the electrical schematic for the device, or alternatively, can be attached to a special heatsink structure designed into the PCB. This design optimizes the heat transfer from the integrated circuit (IC).

For information on the Quad Flatpack No-Lead (QFN) package and its advantages, refer to Application Report, QFN/SON PCB Attachment, Texas Instruments Literature No. SLUA271. This document is available at www.ti.com.

The exposed thermal pad dimensions for this package are shown in the following illustration.

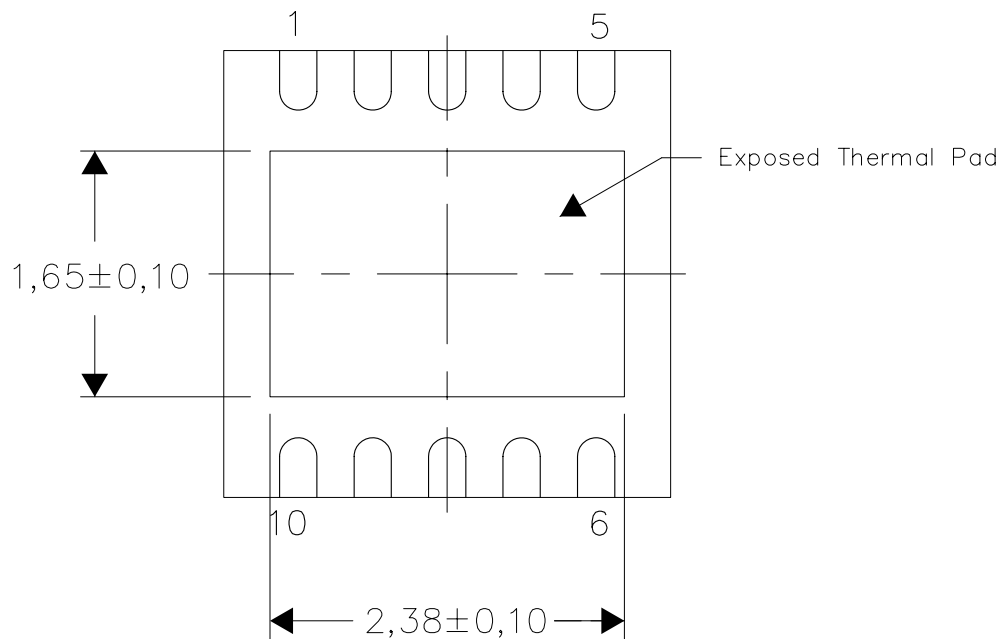

Bottom View

Exposed Thermal Pad Dimensions

4209076-3/D 04/11

NOTES:

- A. All linear dimensions are in millimeters

DSN (S-PUSON-N10)

PLASTIC SMALL OUTLINE NO-LEAD

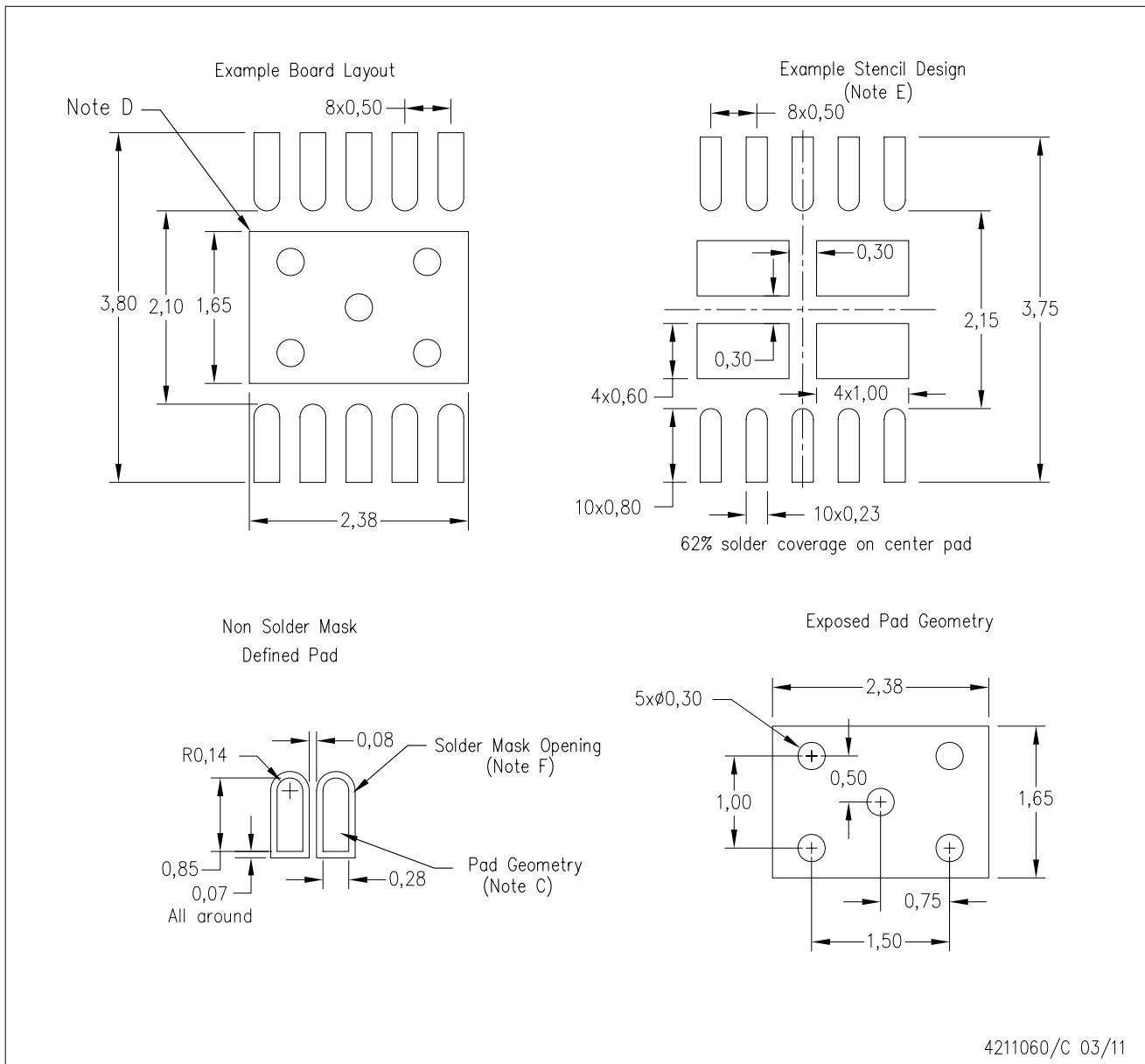

- NOTES:
- All linear dimensions are in millimeters.
 - This drawing is subject to change without notice.
 - Publication IPC-7351 is recommended for alternate designs.
 - This package is designed to be soldered to a thermal pad on the board. Refer to Application Note, Quad Flat-Pack Packages, Texas Instruments Literature No. SLUA271, and also the Product Data Sheets for specific thermal information, via requirements, and recommended board layout. These documents are available at www.ti.com <<http://www.ti.com>>.
 - Laser cutting apertures with trapezoidal walls and also rounding corners will offer better paste release. Customers should contact their board assembly site for stencil design recommendations. Refer to IPC 7525 for stencil design considerations.
 - Customers should contact their board fabrication site for minimum solder mask web tolerances between signal pads.

IMPORTANT NOTICE

Texas Instruments Incorporated (TI) reserves the right to make corrections, enhancements, improvements and other changes to its semiconductor products and services per JESD46, latest issue, and to discontinue any product or service per JESD48, latest issue. Buyers should obtain the latest relevant information before placing orders and should verify that such information is current and complete.

TI's published terms of sale for semiconductor products (<http://www.ti.com/sc/docs/stdterms.htm>) apply to the sale of packaged integrated circuit products that TI has qualified and released to market. Additional terms may apply to the use or sale of other types of TI products and services.

Reproduction of significant portions of TI information in TI data sheets is permissible only if reproduction is without alteration and is accompanied by all associated warranties, conditions, limitations, and notices. TI is not responsible or liable for such reproduced documentation. Information of third parties may be subject to additional restrictions. Resale of TI products or services with statements different from or beyond the parameters stated by TI for that product or service voids all express and any implied warranties for the associated TI product or service and is an unfair and deceptive business practice. TI is not responsible or liable for any such statements.

Buyers and others who are developing systems that incorporate TI products (collectively, "Designers") understand and agree that Designers remain responsible for using their independent analysis, evaluation and judgment in designing their applications and that Designers have full and exclusive responsibility to assure the safety of Designers' applications and compliance of their applications (and of all TI products used in or for Designers' applications) with all applicable regulations, laws and other applicable requirements. Designer represents that, with respect to their applications, Designer has all the necessary expertise to create and implement safeguards that (1) anticipate dangerous consequences of failures, (2) monitor failures and their consequences, and (3) lessen the likelihood of failures that might cause harm and take appropriate actions. Designer agrees that prior to using or distributing any applications that include TI products, Designer will thoroughly test such applications and the functionality of such TI products as used in such applications.

TI's provision of technical, application or other design advice, quality characterization, reliability data or other services or information, including, but not limited to, reference designs and materials relating to evaluation modules, (collectively, "TI Resources") are intended to assist designers who are developing applications that incorporate TI products; by downloading, accessing or using TI Resources in any way, Designer (individually or, if Designer is acting on behalf of a company, Designer's company) agrees to use any particular TI Resource solely for this purpose and subject to the terms of this Notice.

TI's provision of TI Resources does not expand or otherwise alter TI's applicable published warranties or warranty disclaimers for TI products, and no additional obligations or liabilities arise from TI providing such TI Resources. TI reserves the right to make corrections, enhancements, improvements and other changes to its TI Resources. TI has not conducted any testing other than that specifically described in the published documentation for a particular TI Resource.

Designer is authorized to use, copy and modify any individual TI Resource only in connection with the development of applications that include the TI product(s) identified in such TI Resource. NO OTHER LICENSE, EXPRESS OR IMPLIED, BY ESTOPPEL OR OTHERWISE TO ANY OTHER TI INTELLECTUAL PROPERTY RIGHT, AND NO LICENSE TO ANY TECHNOLOGY OR INTELLECTUAL PROPERTY RIGHT OF TI OR ANY THIRD PARTY IS GRANTED HEREIN, including but not limited to any patent right, copyright, mask work right, or other intellectual property right relating to any combination, machine, or process in which TI products or services are used. Information regarding or referencing third-party products or services does not constitute a license to use such products or services, or a warranty or endorsement thereof. Use of TI Resources may require a license from a third party under the patents or other intellectual property of the third party, or a license from TI under the patents or other intellectual property of TI.

TI RESOURCES ARE PROVIDED "AS IS" AND WITH ALL FAULTS. TI DISCLAIMS ALL OTHER WARRANTIES OR REPRESENTATIONS, EXPRESS OR IMPLIED, REGARDING RESOURCES OR USE THEREOF, INCLUDING BUT NOT LIMITED TO ACCURACY OR COMPLETENESS, TITLE, ANY EPIDEMIC FAILURE WARRANTY AND ANY IMPLIED WARRANTIES OF MERCHANTABILITY, FITNESS FOR A PARTICULAR PURPOSE, AND NON-INFRINGEMENT OF ANY THIRD PARTY INTELLECTUAL PROPERTY RIGHTS. TI SHALL NOT BE LIABLE FOR AND SHALL NOT DEFEND OR INDEMNIFY DESIGNER AGAINST ANY CLAIM, INCLUDING BUT NOT LIMITED TO ANY INFRINGEMENT CLAIM THAT RELATES TO OR IS BASED ON ANY COMBINATION OF PRODUCTS EVEN IF DESCRIBED IN TI RESOURCES OR OTHERWISE. IN NO EVENT SHALL TI BE LIABLE FOR ANY ACTUAL, DIRECT, SPECIAL, COLLATERAL, INDIRECT, PUNITIVE, INCIDENTAL, CONSEQUENTIAL OR EXEMPLARY DAMAGES IN CONNECTION WITH OR ARISING OUT OF TI RESOURCES OR USE THEREOF, AND REGARDLESS OF WHETHER TI HAS BEEN ADVISED OF THE POSSIBILITY OF SUCH DAMAGES.

Unless TI has explicitly designated an individual product as meeting the requirements of a particular industry standard (e.g., ISO/TS 16949 and ISO 26262), TI is not responsible for any failure to meet such industry standard requirements.

Where TI specifically promotes products as facilitating functional safety or as compliant with industry functional safety standards, such products are intended to help enable customers to design and create their own applications that meet applicable functional safety standards and requirements. Using products in an application does not by itself establish any safety features in the application. Designers must ensure compliance with safety-related requirements and standards applicable to their applications. Designer may not use any TI products in life-critical medical equipment unless authorized officers of the parties have executed a special contract specifically governing such use. Life-critical medical equipment is medical equipment where failure of such equipment would cause serious bodily injury or death (e.g., life support, pacemakers, defibrillators, heart pumps, neurostimulators, and implantables). Such equipment includes, without limitation, all medical devices identified by the U.S. Food and Drug Administration as Class III devices and equivalent classifications outside the U.S.

TI may expressly designate certain products as completing a particular qualification (e.g., Q100, Military Grade, or Enhanced Product). Designers agree that it has the necessary expertise to select the product with the appropriate qualification designation for their applications and that proper product selection is at Designers' own risk. Designers are solely responsible for compliance with all legal and regulatory requirements in connection with such selection.

Designer will fully indemnify TI and its representatives against any damages, costs, losses, and/or liabilities arising out of Designer's non-compliance with the terms and provisions of this Notice.

Looking for pricing, stock, or lifecycle information?

Click below to explore more details on WIN SOURCE:

 [View DRV10963JADSNT on WIN SOURCE](#)

 [Texas Instruments](#) Information

Optimize Your Supply Chain with WIN SOURCE Solutions

-  Global Sourcing Solution
-  Obsolete Management
-  Cost Control Management
-  Shortage Management
-  Alternative Solution
-  Excess Inventory Management