



**THE DATASHEET OF
BGF120AE6327XTSA1**



TVS Diodes

Transient Voltage Suppressor Diodes

BGF120A

Dual Channel Ultra-Low Capacitance ESD Diode

Datasheet

Rev. 1.4, 2012-09-17
Final

Edition 2012-09-17

**Published by
Infineon Technologies AG
81726 Munich, Germany**

**© 2012 Infineon Technologies AG
All Rights Reserved.**

Legal Disclaimer

The information given in this document shall in no event be regarded as a guarantee of conditions or characteristics. With respect to any examples or hints given herein, any typical values stated herein and/or any information regarding the application of the device, Infineon Technologies hereby disclaims any and all warranties and liabilities of any kind, including without limitation, warranties of non-infringement of intellectual property rights of any third party.

Information

For further information on technology, delivery terms and conditions and prices, please contact the nearest Infineon Technologies Office (www.infineon.com).

Warnings

Due to technical requirements, components may contain dangerous substances. For information on the types in question, please contact the nearest Infineon Technologies Office.

Infineon Technologies components may be used in life-support devices or systems only with the express written approval of Infineon Technologies, if a failure of such components can reasonably be expected to cause the failure of that life-support device or system or to affect the safety or effectiveness of that device or system. Life support devices or systems are intended to be implanted in the human body or to support and/or maintain and sustain and/or protect human life. If they fail, it is reasonable to assume that the health of the user or other persons may be endangered.

Revision History Rev.1.3, 2012-08-01

Page or Item	Subjects (major changes since previous revision)
--------------	--

Rev. 1.4, 2012-09-17

12	Package outline updated

Trademarks of Infineon Technologies AG

AURIX™, C166™, CanPAK™, CIPOS™, CIPURSE™, EconoPACK™, CoolMOS™, CoolSET™, CORECONTROL™, CROSSAVE™, DAVE™, DI-POL™, EasyPIM™, EconoBRIDGE™, EconoDUAL™, EconoPIM™, EconoPACK™, EiceDRIVER™, eupec™, FCOS™, HITFET™, HybridPACK™, I²RF™, ISOFACE™, IsoPACK™, MIPAQ™, ModSTACK™, my-d™, NovalithIC™, OptiMOS™, ORIGA™, POWERCODE™; PRIMARION™, PrimePACK™, PrimeSTACK™, PRO-SIL™, PROFET™, RASIC™, ReverSave™, SatRIC™, SIEGET™, SINDRION™, SIPMOS™, SmartLEWIS™, SOLID FLASH™, TEMPFET™, thinQ!™, TRENCHSTOP™, TriCore™.

Other Trademarks

Advance Design System™ (ADS) of Agilent Technologies, AMBA™, ARM™, MULTI-ICE™, KEIL™, PRIMECELL™, REALVIEW™, THUMB™, µVision™ of ARM Limited, UK. AUTOSAR™ is licensed by AUTOSAR development partnership. Bluetooth™ of Bluetooth SIG Inc. CAT-iq™ of DECT Forum. COLOSSUS™, FirstGPS™ of Trimble Navigation Ltd. EMV™ of EMVCo, LLC (Visa Holdings Inc.). EPCOS™ of Epcos AG. FLEXGO™ of Microsoft Corporation. FlexRay™ is licensed by FlexRay Consortium. HYPERTERMINAL™ of Hilgraeve Incorporated. IEC™ of Commission Electrotechnique Internationale. IrDA™ of Infrared Data Association Corporation. ISO™ of INTERNATIONAL ORGANIZATION FOR STANDARDIZATION. MATLAB™ of MathWorks, Inc. MAXIM™ of Maxim Integrated Products, Inc. MICROTEC™, NUCLEUS™ of Mentor Graphics Corporation. MIPI™ of MIPI Alliance, Inc. MIPS™ of MIPS Technologies, Inc., USA. muRata™ of MURATA MANUFACTURING CO., MICROWAVE OFFICE™ (MWO) of Applied Wave Research Inc., OmniVision™ of OmniVision Technologies, Inc. Openwave™ Openwave Systems Inc. RED HAT™ Red Hat, Inc. RFMD™ RF Micro Devices, Inc. SIRIUS™ of Sirius Satellite Radio Inc. SOLARIS™ of Sun Microsystems, Inc. SPANSION™ of Spansion LLC Ltd. Symbian™ of Symbian Software Limited. TAIYO YUDEN™ of Taiyo Yuden Co. TEAKLITE™ of CEVA, Inc. TEKTRONIX™ of Tektronix Inc. TOKO™ of TOKO KABUSHIKI KAISHA TA. UNIX™ of X/Open Company Limited. VERILOG™, PALLADIUM™ of Cadence Design Systems, Inc. VLYNQ™ of Texas Instruments Incorporated. VXWORKS™, WIND RIVER™ of WIND RIVER SYSTEMS, INC. ZETEX™ of Diodes Zetex Limited.

Last Trademarks Update 2011-11-11

1 BGF120A Dual Channel Ultra-Low Capacitance ESD Diode

1.1 Features

- ESD /transient protection of high-speed data and RF antenna lines exceeding:
 - IEC61000-4-2 (ESD): 18 kV (contact)
- Max. reverse working voltage: 5.3 V
- Ultra-low capacitance:
 - < 0.75 pF (max.) in bi-directional configuration
 - < 1.5 pF (max.) in uni-directional configuration
- Very low reverse current: < 1 nA (typ.)
- Small leadless plastic package with 0.75 mm x 0.75 mm size (typ.) and 0.66 mm height (max.)
- 400 μm pad pitch and 40 μm Sn solder depot on pads
- RoHS and WEEE compliant package



1.2 Application

- USB 2.0, 10/100/1000 Ethernet, Firewire, DVI, HDMI, S-ATA
- RF antenna protection e.g. GPS, FM radio, mobile TV

1.3 Description

The BGF120A can be used for 2 lines uni-directional or 1 line bi-directional ESD and surge protection up to 20 kV contact discharge according to IEC61000-4-2. The capacitance of the device is less than 0.75 pF (max.) in bi-directional configuration and less than 1.5 pF (max.) in uni-directional configuration. Maximum reverse working voltage is 5.3 V (uni-directional) or ±5.3 V (bi-directional). The reverse leakage current is less than 1 nA (typ.). The leadless plastic package has 0.75 mm x 0.75 mm typical size and maximum height of 0.66 mm. The pads have 400 μm pitch and offer 40 μm Sn for high reliability soldering

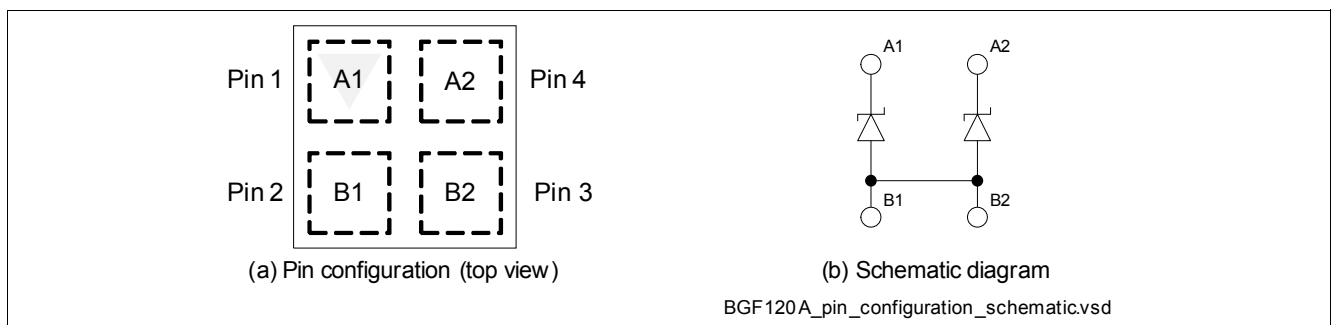

Figure 1-1 Pin Configuration and Schematic Diagram

Type	Package	Configuration	Marking code
BGF120A	TSLP-4-8	2 lines, uni-directional ¹⁾	A

1) Or 1 line, bi-directional between A1 and A2, if B1, B2 are not connected

2 Electrical Characteristics

Table 2-1 Maximum Ratings $T_A = 25\text{ }^\circ\text{C}$, unless otherwise specified

Parameter	Symbol	Values			Unit	Note / Test Condition
		Min.	Typ.	Max.		
Operating temperature range	T_{OP}	-40	-	+125	$^\circ\text{C}$	
Storage temperature range	T_{STG}	-65	-	+150	$^\circ\text{C}$	
Contact discharge ¹⁾	V_{ESD}	-	-	18	kV	

 1) V_{ESD} according to IEC61000-4-2

Attention: Stresses above the max. values listed here may cause permanent damage to the device. Exposure to absolute maximum rating conditions for extended periods may affect device reliability. Maximum ratings are absolute ratings; exceeding only one of these values may cause irreversible damage to the integrated circuit.

Table 2-2 DC Electrical Characteristics $T_A = 25\text{ }^\circ\text{C}$, unless otherwise specified

Parameter	Symbol	Values			Unit	Note / Test Condition
		Min.	Typ.	Max.		
Reverse working voltage	V_{RWM}	-	-	5.3	V	
Breakdown voltage	V_{BR}	6	-	-	V	$I_{BR} = 1\text{ mA}$
Reverse current	I_R	-	<1	50	nA	$V_R = 5.3\text{V}$

Table 2-3 DC Electrical Characteristics $T_A = 25\text{ }^\circ\text{C}$, unless otherwise specified

Parameter	Symbol	Values			Unit	Note / Test Condition
		Min.	Typ.	Max.		
Line capacitance ¹⁾ A1 or A2 to B1/B2	C_L	-	-	1.5	pF	$V_R = 0\text{ V}, f = 1\text{ MHz}$
A1 to A2, B1/B2 n.c.		-	-	0.75		
Series inductance per diode	L_S	-	0.25	-	nH	

1) Total capacitance line to ground

Table 2-4 ESD Characteristics at $T_A = 25\text{ °C}$, unless otherwise specified

Parameter	Symbol	Values			Unit	Note / Test Condition
		Min.	Typ.	Max.		
Reverse clamping voltage ¹⁾ A1 or A2 vs B1, B2 A1 or A2 vs B1, B2	V_{CL}	-	22	-	V	$I_{TLP} = 16\text{ A}$,
		-	31	-		$I_{TLP} = 30\text{ A}$,
Forward clamping voltage ¹⁾ A1 or A2 vs B1, B2 A1 or A2 vs B1, B2	V_{FC}	-	-14	-	V	$I_{TLP} = -16\text{ A}$,
		-	-20	-		$I_{TLP} = -30\text{ A}$,
Dynamic resistance ¹⁾ positive pulse A1 or A2 vs. B1, B2 negative pulse A1 or A2 vs B1, B2	R_{DYN}	-	0.7	-	Ω	
		-	0.5	-		

1) ANSI/ESD STM5.5.1 - Electrostatic Discharge Sensitive Testing using Transmission Line Pulse (TLP) Model. TLP conditions: $Z_0 = 50\ \Omega$, $t_p = 100\text{ ns}$, $t_r = 0.6\text{ ns}$, I_{TLP} and V_{TLP} averaging window: $t_1 = 30\text{ ns}$ to $t_2 = 60\text{ ns}$, extraction of dynamic resistance using least squares fit of TLP characteristic between $I_{PP1} = 10\text{ A}$ and $I_{PP2} = 30\text{ A}$. Please refer to Application Note AN210[1].

3 Typical Characteristics

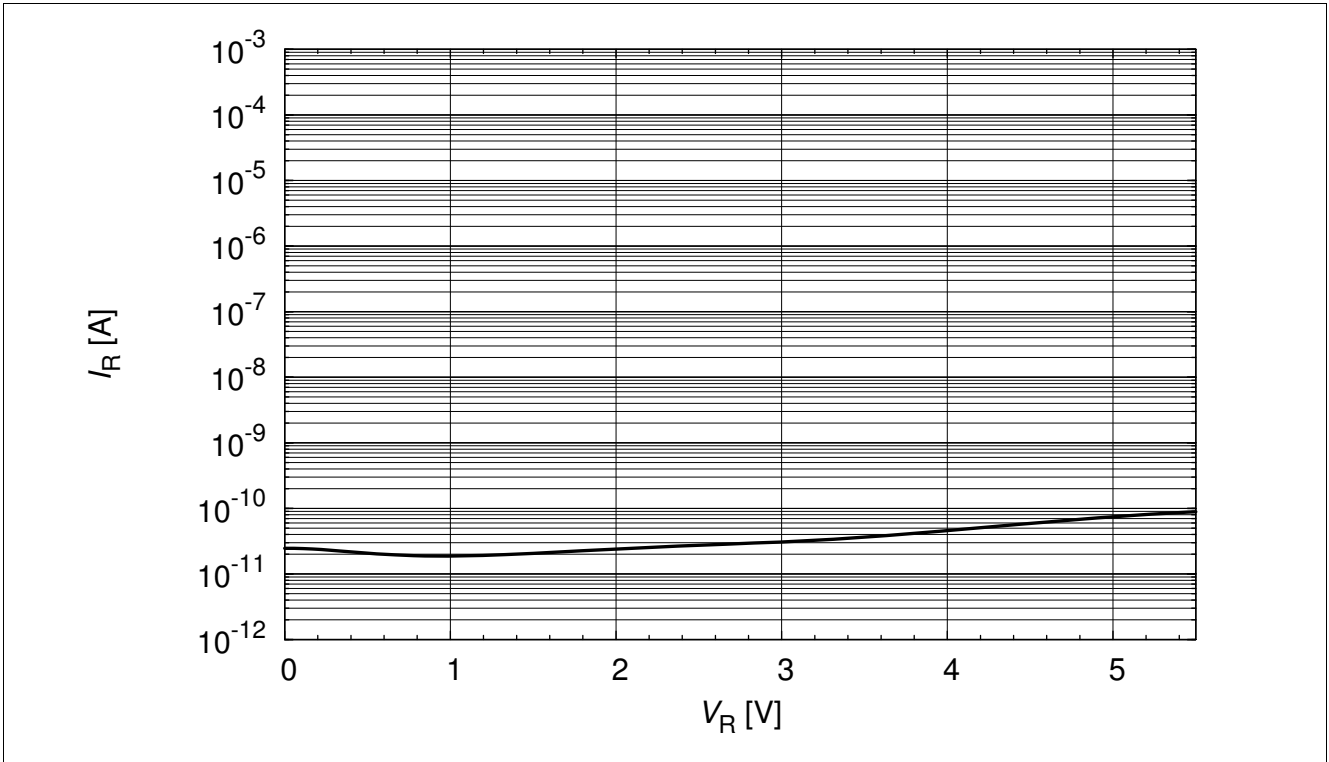

Figure 3-1 Reverse current $I_R = f(V_R)$

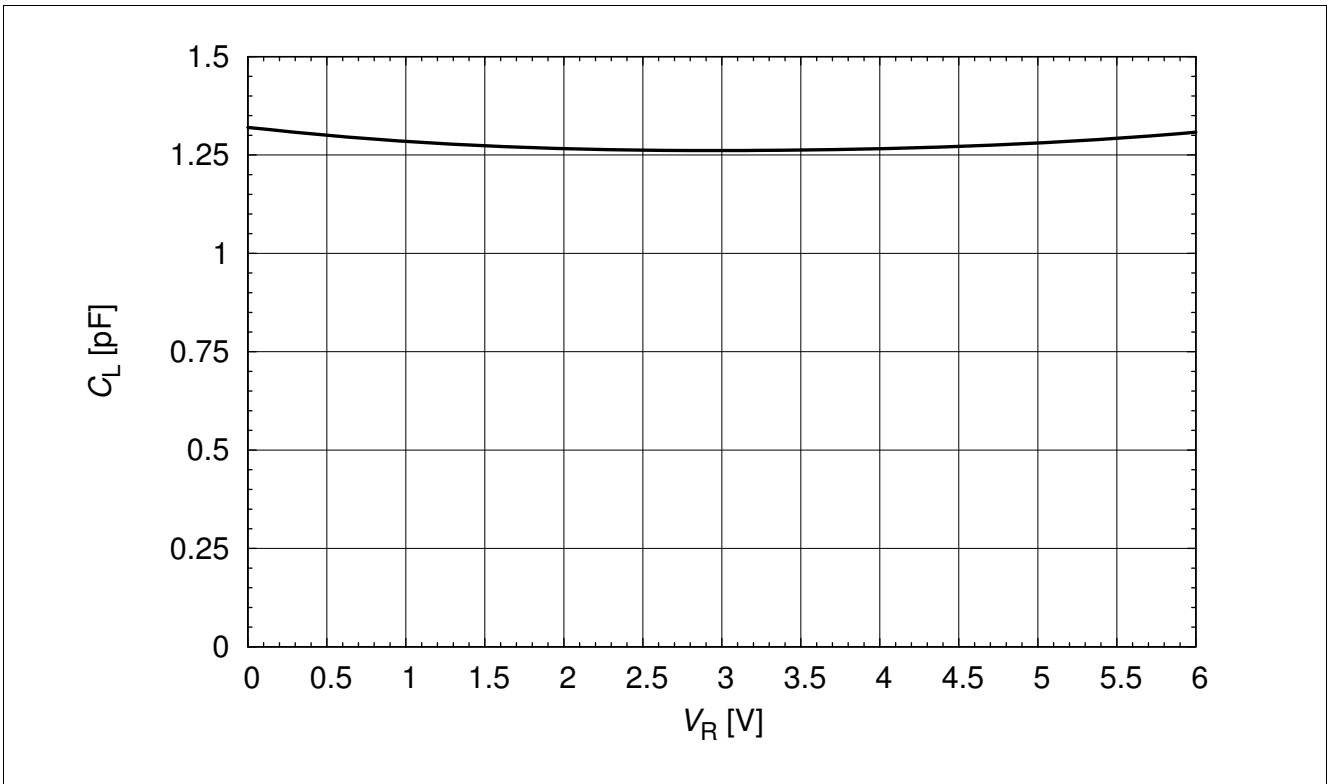

Figure 3-2 Capacitance A1 vs. B1, A2 vs. B2, $C_{L(A1,B1)} = C_{L(A2,B2)} = f(V_R)$

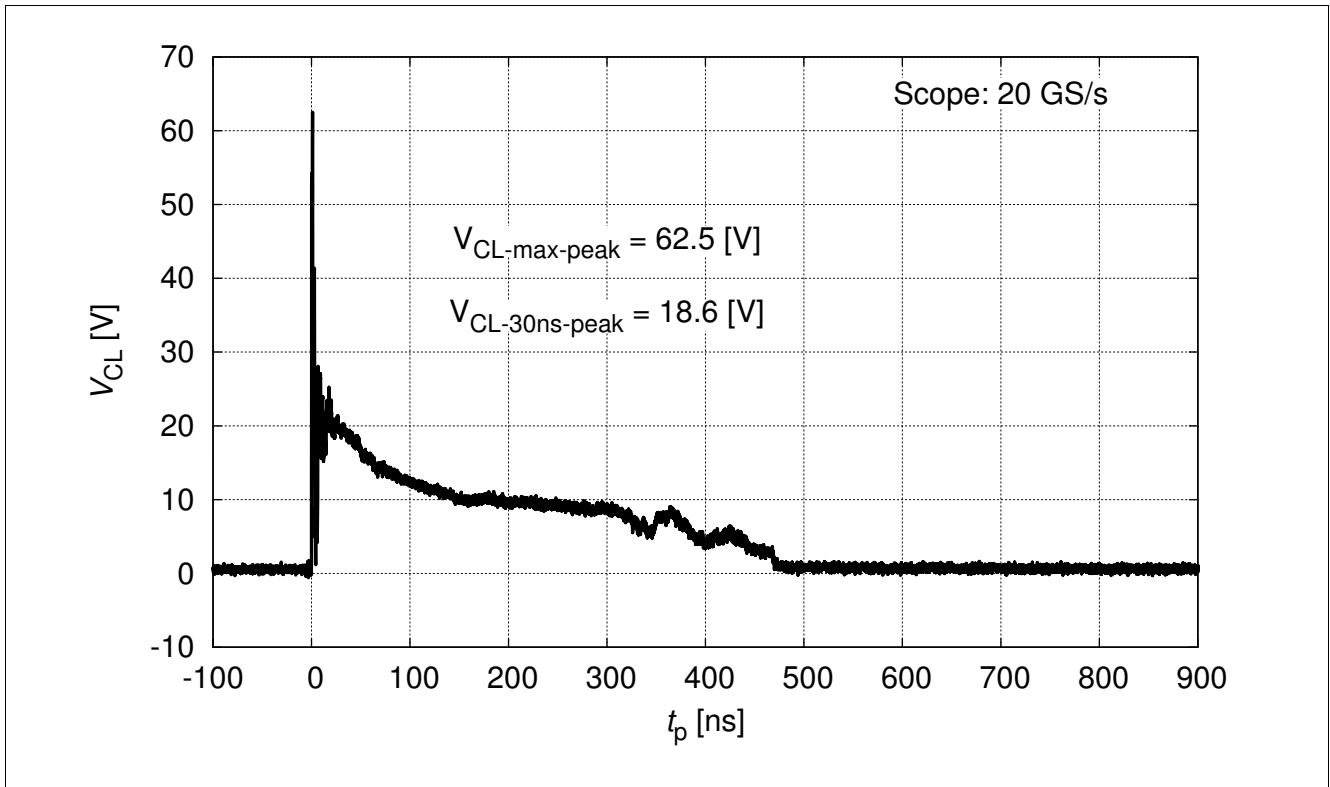

Figure 3-3 Clamping voltage at +8 kV discharge according IEC61000-4-2 ($R = 330 \Omega$, $C = 150 \text{ pF}$)

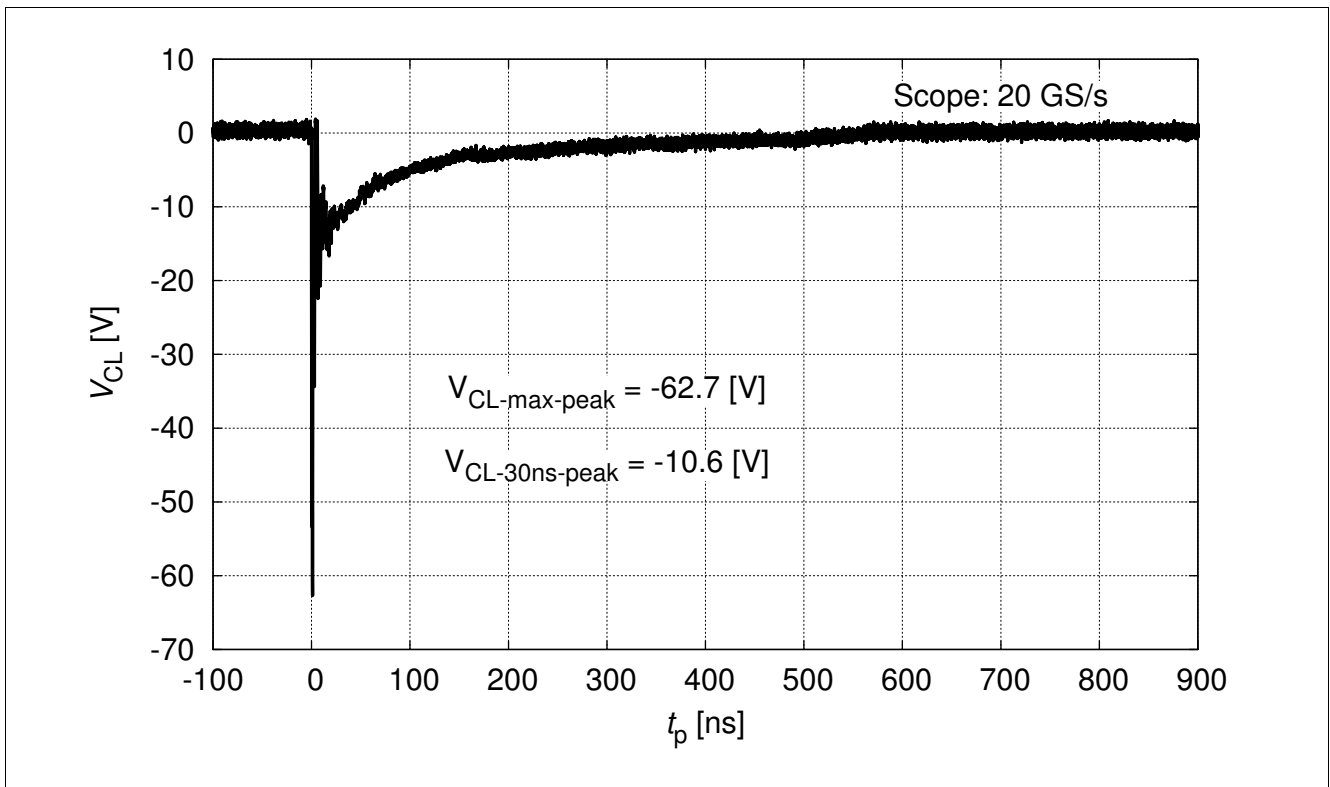

Figure 3-4 Clamping voltage at -8 kV discharge according IEC61000-4-2 ($R = 330 \Omega$, $C = 150 \text{ pF}$)

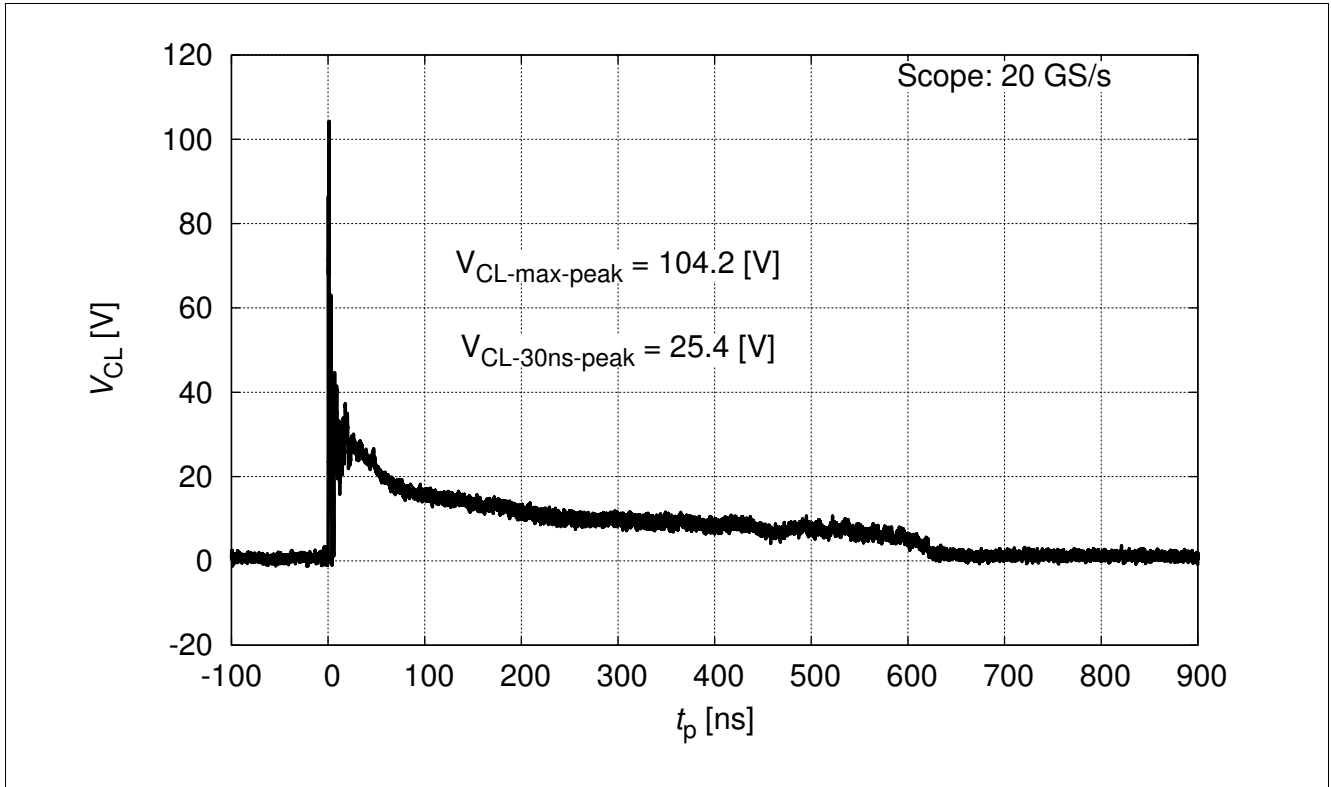

Figure 3-5 Clamping voltage at +15 kV discharge according IEC61000-4-2 ($R = 330 \text{ Ohm}$, $C = 150 \text{ pF}$)

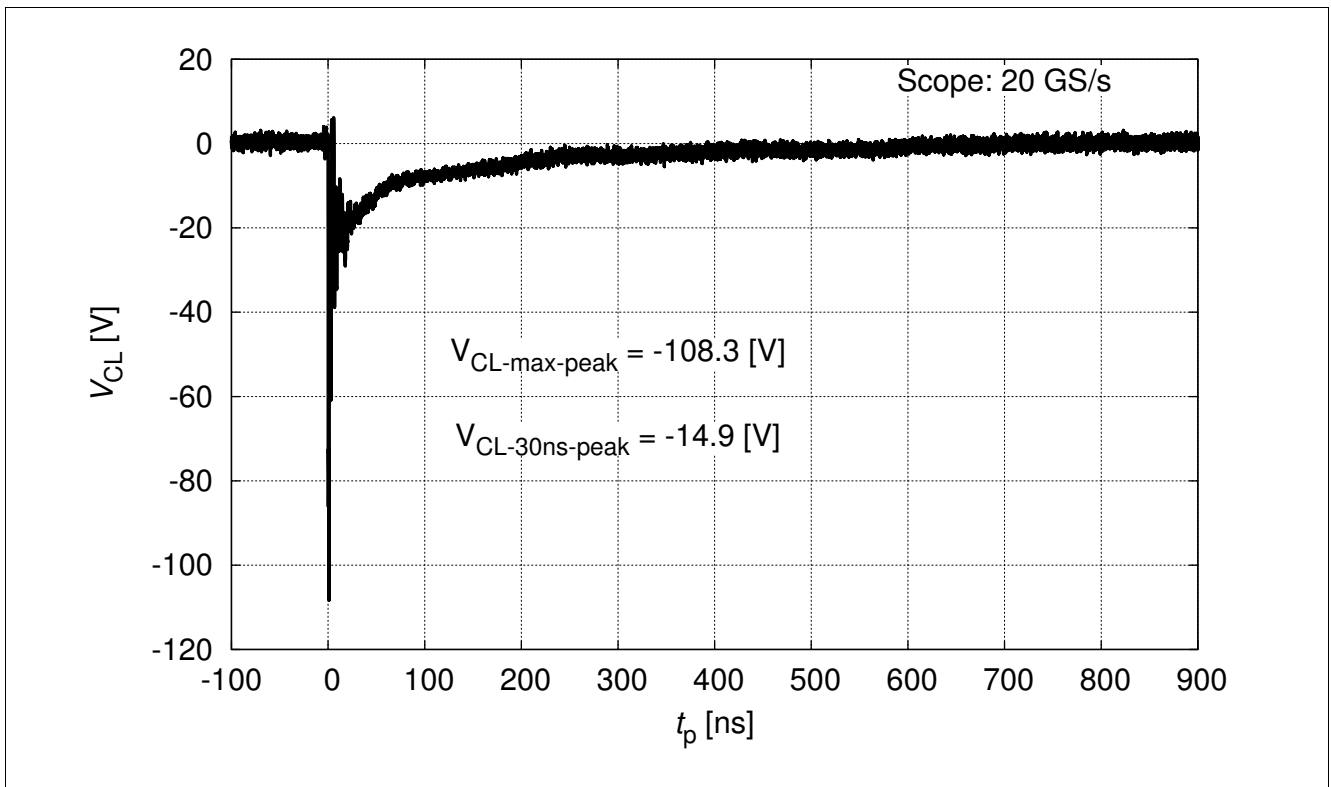

Figure 3-6 Clamping voltage at -15 kV discharge according IEC61000-4-2 ($R = 330 \text{ } \Omega$, $C = 150 \text{ pF}$)

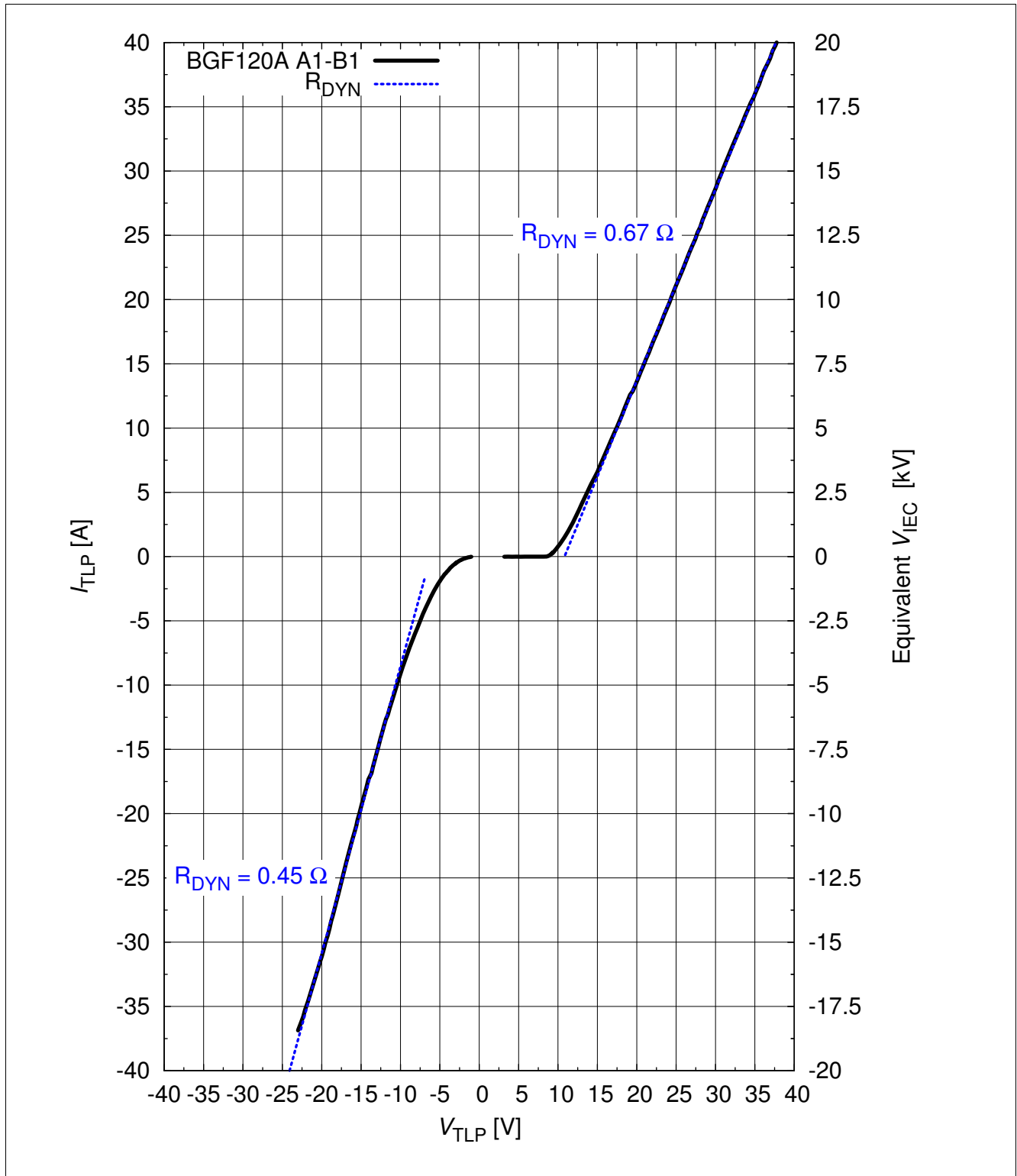

Figure 3-7 Clamping voltage (TLP): $I_{TLP} = f(V_{TLP})$ according ANSI/ESD STM5.5.1- Electrostatic Discharge Sensitivity Testing using Transmission Line Pulse (TLP) Model. TLP conditions: $Z_0 = 50 \Omega$, $t_p = 100 \text{ ns}$, $t_r = 0.6 \text{ ns}$, I_{TLP} and V_{TLP} averaging window: $t_1 = 30 \text{ ns}$ to $t_2 = 60 \text{ ns}$, extraction of dynamic resistance using squares fit to ELP characteristic between $I_{TLP1} = 10 \text{ A}$ and $I_{TLP2} = 30 \text{ A}$. Please refer to Application Note AN210 [1]

4 Application and Signal Routing

Application example for high-speed data line protection (uni-directional)

This low parasitic capacitance dual channel TVS diode array can be used either in a 2 channel uni-directional configuration or in a single channel bi-directional configuration. Due to the low capacitance and low inductance the configurations are perfect fit for ultra high-speed interfaces, such as USB2.0/3.0, S-ATA, DVI or HDMI ports.

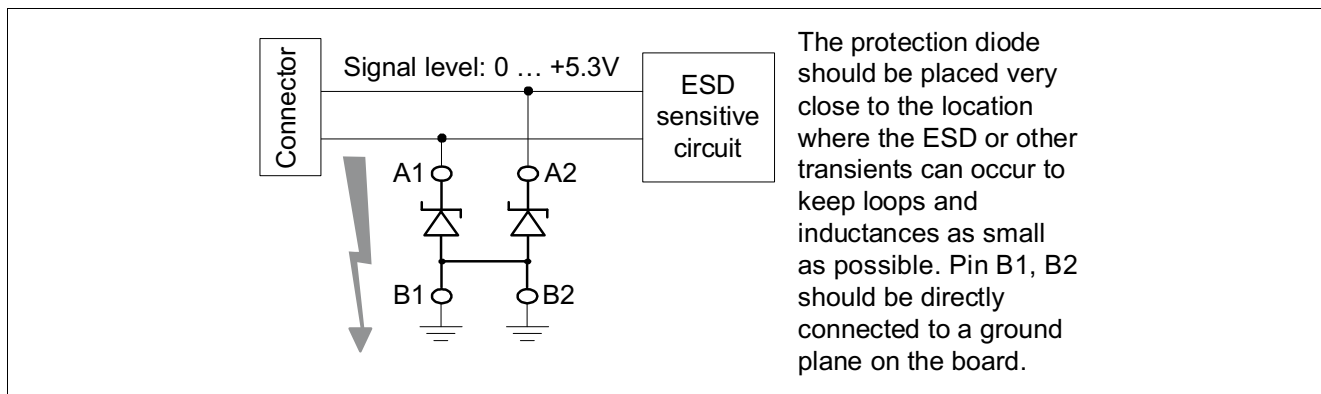

Figure 4-1 Application example for high-speed data line protection (uni-directional)

Application example for RF antenna line (bi-directional)

Connecting pin A1(A2) to the signal line and A2(A1) to GND and leaving pin B1/B2 floating even further reduces the parasitics to 0.75 pF only and correspondingly enable the user to add reliable ESD protection to RF antennas in e.g. GPS, FM radio or mobile TV applications without influence of the RF circuitry.

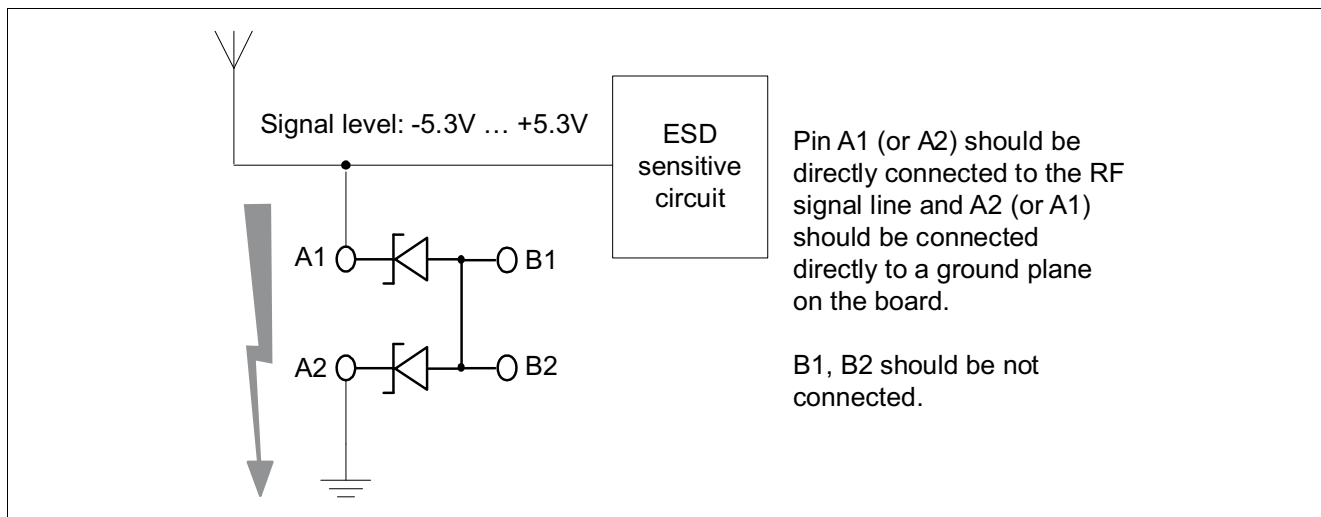

Figure 4-2 Application example for RF antenna line (bi-directional)

5 Package

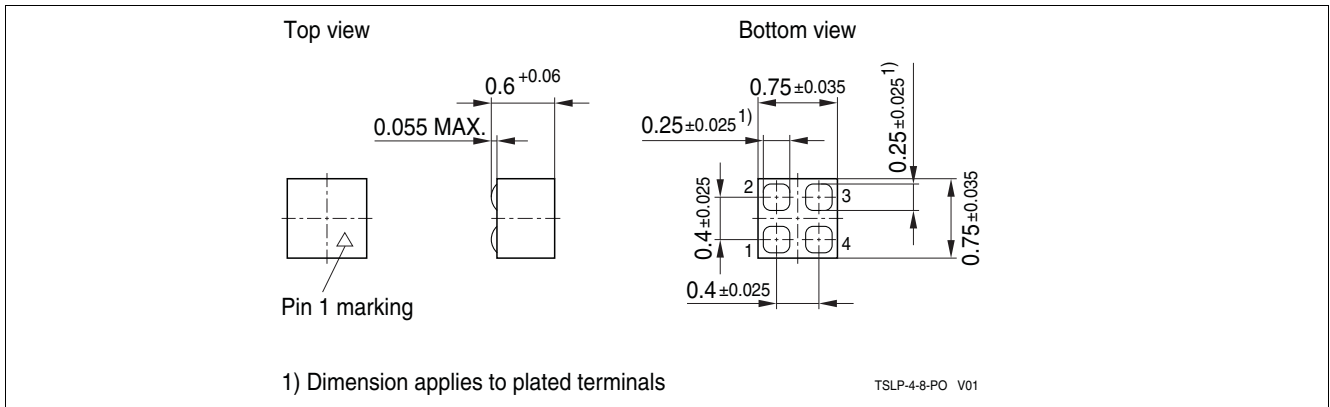

Figure 5-1 Package outline for TSLP-4-8 (dimension in mm)

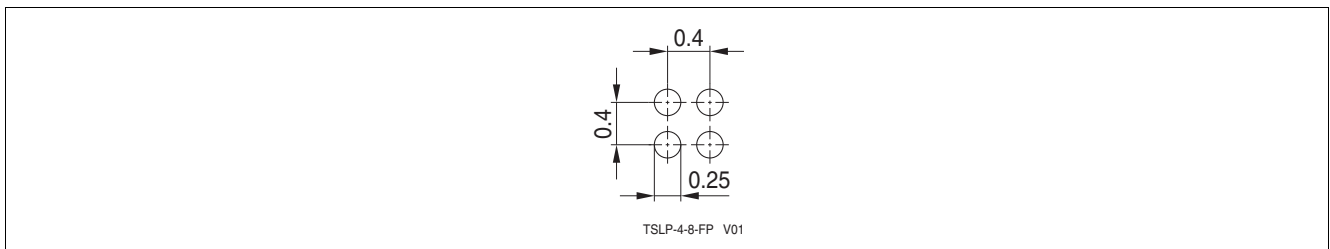

Figure 5-2 Package footprint for TSLP-4-8 (dimension in mm)

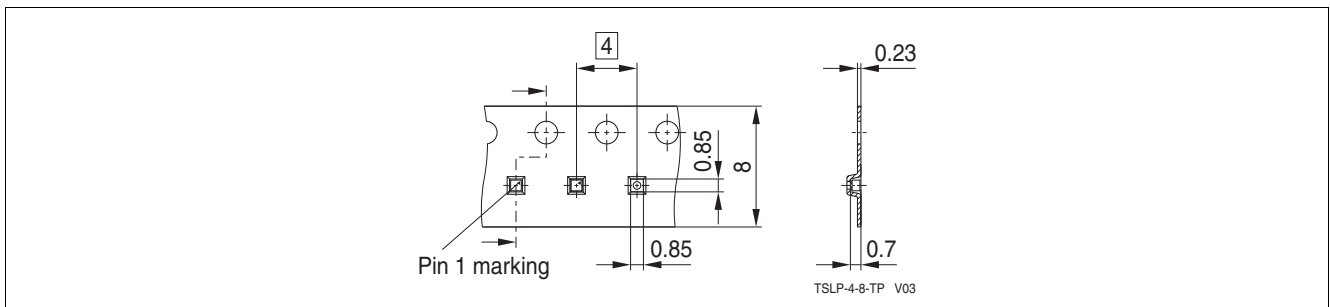

Figure 5-3 Tape and Reel Information for TSLP-4-8 (dimension in mm)

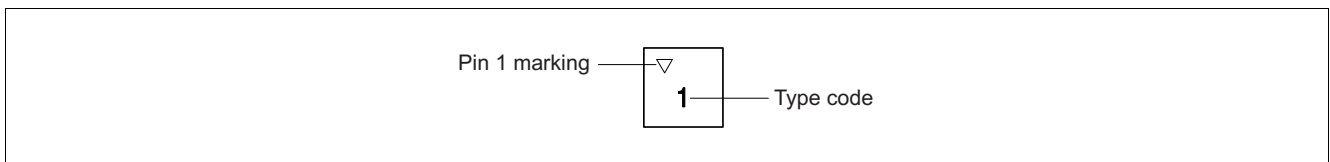

Figure 5-4 Marking (example) for TSLP-4-8

References



- [1] Infineon Technologies AG, "Effective ESD Protection Design at System Level Using VF-TLP Characterization Methodology", Application Note 210, RF and Protection Devices, April 22, 2010, Rev.1.0
- [2] Infineon Technologies AG, "Recommendation for PCB Assembly of Infineon TSLP and TSSLP Packages".

www.infineon.com

Published by Infineon Technologies AG

Looking for pricing, stock, or lifecycle information?

Click below to explore more details on WIN SOURCE:

-  [View BGF120AE6327XTSA1 on WIN SOURCE](#)
-  [Infineon Technologies Information](#)

Optimize Your Supply Chain with WIN SOURCE Solutions

-  Global Sourcing Solution
-  Obsolete Management
-  Cost Control Management
-  Shortage Management
-  Alternative Solution
-  Excess Inventory Management