



**THE DATASHEET OF
LP3943ISQX/NOPB**



LP3943 16-Channel RGB, White-LED Driver With Independent SMBUS/I²C String Control

1 Features

- Internal Power-On Reset
- Active Low Reset
- Internal Precision Oscillator
- Variable Dim Rates
(From 6.25 ms to 1.6 s; 160 Hz to 0.625 Hz)
- 16 LED Drivers (Multiple Programmable States: ON, OFF, Input, and Dimming at a Specified Rate)
- 16 Open-Drain Outputs Capable of Driving up to 25 mA per LED

2 Applications

- Customized Flashing LED Lights for Cellular Phones
- Portable Applications
- Digital Cameras
- Indicator Lamps
- General Purpose I/O Expander
- Toys

3 Description

The LP3943 is an integrated device capable of independently driving 16 LEDs. This device also contains an internal precision oscillator that provides all the necessary timing required for driving each LED. Two prescaler registers, along with two PWM registers, provide a versatile duty-cycle control. The LP3943 contains the ability to dim LEDs in SMBUS/I²C applications where it is required, to cut down on bus traffic.

Traditionally, dimming LEDs using a serial shift register such as 74LS594/5 requires a large amount of traffic on the serial bus. The LP3943 instead requires only the setup of the frequency and duty cycle for each output pin; from then on, only a single command from the host is required to turn each individual open drain output to an ON or OFF state, or to cycle a programmed frequency and duty cycle. Maximum output sink current is 25 mA per pin and 200 mA per package. Any ports not used for controlling the LEDs can be used for general purpose input/output expansion.

Device Information⁽¹⁾

PART NUMBER	PACKAGE	BODY SIZE (NOM)
LP3943	WQFN (24)	4.00 mm x 4.00 mm

(1) For all available packages, see the orderable addendum at the end of the data sheet.

Typical Application Circuit

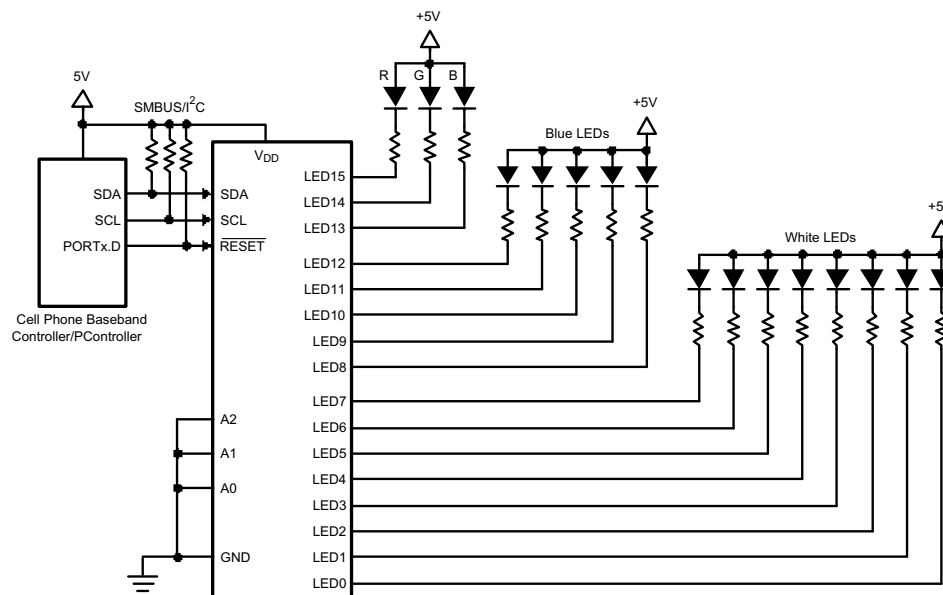

Table of Contents

1 Features	1	7.5 Programming.....	9
2 Applications	1	7.6 Register Maps.....	12
3 Description	1	8 Application and Implementation	15
4 Revision History	2	8.1 Application Information.....	15
5 Pin Configuration and Functions	3	8.2 Typical Application	15
6 Specifications	4	8.3 System Examples	17
6.1 Absolute Maximum Ratings	4	9 Power Supply Recommendations	17
6.2 ESD Ratings.....	4	10 Layout	18
6.3 Recommended Operating Conditions.....	4	10.1 Layout Guidelines	18
6.4 Thermal Information	4	10.2 Layout Example	18
6.5 Electrical Characteristics.....	5	11 Device and Documentation Support	19
6.6 I ² C Interface (SCL and SDA Pins) Timing Requirements.....	6	11.1 Receiving Notification of Documentation Updates	19
6.7 Typical Characteristic	6	11.2 Community Resources.....	19
7 Detailed Description	7	11.3 Trademarks	19
7.1 Overview	7	11.4 Electrostatic Discharge Caution.....	19
7.2 Functional Block Diagram	7	11.5 Glossary	19
7.3 Feature Description.....	8	12 Mechanical, Packaging, and Orderable Information	19
7.4 Device Functional Modes.....	8		

4 Revision History

NOTE: Page numbers for previous revisions may differ from page numbers in the current version.

Changes from Revision C (October 2015) to Revision D	Page
• Changed change wording of title to add SEO keywords	1
• Changed R _{θJA} value from "37°C/W" to "45.0°C/W"; add additional thermal values	4

Changes from Revision B (September 2013) to Revision C	Page
• Added <i>Device Information</i> and <i>Pin Configuration and Functions</i> sections, <i>ESD Ratings</i> table, <i>Feature Description</i> , <i>Device Functional Modes</i> , <i>Application and Implementation</i> , <i>Power Supply Recommendations</i> , <i>Layout</i> , <i>Device and Documentation Support</i> , and <i>Mechanical, Packaging, and Orderable Information</i> sections.	1

Changes from Revision A (April 2013) to Revision B	Page
• Changed layout of National Data Sheet to TI format; fixed format of Block Diagram.....	7

5 Pin Configuration and Functions

**RTW Package
24-Pin WQFN With Exposed Pad
Top View**

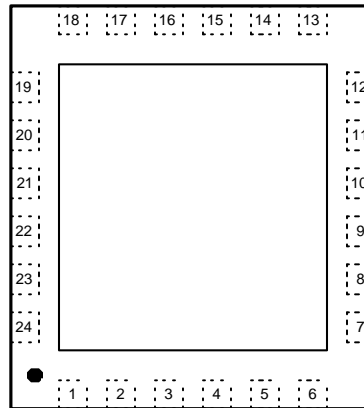

Pin Functions

PIN		I/O	DESCRIPTION
NUMBER	NAME		
1	LED0	Output	Output of LED0 Driver
2	LED1	Output	Output of LED1 Driver
3	LED2	Output	Output of LED2 Driver
4	LED3	Output	Output of LED3 Driver
5	LED4	Output	Output of LED4 Driver
6	LED5	Output	Output of LED5 Driver
7	LED6	Output	Output of LED6 Driver
8	LED7	Output	Output of LED7 Driver
9	GND	Ground	Ground
10	LED8	Output	Output of LED8 Driver
11	LED9	Output	Output of LED9 Driver
12	LED10	Output	Output of LED10 Driver
13	LED11	Output	Output of LED11 Driver
14	LED12	Output	Output of LED12 Driver
15	LED13	Output	Output of LED13 Driver
16	LED14	Output	Output of LED14 Driver
17	LED15	Output	Output of LED15 Driver
18	$\overline{\text{RST}}$	Input	Active Low Reset Input
19	SCL	Input	Clock Line for I ² C Interface
20	SDA	Input/Output	Serial Data Line for I ² C Interface
21	VDD	Power	Power Supply
22	A0	Input	Address Input 0
23	A1	Input	Address Input 1
24	A2	Input	Address Input 2
—	Exposed Pad	—	Tie internally to GND pin.

6 Specifications

6.1 Absolute Maximum Ratings

over operating free-air temperature range (unless otherwise noted)⁽¹⁾⁽²⁾⁽³⁾

	MIN	MAX	UNIT
V _{DD}	-0.5	6	V
A0, A1, A2, SCL, SDA, $\overline{\text{RST}}$ (Collectively called digital pins)		6	V
Voltage on LED pins	V _{SS} - 0.5	6	V
Junction temperature		150	°C
Power dissipation ⁽⁴⁾		400	mW
Storage temperature	-65	150	°C

- (1) Stresses beyond those listed under *Absolute Maximum Ratings* may cause permanent damage to the device. These are stress ratings only, which do not imply functional operation of the device at these or any other conditions beyond those indicated under *Recommended Operating Conditions*. Exposure to absolute-maximum-rated conditions for extended periods may affect device reliability.
- (2) All voltages are with respect to the potential at the GND pin.
- (3) If Military/Aerospace specified devices are required, contact the Texas Instruments Sales Office/ Distributors for availability and specifications.
- (4) The part cannot dissipate more than 400 mW.

6.2 ESD Ratings

		VALUE	UNIT
V _(ESD)	Electrostatic discharge	Human-body model (HBM), per ANSI/ESDA/JEDEC JS-001 ⁽¹⁾	±2000
		Charged-device model (CDM), per JEDEC specification JESD22-C101 ⁽²⁾	±1000
		Machine model	±200

- (1) JEDEC document JEP155 states that 500-V HBM allows safe manufacturing with a standard ESD control process.
- (2) JEDEC document JEP157 states that 250-V CDM allows safe manufacturing with a standard ESD control process.

6.3 Recommended Operating Conditions

over operating free-air temperature range (unless otherwise noted)⁽¹⁾⁽²⁾

	MIN	NOM	MAX	UNIT
V _{DD}	2.3		5.5	V
Junction temperature	-40		125	°C
Operating ambient temperature	-40		85	°C

- (1) *Absolute Maximum Ratings* are limits beyond which damage to the device might occur. *Recommended Operating Conditions* are conditions under which operation of the device is ensured. *Recommended Operating Conditions* do not imply ensured performance limits. For verified performance limits and associated test conditions, see *Electrical Characteristics*.
- (2) All voltages are with respect to the potential at the GND pin.

6.4 Thermal Information

THERMAL METRIC ⁽¹⁾		LP3943	UNIT
		RTW (WQFN)	
		24 PINS	
R _{θJA}	Junction-to-ambient thermal resistance	45.0	°C/W
R _{θJC(top)}	Junction-to-case (top) thermal resistance	41.5	°C/W
R _{θJB}	Junction-to-board thermal resistance	22.4	°C/W
ψ _{JT}	Junction-to-top characterization parameter	0.5	°C/W
ψ _{JB}	Junction-to-board characterization parameter	22.5	°C/W
R _{θJC(bot)}	Junction-to-case (bottom) thermal resistance	3.7	°C/W

- (1) For more information about traditional and new thermal metrics, see the *Semiconductor and IC Package Thermal Metrics* application report.

6.5 Electrical Characteristics

Unless otherwise noted, $V_{DD} = 5.5\text{ V}$. Typical values and limits apply for $T_J = 25^\circ\text{C}$. Minimum and maximum limits apply over the entire junction temperature range for operation, $T_J = -40^\circ\text{C}$ to $+125^\circ\text{C}$.⁽¹⁾

PARAMETER		TEST CONDITIONS	MIN	TYP	MAX	UNIT
POWER SUPPLY						
V_{DD}	Supply voltage		2.3	5	5.5	V
I_Q	Supply current	No load		350	550	μA
		Standby		2	5	
ΔI_Q	Additional standby current	$V_{DD} = 5.5\text{ V}$, every LED pin at 4.3 V			2	mA
V_{POR}	Power-On Reset voltage			1.8	1.96	V
t_w	Reset pulse width			10		ns
LED						
V_{IL}	Low level input voltage		-0.5		0.8	V
V_{IH}	High level input voltage		2		5.5	V
I_{OL}	Low level output current ⁽²⁾	$V_{OL} = 0.4\text{ V}$, $V_{DD} = 2.3\text{ V}$	9			mA
		$V_{OL} = 0.4\text{ V}$, $V_{DD} = 3\text{ V}$	12			
		$V_{OL} = 0.4\text{ V}$, $V_{DD} = 5\text{ V}$	15			
		$V_{OL} = 0.7\text{ V}$, $V_{DD} = 2.3\text{ V}$	15			
		$V_{OL} = 0.7\text{ V}$, $V_{DD} = 3\text{ V}$	20			
		$V_{OL} = 0.7\text{ V}$, $V_{DD} = 5\text{ V}$	25			
I_{LEAK}	Input leakage current	$V_{DD} = 3.6\text{ V}$, $V_{IN} = 0\text{ V}$ or V_{DD}	-1		1	μA
$C_{I/O}$	Input/output capacitance	See ⁽³⁾		2.6	5	pF
ALL DIGITAL PINS (EXCEPT SCL AND SDA PINS)						
V_{IL}	LOW level input voltage		-0.5		0.8	V
V_{IH}	HIGH level input voltage		2		5.5	V
I_{LEAK}	Input leakage current		-1		1	μA
C_{IN}	Input capacitance	$V_{IN} = 0\text{ V}$ ⁽³⁾		2.3	5	pF
I²C INTERFACE (SCL AND SDA PINS)						
V_{IL}	LOW level input voltage		-0.5		$0.3V_{DD}$	V
V_{IH}	HIGH level input voltage		$0.7V_{DD}$		5.5	V
V_{OL}	LOW level output voltage		0		$0.2V_{DD}$	V
I_{OL}	LOW level output current	$V_{OL} = 0.4\text{ V}$	3	6.5		mA
f_{CLK}	Clock frequency				400	kHz

- (1) Limits are ensured. All electrical characteristics having room-temperature limits are tested during production with $T_J = 25^\circ\text{C}$. All hot and cold limits are ensured by correlating the electrical characteristics to process and temperature variations and applying statistical process control.
- (2) Each LED pin must not exceed 25 mA and each octal (LED0–LED7; LED8–LED15) must not exceed 100 mA. The package must not exceed a total of 200 mA.
- (3) Verified by design.

6.6 I²C Interface (SCL and SDA Pins) Timing Requirements

 See⁽¹⁾

		MIN	NOM	MAX	UNIT
t_{HOLD}	Hold time repeated START condition	0.6			μs
$t_{\text{CLK-LP}}$	CLK low period	1.3			μs
$t_{\text{CLK-HP}}$	CLK high period	0.6			μs
t_{SU}	Setup time repeated START condition	0.6			μs
$t_{\text{DATA-HOLD}}$	Data hold time	300			ns
$t_{\text{DATA-SU}}$	Data setup time	100			ns
t_{SU}	Setup time for STOP condition	0.6			μs
t_{TRANS}	Maximum pulse width of spikes that must be suppressed by the input filter of both DATA and CLK signals		50		ns

(1) All values verified by design.

6.7 Typical Characteristic

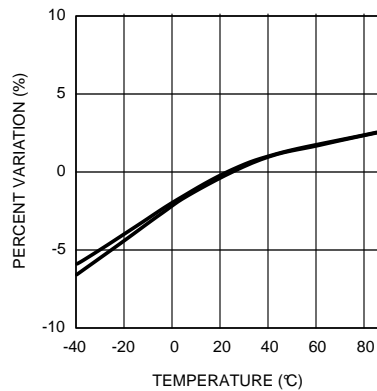

$$T_A = -40^\circ\text{C to } +85^\circ\text{C} \quad V_{\text{DD}} = 2.3 \text{ V to } 3 \text{ V}$$

Figure 1. Frequency vs. Temperature

7 Detailed Description

7.1 Overview

The LP3943 takes incoming data from the baseband controller and feeds them into several registers that control the frequency and the duty cycle of the LEDs. Two prescaler registers and two PWM registers provide two individual rates to dim or blink the LEDs (for more information on these registers, refer to [Table 1](#)). Each LED can be programmed in one of four states: ON, OFF, DIM0 rate, or DIM1 rate. Two read-only registers provide status on all 16 LEDs. The LP3943 can be used to drive RGB LEDs and/or single-color LEDs to create a colorful, entertaining, and informative setting. Alternatively, it can also drive RGB LED as a flashlight. This is particularly suitable for accessory functions in cellular phones and toys. Any LED pins not used to drive LED can be used for general purpose parallel input/output (GPIO) expansion.

The LP3943 is equipped with power-on reset that holds the chip in a reset state until V_{DD} reaches V_{POR} during power up. Once V_{POR} is achieved, the LP3943 comes out of reset and initializes itself to the default state.

To bring the LP3943 into reset, hold the \overline{RST} pin LOW for a period of TW . This puts the chip into its default state. The LP3943 can only be programmed after \overline{RST} signal is HIGH again.

7.2 Functional Block Diagram

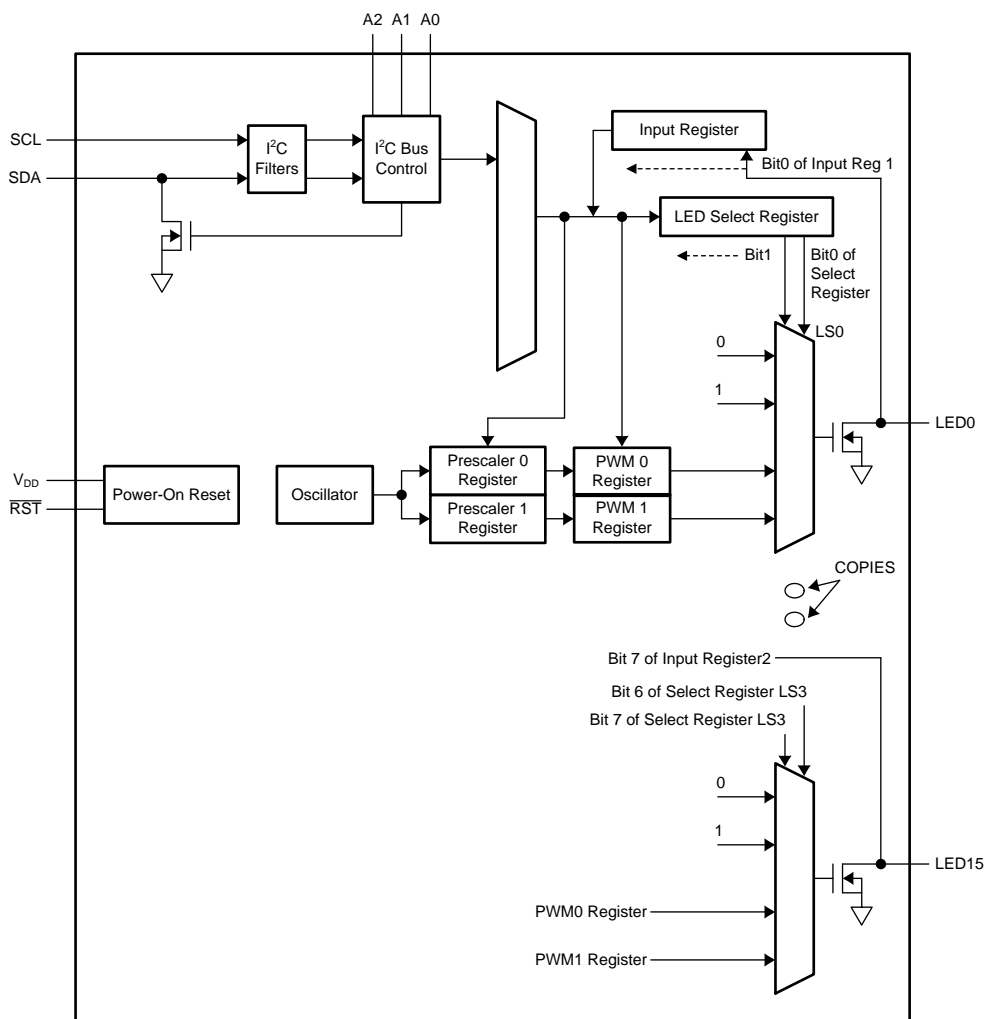

7.3 Feature Description

Some of the features of the LP3943 device are:

1. 16 low-side switches to control the current in 16 strings of LEDs with a maximum of 25 mA per switch or a maximum of 200 mA total.
2. Programmable internal PWM dimming:
 - (a) Duty cycle control (8 bits). Any of the 16 current switches can be mapped to either PWM0 register or PWM1 register. Each register offers 8-bit PWM duty cycle control.
 - (b) PWM Frequency control (8 bits). Any of the 16 current switches can be mapped to either PSC0 register or PSC1 register. Each register offers 8-bit PWM frequency control from 0.625 Hz to 160 Hz.
3. $\overline{\text{RESET}}$ input.
4. Auto increment for I2C writes to reduce number of I2C clock pulses .
5. The LP3943 provides for an externally selectable I2C slave address via the ADR0, ADR1, and ADR2 inputs. See [Figure 4](#).

7.4 Device Functional Modes

1. Output set to high impedance. This is set by programming bits [B0 and B1] to 00 in the LS0, LS1, LS2, or LS3 registers (see [Table 2](#))
2. Output set to ON state (current switch pulls low). This turns the LED on at the full current in the specified current switch bits [B0 and B1] set to 01 in the LS0, LS1, LS2, or LS3 registers (see [Table 12](#)).
3. Output set to toggle at the programmed PWM duty cycle and PWM frequency. This turns on or off the specified current switch at the programmed PWM frequency and duty cycle. Each current switch is mapped to either of the PWM0/PSC0 or PWM1/PSC1 pairs by setting [B0 and B1] to 10 or 11 in the LS0, LS1, LS2, or LS3 registers (see [Table 12](#)).

7.5 Programming

7.5.1 I²C Data Validity

The data on SDA line must be stable during the HIGH period of the clock signal (SCL). In other words, state of the data line can only be changed when CLK is LOW.

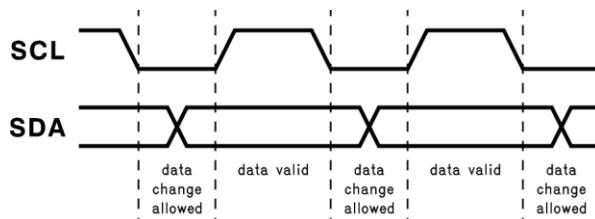

Figure 2. I²C Data Validity

7.5.2 I²C START and STOP Conditions

START and STOP bits classify the beginning and the end of the I²C session. START condition is defined as SDA signal transitioning from HIGH to LOW while SCL line is HIGH. STOP condition is defined as the SDA transitioning from LOW to HIGH while SCL is HIGH. The I²C master always generates START and STOP bits. The I²C bus is considered to be busy after START condition and free after STOP condition. During data transmission, I²C master can generate repeated START conditions. First START and repeated START conditions are equivalent, function-wise.

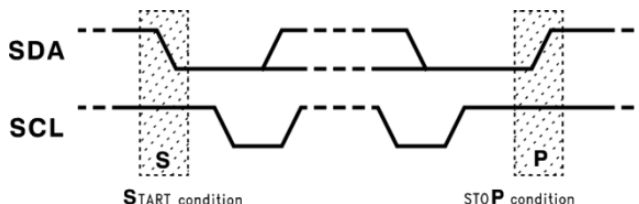

Figure 3. I²C START and STOP Conditions

7.5.3 Transferring Data

Every byte put on the SDA line must be eight bits long with the most significant bit (MSB) being transferred first. The number of bytes that can be transmitted per transfer is unrestricted. Each byte of data has to be followed by an acknowledge bit. The acknowledge related clock pulse is generated by the master. The transmitter releases the SDA line (HIGH) during the acknowledge clock pulse. The receiver must pull down the SDA line during the 9th clock pulse, signifying an acknowledge. A receiver which has been addressed must generate an acknowledge after each byte has been received.

After the START condition, a chip address is sent by the I²C master. This address is seven bits long followed by an eighth bit which is a data direction bit (R/W). The LP3943 hardwires bits 7 to 4 and leaves bits 3 to 1 selectable, as shown in Figure 4. For the eighth bit, a “0” indicates a WRITE and a “1” indicates a READ. The LP3943 supports only a WRITE during chip addressing. The second byte selects the register to which the data is written. The third byte contains data to write to the selected register.

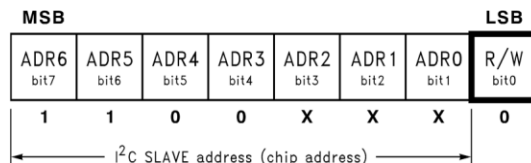

Figure 4. Chip Address Byte

Programming (continued)

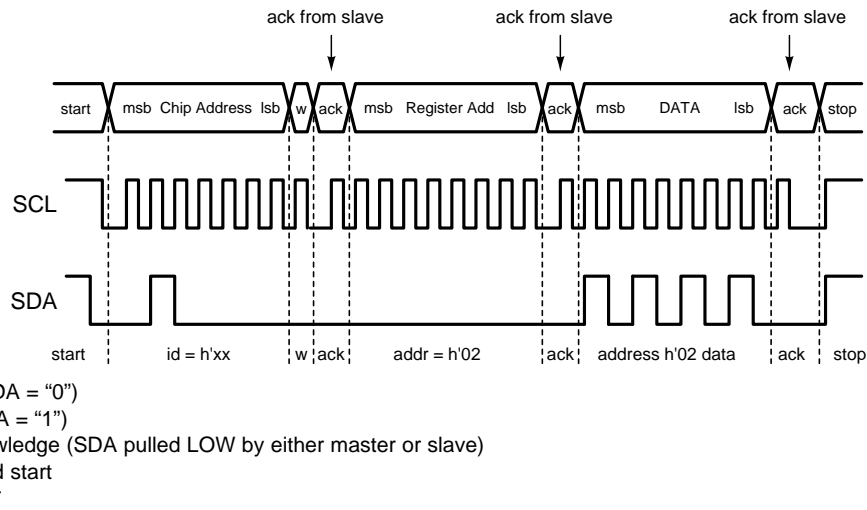

Figure 5. LP3943 Register Write

However, if a READ function is to be accomplished, a WRITE function must precede the READ function, as shown in Figure 6.

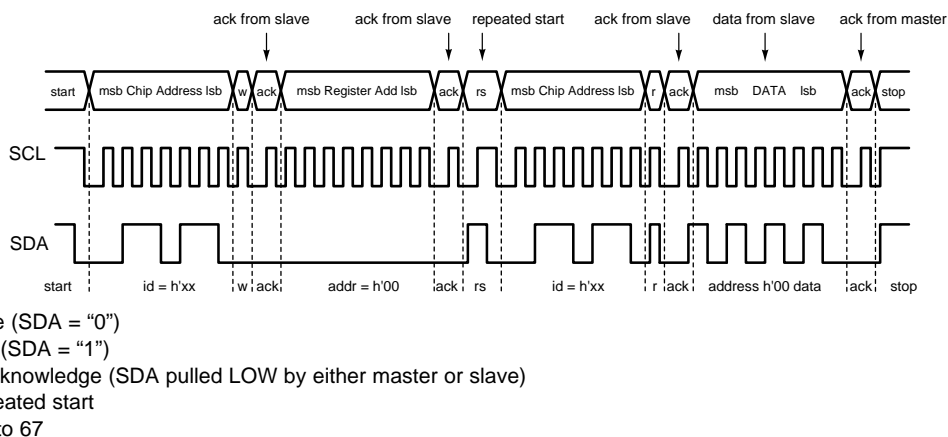

Figure 6. LP3943 Register Read

7.5.4 Auto Increment

Auto increment is a special feature supported by the LP3943 to eliminate repeated chip and register addressing when data are to be written to or read from registers in sequential order. The auto increment bit is inside the register address byte, as shown in Figure 7. Auto increment is enabled when this bit is programmed to "1" and disabled when it is programmed to "0".

Bits 5, 6 and 7 in the register address byte must always be zero.

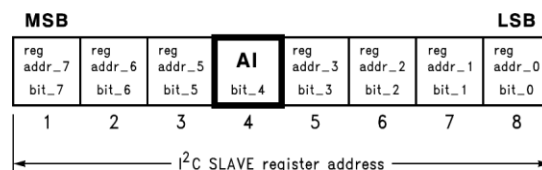

Figure 7. Register Address Byte

Programming (continued)

In the READ mode, when auto increment is enabled, I²C master could receive any number of bytes from LP3943 without selecting chip address and register address again. Every time the I²C master reads a register, the LP3943 increments the register address, and the next data register is read. When I²C master reaches the last register (09H), the register address rolls over to 00H.

In the WRITE mode, when auto increment is enabled, the LP3943 increments the register address every time I²C master writes to register. When the last register (09H register) is reached, the register address rolls over to 02H, not 00H, because the first two registers in LP3943 are read-only registers. It is possible to write to the first two registers independently, and the LP3943 device will acknowledge, but the data is ignored.

If auto increment is disabled, and the I²C master does not change register address, it continues to write data into the same register.

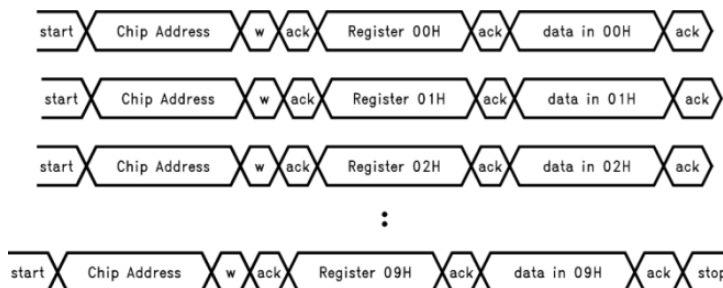

Figure 8. Programming With Auto Increment Disabled (in WRITE Mode)

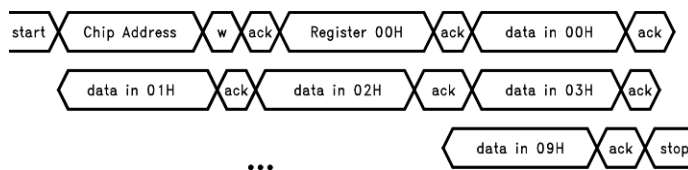

Figure 9. Programming With Auto Increment Enabled (in WRITE Mode)

7.6 Register Maps

Table 1. LP3943 Register Table

Address (Hex)	Register Name	Read/Write	Register Function
0x00	Input 1	Read Only	LED0–7 Input Register
0x01	Input 2	Read Only	LED8–15 Input Register
0x02	PSC0	R/W	Frequency Prescaler 0
0x03	PWM0	R/W	PWM Register 0
0x04	PSC1	R/W	Frequency Prescaler 1
0x05	PWM1	R/W	PWM Register 1
0x06	LS0	R/W	LED0–3 Selector
0x07	LS1	R/W	LED4–7 Selector
0x08	LS2	R/W	LED8–11 Selector
0x09	LS3	R/W	LED12–15 Selector

7.6.1 Binary Format for Input Registers (Read-only)—Address 0x00 and 0x01

Table 2. Address 0x00

Bit #	7	6	5	4	3	2	1	0
Default value	X	X	X	X	X	X	X	X
	LED7	LED6	LED5	LED4	LED3	LED2	LED1	LED0

Table 3. Address 0x01

Bit #	7	6	5	4	3	2	1	0
Default value	X	X	X	X	X	X	X	X
	LED15	LED14	LED13	LED12	LED11	LED10	LED9	LED8

7.6.2 Binary Format for Frequency Prescaler and PWM Registers — Address 0x02 to 0x05

Table 4. Address 0x02 (PSC0)

Bit #	7	6	5	4	3	2	1	0
Default value	0	0	0	0	0	0	0	0

Table 5. Address 0x03 (PWM0)

Bit #	7	6	5	4	3	2	1	0
Default value	1	0	0	0	0	0	0	0

Table 6. Address 0x04 (PSC1)

Bit #	7	6	5	4	3	2	1	0
Default value	0	0	0	0	0	0	0	0

Table 7. Address 0x05 (PWM1)

Bit #	7	6	5	4	3	2	1	0
Default value	1	0	0	0	0	0	0	0

7.6.3 Binary Format for Selector Registers — Address 0x06 to 0x09
Table 8. Address 0x06 (LS0)

Bit #	7	6	5	4	3	2	1	0
Default value	0	0	0	0	0	0	0	0
	B1	B0	B1	B0	B1	B0	B1	B0
	LED3		LED2		LED1		LED0	

Table 9. Address 0x07 (LS1)

Bit #	7	6	5	4	3	2	1	0
Default value	0	0	0	0	0	0	0	0
	B1	B0	B1	B0	B1	B0	B1	B0
	LED7		LED6		LED5		LED4	

Table 10. Address 0x08 (LS2)

Bit #	7	6	5	4	3	2	1	0
Default value	0	0	0	0	0	0	0	0
	B1	B0	B1	B0	B1	B0	B1	B0
	LED11		LED10		LED9		LED8	

Table 11. Address 0x09 (LS3)

Bit #	7	6	5	4	3	2	1	0
Default value	0	0	0	0	0	0	0	0
	B1	B0	B1	B0	B1	B0	B1	B0
	LED15		LED14		LED13		LED12	

Table 12. LED States With Respect To Values in B1 and B0

B1	B0	Function
0	0	Output Hi-Z (LED off)
0	1	Output LOW (LED on)
1	0	Output dims (DIM0 rate)
1	1	Output dims (DIM1 rate)

Programming Example:

- Dim LEDs 0 to 7 at 1 Hz at 25% duty cycle
- Dim LEDs 8 to 12 at 5 Hz at 50% duty cycle
- Set LEDs 13, 14 and 15 off
- Step 1: Set PSC0 to achieve DIM0 of 1 s
- Step 2: Set PWM0 duty cycle to 25%
- Step 3: Set PSC1 to achieve DIM1 of 0.2 s
- Step 4: Set PWM1 duty cycle to 50%
- Step 5: Set LEDs 13, 14 and 15 off by loading the data into LS3 register
- Step 6: Set LEDs 0 to 7 to point to DIM0
- Step 7: Set LEDs 8 to 12 to point to DIM1

Table 13. Programming Details

STEP	DESCRIPTION	REGISTER NAME	SET TO (HEX)
1	Set DIM0 = 1 s $1 = (\text{PSC0} + 1)/160$ PSC0 = 159	PSC0	0x09F
2	Set duty cycle to 25% Duty Cycle = PWM0/256 PWM0 = 64	PWM0	0x40
3	Set DIM1 = 0.2s $0.2 = (\text{PSC1} + 1)/160$ PSC1 = 31	PSC1	0x1F
4	Set duty cycle to 50% Duty Cycle = PWM1/256 PWM1 = 128	PWM1	0x80
5	LEDs 13, 14 and 15 off Output = HIGH	LS3	0x03
6	LEDs 0 to 7 Output = DIM0	LS0, LS1	LS0 = 0xAA LS1 = 0xAA
7	LEDs 8 to 12 Output = DIM1	LS2, LS3	LS2 = 0xFF LS3 = 0x03

8 Application and Implementation

NOTE

Information in the following applications sections is not part of the TI component specification, and TI does not warrant its accuracy or completeness. TI's customers are responsible for determining suitability of components for their purposes. Customers should validate and test their design implementation to confirm system functionality.

8.1 Application Information

The LP3943 is a 16-channel LED controller which has 16 low-side current switches. Each switch can control the LED current in its respective LED or LEDs by modulating its duty cycle and frequency.

8.2 Typical Application

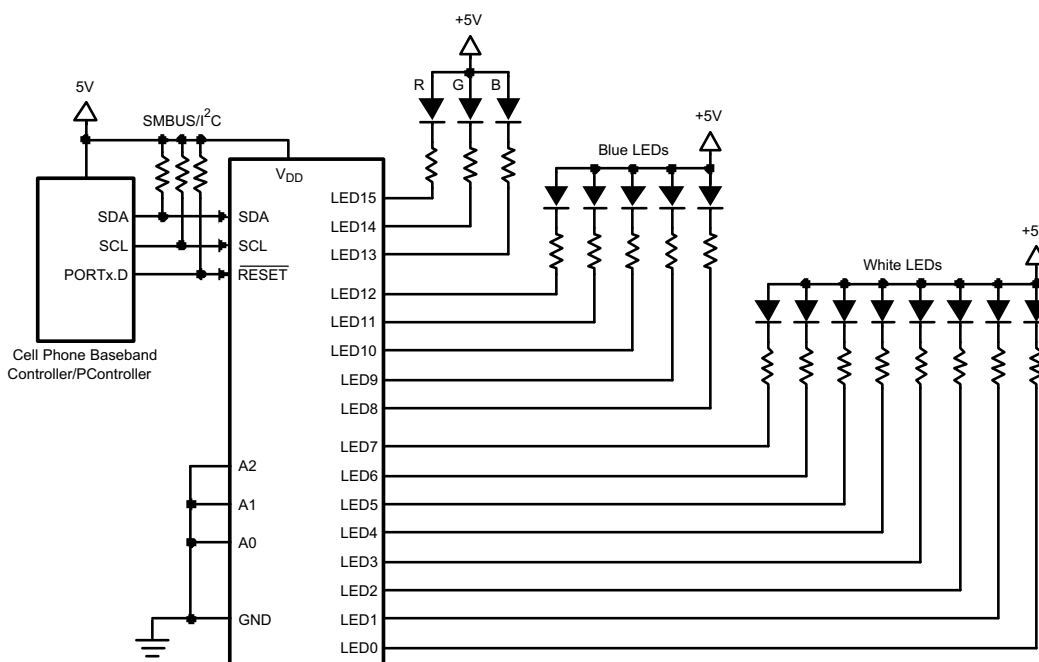

Figure 10. LP3943 Typical Application

8.2.1 Design Requirements

For typical RGB LED light-driver applications, use the parameters listed in [Table 14](#).

Table 14. Design Parameters

DESIGN PARAMETER	EXAMPLE VALUE
Minimum input voltage	2.3 V
Typical output voltage	5 V
Output current	20 mA

8.2.2 Detailed Design Procedure

8.2.2.1 Reducing I_Q When LEDs are OFF

In many applications, the LEDs and the LP3943 share the same V_{DD} , as shown in Figure 10. When the LEDs are off, the LED pins are at a lower potential than V_{DD} , causing extra supply current (ΔI_Q). To minimize this current, consider keeping the LED pins at a voltage equal to or greater than V_{DD} .

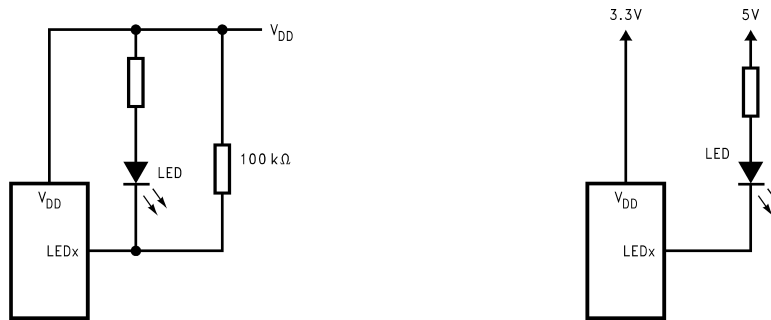

Figure 11. Methods to Reduce I_Q When LEDs are in OFF State

8.2.3 Application Curve

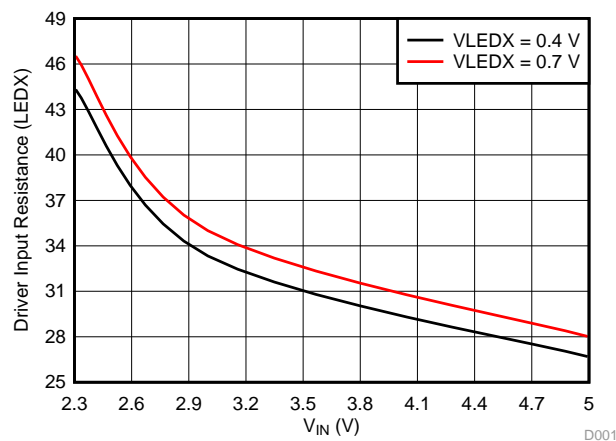

Figure 12. Typical LED Switch Resistance

8.3 System Examples

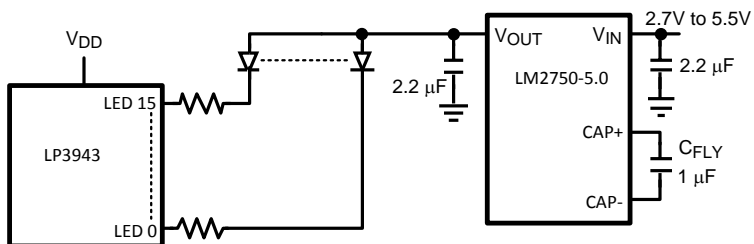

Figure 13. LP3943 With 5-V Booster

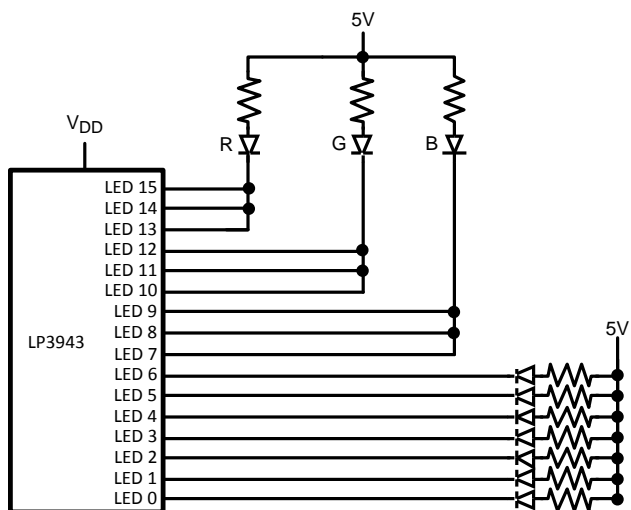

Figure 14. LP3943 Driving RGB LED as a Flash

9 Power Supply Recommendations

The LP3943 is designed to be powered from a 2.3-V minimum to a 5.5-V maximum supply input.

10 Layout

10.1 Layout Guidelines

The LP3943 layout is not critical, but TI recommends providing a noise-free supply input at V_{DD} . This typically would require a 1- μ F capacitor placed close to the VDD pin and ground.

10.2 Layout Example

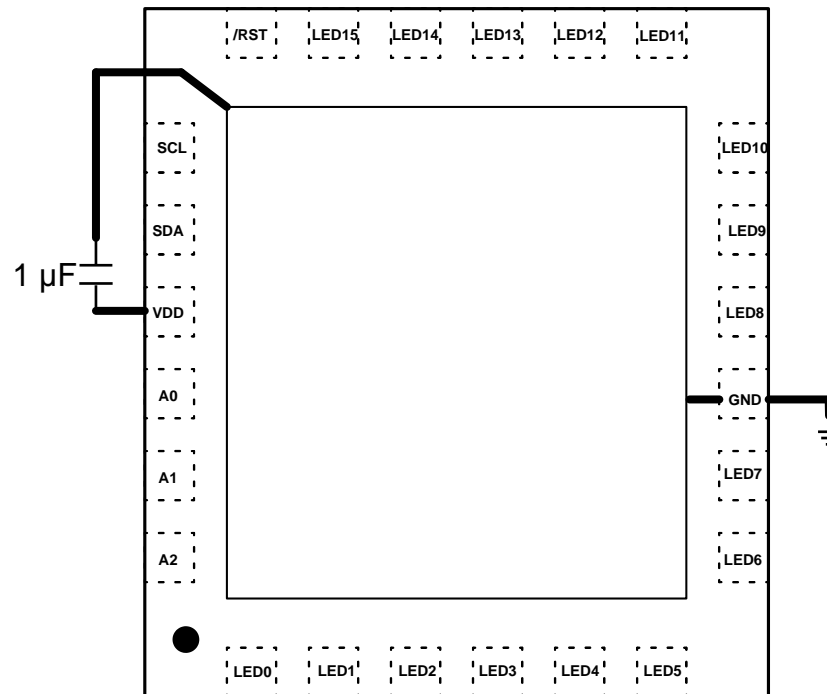

Figure 15. LP3943 Layout Example

11 Device and Documentation Support

11.1 Receiving Notification of Documentation Updates

To receive notification of documentation updates, navigate to the device product folder on ti.com. In the upper right corner, click on *Alert me* to register and receive a weekly digest of any product information that has changed. For change details, review the revision history included in any revised document.

11.2 Community Resources

The following links connect to TI community resources. Linked contents are provided "AS IS" by the respective contributors. They do not constitute TI specifications and do not necessarily reflect TI's views; see TI's [Terms of Use](#).

TI E2E™ Online Community *TI's Engineer-to-Engineer (E2E) Community*. Created to foster collaboration among engineers. At e2e.ti.com, you can ask questions, share knowledge, explore ideas and help solve problems with fellow engineers.

Design Support *TI's Design Support* Quickly find helpful E2E forums along with design support tools and contact information for technical support.

11.3 Trademarks

E2E is a trademark of Texas Instruments.
All other trademarks are the property of their respective owners.

11.4 Electrostatic Discharge Caution



These devices have limited built-in ESD protection. The leads should be shorted together or the device placed in conductive foam during storage or handling to prevent electrostatic damage to the MOS gates.

11.5 Glossary

[SLYZ022](#) — *TI Glossary*.

This glossary lists and explains terms, acronyms, and definitions.

12 Mechanical, Packaging, and Orderable Information

The following pages include mechanical, packaging, and orderable information. This information is the most current data available for the designated devices. This data is subject to change without notice and revision of this document. For browser-based versions of this data sheet, refer to the left-hand navigation.

PACKAGING INFORMATION

Orderable Device	Status (1)	Package Type	Package Drawing	Pins	Package Qty	Eco Plan (2)	Lead/Ball Finish (6)	MSL Peak Temp (3)	Op Temp (°C)	Device Marking (4/5)	Samples
LP3943ISQ	NRND	WQFN	RTW	24	1000	TBD	Call TI	Call TI	-40 to 85	3943SQ	
LP3943ISQ/NOPB	ACTIVE	WQFN	RTW	24	1000	Green (RoHS & no Sb/Br)	CU SN	Level-1-260C-UNLIM	-40 to 85	3943SQ	Samples
LP3943ISQX/NOPB	ACTIVE	WQFN	RTW	24	4500	Green (RoHS & no Sb/Br)	CU SN	Level-1-260C-UNLIM	-40 to 85	3943SQ	Samples

(1) The marketing status values are defined as follows:

ACTIVE: Product device recommended for new designs.

LIFEBUY: TI has announced that the device will be discontinued, and a lifetime-buy period is in effect.

NRND: Not recommended for new designs. Device is in production to support existing customers, but TI does not recommend using this part in a new design.

PREVIEW: Device has been announced but is not in production. Samples may or may not be available.

OBSOLETE: TI has discontinued the production of the device.

(2) Eco Plan - The planned eco-friendly classification: Pb-Free (RoHS), Pb-Free (RoHS Exempt), or Green (RoHS & no Sb/Br) - please check <http://www.ti.com/productcontent> for the latest availability information and additional product content details.

TBD: The Pb-Free/Green conversion plan has not been defined.

Pb-Free (RoHS): TI's terms "Lead-Free" or "Pb-Free" mean semiconductor products that are compatible with the current RoHS requirements for all 6 substances, including the requirement that lead not exceed 0.1% by weight in homogeneous materials. Where designed to be soldered at high temperatures, TI Pb-Free products are suitable for use in specified lead-free processes.

Pb-Free (RoHS Exempt): This component has a RoHS exemption for either 1) lead-based flip-chip solder bumps used between the die and package, or 2) lead-based die adhesive used between the die and leadframe. The component is otherwise considered Pb-Free (RoHS compatible) as defined above.

Green (RoHS & no Sb/Br): TI defines "Green" to mean Pb-Free (RoHS compatible), and free of Bromine (Br) and Antimony (Sb) based flame retardants (Br or Sb do not exceed 0.1% by weight in homogeneous material)

(3) MSL, Peak Temp. - The Moisture Sensitivity Level rating according to the JEDEC industry standard classifications, and peak solder temperature.

(4) There may be additional marking, which relates to the logo, the lot trace code information, or the environmental category on the device.

(5) Multiple Device Markings will be inside parentheses. Only one Device Marking contained in parentheses and separated by a "~" will appear on a device. If a line is indented then it is a continuation of the previous line and the two combined represent the entire Device Marking for that device.

(6) Lead/Ball Finish - Orderable Devices may have multiple material finish options. Finish options are separated by a vertical ruled line. Lead/Ball Finish values may wrap to two lines if the finish value exceeds the maximum column width.

Important Information and Disclaimer: The information provided on this page represents TI's knowledge and belief as of the date that it is provided. TI bases its knowledge and belief on information provided by third parties, and makes no representation or warranty as to the accuracy of such information. Efforts are underway to better integrate information from third parties. TI has taken and

continues to take reasonable steps to provide representative and accurate information but may not have conducted destructive testing or chemical analysis on incoming materials and chemicals. TI and TI suppliers consider certain information to be proprietary, and thus CAS numbers and other limited information may not be available for release.

In no event shall TI's liability arising out of such information exceed the total purchase price of the TI part(s) at issue in this document sold by TI to Customer on an annual basis.

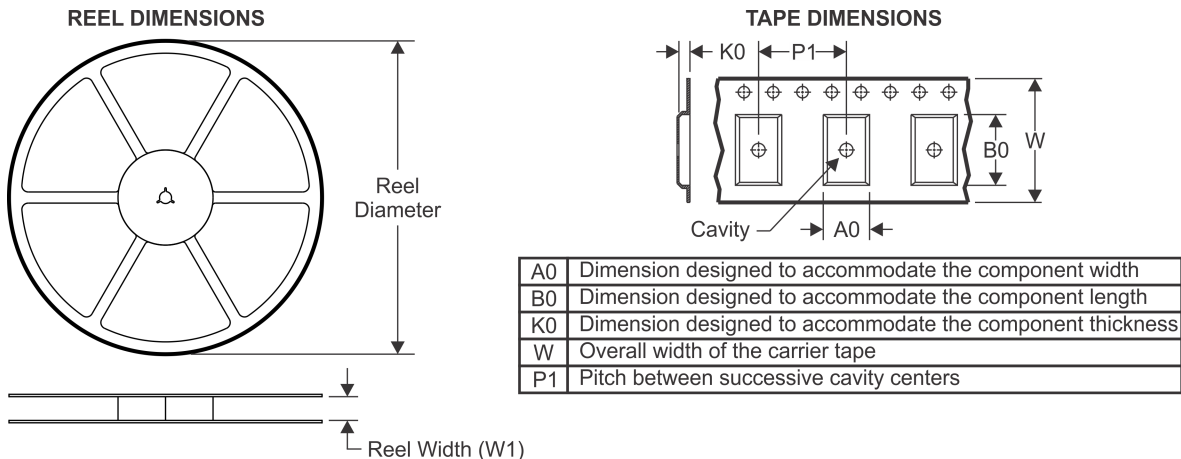
TAPE AND REEL INFORMATION

QUADRANT ASSIGNMENTS FOR PIN 1 ORIENTATION IN TAPE

*All dimensions are nominal

Device	Package Type	Package Drawing	Pins	SPQ	Reel Diameter (mm)	Reel Width W1 (mm)	A0 (mm)	B0 (mm)	K0 (mm)	P1 (mm)	W (mm)	Pin1 Quadrant
LP3943ISQ	WQFN	RTW	24	1000	178.0	12.4	4.3	4.3	1.3	8.0	12.0	Q1
LP3943ISQ/NOPB	WQFN	RTW	24	1000	178.0	12.4	4.3	4.3	1.3	8.0	12.0	Q1
LP3943ISQX/NOPB	WQFN	RTW	24	4500	330.0	12.4	4.3	4.3	1.3	8.0	12.0	Q1

TAPE AND REEL BOX DIMENSIONS

*All dimensions are nominal

Device	Package Type	Package Drawing	Pins	SPQ	Length (mm)	Width (mm)	Height (mm)
LP3943ISQ	WQFN	RTW	24	1000	210.0	185.0	35.0
LP3943ISQ/NOPB	WQFN	RTW	24	1000	210.0	185.0	35.0
LP3943ISQX/NOPB	WQFN	RTW	24	4500	367.0	367.0	35.0

RTW0024C

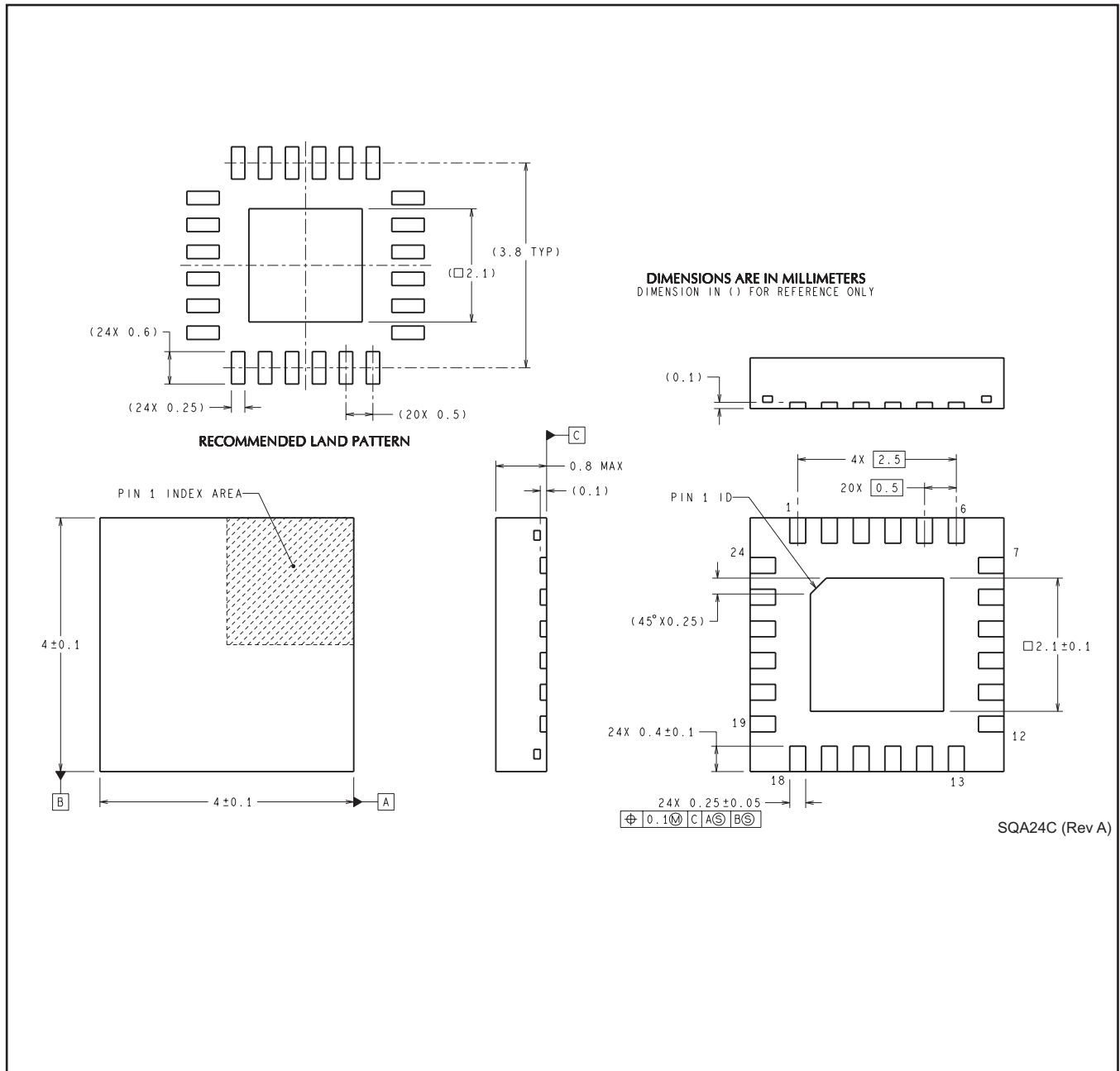

IMPORTANT NOTICE

Texas Instruments Incorporated and its subsidiaries (TI) reserve the right to make corrections, enhancements, improvements and other changes to its semiconductor products and services per JESD46, latest issue, and to discontinue any product or service per JESD48, latest issue. Buyers should obtain the latest relevant information before placing orders and should verify that such information is current and complete. All semiconductor products (also referred to herein as "components") are sold subject to TI's terms and conditions of sale supplied at the time of order acknowledgment.

TI warrants performance of its components to the specifications applicable at the time of sale, in accordance with the warranty in TI's terms and conditions of sale of semiconductor products. Testing and other quality control techniques are used to the extent TI deems necessary to support this warranty. Except where mandated by applicable law, testing of all parameters of each component is not necessarily performed.

TI assumes no liability for applications assistance or the design of Buyers' products. Buyers are responsible for their products and applications using TI components. To minimize the risks associated with Buyers' products and applications, Buyers should provide adequate design and operating safeguards.

TI does not warrant or represent that any license, either express or implied, is granted under any patent right, copyright, mask work right, or other intellectual property right relating to any combination, machine, or process in which TI components or services are used. Information published by TI regarding third-party products or services does not constitute a license to use such products or services or a warranty or endorsement thereof. Use of such information may require a license from a third party under the patents or other intellectual property of the third party, or a license from TI under the patents or other intellectual property of TI.

Reproduction of significant portions of TI information in TI data books or data sheets is permissible only if reproduction is without alteration and is accompanied by all associated warranties, conditions, limitations, and notices. TI is not responsible or liable for such altered documentation. Information of third parties may be subject to additional restrictions.

Resale of TI components or services with statements different from or beyond the parameters stated by TI for that component or service voids all express and any implied warranties for the associated TI component or service and is an unfair and deceptive business practice. TI is not responsible or liable for any such statements.

Buyer acknowledges and agrees that it is solely responsible for compliance with all legal, regulatory and safety-related requirements concerning its products, and any use of TI components in its applications, notwithstanding any applications-related information or support that may be provided by TI. Buyer represents and agrees that it has all the necessary expertise to create and implement safeguards which anticipate dangerous consequences of failures, monitor failures and their consequences, lessen the likelihood of failures that might cause harm and take appropriate remedial actions. Buyer will fully indemnify TI and its representatives against any damages arising out of the use of any TI components in safety-critical applications.

In some cases, TI components may be promoted specifically to facilitate safety-related applications. With such components, TI's goal is to help enable customers to design and create their own end-product solutions that meet applicable functional safety standards and requirements. Nonetheless, such components are subject to these terms.

No TI components are authorized for use in FDA Class III (or similar life-critical medical equipment) unless authorized officers of the parties have executed a special agreement specifically governing such use.

Only those TI components which TI has specifically designated as military grade or "enhanced plastic" are designed and intended for use in military/aerospace applications or environments. Buyer acknowledges and agrees that any military or aerospace use of TI components which have **not** been so designated is solely at the Buyer's risk, and that Buyer is solely responsible for compliance with all legal and regulatory requirements in connection with such use.

TI has specifically designated certain components as meeting ISO/TS16949 requirements, mainly for automotive use. In any case of use of non-designated products, TI will not be responsible for any failure to meet ISO/TS16949.

Products

Audio	www.ti.com/audio
Amplifiers	amplifier.ti.com
Data Converters	dataconverter.ti.com
DLP® Products	www.dlp.com
DSP	dsp.ti.com
Clocks and Timers	www.ti.com/clocks
Interface	interface.ti.com
Logic	logic.ti.com
Power Mgmt	power.ti.com
Microcontrollers	microcontroller.ti.com
RFID	www.ti-rfid.com
OMAP Applications Processors	www.ti.com/omap
Wireless Connectivity	www.ti.com/wirelessconnectivity

Applications

Automotive and Transportation	www.ti.com/automotive
Communications and Telecom	www.ti.com/communications
Computers and Peripherals	www.ti.com/computers
Consumer Electronics	www.ti.com/consumer-apps
Energy and Lighting	www.ti.com/energy
Industrial	www.ti.com/industrial
Medical	www.ti.com/medical
Security	www.ti.com/security
Space, Avionics and Defense	www.ti.com/space-avionics-defense
Video and Imaging	www.ti.com/video

TI E2E Community

e2e.ti.com

Looking for pricing, stock, or lifecycle information?

Click below to explore more details on WIN SOURCE:

 [View LP3943ISQX/NOPB on WIN SOURCE](#)

 [Texas Instruments](#) Information

Optimize Your Supply Chain with WIN SOURCE Solutions

-  Global Sourcing Solution
-  Obsolete Management
-  Cost Control Management
-  Shortage Management
-  Alternative Solution
-  Excess Inventory Management