



LOW SKEW, DUAL, 1-TO-5, DIFFERENTIAL-TO-2.5V, 3.3V LVPECL/ECL FANOUT BUFFER

ICS853210

GENERAL DESCRIPTION



The ICS853210 is a low skew, high performance dual 1-to-5 Differential-to-2.5V/3.3V LVPECL/ECL Fanout Buffer and a member of the HiPerClockSM family of High Performance Clock Solutions from IDT. The ICS853210 is characterized to operate from either a 2.5V or a 3.3V power supply. Guaranteed output and part-to-part skew characteristics make the ICS853210 ideal for those clock distribution applications demanding well defined performance and repeatability.

FEATURES

- Two differential 2.5V/3.3V LVPECL / ECL bank outputs
- Two differential clock input pairs
- PCLKx, nPCLKx pairs can accept the following differential input levels: LVPECL, LVDS, CML, SSTL
- Maximum output frequency: >3GHz
- Translates any single ended input signal to 3.3V LVPECL levels with resistor bias on nPCLKx input
- Output skew: 13ps (typical)
- Part-to-part skew: 85ps (typical)
- Propagation delay: 485ps (typical)
- LVPECL mode operating voltage supply range: $V_{CC} = 2.375V$ to $3.8V$, $V_{EE} = 0V$
- ECL mode operating voltage supply range: $V_{CC} = 0V$, $V_{EE} = -2.375V$ to $-3.8V$
- -40°C to 85°C ambient operating temperature
- Available in both standard (RoHS 5) and lead-free (RoHS 6) packages

BLOCK DIAGRAM

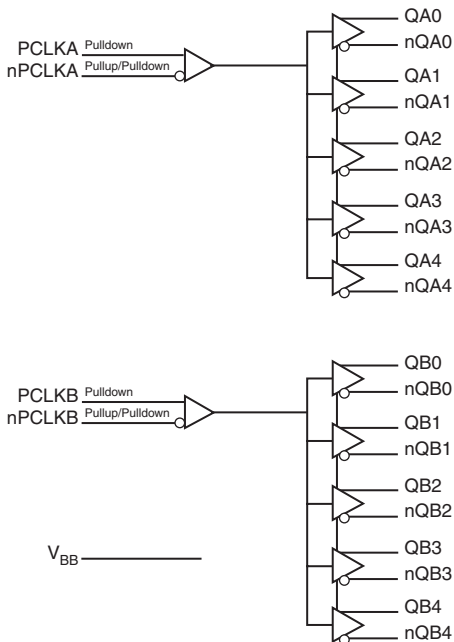

PIN ASSIGNMENT

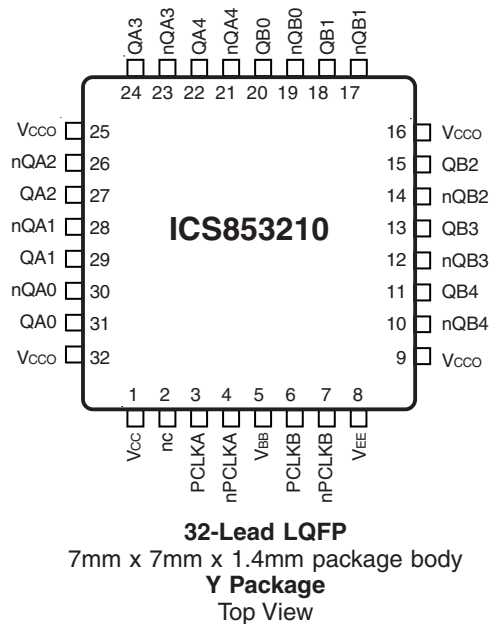

TABLE 1. PIN DESCRIPTIONS

Number	Name	Type		Description
1	V _{CC}	Power		Positive supply pin.
2	nc	Unused		No connect.
3	PCLKA	Input	Pulldown	Non-inverting differential clock input.
4	nPCLKA	Input	Pullup/ Pulldown	Clock input. V _{CC} /2 default when left floating.
5	V _{BB}	Output		Bias voltage.
6	PCLKB	Input	Pulldown	Non-inverting differential clock input.
7	nPCLKB	Input	Pullup/ Pulldown	Clock input. V _{CC} /2 default when left floating.
8	V _{EE}	Power		Negative supply pin.
9, 25, 32	V _{CCO}	Power		Output supply pins.
10, 11	nQB4, QB4	Output		Differential output pair. LVPECL interface levels.
12, 13	nQB3, QB3	Output		Differential output pair. LVPECL interface levels.
14, 15	nQB2, QB2	Output		Differential output pair. LVPECL interface levels.
17, 18	nQB1, QB1	Output		Differential output pair. LVPECL interface levels.
19, 20	nQB0, QB0	Output		Differential output pair. LVPECL interface levels.
21, 22	nQA4, QA4	Output		Differential output pair. LVPECL interface levels.
23, 24	nQA3, QA3	Output		Differential output pair. LVPECL interface levels.
26, 27	nQA2, QA2	Output		Differential output pair. LVPECL interface levels.
28, 29	nQA1, QA1	Output		Differential output pair. LVPECL interface levels.
30, 31	nQA0, QA0	Output		Differential output pair. LVPECL interface levels.

NOTE: *Pullup* and *Pulldown* refer to internal input resistors. See Table 2, Pin Characteristics, for typical values.

TABLE 2. PIN CHARACTERISTICS

Symbol	Parameter	Test Conditions	Minimum	Typical	Maximum	Units
R _{PULLDOWN}	Input Pulldown Resistor			75		kΩ
R _{VCC/2}	Pullup/Pulldown Resistors			50		kΩ

TABLE 3. CLOCK INPUT FUNCTION TABLE

Inputs		Outputs		Input to Output Mode	Polarity
PCLKA or PCLKB	nPCLKA or nPCLKB	QA0:QA4, QB0:QB4	nQA0:nQA4, nQB0:nQB4		
0	1	LOW	HIGH	Differential to Differential	Non Inverting
1	0	HIGH	LOW	Differential to Differential	Non Inverting
0	Biased; NOTE 1	LOW	HIGH	Single Ended to Differential	Non Inverting
1	Biased; NOTE 1	HIGH	LOW	Single Ended to Differential	Non Inverting
Biased; NOTE 1	0	HIGH	LOW	Single Ended to Differential	Inverting
Biased; NOTE 1	1	LOW	HIGH	Single Ended to Differential	Inverting

NOTE 1: Please refer to the Application Information, "Wiring the Differential Input to Accept Single Ended Levels".

ABSOLUTE MAXIMUM RATINGS

Supply Voltage, V_{CC}	4.6V (LVPECL mode, $V_{EE} = 0$)
Negative Supply Voltage, V_{EE}	-4.6V (ECL mode, $V_{CC} = 0$)
Inputs, V_I (LVPECL mode)	-0.5V to $V_{CC} + 0.5V$
Inputs, V_I (ECL mode)	0.5V to $V_{EE} - 0.5V$
Outputs, I_O	
Continuous Current	50mA
Surge Current	100mA
V_{BB} Sink/Source, I_{BB}	$\pm 0.5mA$
Operating Temperature Range, T_A	-40°C to +85°C
Storage Temperature, T_{STG}	-65°C to 150°C
Package Thermal Impedance, θ_{JA} (Junction-to-Ambient)	47.9°C/W (0 lfpm)

NOTE: Stresses beyond those listed under Absolute Maximum Ratings may cause permanent damage to the device. These ratings are stress specifications only. Functional operation of product at these conditions or any conditions beyond those listed in the *DC Characteristics* or *AC Characteristics* is not implied. Exposure to absolute maximum rating conditions for extended periods may affect product reliability.

TABLE 4A. POWER SUPPLY DC CHARACTERISTICS, $V_{CC} = 3.3V$; $V_{EE} = 0V$

Symbol	Parameter	Test Conditions	Minimum	Typical	Maximum	Units
V_{CC}	Positive Supply Voltage		2.375	3.3	3.8	V
I_{EE}	Power Supply Current				80	mA

TABLE 4B. LVPECL DC CHARACTERISTICS, $V_{CC} = 3.3V$; $V_{EE} = 0V$

Symbol	Parameter	-40°C			25°C			85°C			Units
		Min	Typ	Max	Min	Typ	Max	Min	Typ	Max	
V_{OH}	Output High Voltage; NOTE 1	2.175	2.275	2.38	2.225	2.295	2.37	2.295	2.33	2.365	V
V_{OL}	Output Low Voltage; NOTE 1	1.405	1.545	1.68	1.425	1.52	1.615	1.44	1.535	1.63	V
V_{IH}	Input High Voltage(Single-Ended)	2.075		2.36	2.075		2.36	2.075		2.36	V
V_{IL}	Input Low Voltage(Single-Ended)	1.43		1.765	1.43		1.765	1.43		1.765	V
V_{BB}	Output Voltage Reference; NOTE 2	1.86		1.98	1.86		1.98	1.86		1.98	V
V_{PP}	Peak-to-Peak Input Voltage	150	800	1200	150	800	1200	150	800	1200	mV
V_{CMR}	Input High Voltage Common Mode Range; NOTE 3, 4	1.2		3.3	1.2		3.3	1.2		3.3	V
I_{IH}	Input High Current	PCLK0, PCLK1 nPCLK0, nPCLK1		150			150			150	μA
I_{IL}	Input Low Current	PCLK0, PCLK1		-10			-10			-10	μA
		nPCLK0, nPCLK1		-150			-150			-150	μA

Input and output parameters vary 1:1 with V_{CC} . V_{EE} can vary +0.925V to -0.5V.

NOTE 1: Outputs terminated with 50 Ω to $V_{CC} - 2V$.

NOTE 2: Single-ended input operation is limited. $V_{CC} \geq 3V$ in LVPECL mode.

NOTE 3: Common mode voltage is defined as V_{IH} .

NOTE 4: For single-ended applications, the maximum input voltage for PCLK0, nPCLK0 and PCLK1, nPCLK1 is $V_{CC} + 0.3V$.

TABLE 4C. LVPECL DC CHARACTERISTICS, $V_{CC} = 2.5V$; $V_{EE} = 0V$

Symbol	Parameter	-40°C			25°C			85°C			Units
		Min	Typ	Max	Min	Typ	Max	Min	Typ	Max	
V_{OH}	Output High Voltage; NOTE 1	1.375	1.475	1.58	1.425	1.495	1.57	1.495	1.53	1.565	V
V_{OL}	Output Low Voltage; NOTE 1	0.605	0.745	0.88	0.625	0.72	0.815	0.64	0.735	0.83	V
V_{IH}	Input High Voltage(Single-Ended)	1.275		1.56	1.275		1.56	1.275		-0.83	V
V_{IL}	Input Low Voltage(Single-Ended)	0.63		0.965	0.63		0.965	0.63		0.965	V
V_{PP}	Peak-to-Peak Input Voltage	150	800	1200	150	800	1200	150	800	1200	mV
V_{CMR}	Input High Voltage Common Mode Range; NOTE 2, 3	1.2		2.5	1.2		2.5	1.2		2.5	V
I_{IH}	Input High Current	PCLK0, PCLK1 nPCLK0, nPCLK1		150			150			150	μA
I_{IL}	Input Low Current	PCLK0, PCLK1		-10			-10				μA
		nPCLK0, nPCLK1		-150			-150				μA

Input and output parameters vary 1:1 with V_{CC} . V_{EE} can vary +0.925V to -0.5V.

NOTE 1: Outputs terminated with 50Ω to $V_{CCO} - 2V$.

NOTE 2: Common mode voltage is defined as V_{IH} .

NOTE 3: For single-ended applications, the maximum input voltage for PCLK0, nPCLK0 and PCLK1, nPCLK1 is $V_{CC} + 0.3V$.

TABLE 4D. ECL DC CHARACTERISTICS, $V_{CC} = 0V$; $V_{EE} = -2.375$ TO $-3.8V$

Symbol	Parameter	-40°C			25°C			85°C			Units
		Min	Typ	Max	Min	Typ	Max	Min	Typ	Max	
V_{OH}	Output High Voltage; NOTE 1	-1.125	-1.025	-0.92	-1.075	-1.005	-0.93	-1.005	-0.97	-0.935	V
V_{OL}	Output Low Voltage; NOTE 1	-1.895	-1.755	-1.62	-1.875	-1.78	-1.685	-1.86	-1.765	-1.67	V
V_{IH}	Input High Voltage(Single-Ended)	-1.225		-0.94	-1.225		-0.94	-1.225		-0.94	V
V_{IL}	Input Low Voltage(Single-Ended)	-1.87		-1.535	-1.87		-1.535	-1.87		-1.535	V
V_{BB}	Output Voltage Reference; NOTE 2	-1.44		-1.32	-1.44		-1.32	-1.44		-1.32	V
V_{PP}	Peak-to-Peak Input Voltage	150	800	1200	150	800	1200	150	800	1200	mV
V_{CMR}	Input High Voltage Common Mode Range; NOTE 3, 4	$V_{EE}+1.2V$		0	$V_{EE}+1.2V$		0	$V_{EE}+1.2V$		0	V
I_{IH}	Input High Current	PCLK0, PCLK1 nPCLK0, nPCLK1		150			150			150	μA
I_{IL}	Input Low Current	PCLK0, PCLK1		-10			-10				μA
		nPCLK0, nPCLK1		-150			-150				μA

Input and output parameters vary 1:1 with V_{CC} . V_{EE} can vary +0.925V to -0.5V.

NOTE 1: Outputs terminated with 50Ω to $V_{CCO} - 2V$.

NOTE 2: Single-ended input operation is limited. $V_{CC} \geq 3V$ in LVPECL mode.

NOTE 3: Common mode voltage is defined as V_{IH} .

NOTE 4: For single-ended applications, the maximum input voltage for PCLK0, nPCLK0 and PCLK1, nPCLK1 is $V_{CC} + 0.3V$.

TABLE 5. AC CHARACTERISTICS, $V_{CC} = 0V$; $V_{EE} = -2.375$ TO $-3.8V$ OR $V_{CC} = 2.375$ TO $3.8V$; $V_{EE} = 0V$

Symbol	Parameter	-40°C			25°C			85°C			Units
		Min	Typ	Max	Min	Typ	Max	Min	Typ	Max	
f_{MAX}	Output Frequency		>3			>3			>3		GHz
$t_{P_{LH}}$	Propagation Delay, Low-to-High; NOTE 1	415	470	520	430	485	545	435	515	585	ps
$t_{P_{HL}}$	Propagation Delay, High-to-Low; NOTE 1										
	@ 2.5V	400	470	540	425	490	550	445	515	585	ps
$t_{sk(o)}$	Output Skew; NOTE 2, 4		13	25		13	25		13	25	ps
$t_{sk(pp)}$	Part-to-Part Skew; NOTE 3, 4		85	160		85	160		85	160	ps
t_R/t_F	Output Rise/Fall Time										
	20% to 80%	115	188	260	130	190	250	145	190	235	ps

All parameters tested ≤ 1 GHz unless otherwise noted.

NOTE 1: Measured from the differential input crossing point to the differential output crossing point.

NOTE 2: Defined as skew between outputs at the same supply voltage and with equal load conditions. Measured at the output differential cross points.

NOTE 3: Defined as skew between outputs on different devices operating at the same supply voltages and with equal load conditions. Using the same type of inputs on each device, the outputs are measured at the differential cross points.

NOTE 4: This parameter is defined in accordance with JEDEC Standard 65.

PARAMETER MEASUREMENT INFORMATION

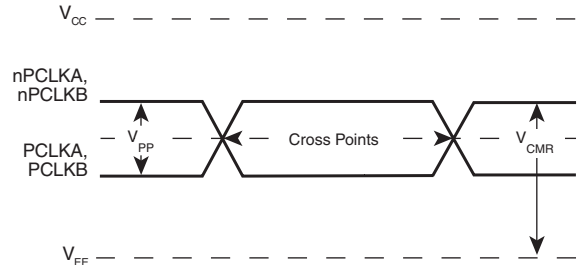
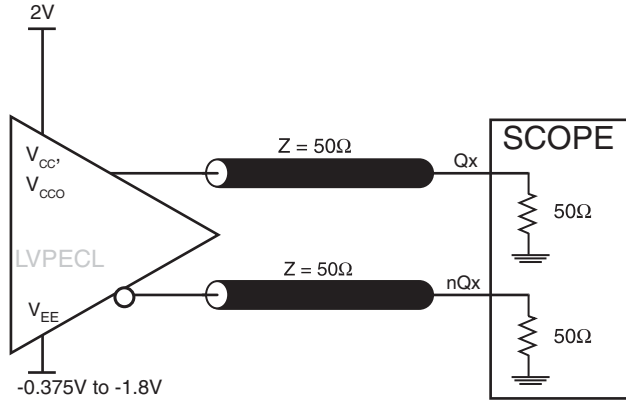

OUTPUT LOAD AC TEST CIRCUIT

DIFFERENTIAL INPUT LEVEL

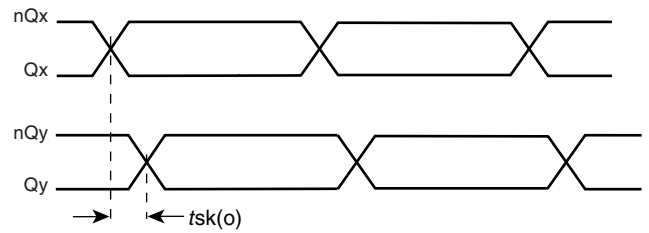
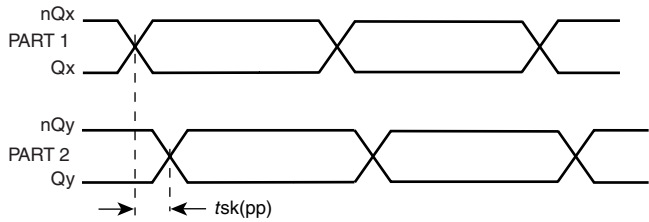

PART-TO-PART SKEW

OUTPUT SKEW

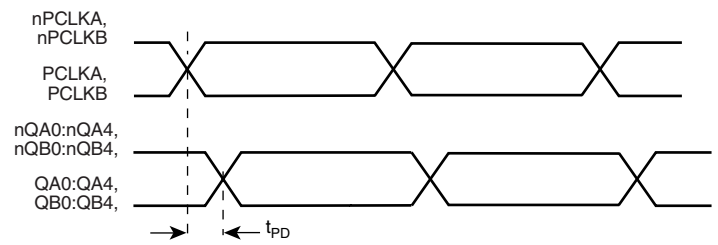
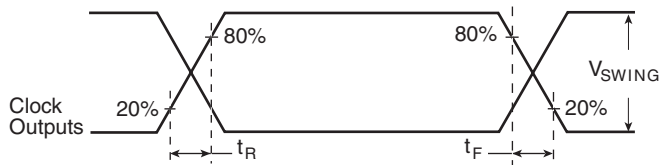

OUTPUT RISE/FALL TIME

PROPAGATION DELAY

APPLICATION INFORMATION

WIRING THE DIFFERENTIAL INPUT TO ACCEPT SINGLE ENDED LVPECL LEVELS

Figure 1A shows an example of the differential input that can be wired to accept single ended levels. The reference voltage level V_{BB} generated from the device is connected to the negative

input. The C1 capacitor should be located as close as possible to the input pin.

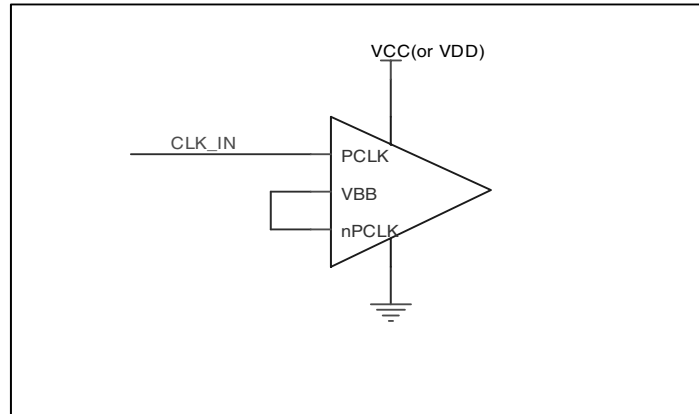

FIGURE 1A. SINGLE ENDED LVPECL SIGNAL DRIVING DIFFERENTIAL INPUT

WIRING THE DIFFERENTIAL INPUT TO ACCEPT SINGLE ENDED LEVELS

Figure 1B shows how the differential input can be wired to accept single ended levels. The reference voltage $V_{REF} \approx V_{CC}/2$ is generated by the bias resistors R1, R2 and C1. This bias circuit should be located as close as possible to the input pin. The ratio

of R1 and R2 might need to be adjusted to position the V_{REF} in the center of the input voltage swing. For example, if the input clock swing is only 2.5V and $V_{CC} = 3.3V$, V_{REF} should be 1.25V and $R2/R1 = 0.609$.

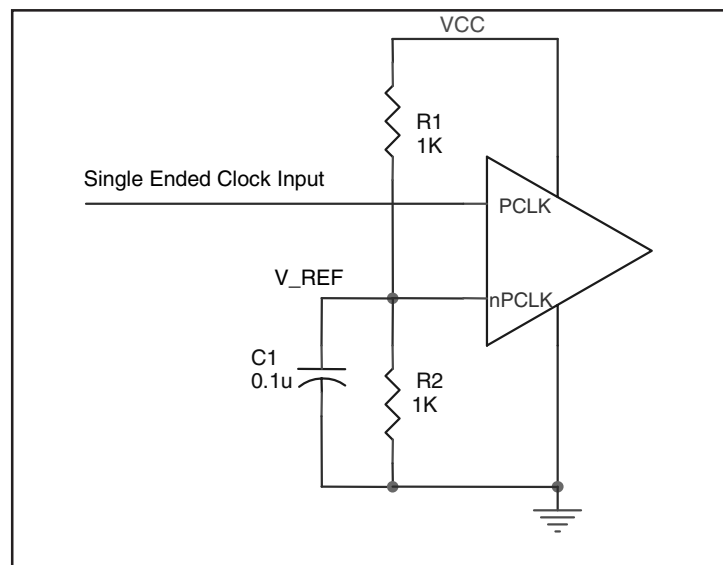

FIGURE 1B. SINGLE ENDED SIGNAL DRIVING DIFFERENTIAL INPUT

LVPECL CLOCK INPUT INTERFACE

The PCLK /nPCLK accepts LVPECL, CML, SSTL and other differential signals. Both V_{SWING} and V_{OH} must meet the V_{PP} and V_{CMR} input requirements. Figures 2A to 2E show interface examples for the HiPerClockS PCLK/nPCLK input driven by the most common driver types. The input interfaces suggested

here are examples only. If the driver is from another vendor, use their termination recommendation. Please consult with the vendor of the driver component to confirm the driver termination requirements.

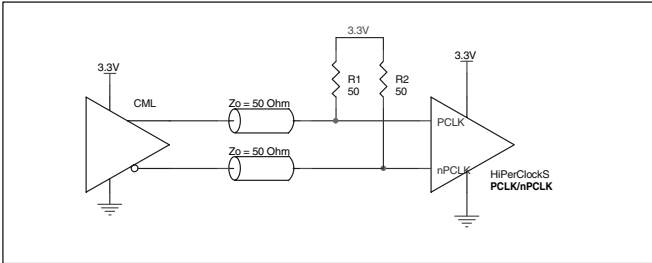

FIGURE 2A. HiPerClockS PCLK/nPCLK INPUT DRIVEN BY A CML DRIVER

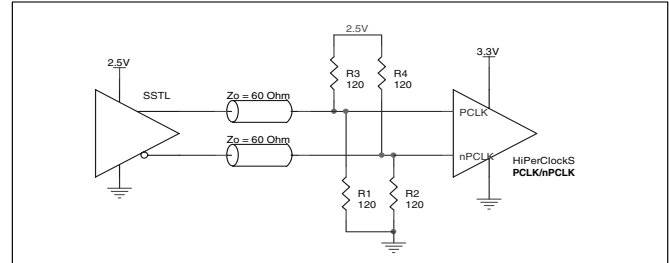

FIGURE 2B. HiPerClockS PCLK/nPCLK INPUT DRIVEN BY AN SSTL DRIVER

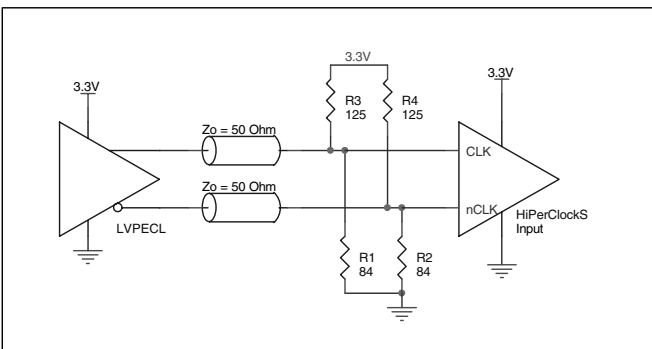

FIGURE 2C. HiPerClockS PCLK/nPCLK INPUT DRIVEN BY A 3.3V LVPECL DRIVER

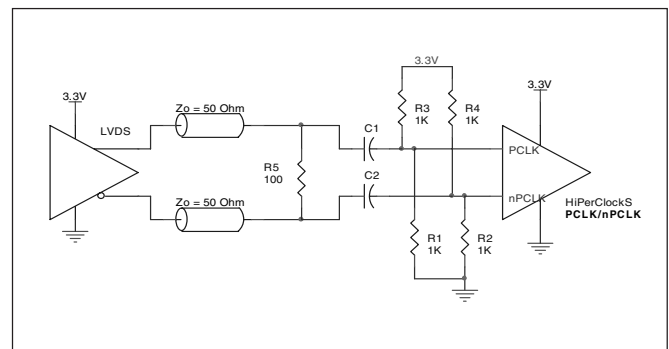

FIGURE 2D. HiPerClockS PCLK/nPCLK INPUT DRIVEN BY A 3.3V LVDS DRIVER

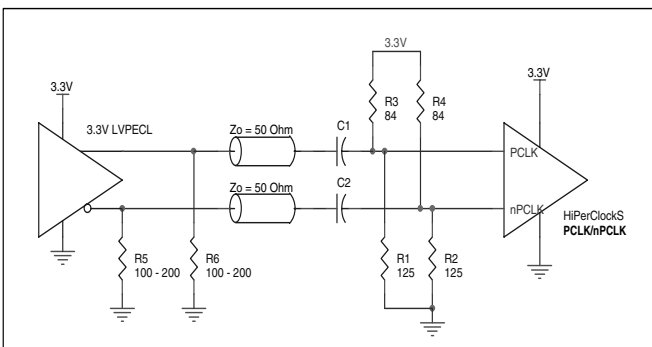

FIGURE 2E. HiPerClockS PCLK/nPCLK INPUT DRIVEN BY A 3.3V LVPECL DRIVER WITH AC COUPLE

RECOMMENDATIONS FOR UNUSED INPUT AND OUTPUT PINS

INPUTS:

PCLK/nPCLK INPUT:

For applications not requiring the use of a differential input, both the PCLK and nPCLK pins can be left floating. Though not required, but for additional protection, a 1k Ω resistor can be tied from PCLK to ground.

OUTPUTS:

LVPECL OUTPUT

All unused LVPECL outputs can be left floating. We recommend that there is no trace attached. Both sides of the differential output pair should either be left floating or terminated.

TERMINATION FOR 3.3V LVPECL OUTPUTS

The clock layout topology shown below is a typical termination for LVPECL outputs. The two different layouts mentioned are recommended only as guidelines.

FOUT and nFOUT are low impedance follower outputs that generate ECL/LVPECL compatible outputs. Therefore, terminating resistors (DC current path to ground) or current sources must be used for functionality. These outputs are designed to drive 50 Ω

transmission lines. Matched impedance techniques should be used to maximize operating frequency and minimize signal distortion. *Figures 3A and 3B* show two different layouts which are recommended only as guidelines. Other suitable clock layouts may exist and it would be recommended that the board designers simulate to guarantee compatibility across all printed circuit and clock component process variations.

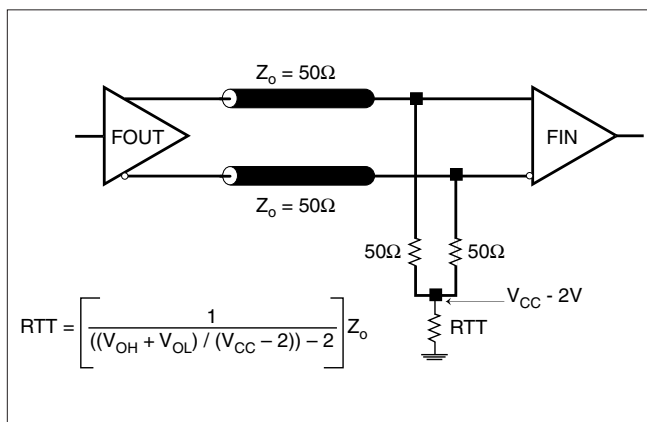

FIGURE 3A. LVPECL OUTPUT TERMINATION

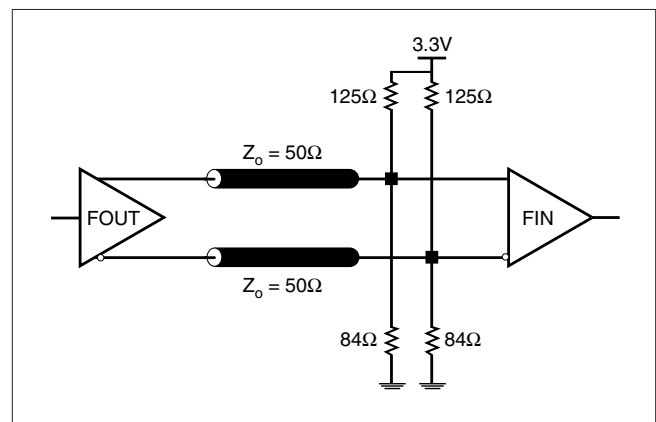

FIGURE 3B. LVPECL OUTPUT TERMINATION

TERMINATION FOR 2.5V LVPECL OUTPUT

Figure 4A and Figure 4B show examples of termination for 2.5V LVPECL driver. These terminations are equivalent to terminating 50Ω to $V_{cc} - 2V$. For $V_{cc} = 2.5V$, the $V_{cc} - 2V$ is very close to ground

level. The R3 in Figure 4B can be eliminated and the termination is shown in Figure 4C.

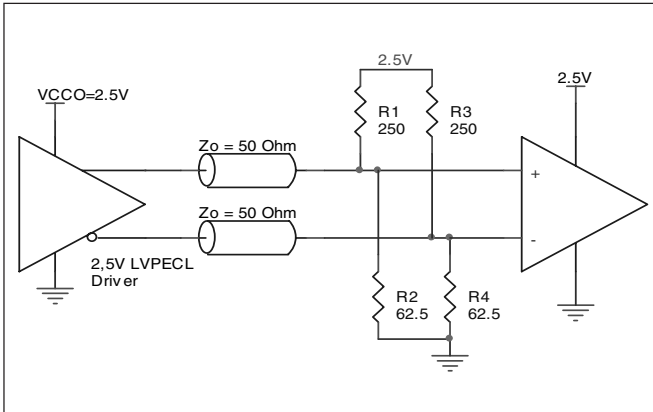

FIGURE 4A. 2.5V LVPECL DRIVER TERMINATION EXAMPLE

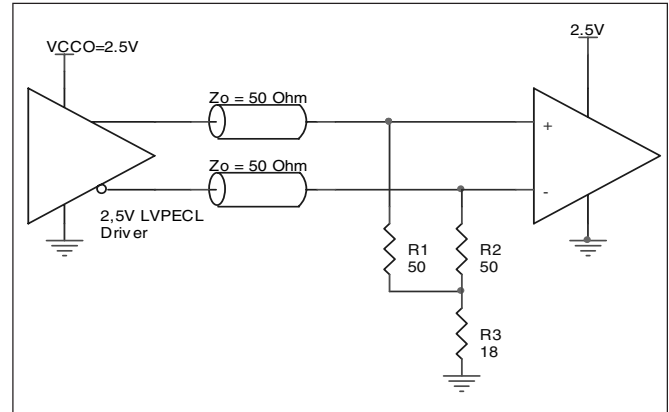

FIGURE 4B. 2.5V LVPECL DRIVER TERMINATION EXAMPLE

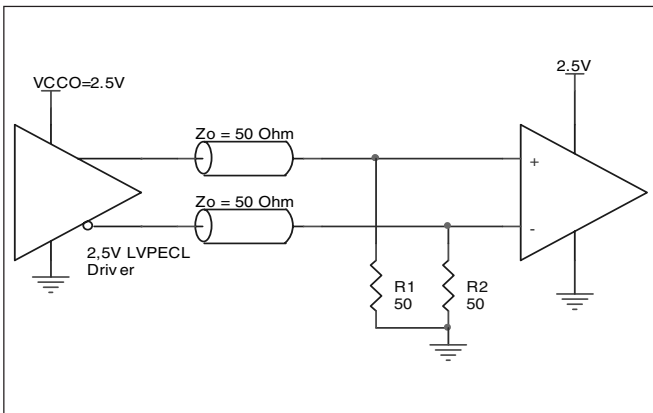

FIGURE 4C. 2.5V LVPECL TERMINATION EXAMPLE

POWER CONSIDERATIONS

This section provides information on power dissipation and junction temperature for the ICS853210. Equations and example calculations are also provided.

1. Power Dissipation.

The total power dissipation for the ICS853210 is the sum of the core power plus the power dissipated in the load(s). The following is the power dissipation for $V_{CC} = 3.8V$, which gives worst case results.

NOTE: Please refer to Section 3 for details on calculating power dissipated in the load.

- Power (core)_{MAX} = $V_{CC,MAX} * I_{EE,MAX} = 3.8V * 80mA = 304mW$
- Power (outputs)_{MAX} = **30.94mW/Loaded Output pair**
If all outputs are loaded, the total power is $10 * 30.94mW = 309.4mW$

$$\text{Total Power}_{MAX} (3.465V, \text{ with all outputs switching}) = 304mW + 309.4mW = 613.4mW$$

2. Junction Temperature.

Junction temperature, T_j , is the temperature at the junction of the bond wire and bond pad and directly affects the reliability of the device. The maximum recommended junction temperature for HiPerClockS™ devices is 125°C.

The equation for T_j is as follows: $T_j = \theta_{JA} * Pd_{total} + T_A$

T_j = Junction Temperature

θ_{JA} = junction-to-Ambient Thermal Resistance

Pd_{total} = Total Device Power Dissipation (example calculation is in section 1 above)

T_A = Ambient Temperature

In order to calculate junction temperature, the appropriate junction-to-ambient thermal resistance θ_{JA} must be used. Assuming a moderate air flow of 200 linear feet per minute and a multi-layer board, the appropriate value is 42.1°C/W per Table 6 below.

Therefore, T_j for an ambient temperature of 85°C with all outputs switching is:

$$85^\circ C + 0.613W * 42.1^\circ C/W = 110.8^\circ C. \text{ This is well below the limit of } 125^\circ C.$$

This calculation is only an example. T_j will obviously vary depending on the number of loaded outputs, supply voltage, air flow, and the type of board (single layer or multi-layer).

TABLE 6. THERMAL RESISTANCE θ_{JA} FOR 32-PIN LQFP FORCED CONVECTION

θ_{JA} by Velocity (Linear Feet per Minute)			
	0	200	500
Single-Layer PCB, JEDEC Standard Test Boards	67.8°C/W	55.9°C/W	50.1°C/W
Multi-Layer PCB, JEDEC Standard Test Boards	47.9°C/W	42.1°C/W	39.4°C/W

NOTE: Most modern PCB designs use multi-layered boards. The data in the second row pertains to most designs.

3. Calculations and Equations.

The purpose of this section is to derive the power dissipated into the load.

LVPECL output driver circuit and termination are shown in *Figure 5*.

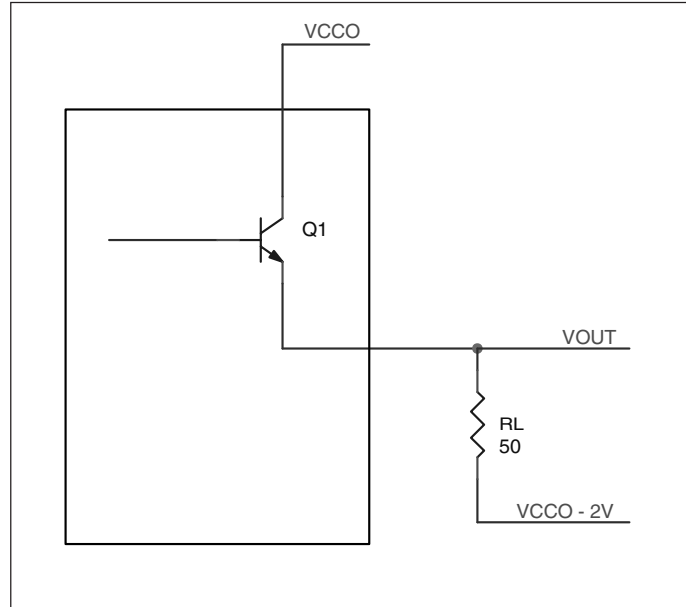

FIGURE 5. LVPECL DRIVER CIRCUIT AND TERMINATION

To calculate worst case power dissipation into the load, use the following equations which assume a 50Ω load, and a termination voltage of $V_{CCO} - 2V$.

- For logic high, $V_{OUT} = V_{OH_MAX} = V_{CCO_MAX} - 0.935V$

$$(V_{CCO_MAX} - V_{OH_MAX}) = 0.935V$$

- For logic low, $V_{OUT} = V_{OL_MAX} = V_{CCO_MAX} - 1.67V$

$$(V_{CCO_MAX} - V_{OL_MAX}) = 1.67V$$

Pd_H is power dissipation when the output drives high.

Pd_L is the power dissipation when the output drives low.

$$Pd_H = [(V_{OH_MAX} - (V_{CCO_MAX} - 2V))/R_L] * (V_{CCO_MAX} - V_{OH_MAX}) = [(2V - (V_{CCO_MAX} - V_{OH_MAX}))/R_L] * (V_{CCO_MAX} - V_{OH_MAX}) = [(2V - 0.935V)/50\Omega] * 0.935V = 19.92mW$$

$$Pd_L = [(V_{OL_MAX} - (V_{CCO_MAX} - 2V))/R_L] * (V_{CCO_MAX} - V_{OL_MAX}) = [(2V - (V_{CCO_MAX} - V_{OL_MAX}))/R_L] * (V_{CCO_MAX} - V_{OL_MAX}) = [(2V - 1.67V)/50\Omega] * 1.67V = 11.2mW$$

Total Power Dissipation per output pair = $Pd_H + Pd_L = 30.94mW$

RELIABILITY INFORMATION

TABLE 7. θ_{JA} VS. AIR FLOW TABLE FOR 32 LEAD LQFP

	θ_{JA} by Velocity (Linear Feet per Minute)		
	0	200	500
Single-Layer PCB, JEDEC Standard Test Boards	67.8°C/W	55.9°C/W	50.1°C/W
Multi-Layer PCB, JEDEC Standard Test Boards	47.9°C/W	42.1°C/W	39.4°C/W

NOTE: Most modern PCB designs use multi-layered boards. The data in the second row pertains to most designs.

TRANSISTOR COUNT

The transistor count for ICS853210 is: 437

Pin compatible with MC100EP210 and MC100LVEP210

PACKAGE OUTLINE AND DIMENSIONS - Y SUFFIX FOR 32 LEAD LQFP

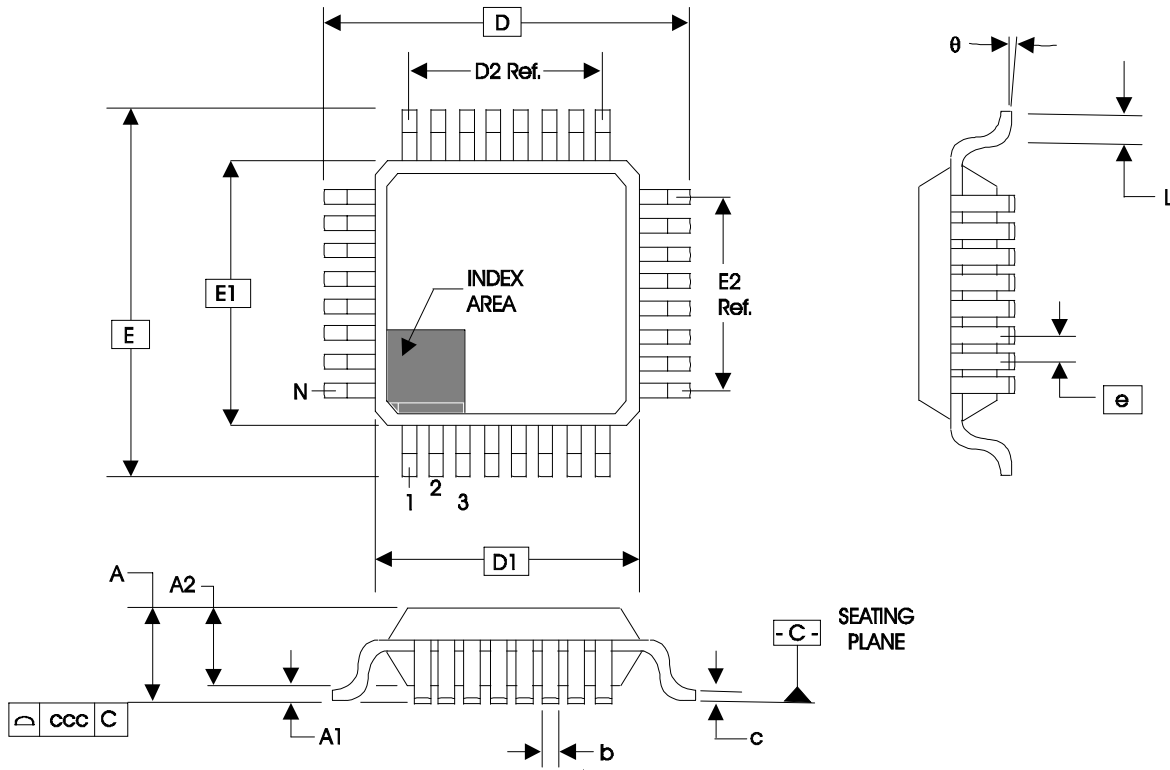

TABLE 8. PACKAGE DIMENSIONS

JEDEC VARIATION ALL DIMENSIONS IN MILLIMETERS			
SYMBOL	BBA		
	MINIMUM	NOMINAL	MAXIMUM
N	32		
A	--	--	1.60
A1	0.05	--	0.15
A2	1.35	1.40	1.45
b	0.30	0.37	0.45
c	0.09	--	0.20
D	9.00 BASIC		
D1	7.00 BASIC		
D2	5.60 Ref.		
E	9.00 BASIC		
E1	7.00 BASIC		
E2	5.60 Ref.		
e	0.80 BASIC		
L	0.45	0.60	0.75
θ	0°	--	7°
ccc	--	--	0.10

Reference Document: JEDEC Publication 95, MS-026

TABLE 9. ORDERING INFORMATION

Part/Order Number	Marking	Package	Shipping Packaging	Temperature
ICS853210AY	ICS853210AY	32 Lead LQFP	tray	-40°C to 85°C
ICS853210AYT	ICS853210AY	32 Lead LQFP	1000 tape & reel	-40°C to 85°C
ICS853210AYLF	ICS853210AYL	32 Lead "Lead-Free" LQFP	tray	-40°C to 85°C
ICS853210AYLFT	ICS853210AYL	32 Lead "Lead-Free" LQFP	1000 tape & reel	-40°C to 85°C

NOTE: Parts that are ordered with an "LF" suffix to the part number are the Pb-Free configuration and are RoHS compliant.

While the information presented herein has been checked for both accuracy and reliability, Integrated Device Technology, Incorporated (IDT) assumes no responsibility for either its use or for infringement of any patents or other rights of third parties, which would result from its use. No other circuits, patents, or licenses are implied. This product is intended for use in normal commercial and industrial applications. Any other applications such as those requiring high reliability or other extraordinary environmental requirements are not recommended without additional processing by IDT. IDT reserves the right to change any circuitry or specifications without notice. IDT does not authorize or warrant any IDT product for use in life support devices or critical medical instruments.

REVISION HISTORY SHEET

Rev	Table	Page	Description of Change	Date
A	T8	1	Features Section - added lead-free bullet.	10/23/06
		9	Added <i>Recommendations for Unused Input and Output Pins</i> .	
		15	Ordering Information Table - added lead-free part number, marking, and note.	

ICS853210

LOW SKEW, DUAL, 1-TO-5, DIFFERENTIAL-TO-2.5, 3.3V LVPECL/ECL FANOUT BUFFER

Innovate with IDT and accelerate your future networks. Contact:

www.IDT.com

For Sales

800-345-7015
408-284-8200
Fax: 408-284-2775

For Tech Support

netcom@idt.com
480-763-2056

Corporate Headquarters

Integrated Device Technology, Inc.
6024 Silver Creek Valley Road
San Jose, CA 95138
United States
800 345 7015
+408 284 8200 (outside U.S.)

Asia Pacific and Japan

Integrated Device Technology
Singapore (1997) Pte. Ltd.
Reg. No. 199707558G
435 Orchard Road
#20-03 Wisma Atria
Singapore 238877
+65 6 887 5505

Europe

IDT Europe, Limited
321 Kingston Road
Leatherhead, Surrey
KT22 7TU
England
+44 (0) 1372 363 339
Fax: +44 (0) 1372 378851



www.IDT.com

© 2006 Integrated Device Technology, Inc. All rights reserved. Product specifications subject to change without notice. IDT, the IDT logo, ICS and HiPerClockS are trademarks of Integrated Device Technology, Inc. Accelerated Thinking is a service mark of Integrated Device Technology, Inc. All other brands, product names and marks are or may be trademarks or registered trademarks used to identify products or services of their respective owners.
Printed in USA

Looking for pricing, stock, or lifecycle information?

Click below to explore more details on WIN SOURCE:

- [View ICS853210AYLF on WIN SOURCE](#)
- [IDT, Integrated Device Technology Inc Information](#)

Optimize Your Supply Chain with WIN SOURCE Solutions

- ✓ Global Sourcing Solution
- ✓ Obsolete Management
- ✓ Cost Control Management
- ✓ Shortage Management
- ✓ Alternative Solution
- ✓ Excess Inventory Management