



**THE DATASHEET OF
MAX6968AAE+**





8-Port, 5.5V Constant-Current LED Driver

MAX6968

General Description

The MAX6968 serial-interfaced LED driver provides eight open-drain, constant-current sinking LED driver outputs rated at 5.5V. The MAX6968 operates from a 3V to 5.5V supply. The MAX6968 supply and the LEDs' supply or supplies may power up in any order. The constant-current outputs are programmed together to up to 55mA using a single external resistor. The MAX6968 operates with a 25Mb, industry-standard, 4-wire serial interface.

The MAX6968 uses the industry-standard shift-register-plus-latch-type serial interface. The driver accepts data shifted into an 8-bit shift register using data input DIN and clock input CLK. Input data appears at the output DOUT eight clock cycles later to allow cascading of multiple MAX6968s. The latch-enable input LE loads the 8 bits of shift register data into an 8-bit output latch to set which LEDs are on and which are off. The output-enable input \overline{OE} gates all eight outputs on and off, and is fast enough to be used as a PWM input for LED intensity control.

For applications requiring LED fault detection, refer to the MAX6977 data sheet that automatically detects open-circuit LEDs.

For safety-related applications requiring a watchdog timer, refer to the MAX6978 data sheet that includes a fail-safe feature that blanks the display if the serial interface becomes inactive for more than 1s.

The MAX6968 is one of a family of 12 shift-register-plus-latch-type LED drivers. The family includes 8-port and 16-port types, with 5.5V- or 36V-rated LED outputs, with and without open-circuit LED detection and watchdog. All versions operate from a 3V to 5.5V supply, and are specified over the -40°C to +125°C temperature range.

Applications

- Variable Message Signs
- Marquee Displays
- Point-of-Order Signs
- Traffic Signs
- Gaming Features
- Architectural Lighting

Features

- ◆ 25Mb Industry-Standard 4-Wire Serial Interface at 5V
- ◆ 3V to 5.5V Logic Supply
- ◆ 8 Constant-Current LED Outputs Rated at 5.5V
- ◆ Up to 55mA Continuous Current per Output
- ◆ Output Current Programmed by Single Resistor
- ◆ 3% Current Matching Between Outputs
- ◆ 6% Current Matching Between ICs
- ◆ -40°C to +125°C Temperature Range

Ordering Information

PART	TEMP RANGE	PIN-PACKAGE
MAX6968AUE	-40°C to +125°C	16 TSSOP-EP*
MAX6968APE	-40°C to +125°C	16 PDIP
MAX6968AAE	-40°C to +125°C	16 SSOP

*EP = Exposed pad.

Typical Application Circuit and Selector Guide appear at end of data sheet.

Pin Configuration

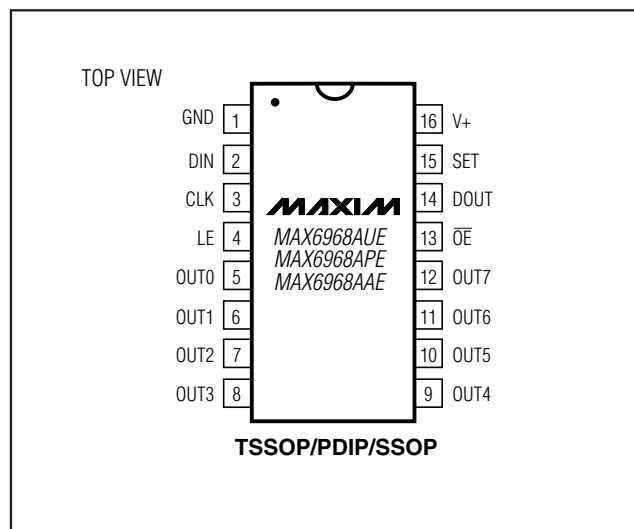

8-Port, 5.5V Constant-Current LED Driver

ABSOLUTE MAXIMUM RATINGS

Voltage (with respect to GND)

V+	-0.3V to +6V
OUT ₋	-0.3V to +6V
DIN, CLK, LE, \overline{OE} , SET	-0.3V to (V+ + 0.3V)
DOUT Current	±10mA
OUT ₋ Sink Current	60mA
Total GND Current	480mA

Continuous Power Dissipation (T_A = +70°C)

16-Pin SSOP (derate 7.1mW/°C above +70°C)	571mW
16-Pin PDIP (derate 10.5mW/°C above +70°C)	842mW
16-Pin TSSOP (derate 21.3mW/°C over T _A = +70°C)	1702mW
Operating Temperature Range	-40°C to +125°C
Junction Temperature	+150°C
Storage Temperature Range	-65°C to +150°C
Lead Temperature (soldering, 10s)	+300°C

Stresses beyond those listed under "Absolute Maximum Ratings" may cause permanent damage to the device. These are stress ratings only, and functional operation of the device at these or any other conditions beyond those indicated in the operational sections of the specifications is not implied. Exposure to absolute maximum rating conditions for extended periods may affect device reliability.

ELECTRICAL CHARACTERISTICS

(Typical Operating Circuit, V+ = 3V to 5.5V, T_A = T_{MIN} to T_{MAX}, unless otherwise noted. Typical values are at V+ = 5V, T_A = +25°C.) (Note 1)

PARAMETER	SYMBOL	CONDITIONS	MIN	TYP	MAX	UNITS
Operating Supply Voltage	V+		3.0		5.5	V
Output Voltage	V _{OUT}				5.5	V
Standby Current (Interface Idle, All Output Ports High Impedance, R _{SET} = 360Ω)	I ₊	All logic inputs at V+ or GND, DOUT unloaded		4.5	5.6	mA
Standby Current (Interface Running, All Output Ports High Impedance, R _{SET} = 360Ω)	I ₊	f _{CLK} = 5MHz, \overline{OE} = V+, DIN and LE = V+ or GND, DOUT unloaded		4.7	6	mA
Supply Current (Interface Idle, All Output Ports Active Low, R _{SET} = 360Ω)	I ₊	All logic inputs at V+ or GND, DOUT unloaded		10	25	mA
Input High Voltage DIN, CLK, LE, \overline{OE}	V _{IH}		0.7 V+			V
Input Low Voltage DIN, CLK, LE, \overline{OE}	V _{IL}				0.3 V+	V
Hysteresis Voltage DIN, CLK, LE, \overline{OE}	ΔV _I			0.8		V
Input Leakage Current DIN, CLK, LE, \overline{OE}	I _{IH} , I _{IL}		-1		+1	μA
Output High-Voltage DOUT	V _{OH}	I _{SOURCE} = 4mA	V+		-0.5V	V
Output Low Voltage	V _{OL}	I _{SINK} = 4mA			0.5	V
Output Current OUT ₋	I _{OUT}	V+ = 3V to 5.5V, V _{OUT} = 0.5V to 2.5V, R _{SET} = 360Ω	42	50	56	mA
Output Leakage Current OUT ₋	I _{LEAK}	\overline{OE} = V+, V _{OUT} = V+			1	μA
Watchdog Timeout	t _{WD}			1		s

8-Port, 5.5V Constant-Current LED Driver

MAX6968

5V TIMING CHARACTERISTICS

(Typical Operating Circuit, V+ = 4.5V to 5.5V, T_A = T_{MIN} to T_{MAX}, unless otherwise noted.) (Note 1)

PARAMETER	SYMBOL	CONDITIONS	MIN	TYP	MAX	UNITS
CLK Clock Period	t _{CP}		40			ns
CLK Pulse-Width High	t _{CH}		19			ns
CLK Pulse-Width Low	t _{CL}		19			ns
DIN Setup Time	t _{DS}		4			ns
DIN Hold Time	t _{DH}		8			ns
DOUT Propagation Delay	t _{DO}		12		32	ns
DOUT Rise and Fall Time	t _{DR} , t _{DF}	C _{DOUT} = 10pF, 20% to 80%			10	ns
LE Pulse-Width High	t _{LW}		20			ns
LE Setup Time	t _{LS}		10			ns
LE Rising to OUT_ Rising Delay	t _{LRR}	(Note 2)			100	ns
LE Rising to OUT_ Falling Delay	t _{LRF}	(Note 2)			280	ns
CLK Rising to OUT_ Rising Delay	t _{CRR}	(Note 2)			100	ns
CLK Rising to OUT_ Falling Delay	t _{CRF}	(Note 2)			310	ns
\overline{OE} Rising to OUT_ Rising Delay	t _{OEH}				100	ns
\overline{OE} Falling to OUT_ Falling Delay	t _{OEL}				300	ns
LED Output OUT_ Turn-On Fall Time	t _f	80% to 20%			200	ns
LED Output OUT_ Turn-Off Rise Time	t _r	20% to 80%			120	ns

8-Port, 5.5V Constant-Current LED Driver

3.3V TIMING CHARACTERISTICS

(Typical Operating Circuit, $V_+ = 3V$ to $5.5V$, $T_A = T_{MIN}$ to T_{MAX} , unless otherwise noted.) (Note 1)

PARAMETER	SYMBOL	CONDITIONS	MIN	TYP	MAX	UNITS
CLK Clock Period	t_{CP}		52			ns
CLK Pulse-Width High	t_{CH}		24			ns
CLK Pulse-Width Low	t_{CL}		24			ns
DIN Setup Time	t_{DS}		4			ns
DIN Hold Time	t_{DH}		8			ns
DOUT Propagation Delay	t_{DO}		12		48	ns
DOUT Rise and Fall Time	t_{DR}, t_{DF}	$C_{DOUT} = 10pF, 20\%$ to 80%			10	ns
LE Pulse-Width High	t_{LW}		20			ns
LE Setup Time	t_{LS}		15			ns
LE Rising to OUT_ Rising Delay	t_{LRR}				100	ns
LE Rising to OUT_ Falling Delay	t_{LRF}				310	ns
CLK Rising to OUT_ Rising Delay	t_{CRR}				100	ns
CLK Rising to OUT_ Falling Delay	t_{CRF}				330	ns
\overline{OE} Rising to OUT_ Rising Delay	$t_{\overline{OE}H}$				100	ns
\overline{OE} Falling to OUT_ Falling Delay	$t_{\overline{OE}L}$				330	ns
LED Output OUT_ Turn-On Fall Time	t_f	80% to 20%			200	ns
LED Output OUT_ Turn-Off Rise Time	t_r	20% to 80%			120	ns

Note 1: All parameters tested at $T_A = +25^\circ C$. Specifications over temperature are guaranteed by design.

Note 2: See Figure 3.

Typical Operating Characteristics

($T_A = +25^\circ C$, unless otherwise noted.)

**SUPPLY CURRENT vs. SUPPLY VOLTAGE
(INTERFACE IDLE, ALL OUTPUTS OFF,
 $R_{SET} = 720\Omega$)**

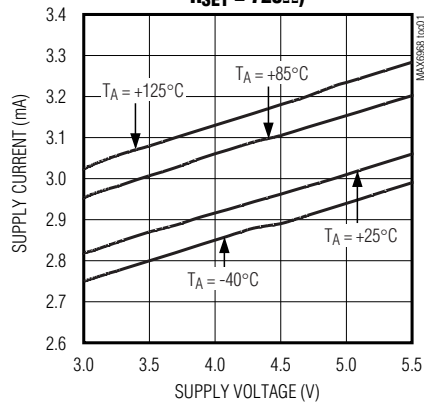

**SUPPLY CURRENT vs. SUPPLY VOLTAGE
(INTERFACE IDLE, ALL OUTPUTS
OFF, $R_{SET} = 360\Omega$)**

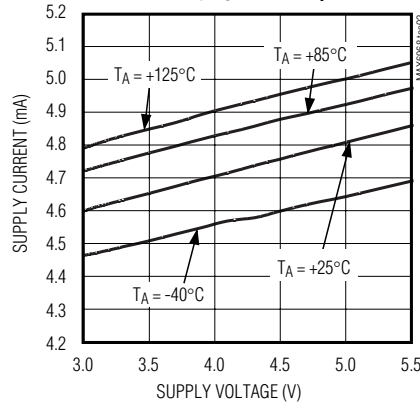

**SUPPLY CURRENT vs. SUPPLY VOLTAGE
(INTERFACE IDLE, ALL OUTPUTS
ON, $R_{SET} = 720\Omega$)**

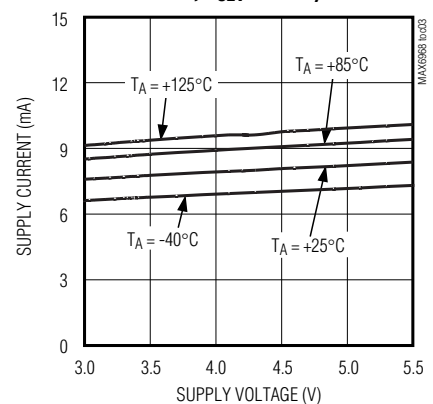

8-Port, 5.5V Constant-Current LED Driver

Typical Operating Characteristics (continued)

($T_A = +25^\circ\text{C}$, unless otherwise noted.)

MAX6968

SUPPLY CURRENT vs. SUPPLY VOLTAGE
(INTERFACE IDLE, ALL OUTPUTS ON, $R_{SET} = 360\Omega$)

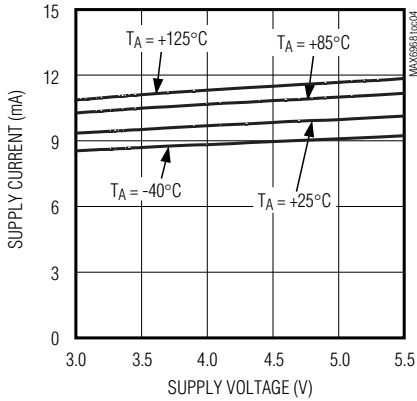

PORT OUTPUT CURRENT vs. PORT OUTPUT VOLTAGE
($R_{SET} = 720\Omega$, $V_+ = 3.3\text{V}$)

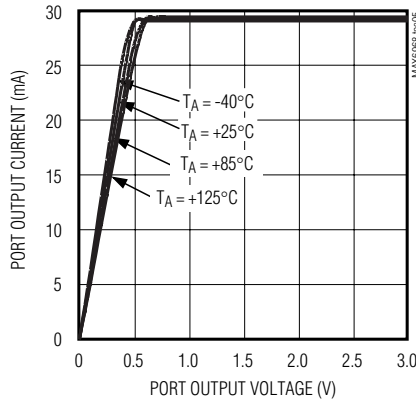

PORT OUTPUT CURRENT vs. PORT OUTPUT VOLTAGE
($R_{SET} = 360\Omega$, $V_+ = 3.3\text{V}$)

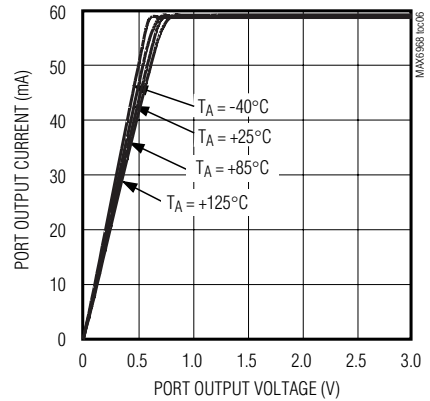

PORT OUTPUT CURRENT vs. PORT OUTPUT VOLTAGE
($R_{SET} = 720\Omega$, $V_+ = 5.0\text{V}$)

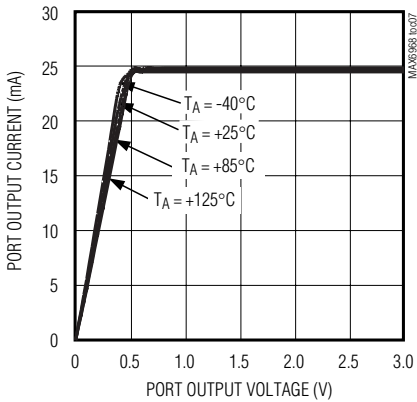

PORT OUTPUT CURRENT vs. PORT OUTPUT VOLTAGE
($R_{SET} = 360\Omega$, $V_+ = 5.0\text{V}$)

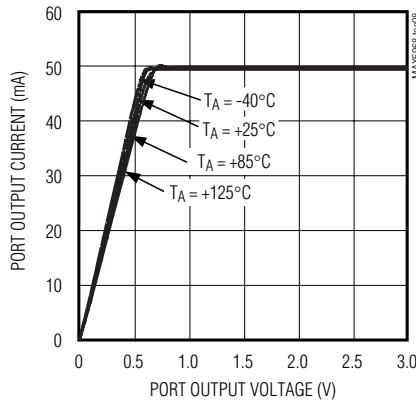

PORT OUTPUT CURRENT vs. SUPPLY VOLTAGE
($R_{SET} = 720\Omega$, $V_{OUT} = 2\text{V}$)

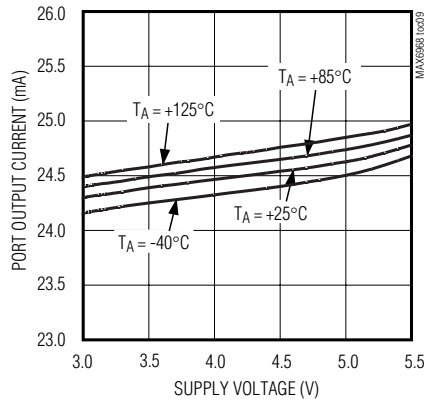

PORT OUTPUT CURRENT vs. SUPPLY VOLTAGE
($R_{SET} = 360\Omega$, $V_{OUT} = 2\text{V}$)

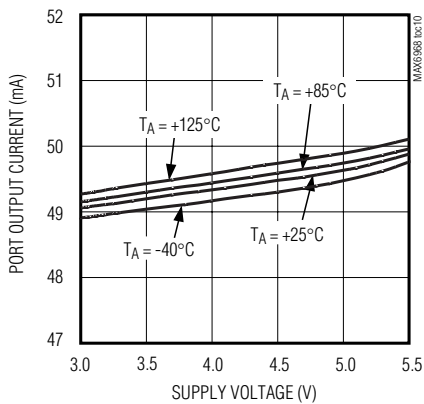

PORT OUTPUT CURRENT vs. R_{SET} RESISTANCE
($V_+ = 5.0\text{V}$)

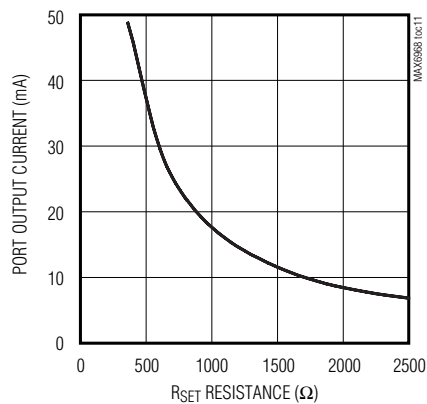

8-Port, 5.5V Constant-Current LED Driver

Pin Description

PIN	NAME	FUNCTION
1	GND	Ground
2	DIN	Serial-Data Input. Data is loaded into the internal 8-bit shift register on CLK's rising edge.
3	CLK	Serial-Clock Input. Data is loaded into the internal 8-bit shift register on CLK's rising edge.
4	LE	Load-Enable Input. Data is loaded transparently from the internal shift register to the output latch while LE is high. Data is latched into the output latch on LE's falling edge, and retained while LE is low.
5–12	OUT0–OUT7	LED Driver Outputs. OUT0–OUT7 are open-drain, constant-current sinking outputs rated to 5.5V.
13	\overline{OE}	Output-Enable Input. High forces outputs OUT0–OUT7 to high impedance, without altering the contents of the output latches. Low enables outputs OUT0–OUT7 to follow the state of the output latches.
14	DOUT	Serial-Data Output. Data is clocked out of the 8-bit internal shift register to DOUT on CLK's rising edge.
15	SET	LED Current Setting. Connect SET to GND through a resistor (R_{SET}) to set the maximum LED current.
16	V+	Positive Supply Voltage. Bypass V+ to GND with a 0.1 μ F ceramic capacitor.
PAD	Exposed pad*	Exposed pad on package underside. Connect to GND.

*TSSOP package only.

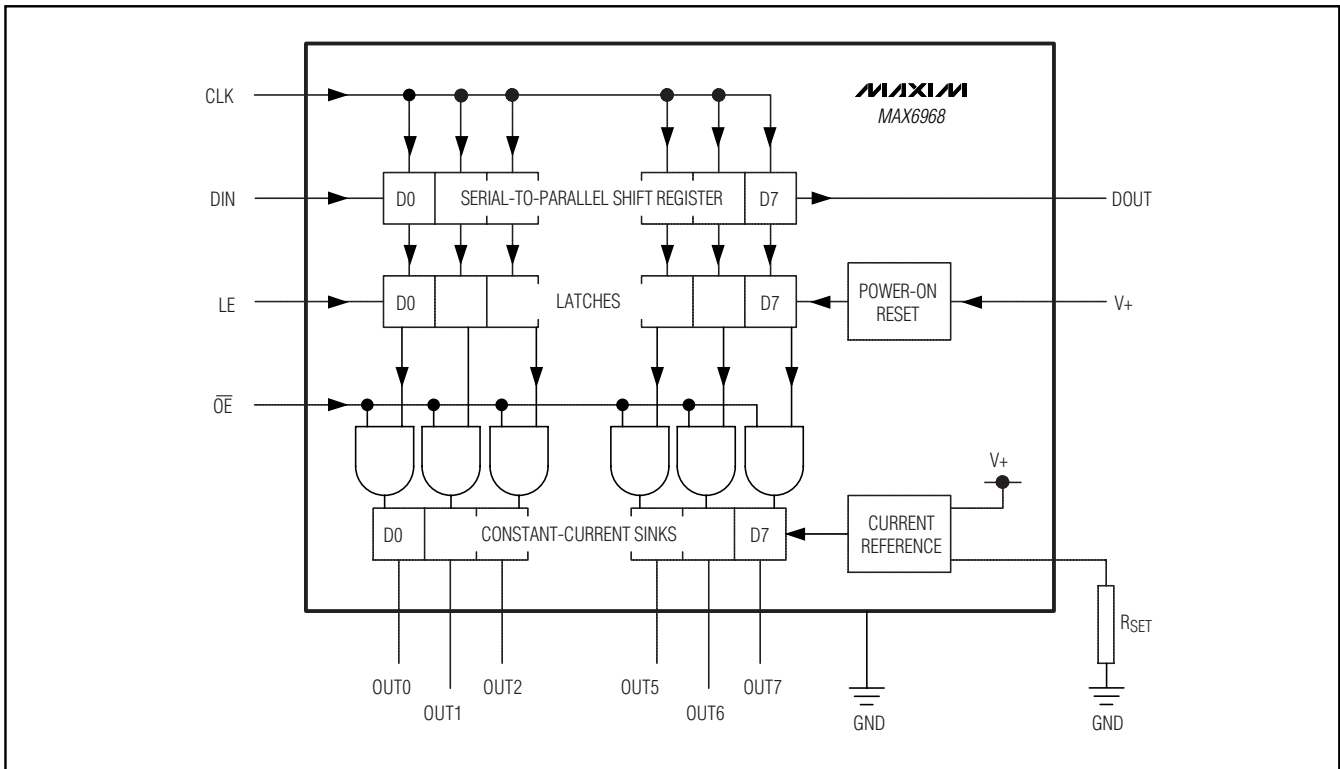

Figure 1. MAX6968 Block Diagram

8-Port, 5.5V Constant-Current LED Driver

Detailed Description

The MAX6968 LED driver comprises a 4-wire serial interface driving eight constant-current sinking open-drain output ports. The outputs drive LEDs in either static or multiplex applications (Figure 1). The constant-current outputs are guaranteed for current accuracy not only with chip-supply voltage variations (5V \pm 10% and 3V to 5.5V), but also over a realistic range of driver output voltage drop (0.5V to 2.5V). The drivers use current-sensing feedback circuitry (not simple current mirrors) to ensure very small current variations over the full allowed range of output voltage (see the *Typical Operating Characteristics*).

The 4-wire serial interface comprises an 8-bit shift register and an 8-bit transparent latch. The shift register is written through a clock input CLK and a data input DIN and the data propagates to a data output DOUT. The data output allows multiple drivers to be cascaded and operated together. The contents of the 8-bit shift register are loaded into the transparent latch through a latch enable input LE. The latch is transparent to the shift register outputs when high, and latches the current state on the falling edge of LE.

Each driver output is an open-drain constant-current sink that should be connected to the cathode of either a single LED or a series string of multiple LEDs. The LED anode can be connected to a supply voltage of up to 5.5V, independent of the MAX6968 supply, $V+$. The constant-current capability is up to 55mA per output, set for all eight outputs by an external resistor, R_{SET} .

Initial Power-Up and Operation

An internal reset circuit clears the internal registers of the MAX6968 on power-up. All outputs OUT_0 – OUT_7 , therefore, initialize high impedance, and the interface output DOUT initializes low, regardless of the initial logic levels of the CLK, DIN, \overline{OE} , and LE inputs.

4-Wire Serial Interface

The serial interface on the MAX6968 is a 4-wire serial interface using four inputs (DIN, CLK, LE, \overline{OE}) and a data output (DOUT). This interface is used to write display data to the MAX6968. The serial-interface data word length is 8 bits, D_0 – D_7 . See Figure 2.

The functions of the five interface pins are as follows. DIN is the serial data input, and must be stable when it is sampled on the rising edge of CLK. Data is shifted in, MSB first. This means that data bit D_7 is clocked in first, followed by 7 more data bits finishing with the LSB D_0 .

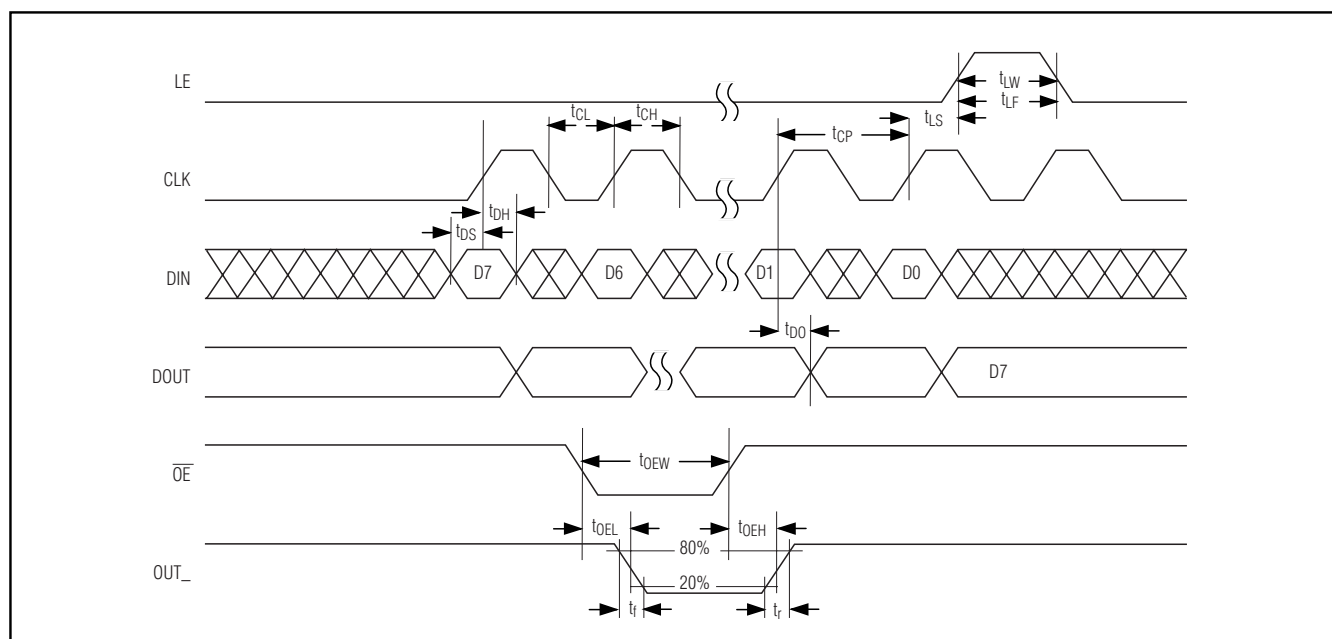

Figure 2. 4-Wire Serial-Interface Timing Diagram

8-Port, 5.5V Constant-Current LED Driver

MAX6968

Applications Information

Selecting External Component R_{SET} to Set LED Output Current

The MAX6968 uses an external resistor R_{SET} to set the LED current for outputs OUT0–OUT7. The minimum allowed value of R_{SET} is 307.6Ω, which sets the output currents to 55mA. The maximum allowed value of R_{SET} is 1.5kΩ. The reference value, 360Ω, sets the output currents to 50mA. To set a different output current, use the formula:

$$R_{SET} = 18,000 / I_{OUT}$$

where I_{OUT} is the desired output current in mA.

Computing Power Dissipation

The upper limit for power dissipation (P_D) for the MAX6968 is determined by the following equation:

$$P_D = (V_+ \times I_+) + (V_{OUT} \times DUTY \times I_{OUT} \times N)$$

where:

V₊ = supply voltage

I₊ = operating supply current when sinking I_{OUT} LED drive current into N outputs

DUTY = PWM duty cycle applied to \overline{OE}

N = number of MAX6968 outputs driving LEDs at the same time (maximum is 8)

V_{OUT} = MAX6968 port output voltage when driving load LED(s)

I_{OUT} = LED drive current programmed by R_{SET}

P_D = power dissipation, in mW if currents are in mA

Dissipation example:

I_{OUT} = 47mA, N = 8, DUTY = 1, V_{OUT} = 2V, V₊ = 5.25V

$$P_D = (5.25V \times 25mA) + (2V \times 1 \times 47mA \times 8) = 0.883W$$

Thus, for a 16-pin TSSOP package (T_{JA} = 1 / 0.0213 = +46.95°C/W from the *Absolute Maximum Ratings*), the maximum allowed ambient temperature T_A is given by:

$$T_{J(MAX)} = T_A + (P_D \times T_{JA}) = +150^\circ C = T_A + (0.883 \times 46.95^\circ C/W)$$

so T_A = +108.5°C.

Overtemperature Cutoff

The MAX6968 contains an internal temperature sensor that turns off all outputs when the die temperature exceeds approximately +165°C. The outputs are enabled again when the die temperature drops below approximately +140°C. Register contents are not affected, so when a driver is overdissipating, the external symptom will be the load LEDs cycling between on and off as the driver repeatedly overheats and cools, alternately turning the LEDs off and then back on again.

Power-Supply Considerations

The MAX6968 operates with a chip supply V₊, and one or more LED supplies. Bypass each supply to GND with a 0.1μF capacitor as close to the MAX6968 as possible. This is normally adequate for static LED driving. For multiplex or PWM applications, it is necessary to add an additional bulk electrolytic capacitor of 4.7μF or more to each supply for every 4 to 16 MAX6968s. The necessary capacitance depends on the LED load current, PWM switching frequency, and serial-interface speed. Inadequate V₊ decoupling can cause timing problems, and very noisy LED supplies can affect LED current regulation.

For the TSSOP version, connect the underside exposed pad to GND.

Chip Information

TRANSISTOR COUNT: 2382

PROCESS: BiCMOS

8-Port, 5.5V Constant-Current LED Driver

Selector Guide

PART	NO. OF OUTPUTS	MAX OUTPUT VOLTAGE (V)	MAX OUTPUT CURRENT	LED FAULT DETECTION	WATCHDOG
MAX6968	8	5.5	55mA	—	—
MAX6977				Yes	—
MAX6978				Yes	Yes
MAX6970	8	36		—	—
MAX6981				Yes	—
MAX6980				Yes	Yes
MAX6969	16	5.5		—	—
MAX6984				Yes	—
MAX6979			Yes	Yes	
MAX6971	16	36	—	—	
MAX6982			Yes	—	
MAX6983			Yes	Yes	

Typical Application Circuit

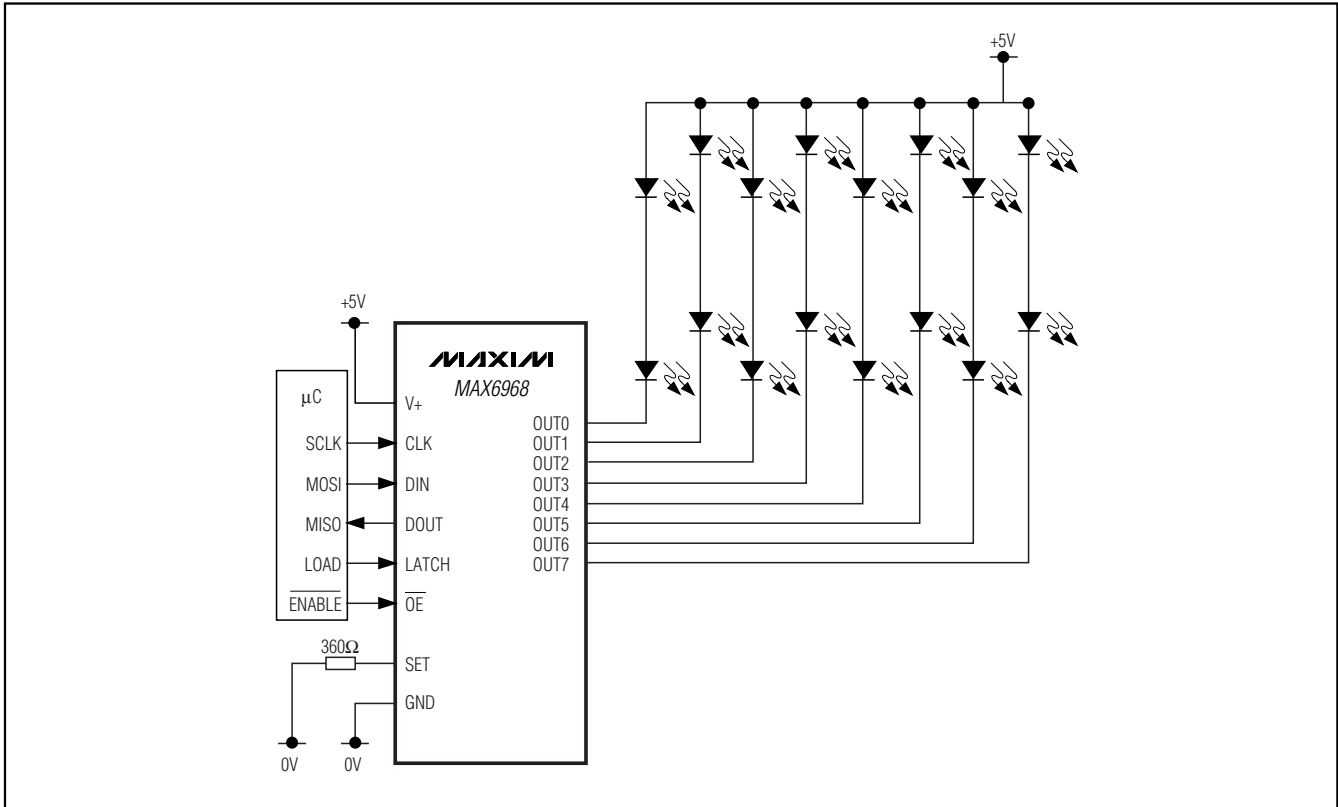

8-Port, 5.5V Constant-Current LED Driver

Package Information

(The package drawing(s) in this data sheet may not reflect the most current specifications. For the latest package outline information, go to www.maxim-ic.com/packages.)

MAX6968

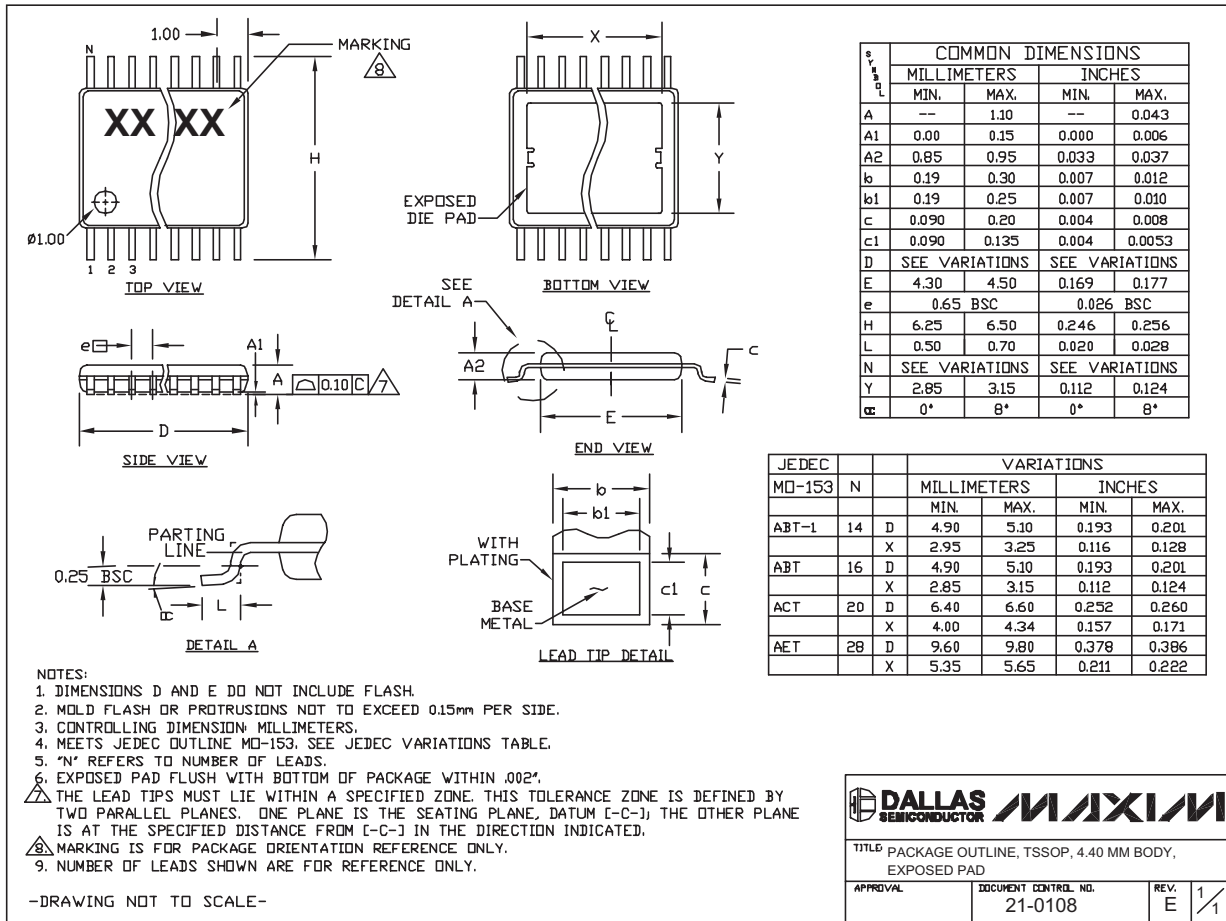

TSSOP 4.4mm BODY, EPS

8-Port, 5.5V Constant-Current LED Driver

Package Information (continued)

(The package drawing(s) in this data sheet may not reflect the most current specifications. For the latest package outline information, go to www.maxim-ic.com/packages.)

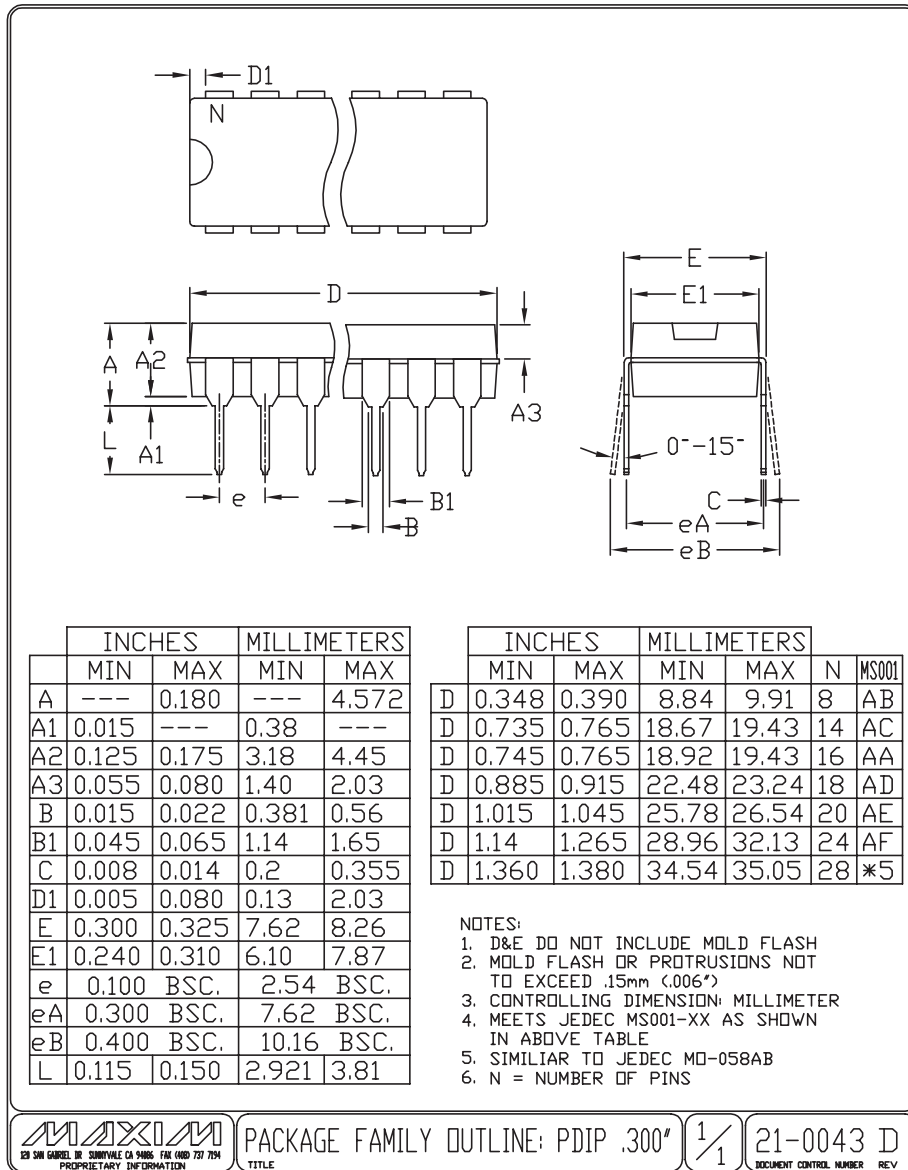

MAXIM
 120 SAN GABRIEL DR. SUNNYVALE CA 94086 FAX (415) 737-7594
 PROPRIETARY INFORMATION

PACKAGE FAMILY OUTLINE: PDIP .300" $\frac{1}{1}$

21-0043 D
 DOCUMENT CONTROL NUMBER REV

8-Port, 5.5V Constant-Current LED Driver

Package Information (continued)

(The package drawing(s) in this data sheet may not reflect the most current specifications. For the latest package outline information, go to www.maxim-ic.com/packages.)

MAX6968

DIM	INCHES		MILLIMETERS	
	MIN	MAX	MIN	MAX
A	0.068	0.078	1.73	1.99
A1	0.002	0.008	0.05	0.21
B	0.010	0.015	0.25	0.38
C	0.004	0.008	0.09	0.20
D	SEE VARIATIONS			
E	0.205	0.212	5.20	5.38
e	0.0256 BSC		0.65 BSC	
H	0.301	0.311	7.65	7.90
L	0.025	0.037	0.63	0.95
α	0	8	0	8

D	INCHES		MILLIMETERS		N
	MIN	MAX	MIN	MAX	
D	0.239	0.249	6.07	6.33	14L
D	0.239	0.249	6.07	6.33	16L
D	0.278	0.289	7.07	7.33	20L
D	0.317	0.328	8.07	8.33	24L
D	0.397	0.407	10.07	10.33	28L

NOTES:

- D&E DO NOT INCLUDE MOLD FLASH.
- MOLD FLASH OR PROTRUSIONS NOT TO EXCEED .15 MM (.006").
- CONTROLLING DIMENSION: MILLIMETERS.
- MEETS JEDEC MO150.
- LEADS TO BE COPLANAR WITHIN 0.10 MM.

DALLAS SEMICONDUCTOR **MAXIM**

PROPRIETARY INFORMATION

TITLE:
PACKAGE OUTLINE, SSOP, 5.3 MM



APPROVAL	DOCUMENT CONTROL NO. 21-0056	REV. C	1/1
----------	---------------------------------	-----------	-----

Maxim cannot assume responsibility for use of any circuitry other than circuitry entirely embodied in a Maxim product. No circuit patent licenses are implied. Maxim reserves the right to change the circuitry and specifications without notice at any time.

Maxim Integrated Products, 120 San Gabriel Drive, Sunnyvale, CA 94086 408-737-7600 13

Looking for pricing, stock, or lifecycle information?

Click below to explore more details on WIN SOURCE:

-  View [MAX6968AAE+](#) on WIN SOURCE
-  [Maxim Integrated](#) Information

Optimize Your Supply Chain with WIN SOURCE Solutions

-  Global Sourcing Solution
-  Obsolete Management
-  Cost Control Management
-  Shortage Management
-  Alternative Solution
-  Excess Inventory Management