



THE DATASHEET OF
4268-00



PE4268

**SP6T UltraCMOS™ 2.6 V Switch
100 – 3000 MHz**

Features

- Three pin CMOS logic control with integral decoder/driver
- Low TX insertion loss: 0.55 dB at 900 MHz, 0.7 dB at 1900 MHz
- TX – RX Isolation of 48 dB at 900 MHz, 40 dB at 1900 MHz
- Low harmonics: $2f_o = -84$ dBc and $3f_o = -70$ dBc at +35 dBm input power
- 1500 V HBM ESD tolerance
- RX SAW over voltage protection circuit
- Harmonics immune to RX VSWR
- No blocking capacitors required
- 20-lead 4x4 mm QFN package

Product Description

The PE4268 SP6T RF UltraCMOS™ Switch addresses the specific design needs of the Quad-Band GSM Handset Antenna Switch Module Market. Broadband performance also makes it a versatile solution in other IF and RF applications. The switch includes two high power paths with low insertion loss and four low power paths with high isolation. On-chip CMOS decode logic facilitates three-pin low voltage CMOS control. High ESD tolerance of 1500 V at all ports and no blocking capacitor requirements make this the ultimate in integration and ruggedness.

The PE4268 UltraCMOS™ RF Switch is manufactured in Peregrine's patented Ultra Thin Silicon (UTSi®) CMOS process, offering the performance of GaAs with the economy and integration of conventional CMOS.

Figure 1. Functional Diagram

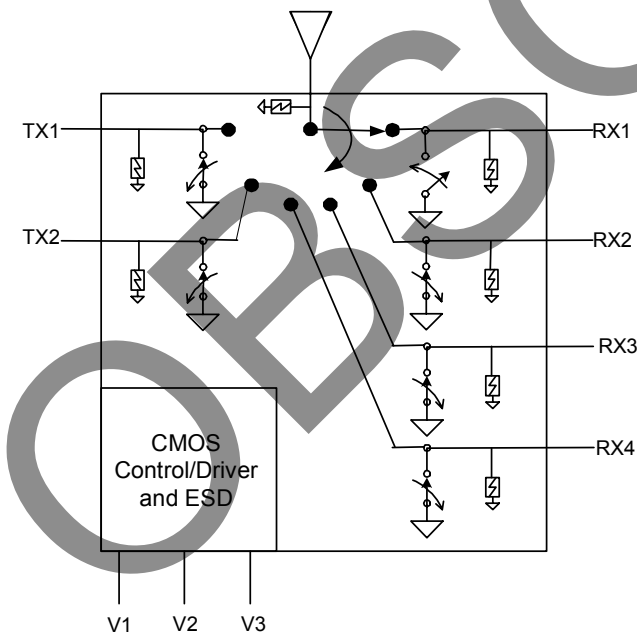

Figure 2. Package Type

20-lead 4x4 mm QFN



Table 1. Electrical Specifications @ +25 °C, V_{DD} = 2.6 V (Z_S = Z_L = 50 Ω)

Parameter	Condition	Min	Typ	Max	Unit
Operational Frequency		100		3000	MHz
Insertion Loss	ANT - TX - 850 / 900 MHz		0.6	0.75	dB
	ANT - TX - 1800 / 1900 MHz		0.8	0.95	dB
	ANT - RX - 850 / 900 MHz		0.9	1.15	dB
	ANT - RX - 1800 / 1900 MHz		1.1	1.35	dB
Isolation	TX - RX - 850 / 900 MHz	46	50		dB
	TX - RX - 1800 / 1900 MHz	38	42		dB
	TX1 - TX2 - 850 / 900 MHz	28	30		dB
	TX1 - TX2 - 1800 / 1900 MHz	22	24		dB
Return Loss	850 / 900 MHz	17	20		dB
	1800 / 1900 MHz	15	18		dB
2nd Harmonic ¹	35 dBm TX Input - 850 / 900 MHz		-84	-78	dBc
	33 dBm TX Input - 1800 / 1900 MHz		-80	-77	dBc
3rd Harmonic ¹	35 dBm TX Input - 850 / 900 MHz		-70	-68	dBc
	33 dBm TX Input - 1800 / 1900 MHz		-66	-63	dBc
IP3	RX Input		40		dBm
1dB Compression	RX Input	20			dBm
Switching time	(10-90%) (90-10%) RF		2	3	µs

Note : 1. Harmonics are characterized with a source that is 50 Ω at the fundamental and reflective at the harmonics. Contact Applications Support at help@psemi.com for more information.

Figure 3. Pin Configuration (Top View)

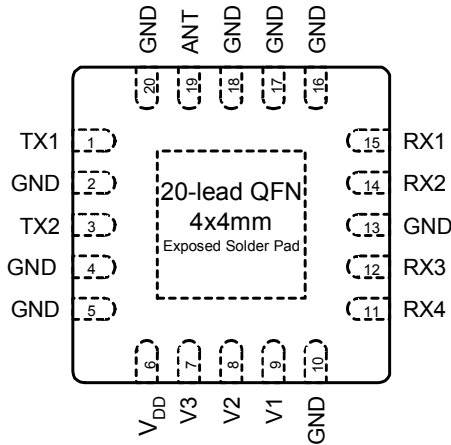

Table 2. Pin Descriptions

Pin No.	Pin Name	Description
1 ¹	TX1	RF I/O - TX1
2	GND	Ground
3 ¹	TX2	RF I/O - TX2
4	GND	Ground
5	GND	Ground
6	VDD	Supply
7	V3	Switch control input, CMOS logic level
8	V2	Switch control input, CMOS logic level
9	V1	Switch control input, CMOS logic level
10	GND	Ground
11 ¹	RX4	RF I/O - RX4
12 ¹	RX3	RF I/O - RX3
13	GND	Ground
14 ¹	RX2	RF I/O - RX2
15 ¹	RX1	RF I/O - RX1
16	GND	Ground
17	GND	Ground
18	GND	Ground
19 ¹	ANT	RF Common - Antenna Input
20	GND	Ground

Note 1: Blocking capacitors needed only when connected to an external non-zero DC voltage.

Table 3. DC Electrical Specifications

Parameter	Min	Typ	Max	Units
V _{DD} Supply Voltage	2.4	2.6	2.8	V
I _{DD} Power Supply Current (V _{DD} = 2.6V)		13	20	μA
Control Voltage High	0.7 x V _{DD}			V
Control Voltage Low			0.3 x V _{DD}	V

Table 4. Absolute Maximum Ratings

Symbol	Parameter/Conditions	Min	Max	Units
V _{DD}	Power supply voltage	-0.3	4.0	V
V _I	Voltage on any input	-0.3	V _{DD} +0.3	V
T _{ST}	Storage temperature range	-65	+150	°C
T _{OP}	Operating temperature range	-40	+85	°C
P _{IN}	TX input power (50 Ω)		+38	dBm
	RX input power (50 Ω)		+23	
V _{ESD} ¹	ESD Voltage (HBM, MIL-STD 883 Method 3015.7)		1500	V
	ESD Voltage (MM, JEDEC, JESD22-A114-B)		100	V
	ESD Voltage (CDM, JEDEC, JESD22-C101-A)		2000	V

Note 1: ANT port rated higher per applications section, see page 4.

Absolute Maximum Ratings are those values listed in the above table. Exceeding these values may cause permanent device damage. Functional operation should be restricted to the limits in the DC Electrical Specifications table. Exposure to absolute maximum ratings for extended periods may affect device reliability.

Electrostatic Discharge (ESD) Precautions

When handling this UltraCMOS™ device, observe the same precautions that you would use with other ESD-sensitive devices. Although this device contains circuitry to protect it from damage due to ESD, precautions should be taken to avoid exceeding the rating specified in Table 4.

Latch-Up Avoidance

Unlike conventional CMOS devices, UltraCMOS™ devices are immune to latch-up.

Table 5. Truth Table

Path	V3	V2	V1
ANT - RX1	0	0	0
ANT - RX2	0	0	1
ANT - RX3	0	1	0
ANT - RX4	0	1	1
ANT - TX1	1	0	x
ANT - TX2	1	1	x

Evaluation Kit

The SP6T Evaluation Kit board was designed to ease customer evaluation of the PE4268 RF switch.

The PE4268 has two high power TX ports and four high isolation RX ports. The TX ports are symmetric and are designed as paths for the 850, 900, 1800, or 1900 MHz bands. The RX ports are also symmetric and can be assigned to any of these frequency bands.

The ANT port connects through a 50 Ω transmission line to the top SMA connector, J1. The RX and TX ports connect through 50 Ω transmission lines to SMA connectors J2 – J7. A through 50 Ω transmission line between SMA connectors J9 and J10 allows estimation of the PCB losses over environmental conditions. An open transmission line connected to J11 is also provided.

J8 supplies DC power to the pin marked V_{DD} and the bottom row of pins, which is GND. 1 M Ω pull-up resistors are connected from V_{DD} to each of the three control logic inputs: V1, V2, and V3. These pull-up resistors are provided for ease of evaluation on this board and are not required for the PE4268 to operate.

Adding a jumper between a control pin and the adjacent GND pin on the bottom row of J8 will set a logic-0 on that control pin. Removing the jumper will set a logic-1. To evaluate the PE4268, add or remove jumpers according to the truth table in Table 5.

Figure 4. Evaluation Board Layout

Peregrine Specification 101/0205

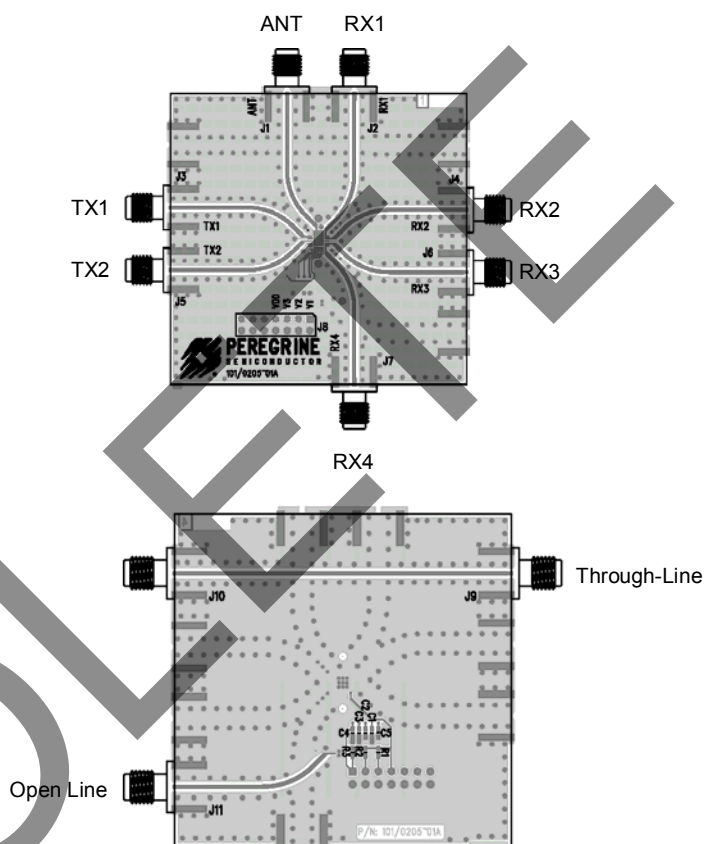
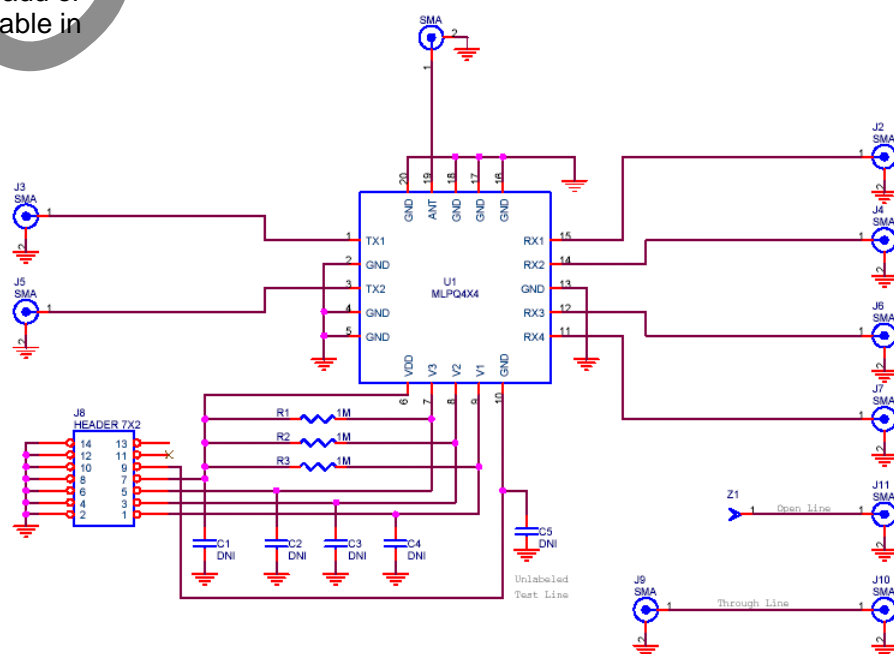

Figure 5. Evaluation Board Schematic

Peregrine Specification 102/0267



Typical Performance Data @ $V_{DD} = 2.6\text{ V}$, $25\text{ }^{\circ}\text{C}$ (Unless otherwise noted)

Figure 6. Insertion Loss: All Ports

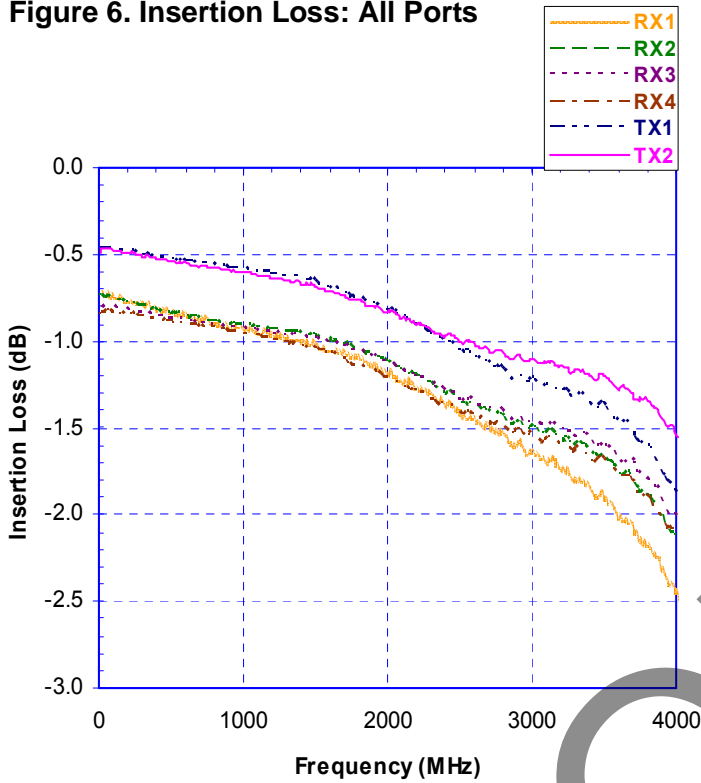

Figure 7. Insertion Loss: TX Over V_{DD}

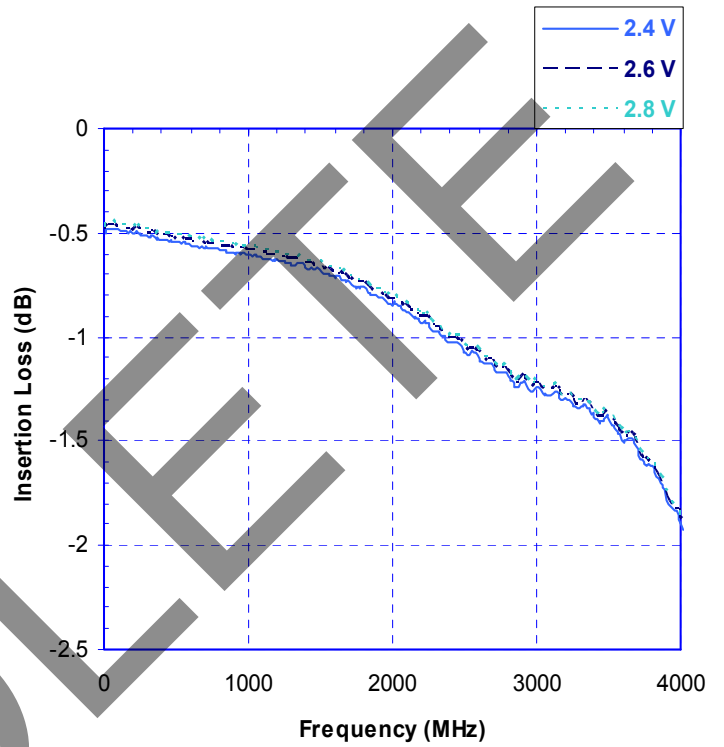

Figure 8. Insertion Loss: TX Over Temp

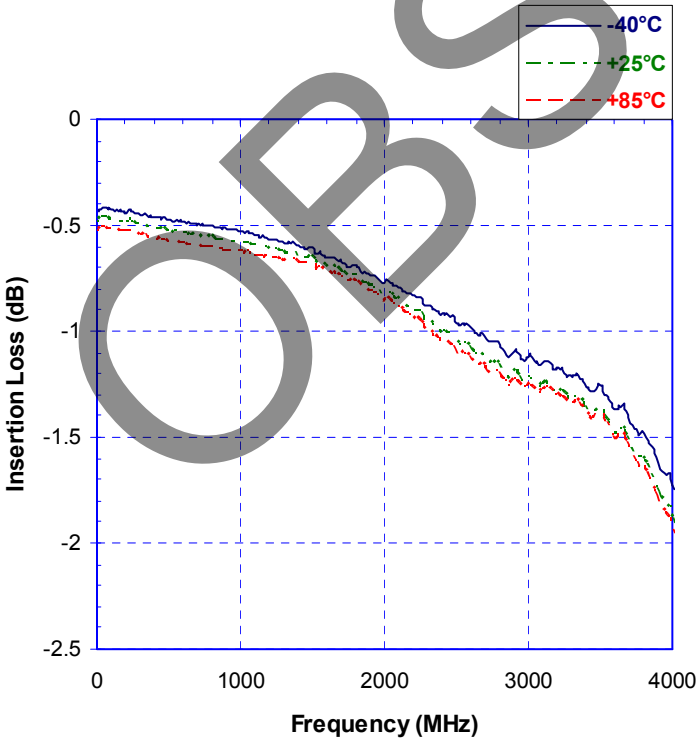
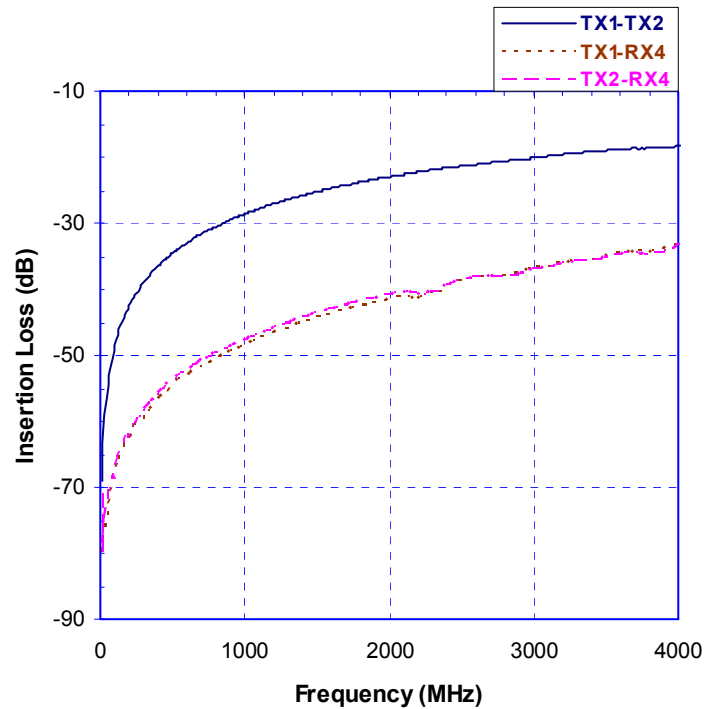

Figure 9. Isolation: Worst Case Paths



Typical Performance Data @ $V_{DD} = 2.6\text{ V}$, $25\text{ }^\circ\text{C}$ (Unless otherwise noted)

Figure 10. Return Loss: Worse Case Paths

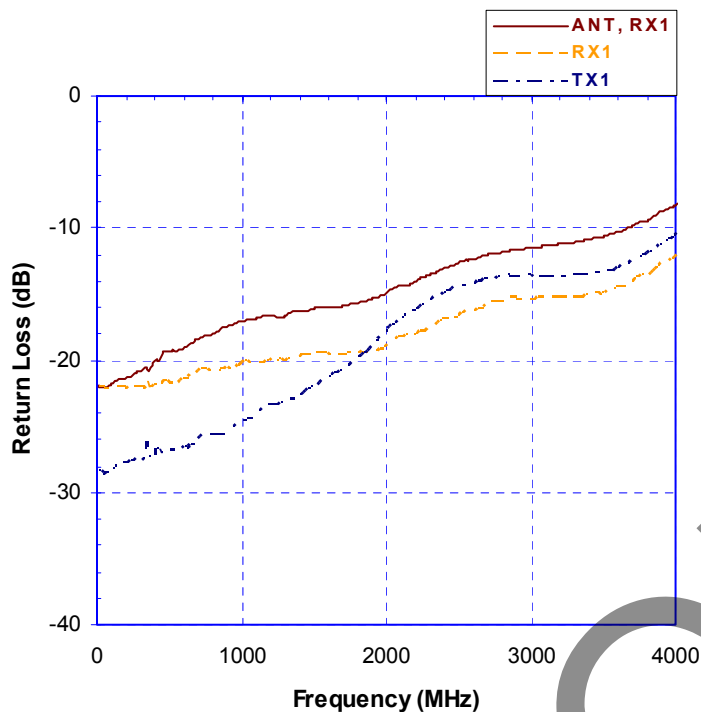

Figure 11. TX Harmonics 915MHz Over V_{DD}

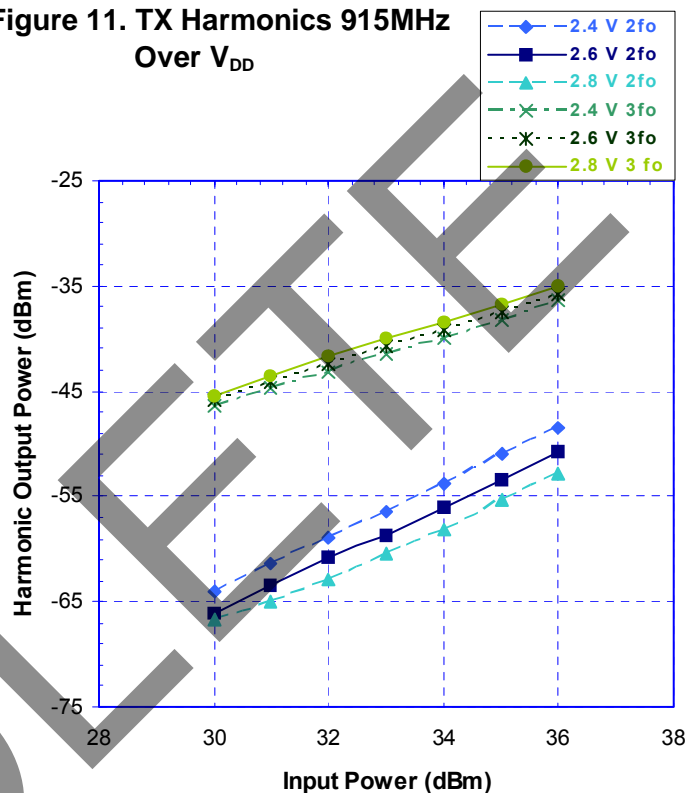

Figure 12. TX Harmonics 915MHz Over Temp

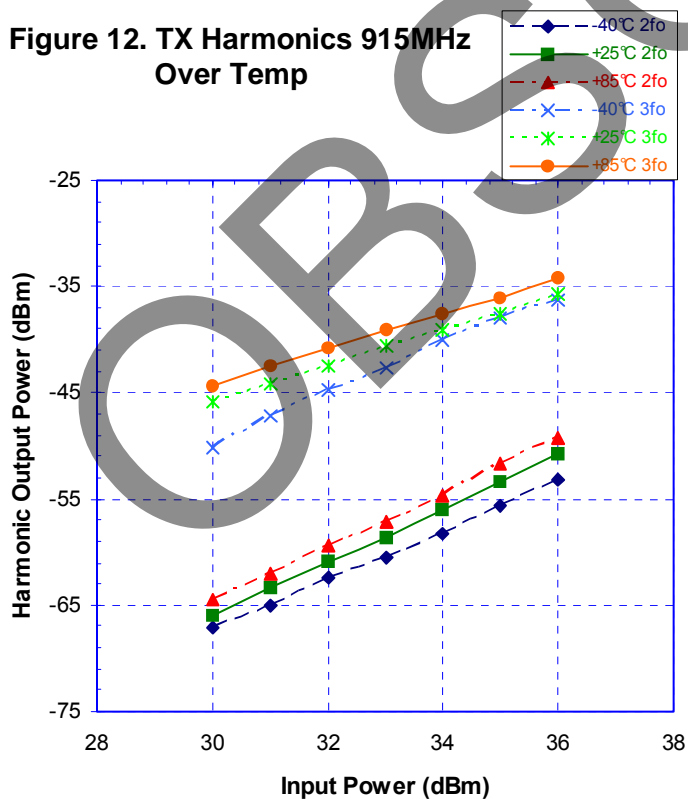
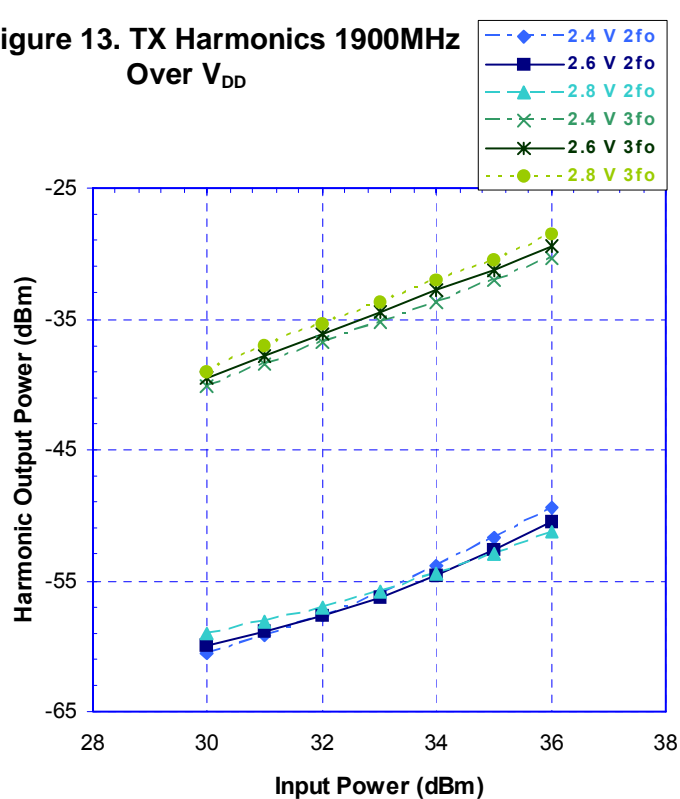
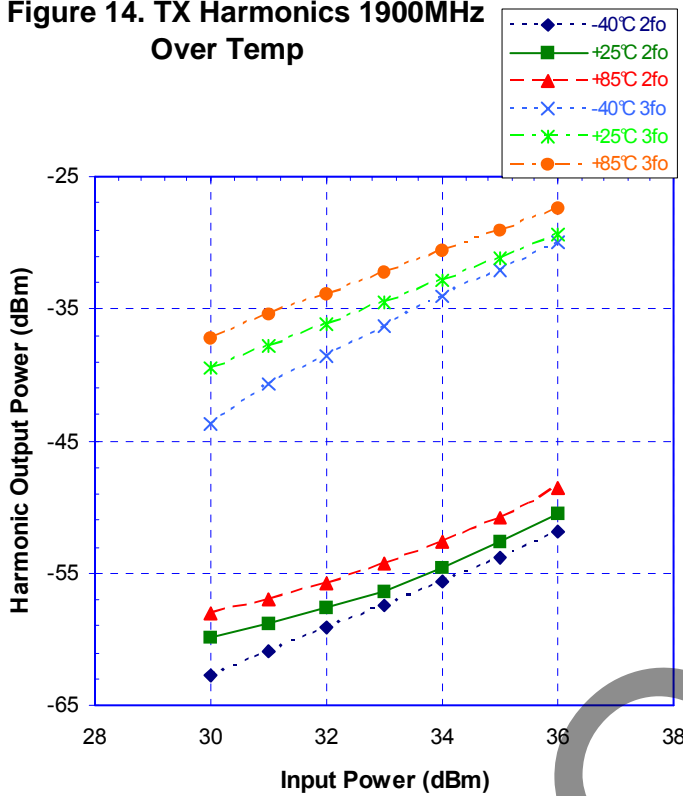

Figure 13. TX Harmonics 1900MHz Over V_{DD}



Typical Performance Data @ $V_{DD} = 2.6\text{ V}$, $25\text{ }^{\circ}\text{C}$ (Unless otherwise noted)

Figure 14. TX Harmonics 1900MHz
Over Temp



OBSOLETE

Figure 15. Package Drawing (mm)

20-lead 4x4 mm QFN

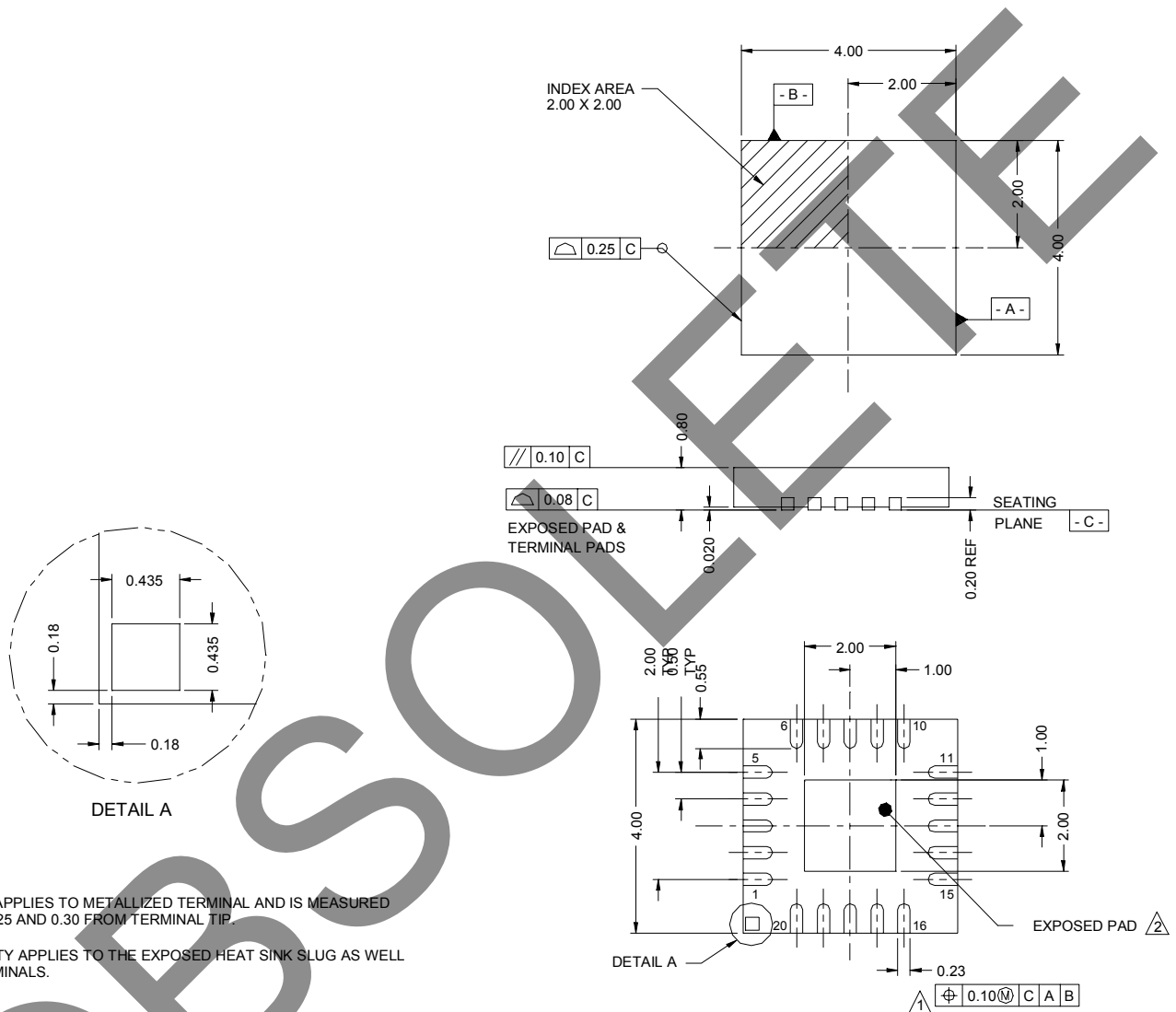

1. DIMENSION APPLIES TO METALLIZED TERMINAL AND IS MEASURED BETWEEN 0.25 AND 0.30 FROM TERMINAL TIP.
2. COPLANARITY APPLIES TO THE EXPOSED HEAT SINK SLUG AS WELL AS THE TERMINALS.

Figure 16. Marking Specification



Figure 17. Tape and Reel Drawing

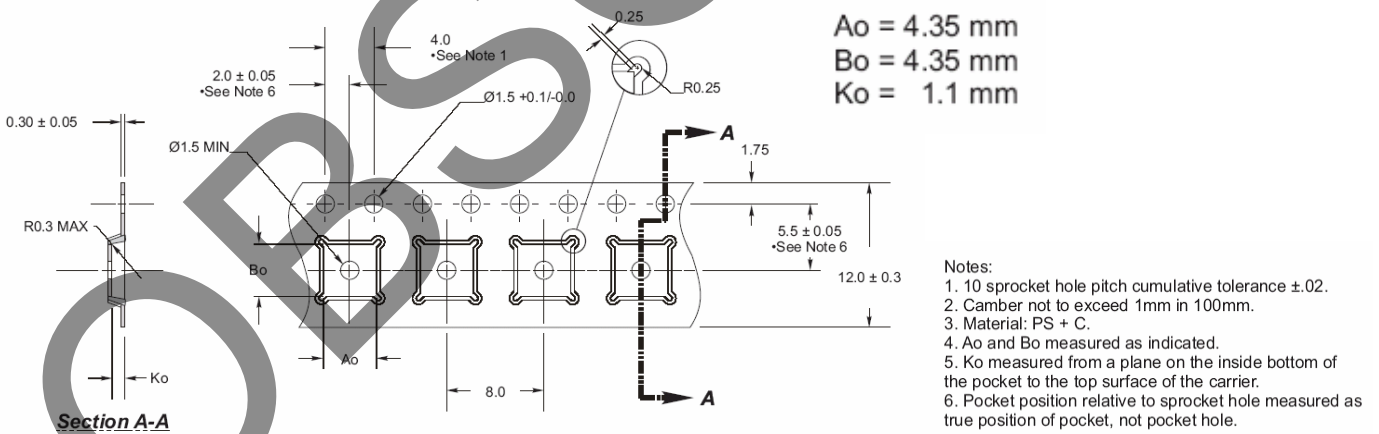

ESD Protection Circuit

Handset products must tolerate large ESD surges at the antenna interface without damage. The IEC 61000-4-2 standard specifies both 8 kV contact and 16 kV air discharges that typical handsets must survive. By itself, the PE4268 offers protection to 1.5 kV but with the addition of two inexpensive passive components, the switch can meet the levels as specified in the IEC spec. Figure 18 is the suggested solution for compliance with the IEC standards.

Figure 18. ESD Protection Circuit

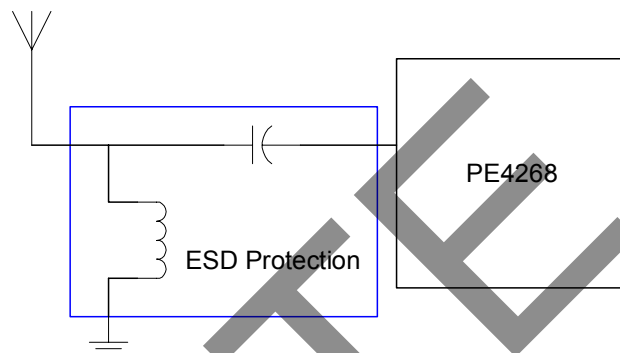

L = 27 nH (muRata: LQG1127NJ00),

C = 33 pF (muRata: GRM33C0G330J50)

Table 6. PE4268 Antenna Application Test Results (C=150 pF, R=330 Ω, IEC 61000-4-2 Standard)

Test Condition	Results
+8 kV contact discharge, 10 times with 1s intervals	Pass
-8 kV contact discharge, 10 times with 1s intervals	Pass
+16 kV air discharge, 10 times with 1s intervals	Pass
-16 kV air discharge, 10 times with 1s intervals	Pass

Table 7. Ordering Information

Order Code	Part Marking	Description	Package	Shipping Method
4268-01	4268	PE4268-20QFN 4x4mm-75A	20-lead 4x4mm QFN	75 units / Tube
4268-02	4268	PE4268-20QFN 4x4mm-3000C	20-lead 4x4mm QFN	3000 units / T&R
4268-00	PE4268-EK	PE4268-20QFN 4x4mm-EK	Evaluation Kit	1 / Box
4268-51	4268	PE4268G-20QFN 4x4mm-75A	Green 20-lead 4x4mm QFN	75 units / Tube
4268-52	4268	PE4268G-20QFN 4x4mm-3000C	Green 20-lead 4x4mm QFN	3000 units / T&R

Sales Offices

The Americas

Peregrine Semiconductor Corporation

9450 Carroll Park Drive
San Diego, CA 92121
Tel 858-731-9400
Fax 858-731-9499

Europe

Peregrine Semiconductor Europe

Bâtiment Maine
13-15 rue des Quatre Vents
F- 92380 Garches, France
Tel: +33-1-47-41-91-73
Fax : +33-1-47-41-91-73

Space and Defense Products

Americas:

Tel: 505-881-0438
Fax: 505-881-0443

Europe, Asia Pacific:

180 Rue Jean de Guiramand
13852 Aix-En-Provence cedex 3, France
Tel: +33(0) 4 4239 3361
Fax: +33(0) 4 4239 7227

For a list of representatives in your area, please refer to our Web site at: www.psemi.com

Data Sheet Identification

Advance Information

The product is in a formative or design stage. The data sheet contains design target specifications for product development. Specifications and features may change in any manner without notice.

Preliminary Specification

The data sheet contains preliminary data. Additional data may be added at a later date. Peregrine reserves the right to change specifications at any time without notice in order to supply the best possible product.

Product Specification

The data sheet contains final data. In the event Peregrine decides to change the specifications, Peregrine will notify customers of the intended changes by issuing a DCN (Document Change Notice).

North Asia Pacific

Peregrine Semiconductor K.K.

5A-5, 5F Imperial Tower
1-1-1 Uchisaiwaicho, Chiyoda-ku
Tokyo 100-0011 Japan
Tel: +81-3-3502-5211
Fax: +81-3-3502-5213

Peregrine Semiconductor, Korea

#B-2402, Kolon Tripolis, #210
Geumgok-dong, Bundang-gu, Seongnam-si
Gyeonggi-do, 463-480 S. Korea
Tel: +82-31-728-4300
Fax: +82-31-728-4305

South Asia Pacific

Peregrine Semiconductor, China

Shanghai, 200040, P.R. China
Tel: +86-21-5836-8276
Fax: +86-21-5836-7652

The information in this data sheet is believed to be reliable. However, Peregrine assumes no liability for the use of this information. Use shall be entirely at the user's own risk.

No patent rights or licenses to any circuits described in this data sheet are implied or granted to any third party.

Peregrine's products are not designed or intended for use in devices or systems intended for surgical implant, or in other applications intended to support or sustain life, or in any application in which the failure of the Peregrine product could create a situation in which personal injury or death might occur. Peregrine assumes no liability for damages, including consequential or incidental damages, arising out of the use of its products in such applications.

The Peregrine name, logo, and UTSi are registered trademarks and UltraCMOS and HaRP are trademarks of Peregrine Semiconductor Corp.

Looking for pricing, stock, or lifecycle information?

Click below to explore more details on WIN SOURCE:

- ⊖ [View 4268-00 on WIN SOURCE](#)
- ⊖ [Peregrine Semiconductor](#) Information

Optimize Your Supply Chain with WIN SOURCE Solutions

- ✓ Global Sourcing Solution
- ✓ Obsolete Management
- ✓ Cost Control Management
- ✓ Shortage Management
- ✓ Alternative Solution
- ✓ Excess Inventory Management