

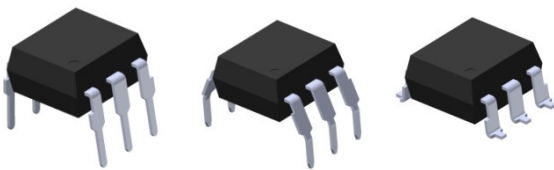

THE DATASHEET OF 4N31M



6 PIN DIP PHOTODARLINGTON PHOTOCOUPLER TIL113, 4NXX, H11BX Series



Features:

- 4NXX series: 4N29, 4N30, 4N31, 4N32, 4N33
- H11BX series: H11B1, H11B2, H11B3, H11B255
- High isolation voltage between input and output (Viso=5000 V rms)
- Creepage distance >7.62 mm
- Operating temperature up to +110 °C
- Compact small outline package
- Pb free and RoHS compliant.
- UL approved (No. E214129)
- VDE approved (No. 132249)
- SEMKO approved
- NEMKO approved
- DEMKO approved
- FIMKO approved
- CSA approved

Description

The TIL113, 4NXX and H11BX series of devices each consist of an infrared emitting diode optically coupled to a photo darlington detector.

They are packaged in a 6-pin DIP package and available in wide-lead spacing and SMD option.

Applications

- Low power logic circuits
- Telecommunications equipment
- Portable electronics
- Interfacing coupling systems of different potentials and impedances

Schematic

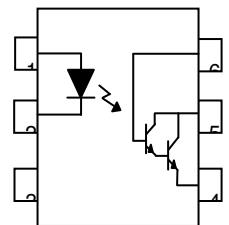

Pin Configuration

1. Anode
2. Cathode
3. No Connection
4. Emitter
5. Collector
6. Base

Absolute Maximum Ratings (Ta=25°C)

	Parameter	Symbol	Rating	Unit
Input	Forward current	I_F	60	mA
	Peak forward current (1us, pulse)	I_{FP}	1	A
	Reverse voltage	V_R	6	V
	Power dissipation No derating required up to Ta = 100°C	P_D	120 3.8	mW mW/°C
Output	Power dissipation Derating factor (above Ta = 80°C)	P_C	150 6.5	mW mW/°C
	Collector-Emitter voltage	V_{CEO}	55	V
	Collector-Base voltage	V_{CBO}	55	V
	Emitter-Collector voltage	V_{ECO}	7	V
	Emitter-Base voltage	V_{EBO}	7	V
	Total power dissipation	P_{TOT}	200	mW
Isolation voltage	V_{ISO}	5000	Vrms	
Operating temperature	T_{OPR}	-55~+100	°C	
Storage temperature	T_{STG}	-55~+125	°C	
Soldering temperature *2	T_{SOL}	260	°C	

Notes:

*1 AC for 1 minute, R.H.= 40 ~ 60% R.H. In this test, pins 1, 2 & 3 are shorted together, and pins 4, 5 & 6 are shorted together.

*2 For 10 seconds

Electro-Optical Characteristics (Ta=25°C unless specified otherwise)

Input

Parameter	Symbol	Min.	Typ.*	Max.	Unit	Condition
Forward Voltage	V_F	-	1.2	1.5	V	$I_F = 10\text{mA}$ $I_F = 50\text{mA}$ for H11B3
Reverse Current	I_R	-	-	10	μA	$V_R = 6\text{V}$
Input capacitance	C_{in}	-	50	-	pF	$V = 0, f = 1\text{MHz}$

Output

Parameter	Symbol	Min.	Typ.*	Max.	Unit	Condition
Collector-Emitter dark current	I_{CEO}	-	-	100	nA	$V_{CE} = 10\text{V}$
Collector-Emitter breakdown voltage	BV_{CEO}	55	-	-	V	$I_C = 1\text{mA}$
Emitter-Collector breakdown voltage	BV_{CBO}	55	-	-	V	$I_C = 0.1\text{mA}$
Emitter-Collector breakdown voltage	BV_{ECO}	7	-	-	V	$I_E = 0.1\text{mA}$

Transfer Characteristics (Ta=25°C unless specified otherwise)

Parameter	Symbol	Min	Typ.	Max.	Unit	Condition	
Current transfer ratio	4N32 4N33	500	-	-	%	$I_F = 10\text{mA}, V_{CE} = 10\text{V}$	
	4N29 4N30	100	-	-			
	4N31	50	-	-			
	H11B1	500	-	-			
	H11B2	200	-	-			$I_F = 1\text{mA}, V_{CE} = 5\text{V}$
	H11B3	100	-	-			
	H11B255	100	-	-			$I_F = 10\text{mA}, V_{CE} = 5\text{V}$
	TIL113	300	-	-			$I_F = 10\text{mA}, V_{CE} = 1\text{V}$

Transfer Characteristics ($T_a=25^\circ\text{C}$ unless specified otherwise)

Parameter	Symbol	Min	Typ.	Max.	Unit	Condition
Collector-emitter saturation voltage	4N29 4N30 4N32 4N33	-	-	1.0	V	$I_F = 8\text{mA}, I_C = 2\text{mA}$
	4N31 TIL113	-	-	1.2		
	H11B1 H11B2 H11B3	-	-	1.0		
	H11B255	-	-	1.0		
Isolation resistance	R_{IO}	10^{11}	-	-	Ω	$V_{IO} = 500\text{Vdc}$
Input-output Capacitance	C_{IO}	-	0.8	-	pF	$V_{IO} = 0, f = 1\text{MHz}$
Turn-on time	H11B1 H11B2 H11B3 H11B255	-	25	-	μs	$V_{CC} = 10\text{V}, I_F = 10\text{mA}, R_L = 100\Omega$
	4N29 4N30 4N31 4N32 4N33 TIL113	-	-	5		
Turn-off time	H11B1 H11B2 H11B3 H11B255	-	18	-	μs	$V_{CC} = 10\text{V}, I_F = 10\text{mA}, R_L = 100\Omega$
	4N32 4N33 TIL113 4N29 4N30 4N31	-	-	100		
				40		$V_{CC} = 10\text{V}, I_C = 50\text{mA}, I_F = 200\text{mA}$

* Typical values at $T_a = 25^\circ\text{C}$

Typical Electro-Optical Characteristics Curves

Figure 1. Forward Current vs Forward Voltage

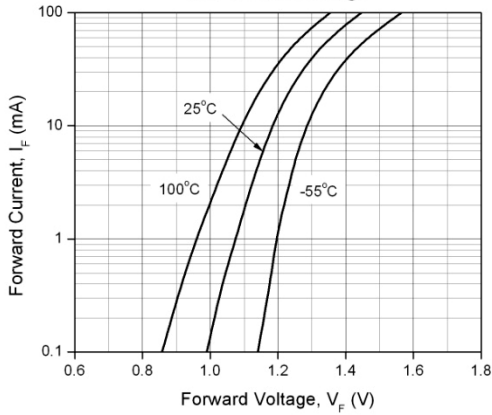

Figure 2. Current Transfer Ratio vs. Ambient Temperature

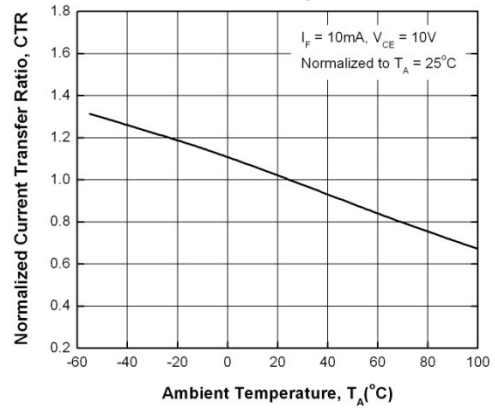

Figure 3. Normalized Current Transfer Ratio vs Forward Current

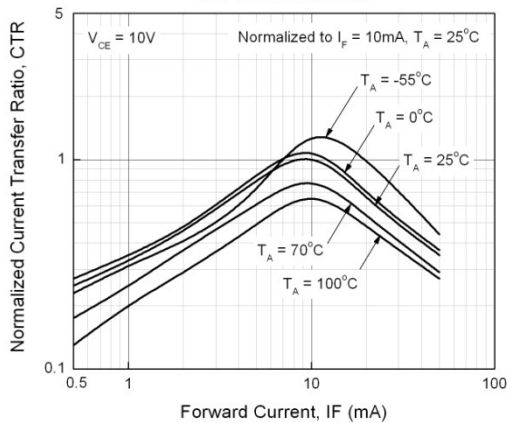

Figure 4. Collector Dark Current vs Ambient Temperature

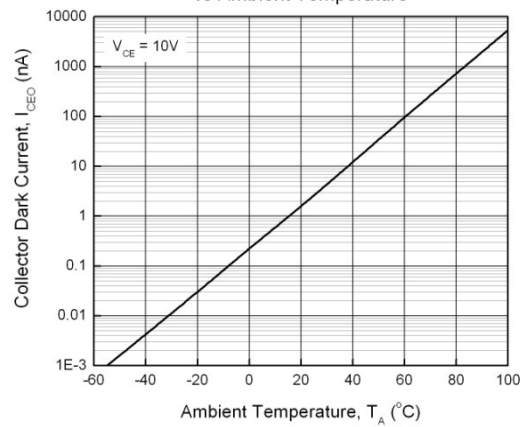

Figure 5. Turn-on Time vs Forward Current

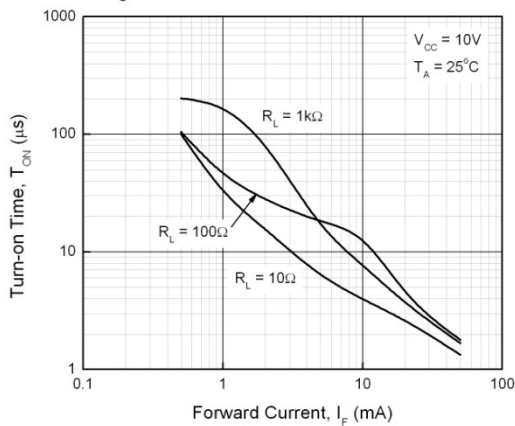
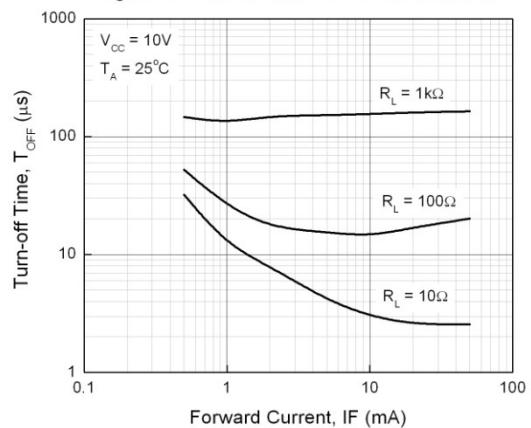

Figure 6. Turn-off Time vs Forward Current



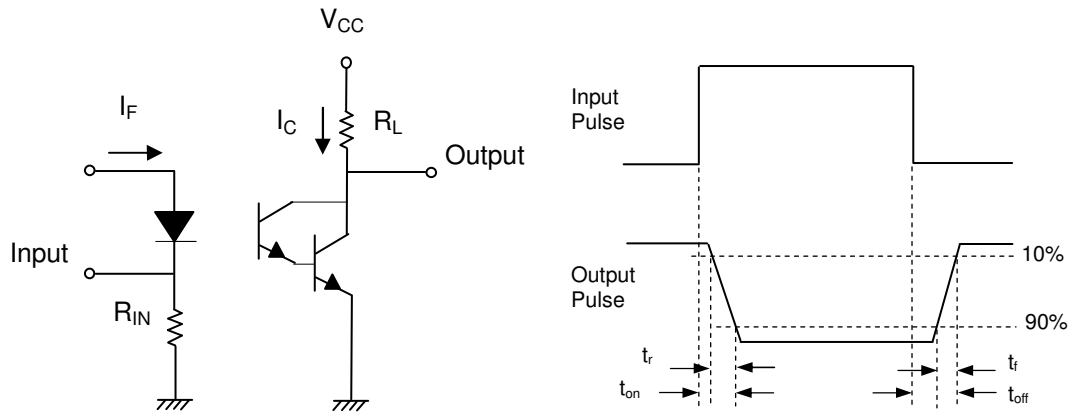

Figure 7. Switching Time Test Circuit & Waveforms

Order Information

Part Number

4NXXY(Z)-V
or **H11BXY(Z)-V**
or **TIL113Y(Z)-V**

Note

XX = Part No. for 4NX series (29, 30, 31, 32 or 33)
X = Part No. for H11BX series (1, 2, 3 or 255)
Y = Lead form option (S, S1, M or none)
Z = Tape and reel option (TA, TB or none).
V = VDE safety (optional)

Option	Description	Packing quantity
None	Standard DIP-6	65 units per tube
M	Wide lead bend (0.4 inch spacing)	65 units per tube
S (TA)	Surface mount lead form + TA tape & reel option	1000 units per reel
S (TB)	Surface mount lead form + TB tape & reel option	1000 units per reel
S1 (TA)	Surface mount lead form (low profile) + TA tape & reel option	1000 units per reel
S1 (TB)	Surface mount lead form (low profile) + TB tape & reel option	1000 units per reel

Package Dimension (Dimensions in mm)

Standard DIP Type

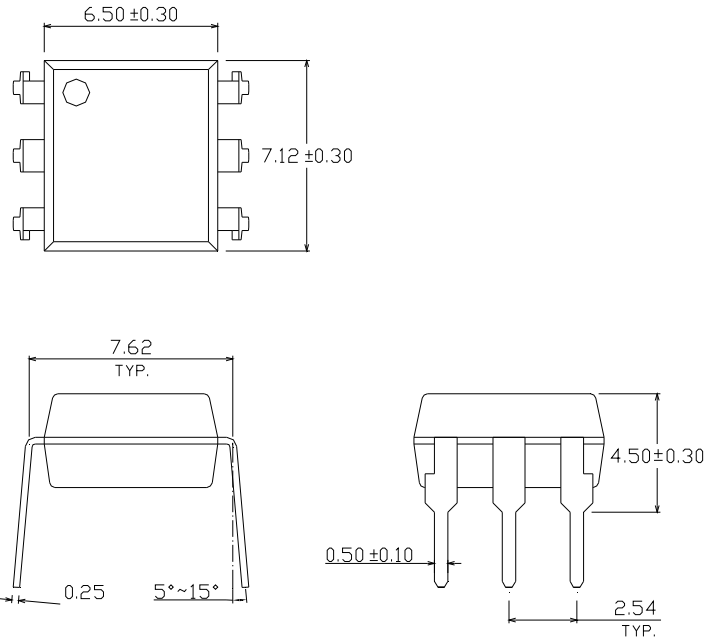

Option M Type

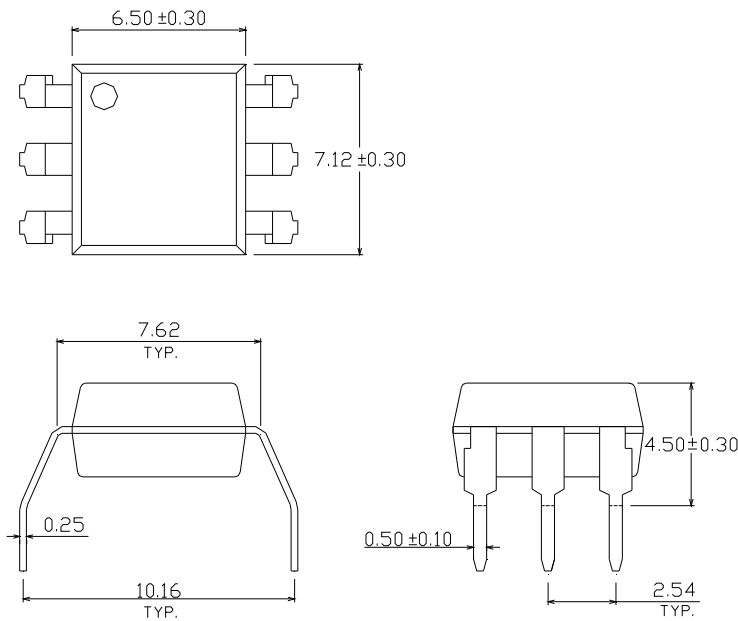

Option S Type

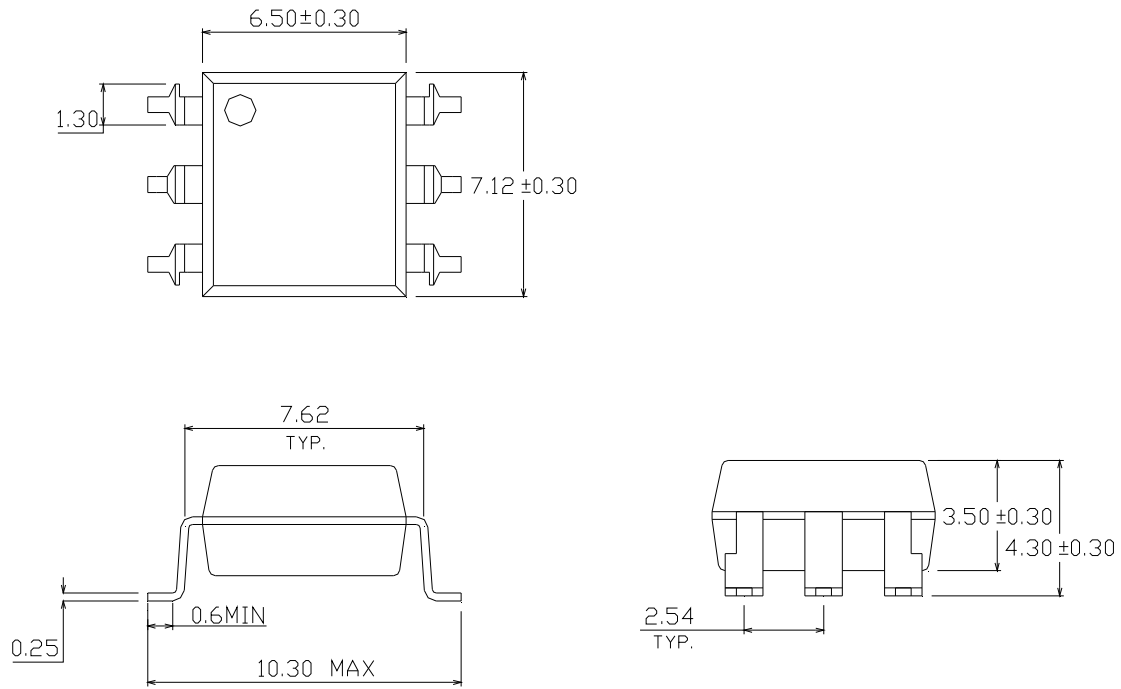

Option S1 Type

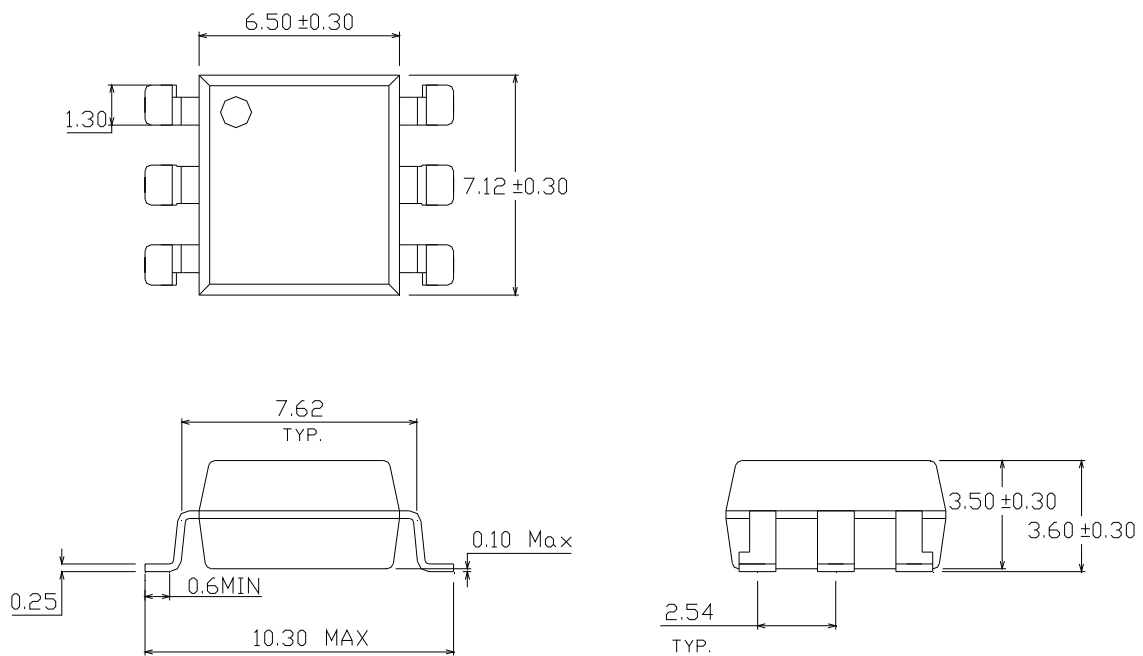

Recommended pad layout for surface mount leadform

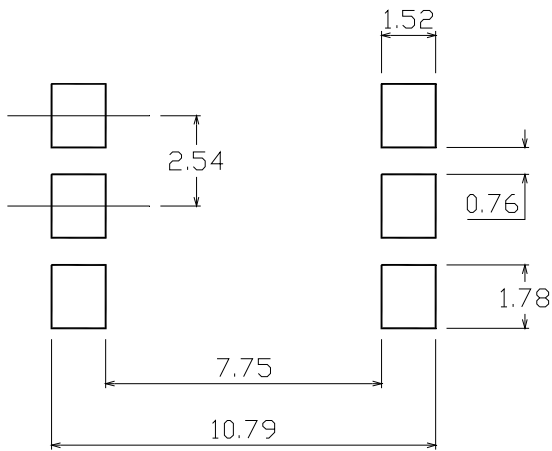

Device Marking

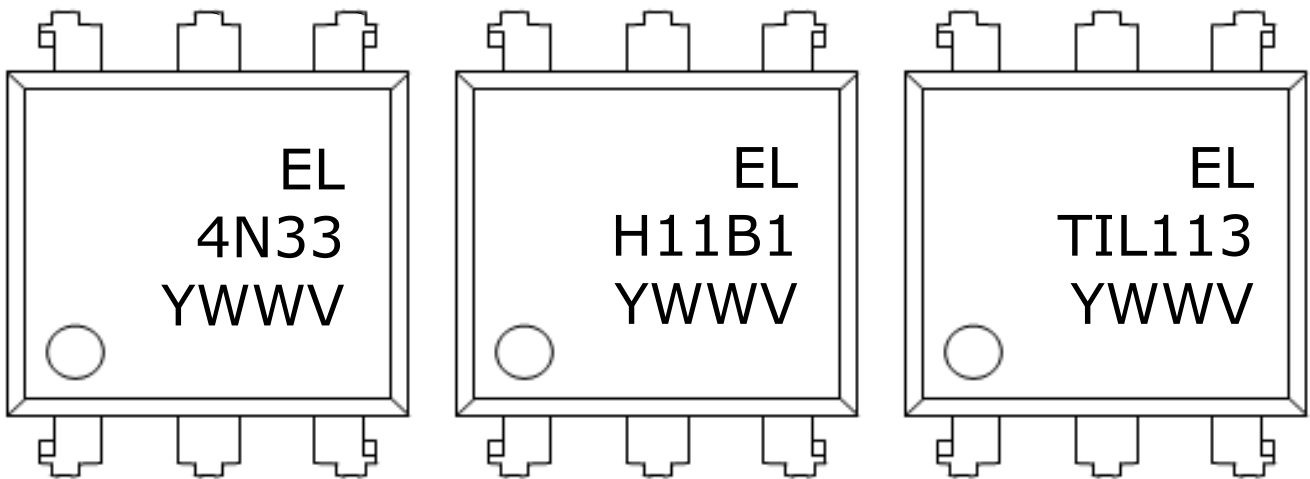

Notes

- EL denotes Everlight
- 4N33
- TIL113
- H11B1 denotes Part Number
- Y denotes 1 digit Year code
- WW denotes 2 digit Week code
- V denotes VDE safety (optional)

Tape & Reel Packing Specifications

Option TA

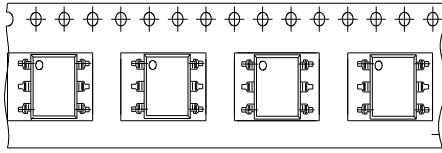

Direction of feed from reel

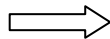

Option TB

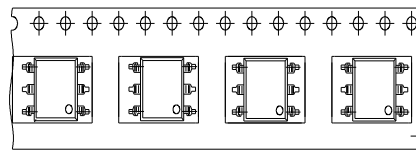

Direction of feed from reel

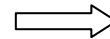

Tape dimensions

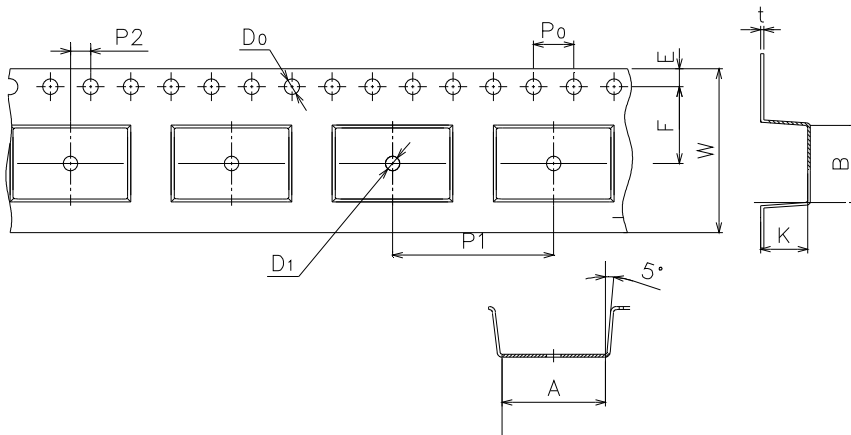

Dimension No.	A	B	Do	D1	E	F
Dimension(mm)	10.4±0.1	7.5±0.1	1.5±0.1	1.5+0.1/-0	1.75±0.1	7.5±0.1
Dimension No.	Po	P1	P2	t	W	K
Dimension(mm)	4.0±0.15	12±0.1	2.0±0.1	0.35±0.03	16.0±0.2	4.5±0.1

Precautions for Use

1. Soldering Condition

1.1 (A) Maximum Body Case Temperature Profile for evaluation of Reflow Profile

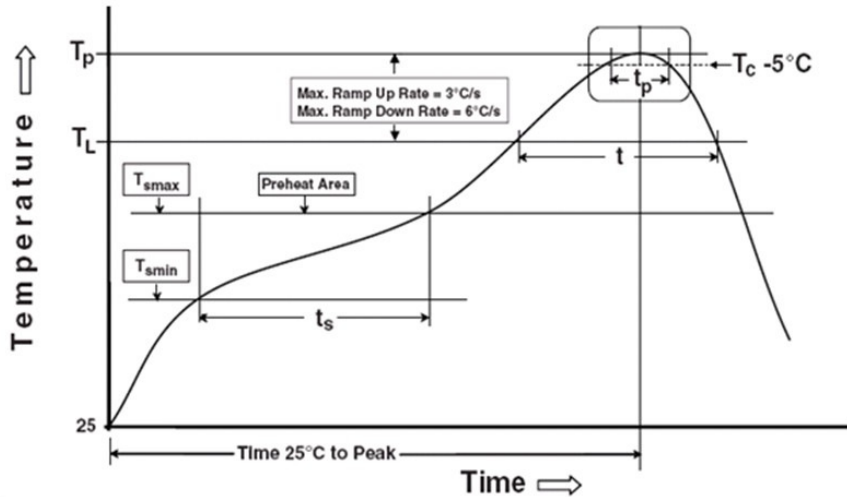

Note:

Reference: IPC/JEDEC J-STD-020D

Preheat

Temperature min (T_{smin})	150 °C
Temperature max (T_{smax})	200 °C
Time (T_{smin} to T_{smax}) (t_s)	60-120 seconds
Average ramp-up rate (T_{smax} to T_p)	3 °C/second max

Other

Liquidus Temperature (T_L)	217 °C
Time above Liquidus Temperature (t_L)	60-100 sec
Peak Temperature (T_p)	260 °C
Time within 5 °C of Actual Peak Temperature: $T_p - 5^\circ\text{C}$	30 s
Ramp- Down Rate from Peak Temperature	6 °C /second max.
Time 25 °C to peak temperature	8 minutes max.
Reflow times	3 times

DISCLAIMER

1. Above specification may be changed without notice. EVERLIGHT will reserve authority on material change for above specification.
2. When using this product, please observe the absolute maximum ratings and the instructions for using outlined in these specification sheets. EVERLIGHT assumes no responsibility for any damage resulting from use of the product which does not comply with the absolute maximum ratings and the instructions included in these specification sheets.
3. These specification sheets include materials protected under copyright of EVERLIGHT corporation. Please don't reproduce or cause anyone to reproduce them without EVERLIGHT's consent.

Looking for pricing, stock, or lifecycle information?

Click below to explore more details on WIN SOURCE:

- [View 4N31M on WIN SOURCE](#)
- [Everlight Electronics Co Ltd Information](#)

Optimize Your Supply Chain with WIN SOURCE Solutions

- ✓ Global Sourcing Solution
- ✓ Obsolete Management
- ✓ Cost Control Management
- ✓ Shortage Management
- ✓ Alternative Solution
- ✓ Excess Inventory Management