



**THE DATASHEET OF  
LMH6554LEE/NOPB**



## LMH6554 2.8-GHz Ultra Linear Fully Differential Amplifier

### 1 Features

- Small-Signal Bandwidth 2.8 GHz
- 2 V<sub>PP</sub> Large-Signal Bandwidth 1.8 GHz
- 0.1 dB Gain Flatness 830 MHz
- OIP3 at 150 MHz 46.5 dBm
- HD2/HD3 at 75 MHz –96 / –97 dBc
- Input Noise Voltage 0.9 nV/√Hz
- Input Noise Current 11 pA/√Hz
- Slew Rate 6200 V/μs
- Power 260 mW
- Typical Supply Current 52 mA
- 14-Lead UQFN Package

### 2 Applications

- Differential ADC Driver
- Single-Ended to Differential Converter
- High-Speed Differential Signaling
- IF/RF and Baseband Gain Blocks
- SAW Filter Buffer/Driver
- Oscilloscope Probes
- Automotive Safety Applications
- Video Over Twisted Pair
- Differential Line Driver

### 4 Typical Application Schematic

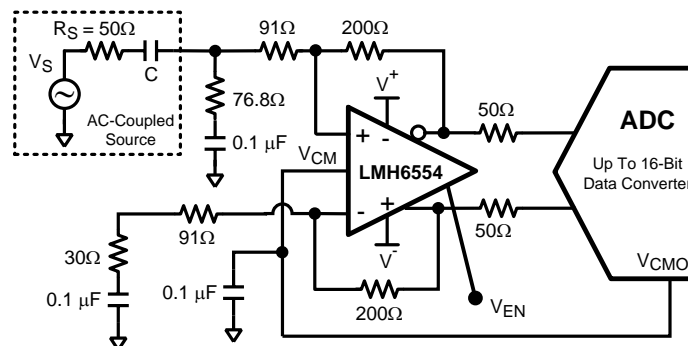

### 3 Description

The LMH6554 device is a high-performance fully differential amplifier designed to provide the exceptional signal fidelity and wide large-signal bandwidth necessary for driving 8- to 16-bit high-speed data acquisition systems. Using TI's proprietary differential current mode input stage architecture, the LMH6554 has unity gain, small-signal bandwidth of 2.8 GHz and allows operation at gains greater than unity without sacrificing response flatness, bandwidth, harmonic distortion, or output noise performance.

The low-impedance differential output of the device is designed to drive ADC inputs and any intermediate filter stage. The LMH6554 delivers 16-bit linearity up to 75 MHz when driving 2-V peak-to-peak into loads as low as 200 Ω.

The LMH6554 is fabricated in TI's advanced complementary BiCMOS process and is available in a space-saving 14-lead UQFN package for higher performance.

#### Device Information<sup>(1)</sup>

PART NUMBER	PACKAGE	BODY SIZE (NOM)
LMH6554	UQFN (14)	2.50 mm × 2.50 mm

(1) For all available packages, see the orderable addendum at the end of the data sheet.



## Table of Contents

<b>1 Features</b> .....	<b>1</b>	<b>9 Application and Implementation</b> .....	<b>13</b>
<b>2 Applications</b> .....	<b>1</b>	9.1 Application Information.....	13
<b>3 Description</b> .....	<b>1</b>	9.2 Typical Applications .....	13
<b>4 Typical Application Schematic</b> .....	<b>1</b>	<b>10 Power Supply Recommendations</b> .....	<b>20</b>
<b>5 Revision History</b> .....	<b>2</b>	10.1 Power Supply Bypassing .....	20
<b>6 Pin Configuration and Functions</b> .....	<b>3</b>	<b>11 Layout</b> .....	<b>21</b>
<b>7 Specifications</b> .....	<b>4</b>	11.1 Layout Guidelines .....	21
7.1 Absolute Maximum Ratings .....	4	11.2 Layout Example .....	21
7.2 ESD Ratings.....	4	11.3 Power Dissipation .....	22
7.3 Recommended Operating Conditions .....	4	11.4 ESD Protection.....	22
7.4 Thermal Information .....	4	<b>12 Device and Documentation Support</b> .....	<b>23</b>
7.5 Electrical Characteristics: +5 V .....	5	12.1 Device Support.....	23
7.6 Typical Performance Characteristics $V_S = \pm 2.5\text{ V}$ ....	7	12.2 Documentation Support .....	23
<b>8 Detailed Description</b> .....	<b>11</b>	12.3 Trademarks .....	23
8.1 Overview .....	11	12.4 Electrostatic Discharge Caution.....	23
8.2 Functional Block Diagram .....	11	12.5 Glossary .....	23
8.3 Feature Description.....	11	<b>13 Mechanical, Packaging, and Orderable Information</b> .....	<b>23</b>
8.4 Device Functional Modes.....	12		

## 5 Revision History

<b>Changes from Revision O (March 2013) to Revision P</b>	<b>Page</b>
<ul style="list-style-type: none"> <li>Added <i>ESD Ratings</i> table, <i>Feature Description</i> section, <i>Device Functional Modes</i>, <i>Application and Implementation</i> section, <i>Power Supply Recommendations</i> section, <i>Layout</i> section, <i>Device and Documentation Support</i> section, and <i>Mechanical, Packaging, and Orderable Information</i> section .....</li> </ul>	1

---

<b>Changes from Revision N (March 2013) to Revision O</b>	<b>Page</b>
<ul style="list-style-type: none"> <li>Changed layout of National Data Sheet to TI format .....</li> </ul>	23

## 6 Pin Configuration and Functions

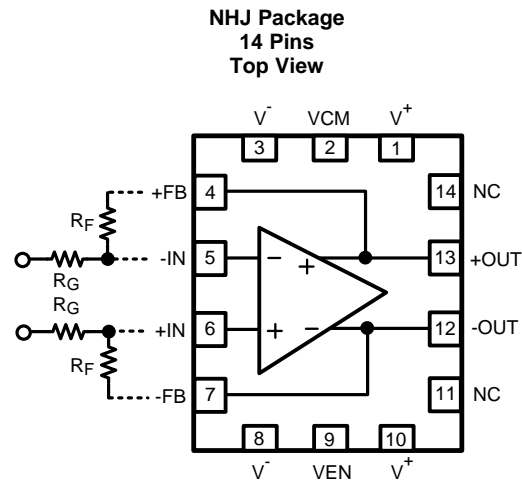

### Pin Functions

PIN		I/O	DESCRIPTION
NAME	NO.		
-FB	7	O	Feedback from -OUT
+FB	4	O	Feedback from +OUT
+IN	6	I	Positive Input
-IN	5	I	Negative Input
NC	11	—	No Connection
NC	14	—	No Connection
-OUT	12	O	Negative Output
+OUT	13	O	Positive Output
VCM	2	I	Output Common Mode Voltage
VEN	9	I	Enable
V-	3	P	Negative Supply
V-	8	P	Negative Supply
V+	1	P	Positive Supply
V+	10	P	Positive Supply

## 7 Specifications

### 7.1 Absolute Maximum Ratings <sup>(1)(2)(3)</sup>

	MIN	MAX	UNIT
Supply Voltage ( $V_S = V^+ - V^-$ )		5.5	V
Common Mode Input Voltage	$V^-$	$V^+$	V
Maximum Operating Junction Temperature		150	°C
Maximum Input Current		30	mA
Maximum Output Current (pins 12, 13)		<sup>(4)</sup>	mA
Soldering Information		260	°C
Infrared or Convection (30 sec)			
Storage Temperature, $T_{stg}$	-65	150	°C

- (1) *Absolute Maximum Ratings* indicate limits beyond which damage to the device may occur. *Recommended Operating Conditions* indicate conditions for which the device is intended to be functional, but specific performance is not ensured. For ensured specifications, see the *Electrical Characteristics: +5 V* tables.
- (2) If Military/Aerospace specified devices are required, please contact the Texas Instruments Sales Office/ Distributors for availability and specifications.
- (3) For soldering specifications, see [SNOA549](#).
- (4) The maximum output current ( $I_{OUT}$ ) is determined by device power dissipation limitations. See *Power Dissipation* for more details.

### 7.2 ESD Ratings

		VALUE	UNIT
$V_{(ESD)}$ Electrostatic discharge	Human-body model (HBM), per ANSI/ESDA/JEDEC JS-001 <sup>(1)</sup>	±2000	V
	Charged-device model (CDM), per JEDEC specification JESD22-C101 <sup>(2)</sup>	±750	
	Machine model (MM)	±250	

- (1) JEDEC document JEP155 states that 500-V HBM allows safe manufacturing with a standard ESD control process.
- (2) JEDEC document JEP157 states that 250-V CDM allows safe manufacturing with a standard ESD control process.

### 7.3 Recommended Operating Conditions

 See <sup>(1)</sup>

	MIN	NOM	MAX	UNIT
Operating Temperature Range	-40		+125	°C
Total Supply Voltage Temperature Range	4.7		5.25	V

- (1) *Absolute Maximum Ratings* indicate limits beyond which damage to the device may occur. *Recommended Operating Conditions* indicate conditions for which the device is intended to be functional, but specific performance is not ensured. For ensured specifications, see the *Electrical Characteristics: +5 V* tables.

### 7.4 Thermal Information

THERMAL METRIC <sup>(1)</sup>	LMH6554	UNIT
	NHJ	
	14 PINS	
$R_{\theta JA}$ Junction-to-ambient thermal resistance	60	°C/W

- (1) For more information about traditional and new thermal metrics, see the *IC Package Thermal Metrics* application report, [SPRA953](#).

## 7.5 Electrical Characteristics: +5 V

Unless otherwise specified, all limits are ensured for  $T_A = +25^\circ\text{C}$ ,  $A_V = +2$ ,  $V^+ = +2.5\text{ V}$ ,  $V^- = -2.5\text{ V}$ ,  $R_L = 200\ \Omega$ ,  $V_{CM} = (V^+ + V^-)/2$ ,  $R_F = 200\ \Omega$ , for single-ended in, differential out. <sup>(1)</sup>

PARAMETER		TEST CONDITIONS	MIN <sup>(2)</sup>	TYP <sup>(3)</sup>	MAX <sup>(2)</sup>	UNIT
<b>AC PERFORMANCE (DIFFERENTIAL)</b>						
SSBW	Small Signal -3 dB Bandwidth <sup>(2)</sup>	$A_V = 1$ , $V_{OUT} = 0.2 V_{PP}$		2800		MHz
		$A_V = 2$ , $V_{OUT} = 0.2 V_{PP}$		2500		
		$A_V = 4$ , $V_{OUT} = 0.2 V_{PP}$		1600		
LSBW	Large Signal Bandwidth	$A_V = 1$ , $V_{OUT} = 2 V_{PP}$		1800		MHz
		$A_V = 2$ , $V_{OUT} = 2 V_{PP}$		1500		
		$A_V = 2$ , $V_{OUT} = 1.5 V_{PP}$		1900		
0.1 dBBW	0.1 dB Bandwidth	$A_V = 2$ , $V_{OUT} = 0.2 V_{PP}$ , $R_F = 250\ \Omega$		830		MHz
SR	Slew Rate	4V Step		6200		V/ $\mu\text{s}$
$t_r/t_f$	Rise/Fall Time	2V Step, 10–90%		290		ps
		0.4V Step, 10–90%		150		
$T_{s,0.1}$	0.1% Settling Time	2V Step, $R_L = 200\ \Omega$		4		ns
	Overdrive Recovery Time	$V_{IN} = 2\text{ V}$ , $A_V = 5\text{ V/V}$		6		ns
<b>DISTORTION AND NOISE RESPONSE</b>						
HD2	2 <sup>nd</sup> Harmonic Distortion	$V_{OUT} = 2 V_{PP}$ , $f = 20\text{ MHz}$		-102		dBc
		$V_{OUT} = 2 V_{PP}$ , $f = 75\text{ MHz}$		-96		
		$V_{OUT} = 2 V_{PP}$ , $f = 125\text{ MHz}$		-87		
		$V_{OUT} = 2 V_{PP}$ , $f = 250\text{ MHz}$		-79		
		$V_{OUT} = 1.5 V_{PP}$ , $f = 250\text{ MHz}$		-81		
HD3	3 <sup>rd</sup> Harmonic Distortion	$V_{OUT} = 2 V_{PP}$ , $f = 20\text{ MHz}$		-110		dBc
		$V_{OUT} = 2 V_{PP}$ , $f = 75\text{ MHz}$		-97		
		$V_{OUT} = 2 V_{PP}$ , $f = 125\text{ MHz}$		-87		
		$V_{OUT} = 2 V_{PP}$ , $f = 250\text{ MHz}$		-70		
		$V_{OUT} = 1.5 V_{PP}$ , $f = 250\text{ MHz}$		-75		
OIP3	Output 3rd-Order Intercept	$f = 150\text{ MHz}$ , $V_{OUT} = 2V_{PP}$ Composite		46.5		dBm
IMD3	Two-Tone Intermodulation	$f = 150\text{ MHz}$ , $V_{OUT} = 2V_{PP}$ Composite		-97		dBc
$e_n$	Input Voltage Noise Density	$f = 10\text{ MHz}$		0.9		nV/ $\sqrt{\text{Hz}}$
$i_{n+}$	Input Noise Current	$f = 10\text{ MHz}$		11		pA/ $\sqrt{\text{Hz}}$
$i_{n-}$	Input Noise Current	$f = 10\text{ MHz}$		11		pA/ $\sqrt{\text{Hz}}$
NF	Noise Figure <sup>(4)</sup>	50 $\Omega$ System, $A_V = 7.3$ , 100 MHz		7.7		dB
<b>INPUT CHARACTERISTICS</b>						
$I_{BI+} / I_{BI-}$			-75	-29	20	$\mu\text{A}$
TCIbi	Input Bias Current Temperature Drift			8		$\mu\text{A}/^\circ\text{C}$
$I_{BID}$	Input Bias Current <sup>(5)</sup>	$V_{CM} = 0\text{ V}$ , $V_{ID} = 0\text{ V}$ , $I_{BOFFSET} = (I_{BI-} - I_{BI+})/2$	-10	1	10	$\mu\text{A}$
TCIbo	Input Bias Current Diff Offset Temperature Drift <sup>(3)</sup>			0.006		$\mu\text{A}/^\circ\text{C}$
CMRR	Common Mode Rejection Ratio	DC, $V_{CM} = 0\text{ V}$ , $V_{ID} = 0\text{ V}$		83		dB

- (1) Electrical Table values apply only for factory testing conditions at the temperature indicated. Factory testing conditions result in very limited self-heating of the device such that  $T_J = T_A$ . No specification of parametric performance is indicated in the electrical tables under conditions of internal self-heating where  $T_J > T_A$ . See [Thermal Information](#) for information on temperature de-rating of this device." Min/Max ratings are based on product characterization and simulation. Individual parameters are tested as noted.
- (2) Limits are 100% production tested at 25°C. Limits over the operating temperature range are ensured through correlation using Statistical Quality Control (SQC) methods.
- (3) Typical values represent the most likely parametric norm as determined at the time of characterization. Actual typical values may vary over time and will also depend on the application and configuration. The typical values are not tested and are not ensured on shipped production material.
- (4) For test schematic, refer to [Figure 34](#).
- (5)  $I_{BI}$  is referred to a differential output offset voltage by the following relationship:  $V_{OD(OFFSET)} = I_{BI} \cdot 2R_F$ .

**Electrical Characteristics: +5 V (continued)**

Unless otherwise specified, all limits are ensured for  $T_A = +25^\circ\text{C}$ ,  $A_V = +2$ ,  $V^+ = +2.5\text{ V}$ ,  $V^- = -2.5\text{ V}$ ,  $R_L = 200\ \Omega$ ,  $V_{CM} = (V^+ + V^-)/2$ ,  $R_F = 200\ \Omega$ , for single-ended in, differential out.<sup>(1)</sup>

PARAMETER		TEST CONDITIONS	MIN <sup>(2)</sup>	TYP <sup>(3)</sup>	MAX <sup>(2)</sup>	UNIT	
$R_{IN}$	Differential Input Resistance	Differential		19		$\Omega$	
$C_{IN}$	Differential Input Capacitance	Differential		1		pF	
CMVR	Input Common Mode Voltage Range	CMRR > 32 dB	$\pm 1.25$	$\pm 1.3$		V	
<b>OUTPUT PERFORMANCE</b>							
	Output Voltage Swing <sup>(3)</sup>	Single-Ended Output	$\pm 1.35$	$\pm 1.42$		V	
$I_{OUT}$	Output Current <sup>(3)</sup>	$V_{OUT} = 0\text{ V}$	$\pm 120$	$\pm 150$		mA	
$I_{SC}$	Short Circuit Current	One Output Shorted to Ground $V_{IN} = 2\text{ V}$ Single-Ended <sup>(6)</sup>		150		mA	
	Output Balance Error	$\Delta V_{OUT}$ Common Mode / $\Delta V_{OUT}$ Differential, $\Delta V_{OD} = 1\text{ V}$ , $f < 1\text{ Mhz}$		-64		dB	
<b>OUTPUT COMMON MODE CONTROL CIRCUIT</b>							
	Common Mode Small Signal Bandwidth	$V_{IN^+} = V_{IN^-} = 0\text{ V}$		500		MHz	
	Slew Rate	$V_{IN^+} = V_{IN^-} = 0\text{ V}$		200		V/ $\mu\text{s}$	
$V_{OSCM}$	Input Offset Voltage	Common Mode, $V_{ID} = 0$ , $V_{CM} = 0\text{ V}$	-16	-6.5	4	mV	
$I_{OSCM}$	Input Offset Current	<sup>(7)</sup>		6	18	$\mu\text{A}$	
	Voltage Range		$\pm 1.18$	$\pm 1.25$		V	
	CMRR	Measure $V_{OD}$ , $V_{ID} = 0\text{ V}$		82		dB	
	Input Resistance			180		k $\Omega$	
	Gain	$\Delta V_{OCM} / \Delta V_{CM}$	0.99	0.995	1.0	V/V	
<b>MISCELLANEOUS PERFORMANCE</b>							
$Z_T$	Open Loop Transimpedance Gain	Differential		180		k $\Omega$	
PSRR	Power Supply Rejection Ratio	DC, $\Delta V^+ = \Delta V^- = 1\text{ V}$	74	95		dB	
$I_S$	Supply Current <sup>(3)</sup>	$R_L = \infty$		46	52	57	mA
			At extreme temperatures			60	
	Enable Voltage Threshold	Single 5V Supply <sup>(8)</sup>		2.5		V	
	Disable Voltage Threshold	Single 5V Supply <sup>(8)</sup>		2.5		V	
	Enable/Disable Time			15		ns	
$I_{SD}$	Supply Current, Disabled	Enable=0, Single 5-V supply		450	510	570	$\mu\text{A}$
			At extreme temperatures			600	

(6) Short circuit current should be limited in duration to no more than 10 seconds. See [Power Dissipation](#) for more details.

(7) Negative input current implies current flowing out of the device.

(8)  $V_{EN}$  threshold is typically  $\pm 0.3\text{ V}$  centered around  $(V^+ + V^-) / 2$  relative to ground.

### 7.6 Typical Performance Characteristics $V_S = \pm 2.5\text{ V}$

( $T_A = 25^\circ\text{C}$ ,  $R_F = 200\ \Omega$ ,  $R_G = 90\ \Omega$ ,  $R_T = 76.8\ \Omega$ ,  $R_L = 200\ \Omega$ ,  $A_V = +2$ , for single ended in, differential out, unless specified).

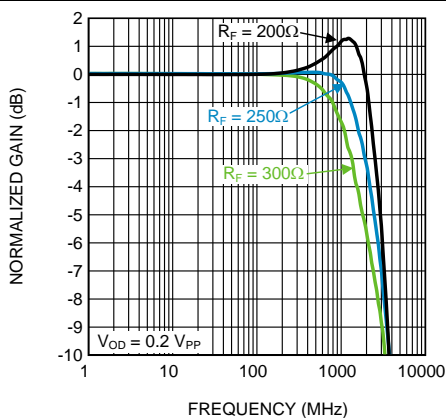

Figure 1. Frequency Response vs  $R_F$

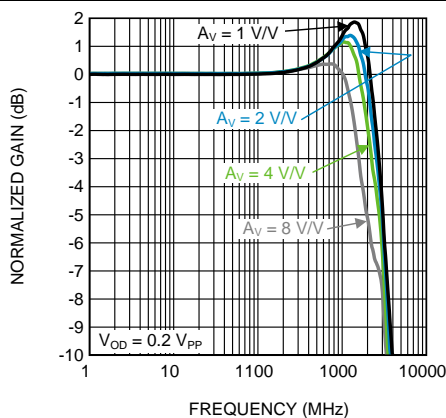

Figure 2. Frequency Response vs Gain

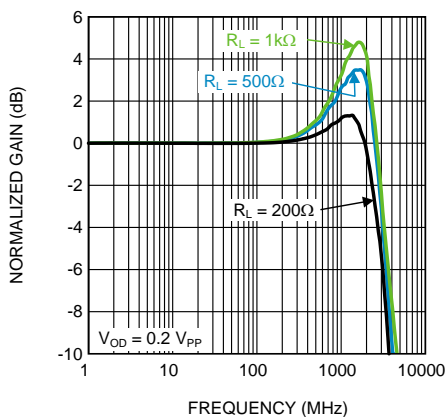

Figure 3. Frequency Response vs  $R_L$

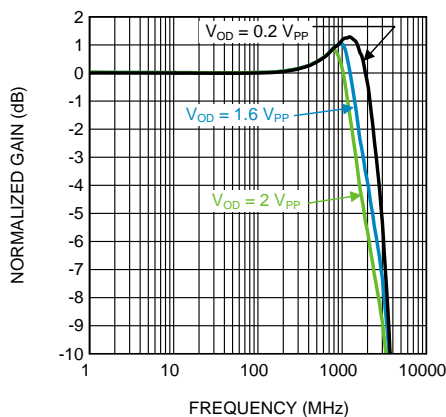

Figure 4. Frequency Response vs Output Voltage ( $V_{OD}$ )

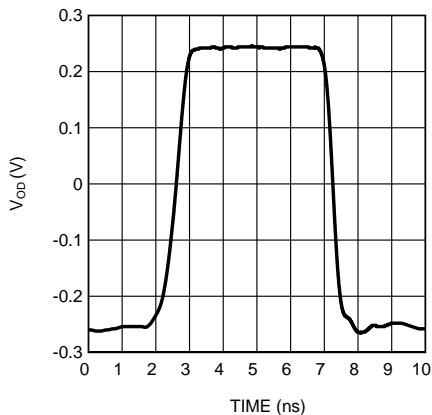

Figure 5.  $0.5\text{ V}_{PP}$  Pulse Response Single-Ended Input

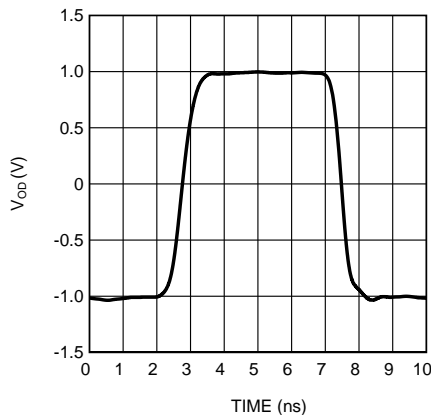
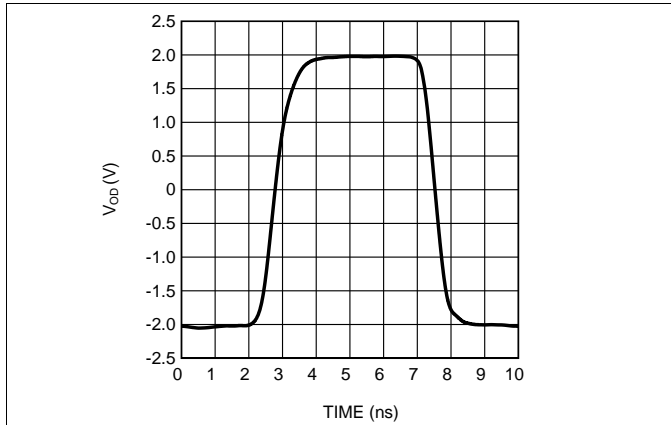

Figure 6.  $2\text{ V}_{PP}$  Pulse Response Single-Ended Input

**Typical Performance Characteristics  $V_S = \pm 2.5\text{ V}$  (continued)**

( $T_A = 25^\circ\text{C}$ ,  $R_F = 200\ \Omega$ ,  $R_G = 90\ \Omega$ ,  $R_T = 76.8\ \Omega$ ,  $R_L = 200\ \Omega$ ,  $A_V = +2$ , for single ended in, differential out, unless specified).



**Figure 7. 4 V<sub>PP</sub> Pulse Response Single-Ended Input**

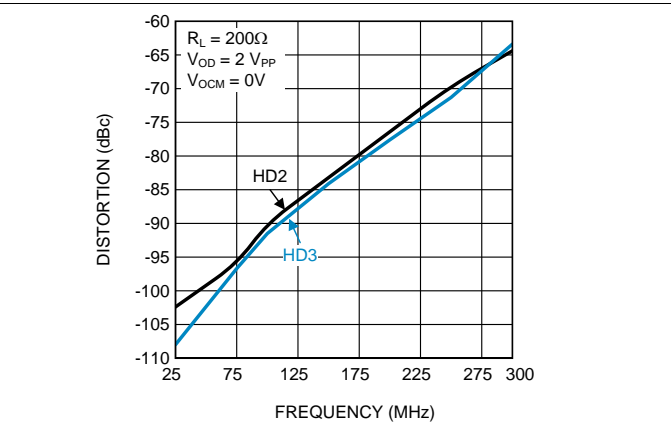

**Figure 8. Distortion vs Frequency Single-Ended Input**

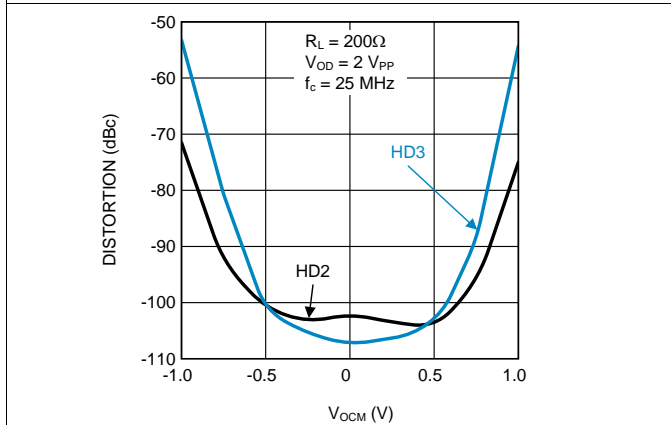

**Figure 9. Distortion vs Output Common Mode Voltage**

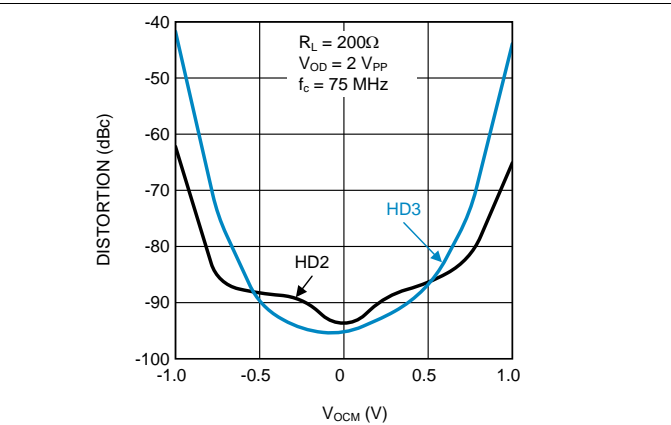

**Figure 10. Distortion vs Output Common Mode Voltage**

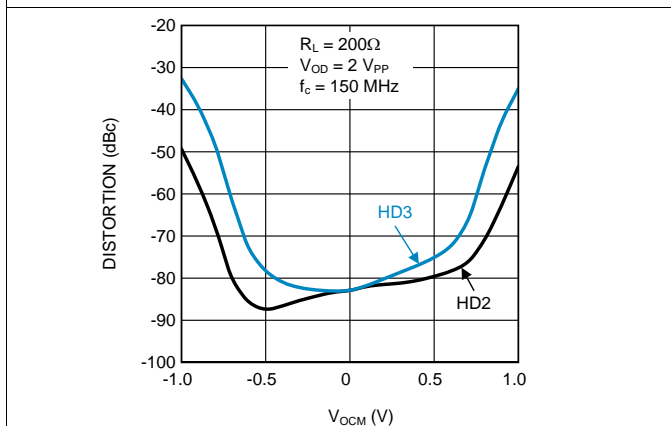

**Figure 11. Distortion vs Output Common Mode Voltage**

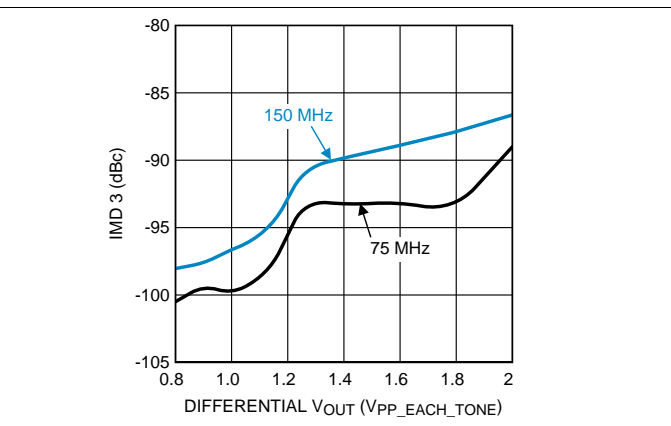

**Figure 12. 3rd Order Intermodulation Products vs V<sub>OUT</sub>**

Typical Performance Characteristics  $V_S = \pm 2.5\text{ V}$  (continued)

( $T_A = 25^\circ\text{C}$ ,  $R_F = 200\ \Omega$ ,  $R_G = 90\ \Omega$ ,  $R_T = 76.8\ \Omega$ ,  $R_L = 200\ \Omega$ ,  $A_V = +2$ , for single ended in, differential out, unless specified).

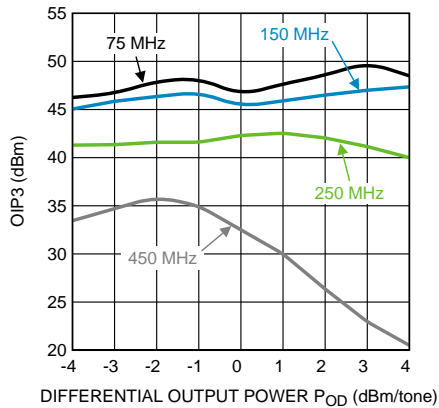

Figure 13. OIP3 vs Output Power  $P_{OUT}$

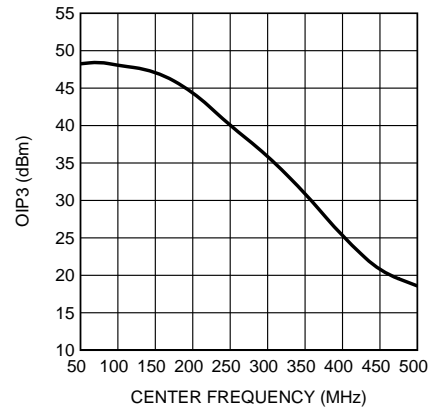

Figure 14. OIP3 vs Center Frequency

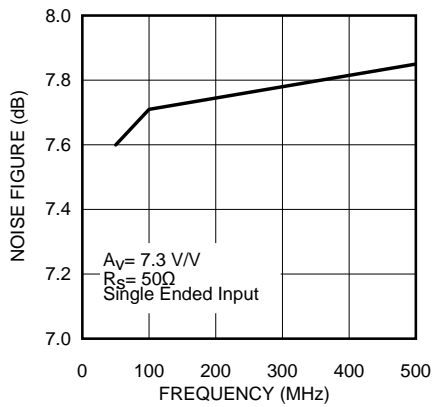

Figure 15. Noise Figure vs Frequency

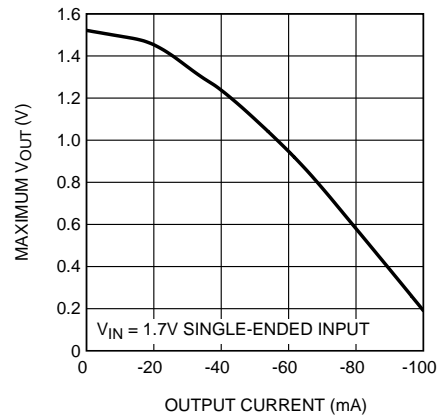

Figure 16. Maximum  $V_{OUT}$  vs  $I_{OUT}$

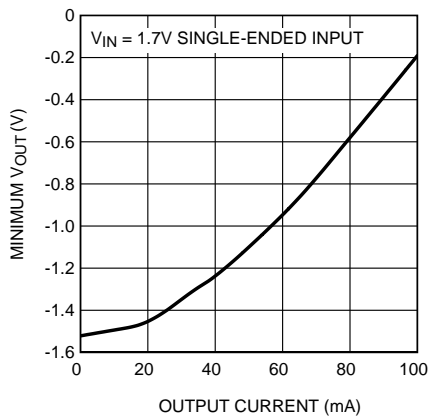

Figure 17. Minimum  $V_{OUT}$  vs  $I_{OUT}$

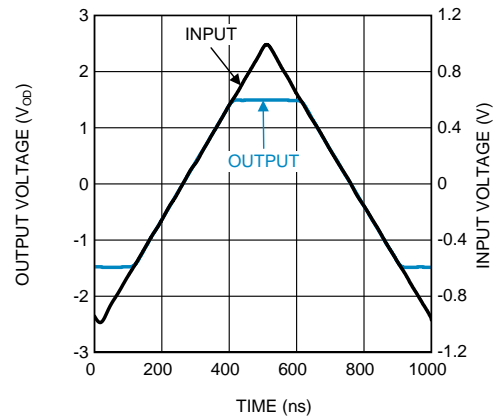

Figure 18. Overdrive Recovery

Typical Performance Characteristics  $V_S = \pm 2.5\text{ V}$  (continued)

( $T_A = 25^\circ\text{C}$ ,  $R_F = 200\ \Omega$ ,  $R_G = 90\ \Omega$ ,  $R_T = 76.8\ \Omega$ ,  $R_L = 200\ \Omega$ ,  $A_V = +2$ , for single ended in, differential out, unless specified).

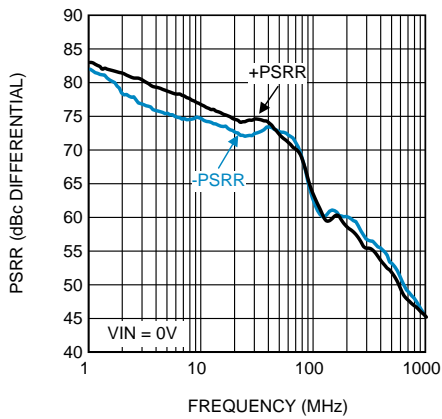

Figure 19. PSRR

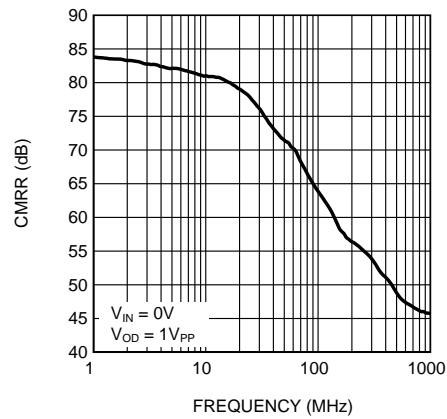

Figure 20. CMRR

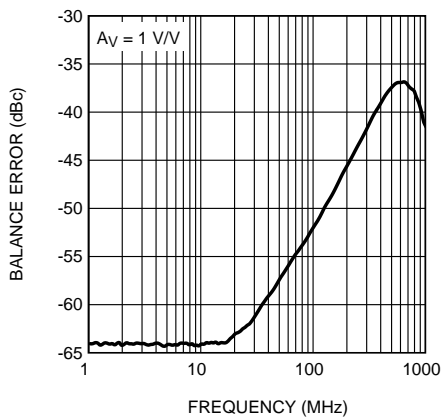

Figure 21. Balance Error

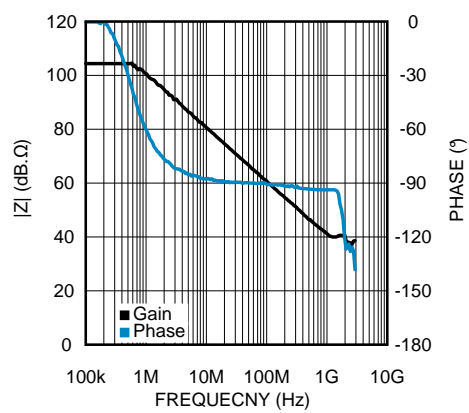

Figure 22. Open Loop Transimpedance

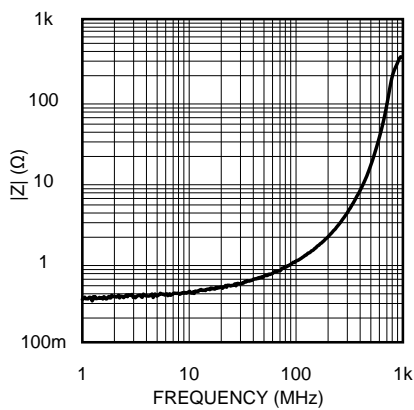

Figure 23. Closed-Loop Output Impedance

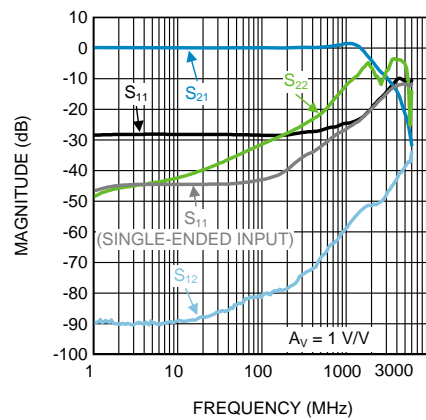

Figure 24. Differential S-Parameter Magnitude vs Frequency

## 8 Detailed Description

### 8.1 Overview

The LMH6554 is a fully differential, current feedback amplifier with integrated output common mode control, designed to provide low distortion amplification to wide bandwidth differential signals. The common mode feedback circuit sets the output common mode voltage independent of the input common mode, as well as forcing the  $V+$  and  $V-$  outputs to be equal in magnitude and opposite in phase, even when only one of the inputs is driven as in single to differential conversion.

The proprietary current feedback architecture of the LMH6554 offers gain and bandwidth independence with exceptional gain flatness and noise performance, even at high values of gain, simply with the appropriate choice of  $RF1$  and  $RF2$ . Generally  $RF1$  is set equal to  $RF2$ , and  $RG1$  equal to  $RG2$ , so that the gain is set by the ratio  $RF/RG$ . Matching of these resistors greatly affects CMRR, DC offset error, and output balance.

### 8.2 Functional Block Diagram

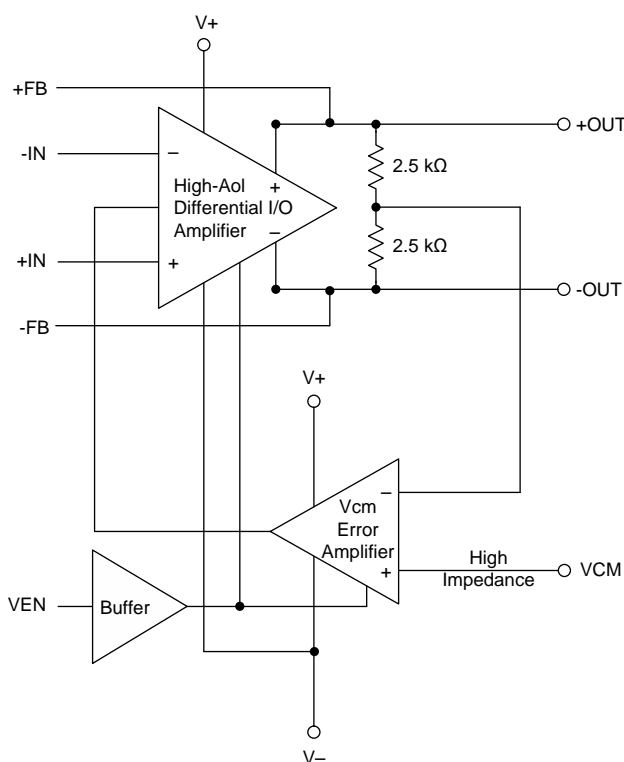

### 8.3 Feature Description

The proprietary current feedback architecture of the LMH6554 offers gain and bandwidth independence with exceptional gain flatness and noise performance, even at high values of gain, simply with the appropriate choice of  $RF1$  and  $RF2$ . Generally  $RF1$  is set equal to  $RF2$ , and  $RG1$  equal to  $RG2$ , so that the gain is set by the ratio  $RF/RG$ . Matching of these resistors greatly affects CMRR, DC offset error, and output balance. A maximum of 0.1% tolerance resistors are recommended for optimal performance, and the amplifier is internally compensated to operate with optimum gain flatness with  $RF$  value of  $200\ \Omega$  depending on PCB layout, and load resistance. The output common mode voltage is set by the VCM pin with a fixed gain of  $1\ V/V$ . This pin should be driven by a low impedance reference and should be bypassed to ground with a  $0.1\ \mu\text{F}$  ceramic capacitor. Any unwanted signal coupling into the VCM pin will be passed along to the outputs, reducing the performance of the amplifier. The LMH6554 can be configured to operate on a single 5V supply connected to  $V+$  with  $V-$  grounded or configured for a split supply operation with  $V+ = +2.5\ V$  and  $V- = -2.5\ V$ . Operation on a single 5-V supply, depending on gain, is limited by the input common mode range; therefore, AC coupling may be required.

## 8.4 Device Functional Modes

This wideband FDA requires external resistors for correct signal-path operation. When configured for the desired input impedance and gain setting with these external resistors, the amplifier can be either on with the PD pin asserted to a voltage greater than  $V_{S-} + 1.7$  V, or turned off by asserting PD low. Disabling the amplifier shuts off the quiescent current and stops correct amplifier operation. The signal path is still present for the source signal through the external resistors. The Vocm control pin sets the output average voltage. Left open, Vocm defaults to an internal midsupply value. Driving this high-impedance input with a voltage reference within its valid range sets a target for the internal Vcm error amplifier.

## 9 Application and Implementation

### NOTE

Information in the following applications sections is not part of the TI component specification, and TI does not warrant its accuracy or completeness. TI's customers are responsible for determining suitability of components for their purposes. Customers should validate and test their design implementation to confirm system functionality.

### 9.1 Application Information

The LMH6554 is a fully differential, current feedback amplifier with integrated output common mode control, designed to provide low distortion amplification to wide bandwidth differential signals. The common mode feedback circuit sets the output common mode voltage independent of the input common mode, as well as forcing the  $V^+$  and  $V^-$  outputs to be equal in magnitude and opposite in phase, even when only one of the inputs is driven as in single to differential conversion.

The proprietary current feedback architecture of the LMH6554 offers gain and bandwidth independence with exceptional gain flatness and noise performance, even at high values of gain, simply with the appropriate choice of  $R_{F1}$  and  $R_{F2}$ . Generally  $R_{F1}$  is set equal to  $R_{F2}$ , and  $R_{G1}$  equal to  $R_{G2}$ , so that the gain is set by the ratio  $R_F/R_G$ . Matching of these resistors greatly affects CMRR, DC offset error, and output balance. A maximum of 0.1% tolerance resistors are recommended for optimal performance, and the amplifier is internally compensated to operate with optimum gain flatness with  $R_F$  value of 200  $\Omega$  depending on PCB layout, and load resistance.

The output common mode voltage is set by the  $V_{CM}$  pin with a fixed gain of 1 V/V. This pin should be driven by a low impedance reference and should be bypassed to ground with a 0.1- $\mu$ F ceramic capacitor. Any unwanted signal coupling into the  $V_{CM}$  pin will be passed along to the outputs, reducing the performance of the amplifier.

The LMH6554 can be configured to operate on a single 5-V supply connected to  $V+$  with  $V-$  grounded or configured for a split supply operation with  $V^+ = +2.5$  V and  $V^- = -2.5$  V. Operation on a single 5-V supply, depending on gain, is limited by the input common mode range; therefore, AC coupling may be required. Split supplies will allow much less restricted AC and DC coupled operation with optimum distortion performance.

### 9.2 Typical Applications

#### 9.2.1 Single-Ended Input to Differential Output Operation

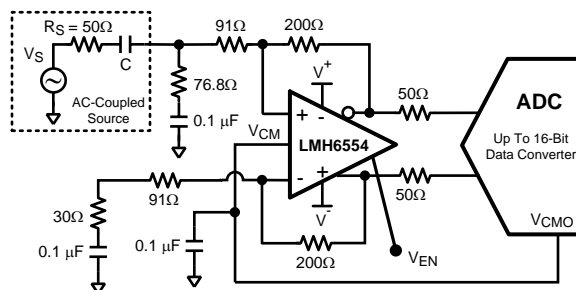

Figure 25. Single-Ended Input to Differential Output Schematic

##### 9.2.1.1 Design Requirements

One typical application for the LMH6554 is to drive an ADC as shown in Figure 25. The following design is a single-ended to differential circuit with an input impedance of 50  $\Omega$  and an output impedance of 100  $\Omega$ . The  $V_{CM}$  voltage of the amplifier needs to be set to the same voltage as the ADC reference voltage, which is typically 1.2 V. Figure 27 shows the design equations required to set the external resistor values. This design also requires a gain of 2 and -96 dBc THD at 75 MHz.

## Typical Applications (continued)

### 9.2.1.2 Detailed Design Procedure

To match the input impedance of the circuit in [Figure 27](#) to a specified source resistance,  $R_S$ , requires that  $R_T \parallel R_{IN} = R_S$ . The equations governing  $R_{IN}$  and  $A_V$  for single-to-differential operation are also provided in [Figure 27](#). These equations, along with the source matching condition, must be solved iteratively to achieve the desired gain with the proper input termination. Component values for several common gain configuration in a 50  $\Omega$  environment are given in [Table 1](#).

#### 9.2.1.2.1 Enable / Disable Operation

The LMH6554 is equipped with an enable pin ( $V_{EN}$ ) to reduce power consumption when not in use. The  $V_{EN}$  pin, when not driven, floats high (on). When the  $V_{EN}$  pin is pulled low, the amplifier is disabled and the amplifier output stage goes into a high impedance state so the feedback and gain set resistors determine the output impedance of the circuit. For this reason input to output isolation will be poor in the disabled state and the part is not recommended in multiplexed applications where outputs are all tied together.

With a 5V difference between  $V^+$  and  $V^-$ , the  $V_{EN}$  threshold is  $\frac{1}{2}$  way between the supplies (e.g. 2.5V with 5V single supply) as shown in [Figure 26](#).  $R_2$  ensures active (enable) mode with  $V_{EN}$  floating, and  $R_1$  provides input current limiting.  $V_{EN}$  also has ESD diodes to either supply.

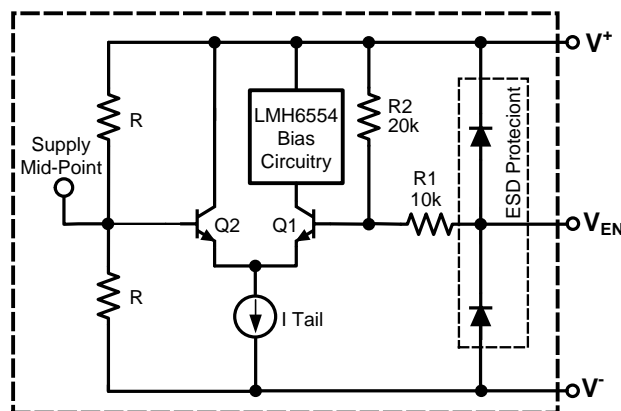
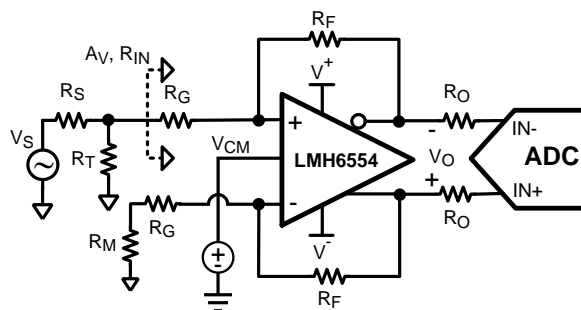

**Figure 26. Enable Block Diagram**

#### 9.2.1.2.2 Single-Ended Input to Differential Output Operation

In many applications, it is required to drive a differential input ADC from a single ended source. Traditionally, transformers have been used to provide single to differential conversion, but these are inherently bandpass by nature and cannot be used for DC coupled applications. The LMH6554 provides excellent performance as a single-ended input to differential output converter down to DC. [Figure 27](#) shows a typical application circuit where an LMH6554 is used to produce a balanced differential output signal from a single ended source.

Typical Applications (continued)



$$A_V = \left( \frac{2(1 - \beta_1)}{\beta_1 + \beta_2} \right) \quad \beta_1 = \left( \frac{R_G}{R_G + R_F} \right)$$

$$R_{IN} = \left( \frac{2R_G + R_M(1 - \beta_2)}{1 + \beta_2} \right) \quad \beta_2 = \left( \frac{R_G + R_M}{R_G + R_F + R_M} \right)$$

$R_S = R_T \parallel R_{IN}$   
 $R_M = R_T \parallel R_S$

Figure 27. Single-Ended Input with Differential Output

When using the LMH6554 in single-to-differential mode, the complimentary output is forced to a phase inverted replica of the driven output by the common mode feedback circuit as opposed to being driven by its own complimentary input. Consequently, as the driven input changes, the common mode feedback action results in a varying common mode voltage at the amplifier's inputs, proportional to the driving signal. Due to the non-ideal common mode rejection of the amplifier's input stage, a small common mode signal appears at the outputs which is superimposed on the differential output signal. The ratio of the change in output common mode voltage to output differential voltage is commonly referred to as output balance error. The output balance error response of the LMH6554 over frequency is shown in the *Typical Performance Characteristics*  $V_S = \pm 2.5 V$ .

To match the input impedance of the circuit in Figure 27 to a specified source resistance,  $R_S$ , requires that  $R_T \parallel R_{IN} = R_S$ . The equations governing  $R_{IN}$  and  $A_V$  for single-to-differential operation are also provide in Figure 27. These equations, along with the source matching condition, must be solved iteratively to achieve the desired gain with the proper input termination. Component values for several common gain configuration in a 50Ω environment are given in Table 1.

Table 1. Gain Component Values for 50 Ω System

GAIN	$R_F$	$R_G$	$R_T$	$R_M$
0dB	200Ω	191Ω	62Ω	27.7Ω
6dB	200Ω	91Ω	76.8Ω	30.3Ω
12dB	200Ω	35.7Ω	147Ω	37.3Ω

9.2.1.2.3 Driving Capacitive Loads

As noted previously, capacitive loads should be isolated from the amplifier output with small valued resistors. This is particularly the case when the load has a resistive component that is 500 Ω or higher. A typical ADC has capacitive components of around 10 pF and the resistive component could be 1000 Ω or higher. If driving a transmission line, such as 50-Ω coaxial or 100-Ω twisted pair, using matching resistors will be sufficient to isolate any subsequent capacitance. For other applications, see Figure 29 in *Typical Performance Characteristics*  $V_S = \pm 2.5 V$ .

9.2.1.3 Application Curves

Many application circuits will have capacitive loading. As shown in Figure 28, amplifier bandwidth is reduced with increasing capacitive load, so parasitic capacitance should be strictly limited.

In order to ensure stability resistance should be added between the capacitive load and the amplifier output pins. The value of the resistor is dependent on the amount of capacitive load as shown in Figure 29. This resistive value is a suggestion. System testing will be required to determine the optimal value. Using a smaller resistor will retain more system bandwidth at the expense of overshoot and ringing, while larger values of resistance will reduce overshoot but will also reduce system bandwidth.

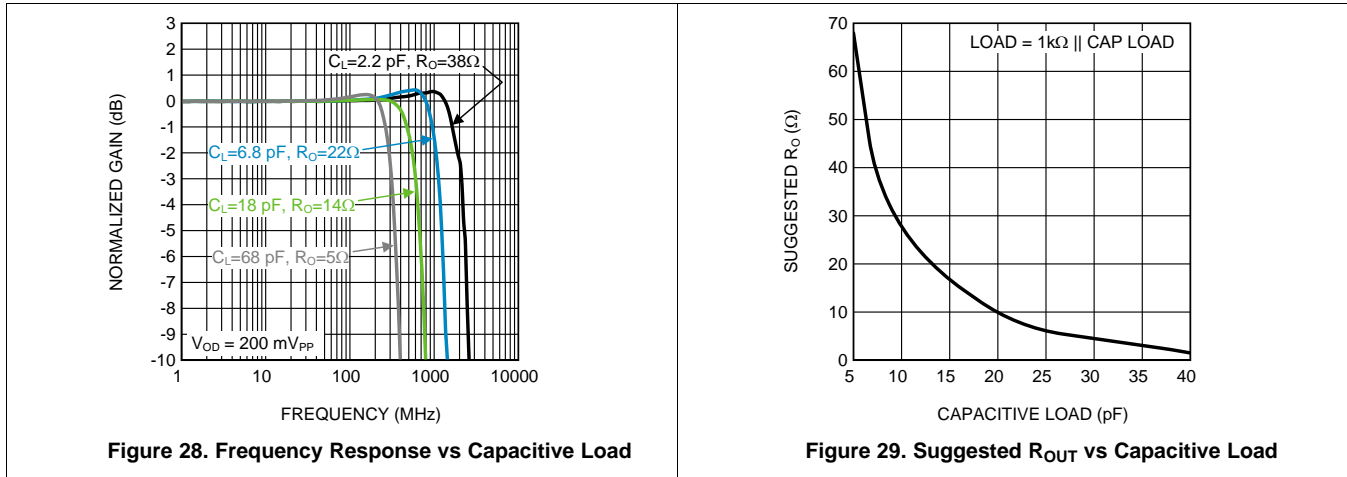

9.2.2 Fully Differential Operation

The LMH6554 will perform best in a fully differential configuration. The circuit shown in Figure 30 is a typical fully differential application circuit as might be used to drive an analog to digital converter (ADC). In this circuit the closed loop gain is  $A_V = V_{OUT} / V_{IN} = R_F / R_G$ , where the feedback is symmetric. The series output resistors,  $R_O$ , are optional and help keep the amplifier stable when presented with a capacitive load. Refer to the *Driving Capacitive Loads* section for details.

Here is the expression for the input impedance,  $R_{IN}$ , as defined in Figure 30:

$$R_{IN} = 2R_G$$

When driven from a differential source, the LMH6554 provides low distortion, excellent balance, and common mode rejection. This is true provided the resistors  $R_F$ ,  $R_G$  and  $R_O$  are well matched and strict symmetry is observed in board layout. With an intrinsic device CMRR of greater than 70 dB, using 0.1% resistors will give a worst case CMRR of around 50 dB for most circuits.

The circuit configuration shown in Figure 30 was used to measure differential S-parameters in a 100Ω environment at a gain of 1 V/V. Refer to Figure 24 in *Typical Performance Characteristics*  $V_S = \pm 2.5 V$  for measurement results.

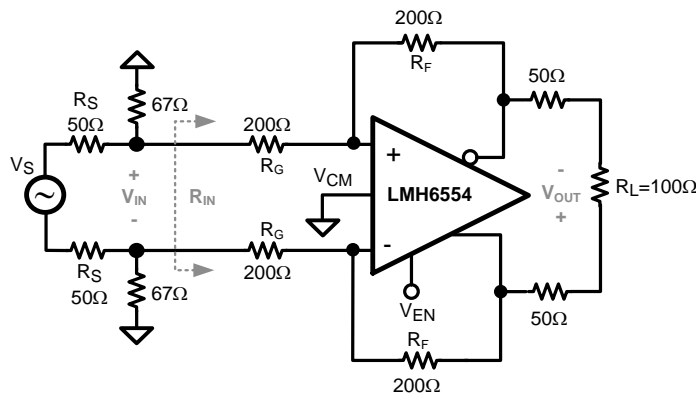
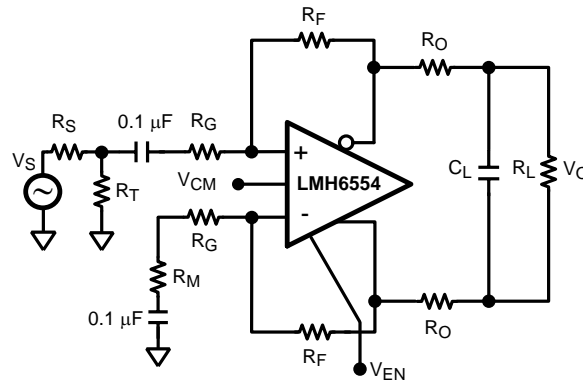

Figure 30. Differential S-Parameter Test Circuit

### 9.2.3 Single Supply Operation

Single 5V supply operation is possible: however, as discussed earlier, AC input coupling is recommended due to input common mode limitations. An example of an AC coupled, single supply, single-to-differential circuit is shown in Figure 31. Note that when AC coupling, both inputs need to be AC coupled irrespective of single-to-differential or differential-differential configuration. For higher supply voltages DC coupling of the inputs may be possible provided that the output common mode DC level is set high enough so that the amplifier's inputs and outputs are within their specified operation ranges.



**Figure 31. AC Coupled for Single Supply Operation**

For optimum performance, split supply operation is recommended using +2.5-V and -2.5-V supplies; however, operation is possible on split supplies as low as +2.35 V and -2.35 V and as high as +2.65 V and -2.65 V. Provided the total supply voltage does not exceed the 4.7-V to 5.3-V operating specification, non-symmetric supply operation is also possible and in some cases advantageous. For example, if a 5-V DC coupled operation is required for low power dissipation but the amplifier input common mode range prevents this operation, it is still possible with split supplies of (V+) and (V-). Where (V+)-(V-) = 5 V and V+ and V- are selected to center the amplifier input common mode range to suit the application.

### 9.2.4 Driving Analog-to-Digital Converters

Analog-to-digital converters present challenging load conditions. They typically have high impedance inputs with large and often variable capacitive components. Figure 32 shows the LMH6554 driving an ultra-high-speed Gigasample ADC the ADC10D1500. The LMH6554 common mode voltage is set by the ADC10D1500. The circuit in Figure 32 has a 2nd order bandpass LC filter across the differential inputs of the ADC10D1500. The ADC10D1500 is a dual channel 10-bit ADC with maximum sampling rate of 3 GSPS when operating in a single channel mode and 1.5 GSPS in dual channel mode.

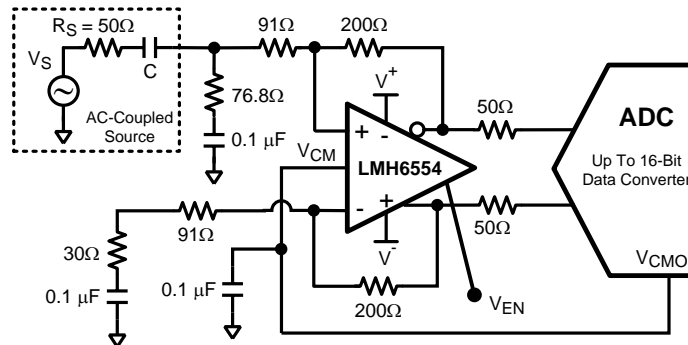

Figure 32. Driving a 10-bit Gigasample ADC

Figure 33 shows the SFDR and SNR performance vs. frequency for the LMH6554 and ADC10D1500 combination circuit with the ADC input signal level at  $-1\text{dBFS}$ . In order to properly match the input impedance seen at the LMH6554 amplifier inputs,  $R_M$  is chosen to match  $Z_S \parallel R_T$  for proper input balance. The amplifier is configured to provide a gain of  $2\text{ V/V}$  in single to differential mode. An external bandpass filter is inserted in series between the input signal source and the amplifier to reduce harmonics and noise from the signal generator.

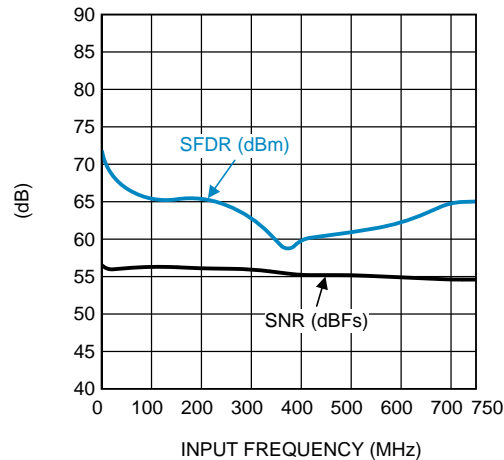

Figure 33. LMH6554 / ADC10D1500 SFDR and SNR Performance vs. Frequency

The amplifier and ADC should be located as close together as possible. Both devices require that the filter components be in close proximity to them. The amplifier needs to have minimal parasitic loading on its outputs and the ADC is sensitive to high frequency noise that may couple in on its inputs. Some high performance ADCs have an input stage that has a bandwidth of several times its sample rate. The sampling process results in all input signals presented to the input stage mixing down into the first Nyquist zone (DC to  $F_s/2$ ).

### 9.2.5 Output Noise Performance and Measurement

Unlike differential amplifiers based on voltage feedback architectures, noise sources internal to the LMH6554 refer to the inputs largely as current sources, hence the low input referred voltage noise and relatively higher input referred current noise. The output noise is therefore more strongly coupled to the value of the feedback resistor and not to the closed loop gain, as would be the case with a voltage feedback differential amplifier. This allows operation of the LMH6554 at much higher gain without incurring a substantial noise performance penalty, simply by choosing a suitable feedback resistor.

Figure 34 shows a circuit configuration used to measure noise figure for the LMH6554 in a 50-Ω system. A feedback resistor value of 200Ω is chosen for the UQFN package to minimize output noise while simultaneously allowing both high gain (7 V/V) and proper 50-Ω input termination. Refer to [Single-Ended Input to Differential Output Operation](#) for the calculation of resistor and gain values.

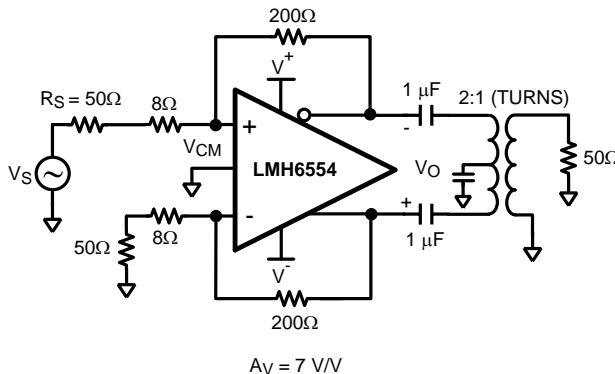

Figure 34. Noise Figure Circuit Configuration

### 9.2.6 Balanced Cable Driver

With up to 5.68 V<sub>PP</sub> differential output voltage swing the LMH6554 can be configured as a cable driver. The LMH6554 is also suitable for driving differential cables from a single ended source as shown in Figure 35.

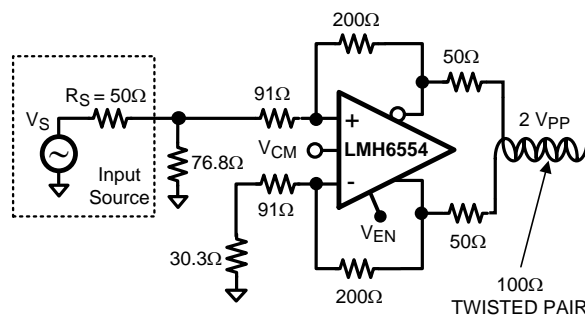

Figure 35. Fully Differential Cable Driver

## 10 Power Supply Recommendations

The LMH6554 can be used with any combination of positive and negative power supplies as long as the combined supply voltage is between 4.7 V and 5.25 V. The LMH6554 will provide best performance when the output voltage is set at the mid supply voltage, and when the total supply voltage is set to 5 V.

Power supply bypassing as shown in [Power Supply Bypassing](#) is important and power supply regulation should be within 5% or better.

### 10.1 Power Supply Bypassing

The LMH6554 requires supply bypassing capacitors as shown in [Figure 36](#) and [Figure 37](#). The 0.01- $\mu\text{F}$  and 0.1- $\mu\text{F}$  capacitors should be leadless SMT ceramic capacitors and should be no more than 3 mm from the supply pins. These capacitors should be star routed with a dedicated ground return plane or trace for best harmonic distortion performance. Thin traces or small vias will reduce the effectiveness of bypass capacitors. Also shown in both figures is a capacitor from the  $V_{\text{CM}}$  and  $V_{\text{EN}}$  pins to ground. These inputs are high impedance and can provide a coupling path into the amplifier for external noise sources, possibly resulting in loss of dynamic range, degraded CMRR, degraded balance and higher distortion.

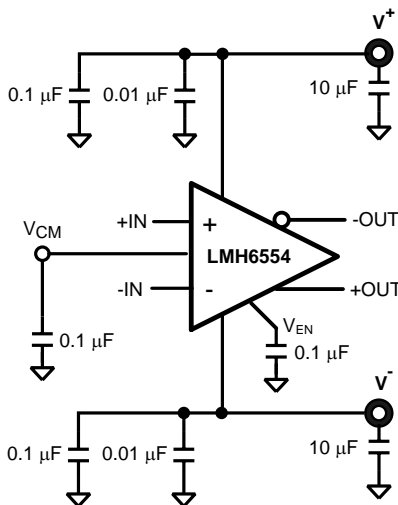

**Figure 36. Split Supply Bypassing Capacitors**

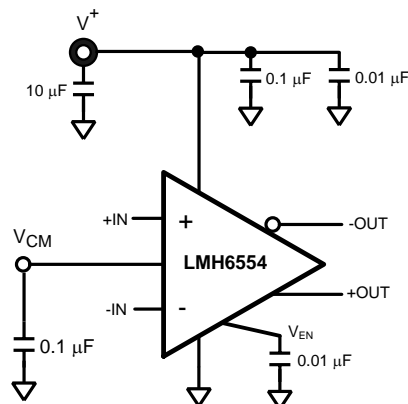

**Figure 37. Single Supply Bypassing Capacitors**

## 11 Layout

### 11.1 Layout Guidelines

The LMH6554 is a high speed, high performance amplifier. In order to get maximum benefit from the differential circuit architecture board layout and component selection is very critical. The circuit board should have a low inductance ground plane and well bypassed broad supply lines. External components should be leadless surface mount types. The feedback network and output matching resistors should be composed of short traces and precision resistors (0.1%). The output matching resistors should be placed within 3 or 4 mm of the amplifier as should the supply bypass capacitors. Refer to [Power Supply Bypassing](#) for recommendations on bypass circuit layout. Evaluation boards are available through the product folder on [ti.com](#).

By design, the LMH6554 is relatively insensitive to parasitic capacitance at its inputs. Nonetheless, ground and power plane metal should be removed from beneath the amplifier and from beneath  $R_F$  and  $R_G$  for best performance at high frequency.

With any differential signal path, symmetry is very important. Even small amounts of asymmetry can contribute to distortion and balance errors.

### 11.2 Layout Example

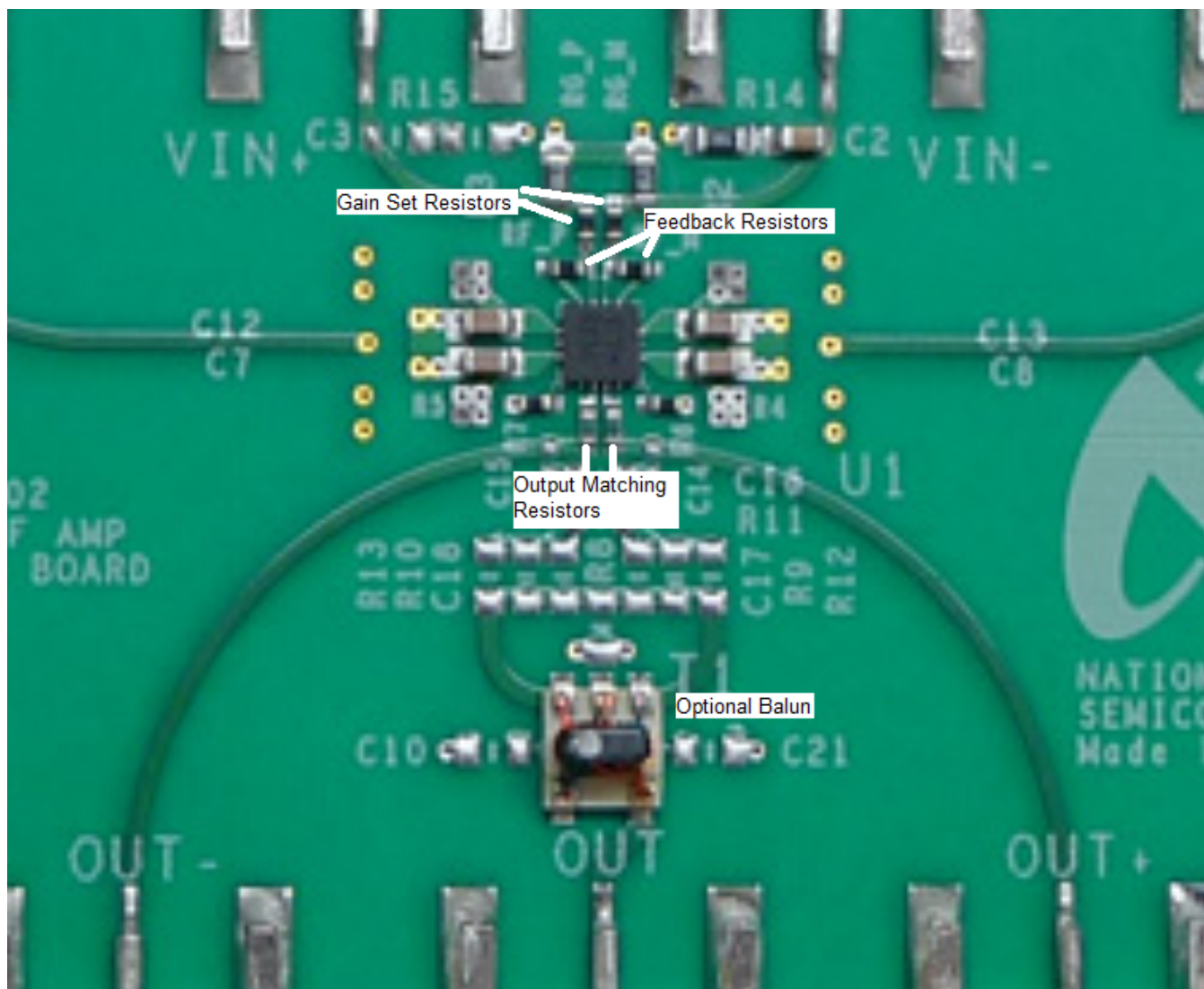

Figure 38. Layout Schematic

### 11.3 Power Dissipation

The LMH6554 is optimized for maximum speed and performance in a small form factor 14 lead UQFN package. To ensure maximum output drive and highest performance, thermal shutdown is not provided. Therefore, it is of utmost importance to make sure that the  $T_{JMAX}$  is never exceeded due to the overall power dissipation.

Follow these steps to determine the maximum power dissipation for the LMH6554:

1. Calculate the quiescent (no-load) power:

$$P_{AMP} = I_{CC} * (V_S)$$

where

- $V_S = V^+ - V^-$ . (Be sure to include any current through the feedback network if  $V_{CM}$  is not mid-rail) (1)

2. Calculate the RMS power dissipated in each of the output stages:

$$P_D (rms) = rms ((V_S - V_{+OUT}) * I_{+OUT}) + rms ((V_S - V_{-OUT}) * I_{-OUT})$$

where

- $V_{OUT}$  and  $I_{OUT}$  are the voltage
- the current measured at the output pins of the differential amplifier as if they were single ended amplifiers
- $V_S$  is the total supply voltage (2)

3. Calculate the total RMS power:

$$P_T = P_{AMP} + P_D (3)$$

The maximum power that the LMH6554 package can dissipate at a given temperature can be derived with the following equation:

$$P_{MAX} = (150^\circ - T_{AMB}) / \theta_{JA}$$

where

- $T_{AMB}$  = Ambient temperature ( $^\circ C$ )
- $\theta_{JA}$  = Thermal resistance, from junction to ambient, for a given package ( $^\circ C/W$ )
- For the 14 lead UQFN package,  $\theta_{JA}$  is  $60^\circ C/W$  (4)

---

#### NOTE

If  $V_{CM}$  is not 0V then there will be quiescent current flowing in the feedback network. This current should be included in the thermal calculations and added into the quiescent power dissipation of the amplifier.

---

### 11.4 ESD Protection

The LMH6554 is protected against electrostatic discharge (ESD) on all pins. The LMH6554 can survive 2000 V Human Body model and 250 V Machine model events. Under normal operation the ESD diodes have no affect on circuit performance. There are occasions, however, when the ESD diodes will be evident. If the LMH6554 is driven by a large signal while the device is powered down the ESD diodes will conduct. The current that flows through the ESD diodes will either exit the chip through the supply pins or will flow through the device, hence it is possible to power up a chip with a large signal applied to the input pins. Using the shutdown mode is one way to conserve power and still prevent unexpected operation.

## 12 Device and Documentation Support

### 12.1 Device Support

#### 12.1.1 Third-Party Products Disclaimer

TI'S PUBLICATION OF INFORMATION REGARDING THIRD-PARTY PRODUCTS OR SERVICES DOES NOT CONSTITUTE AN ENDORSEMENT REGARDING THE SUITABILITY OF SUCH PRODUCTS OR SERVICES OR A WARRANTY, REPRESENTATION OR ENDORSEMENT OF SUCH PRODUCTS OR SERVICES, EITHER ALONE OR IN COMBINATION WITH ANY TI PRODUCT OR SERVICE.

### 12.2 Documentation Support

#### 12.2.1 Related Documentation

See [LMH6554 Product Folder](#) for evaluation board availability and ordering information.

### 12.3 Trademarks

All trademarks are the property of their respective owners.

### 12.4 Electrostatic Discharge Caution



These devices have limited built-in ESD protection. The leads should be shorted together or the device placed in conductive foam during storage or handling to prevent electrostatic damage to the MOS gates.

### 12.5 Glossary

[SLYZ022](#) — *TI Glossary*.

This glossary lists and explains terms, acronyms, and definitions.

## 13 Mechanical, Packaging, and Orderable Information

The following pages include mechanical, packaging, and orderable information. This information is the most current data available for the designated devices. This data is subject to change without notice and revision of this document. For browser-based versions of this data sheet, refer to the left-hand navigation.

**PACKAGING INFORMATION**

Orderable Device	Status (1)	Package Type	Package Drawing	Pins	Package Qty	Eco Plan (2)	Lead/Ball Finish (6)	MSL Peak Temp (3)	Op Temp (°C)	Device Marking (4/5)	Samples
LMH6554LE/NOPB	ACTIVE	UQFN	NHJ	14	1000	Green (RoHS & no Sb/Br)	CU SN	Level-3-260C-168 HR	-40 to 125	AJA	<a href="#">Samples</a>
LMH6554LEE/NOPB	ACTIVE	UQFN	NHJ	14	250	Green (RoHS & no Sb/Br)	CU SN	Level-3-260C-168 HR	-40 to 125	AJA	<a href="#">Samples</a>
LMH6554LEX/NOPB	ACTIVE	UQFN	NHJ	14	4500	Green (RoHS & no Sb/Br)	CU SN	Level-3-260C-168 HR	-40 to 125	AJA	<a href="#">Samples</a>

(1) The marketing status values are defined as follows:

**ACTIVE:** Product device recommended for new designs.

**LIFEBUY:** TI has announced that the device will be discontinued, and a lifetime-buy period is in effect.

**NRND:** Not recommended for new designs. Device is in production to support existing customers, but TI does not recommend using this part in a new design.

**PREVIEW:** Device has been announced but is not in production. Samples may or may not be available.

**OBsolete:** TI has discontinued the production of the device.

(2) Eco Plan - The planned eco-friendly classification: Pb-Free (RoHS), Pb-Free (RoHS Exempt), or Green (RoHS & no Sb/Br) - please check <http://www.ti.com/productcontent> for the latest availability information and additional product content details.

**TBD:** The Pb-Free/Green conversion plan has not been defined.

**Pb-Free (RoHS):** TI's terms "Lead-Free" or "Pb-Free" mean semiconductor products that are compatible with the current RoHS requirements for all 6 substances, including the requirement that lead not exceed 0.1% by weight in homogeneous materials. Where designed to be soldered at high temperatures, TI Pb-Free products are suitable for use in specified lead-free processes.

**Pb-Free (RoHS Exempt):** This component has a RoHS exemption for either 1) lead-based flip-chip solder bumps used between the die and package, or 2) lead-based die adhesive used between the die and leadframe. The component is otherwise considered Pb-Free (RoHS compatible) as defined above.

**Green (RoHS & no Sb/Br):** TI defines "Green" to mean Pb-Free (RoHS compatible), and free of Bromine (Br) and Antimony (Sb) based flame retardants (Br or Sb do not exceed 0.1% by weight in homogeneous material)

(3) MSL, Peak Temp. - The Moisture Sensitivity Level rating according to the JEDEC industry standard classifications, and peak solder temperature.

(4) There may be additional marking, which relates to the logo, the lot trace code information, or the environmental category on the device.

(5) Multiple Device Markings will be inside parentheses. Only one Device Marking contained in parentheses and separated by a "~" will appear on a device. If a line is indented then it is a continuation of the previous line and the two combined represent the entire Device Marking for that device.

(6) Lead/Ball Finish - Orderable Devices may have multiple material finish options. Finish options are separated by a vertical ruled line. Lead/Ball Finish values may wrap to two lines if the finish value exceeds the maximum column width.

**Important Information and Disclaimer:** The information provided on this page represents TI's knowledge and belief as of the date that it is provided. TI bases its knowledge and belief on information provided by third parties, and makes no representation or warranty as to the accuracy of such information. Efforts are underway to better integrate information from third parties. TI has taken and

continues to take reasonable steps to provide representative and accurate information but may not have conducted destructive testing or chemical analysis on incoming materials and chemicals. TI and TI suppliers consider certain information to be proprietary, and thus CAS numbers and other limited information may not be available for release.

In no event shall TI's liability arising out of such information exceed the total purchase price of the TI part(s) at issue in this document sold by TI to Customer on an annual basis.

**TAPE AND REEL INFORMATION**

**QUADRANT ASSIGNMENTS FOR PIN 1 ORIENTATION IN TAPE**

\*All dimensions are nominal

Device	Package Type	Package Drawing	Pins	SPQ	Reel Diameter (mm)	Reel Width W1 (mm)	A0 (mm)	B0 (mm)	K0 (mm)	P1 (mm)	W (mm)	Pin1 Quadrant
LMH6554LE/NOPB	UQFN	NHJ	14	1000	178.0	12.4	2.8	2.8	1.0	8.0	12.0	Q1
LMH6554LEE/NOPB	UQFN	NHJ	14	250	178.0	12.4	2.8	2.8	1.0	8.0	12.0	Q1
LMH6554LEX/NOPB	UQFN	NHJ	14	4500	330.0	12.4	2.8	2.8	1.0	8.0	12.0	Q1

**TAPE AND REEL BOX DIMENSIONS**

\*All dimensions are nominal

Device	Package Type	Package Drawing	Pins	SPQ	Length (mm)	Width (mm)	Height (mm)
LMH6554LE/NOPB	UQFN	NHJ	14	1000	210.0	185.0	35.0
LMH6554LEE/NOPB	UQFN	NHJ	14	250	210.0	185.0	35.0
LMH6554LEX/NOPB	UQFN	NHJ	14	4500	367.0	367.0	35.0

NHJ0014A

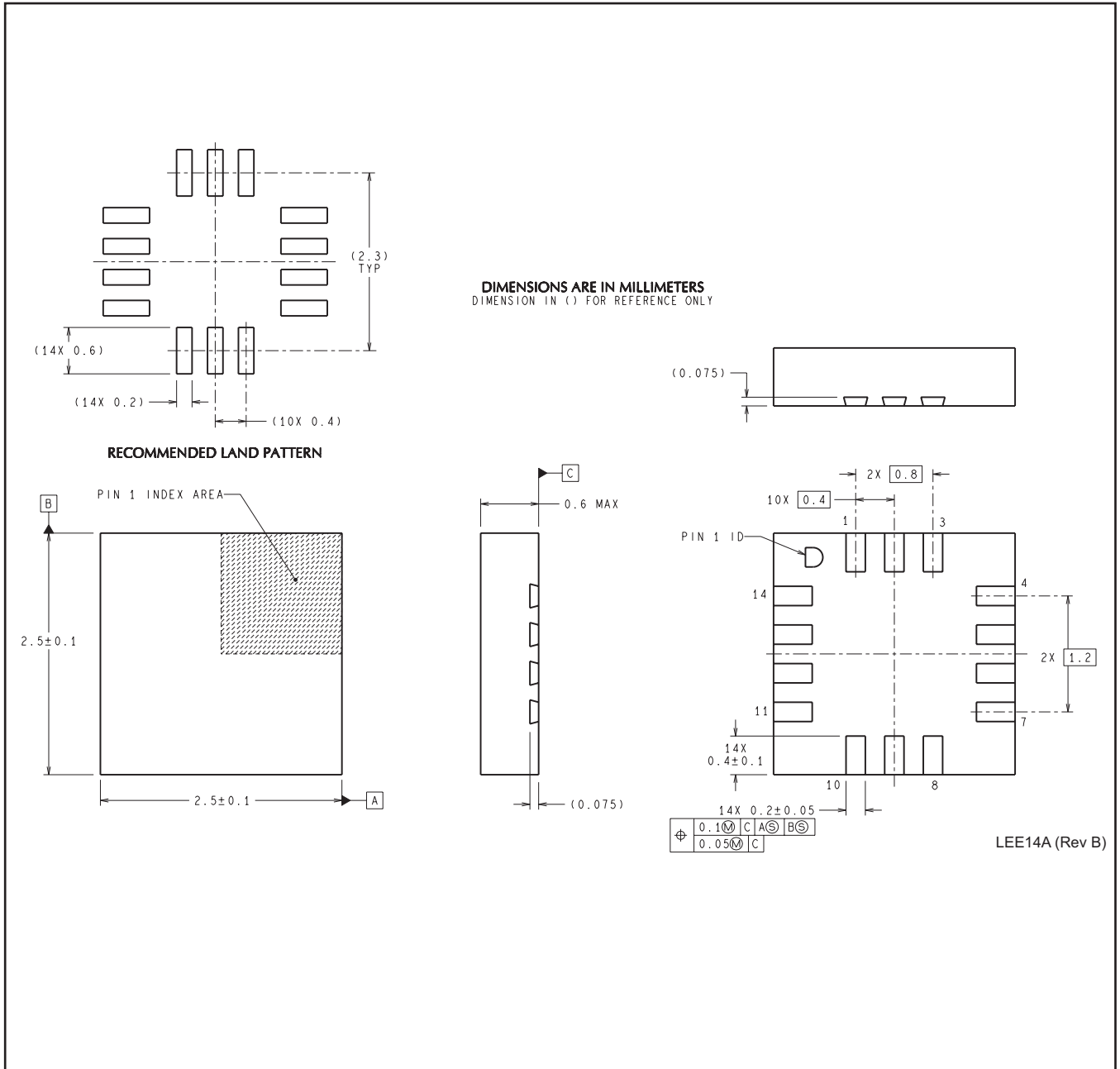

## IMPORTANT NOTICE

Texas Instruments Incorporated and its subsidiaries (TI) reserve the right to make corrections, enhancements, improvements and other changes to its semiconductor products and services per JESD46, latest issue, and to discontinue any product or service per JESD48, latest issue. Buyers should obtain the latest relevant information before placing orders and should verify that such information is current and complete. All semiconductor products (also referred to herein as "components") are sold subject to TI's terms and conditions of sale supplied at the time of order acknowledgment.

TI warrants performance of its components to the specifications applicable at the time of sale, in accordance with the warranty in TI's terms and conditions of sale of semiconductor products. Testing and other quality control techniques are used to the extent TI deems necessary to support this warranty. Except where mandated by applicable law, testing of all parameters of each component is not necessarily performed.

TI assumes no liability for applications assistance or the design of Buyers' products. Buyers are responsible for their products and applications using TI components. To minimize the risks associated with Buyers' products and applications, Buyers should provide adequate design and operating safeguards.

TI does not warrant or represent that any license, either express or implied, is granted under any patent right, copyright, mask work right, or other intellectual property right relating to any combination, machine, or process in which TI components or services are used. Information published by TI regarding third-party products or services does not constitute a license to use such products or services or a warranty or endorsement thereof. Use of such information may require a license from a third party under the patents or other intellectual property of the third party, or a license from TI under the patents or other intellectual property of TI.

Reproduction of significant portions of TI information in TI data books or data sheets is permissible only if reproduction is without alteration and is accompanied by all associated warranties, conditions, limitations, and notices. TI is not responsible or liable for such altered documentation. Information of third parties may be subject to additional restrictions.

Resale of TI components or services with statements different from or beyond the parameters stated by TI for that component or service voids all express and any implied warranties for the associated TI component or service and is an unfair and deceptive business practice. TI is not responsible or liable for any such statements.

Buyer acknowledges and agrees that it is solely responsible for compliance with all legal, regulatory and safety-related requirements concerning its products, and any use of TI components in its applications, notwithstanding any applications-related information or support that may be provided by TI. Buyer represents and agrees that it has all the necessary expertise to create and implement safeguards which anticipate dangerous consequences of failures, monitor failures and their consequences, lessen the likelihood of failures that might cause harm and take appropriate remedial actions. Buyer will fully indemnify TI and its representatives against any damages arising out of the use of any TI components in safety-critical applications.

In some cases, TI components may be promoted specifically to facilitate safety-related applications. With such components, TI's goal is to help enable customers to design and create their own end-product solutions that meet applicable functional safety standards and requirements. Nonetheless, such components are subject to these terms.

No TI components are authorized for use in FDA Class III (or similar life-critical medical equipment) unless authorized officers of the parties have executed a special agreement specifically governing such use.

Only those TI components which TI has specifically designated as military grade or "enhanced plastic" are designed and intended for use in military/aerospace applications or environments. Buyer acknowledges and agrees that any military or aerospace use of TI components which have **not** been so designated is solely at the Buyer's risk, and that Buyer is solely responsible for compliance with all legal and regulatory requirements in connection with such use.

TI has specifically designated certain components as meeting ISO/TS16949 requirements, mainly for automotive use. In any case of use of non-designated products, TI will not be responsible for any failure to meet ISO/TS16949.

### Products

Audio	<a href="http://www.ti.com/audio">www.ti.com/audio</a>
Amplifiers	<a href="http://amplifier.ti.com">amplifier.ti.com</a>
Data Converters	<a href="http://dataconverter.ti.com">dataconverter.ti.com</a>
DLP® Products	<a href="http://www.dlp.com">www.dlp.com</a>
DSP	<a href="http://dsp.ti.com">dsp.ti.com</a>
Clocks and Timers	<a href="http://www.ti.com/clocks">www.ti.com/clocks</a>
Interface	<a href="http://interface.ti.com">interface.ti.com</a>
Logic	<a href="http://logic.ti.com">logic.ti.com</a>
Power Mgmt	<a href="http://power.ti.com">power.ti.com</a>
Microcontrollers	<a href="http://microcontroller.ti.com">microcontroller.ti.com</a>
RFID	<a href="http://www.ti-rfid.com">www.ti-rfid.com</a>
OMAP Applications Processors	<a href="http://www.ti.com/omap">www.ti.com/omap</a>
Wireless Connectivity	<a href="http://www.ti.com/wirelessconnectivity">www.ti.com/wirelessconnectivity</a>

### Applications



Automotive and Transportation	<a href="http://www.ti.com/automotive">www.ti.com/automotive</a>
Communications and Telecom	<a href="http://www.ti.com/communications">www.ti.com/communications</a>
Computers and Peripherals	<a href="http://www.ti.com/computers">www.ti.com/computers</a>
Consumer Electronics	<a href="http://www.ti.com/consumer-apps">www.ti.com/consumer-apps</a>
Energy and Lighting	<a href="http://www.ti.com/energy">www.ti.com/energy</a>
Industrial	<a href="http://www.ti.com/industrial">www.ti.com/industrial</a>
Medical	<a href="http://www.ti.com/medical">www.ti.com/medical</a>
Security	<a href="http://www.ti.com/security">www.ti.com/security</a>
Space, Avionics and Defense	<a href="http://www.ti.com/space-avionics-defense">www.ti.com/space-avionics-defense</a>
Video and Imaging	<a href="http://www.ti.com/video">www.ti.com/video</a>

### TI E2E Community

[e2e.ti.com](http://e2e.ti.com)

## Looking for pricing, stock, or lifecycle information?

Click below to explore more details on WIN SOURCE:

-  [View LMH6554LEE/NOPB on WIN SOURCE](#)
-  [Texas Instruments](#) Information

## Optimize Your Supply Chain with WIN SOURCE Solutions

-  Global Sourcing Solution
-  Obsolete Management
-  Cost Control Management
-  Shortage Management
-  Alternative Solution
-  Excess Inventory Management