



**THE DATASHEET OF
SN74LVC1GX04DRLR**



SN74LVC1GX04 Crystal Oscillator Driver

1 Features

- Available in Texas Instruments NanoStar™ and NanoFree™ Packages
- Supports 5-V V_{CC} Operation
- Inputs Accept Voltages to 5.5 V
- One Unbuffered Inverter (SN74LVC1GU04) and One Buffered Inverter (SN74LVC1G04)
- Suitable for Commonly Used Clock Frequencies:
 - 15 kHz, 3.58 MHz, 4.43 MHz, 13 MHz, 25 MHz, 26 MHz, 27 MHz, 28 MHz
- Maximum t_{pd} of 2.4 ns at 3.3 V
- Low Power Consumption, 10- μ A Maximum I_{CC}
- ± 24 -mA Output Drive at 3.3 V
- I_{off} Supports Partial-Power-Down Mode Operation
- Latch-Up Performance Exceeds 100 mA Per JESD 78, Class II
- ESD Protection Exceeds JESD 22
 - 2000-V Human Body Model (A114-A)
 - 1000-V Charged-Device Model (C101)

2 Applications

- Crystal Oscillators
- Clock Generation

3 Description

The SN74LVC1GX04 device is designed for 1.65-V to 5.5-V V_{CC} operation. This device incorporates the SN74LVC1GU04 (inverter with unbuffered output) and the SN74LVC1G04 (inverter) functions into a single device. The LVC1GX04 is optimized for use in crystal oscillator applications.

X1 and X2 can be connected to a crystal or resonator in oscillator applications. The device provides an additional buffered inverter (Y) for signal conditioning (see Figure 5). The additional buffered inverter improves the signal quality of the crystal oscillator output by making it rail to rail.

NanoStar and NanoFree package technology is a major breakthrough in IC packaging concepts, using the die as the package.

This device is fully specified for partial-power-down applications using I_{off} (Y output only). The I_{off} circuitry disables the outputs, preventing damaging current backflow through the device when it is powered down.

Device Information⁽¹⁾

PART NUMBER	PACKAGE	BODY SIZE (NOM)
SN74LVC1GX04DB V	SOT-23 (6)	2.90 mm x 1.60 mm
SN74LVC1GX04DC K	SC70 (6)	2.00 mm x 1.25 mm
SN74LVC1GX04DR L	SOT (6)	1.60 mm x 1.20 mm

(1) For all available packages, see the orderable addendum at the end of the data sheet.

Functional Block Diagram

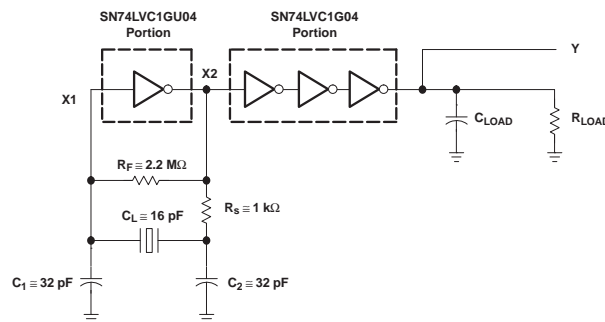

a) Logic Diagram View

SN74LVC1GX04 includes both dotted portions



Table of Contents

1	Features	1	8.1	Overview	10
2	Applications	1	8.2	Functional Block Diagram	10
3	Description	1	8.3	Feature Description	10
4	Revision History	2	8.4	Device Functional Modes	10
5	Pin Configuration and Functions	3	9	Application and Implementation	11
6	Specifications	4	9.1	Application Information	11
6.1	Absolute Maximum Ratings	4	9.2	Typical Application	11
6.2	ESD Ratings	4	10	Power Supply Recommendations	14
6.3	Recommended Operating Conditions	4	11	Layout	15
6.4	Thermal Information	5	11.1	Layout Guidelines	15
6.5	Electrical Characteristics	5	11.2	Layout Example	15
6.6	Switching Characteristics, SN74LVC1GX04	6	12	Device and Documentation Support	16
6.7	Switching Characteristics, SN74LVC1GX04	6	12.1	Documentation Support	16
6.8	Switching Characteristics, SN74LVC1GX04	6	12.2	Community Resources	16
6.9	Operating Characteristics	6	12.3	Trademarks	16
6.10	Typical Characteristics	7	12.4	Electrostatic Discharge Caution	16
7	Parameter Measurement Information	8	12.5	Glossary	16
8	Detailed Description	10	13	Mechanical, Packaging, and Orderable Information	16

4 Revision History

Changes from Revision C (December 2013) to Revision D

Page

- Added *Pin Configuration and Functions* section, *ESD Ratings* table, *Feature Description* section, *Device Functional Modes*, *Application and Implementation* section, *Power Supply Recommendations* section, *Layout* section, *Device and Documentation Support* section, and *Mechanical, Packaging, and Orderable Information* section **1**

5 Pin Configuration and Functions

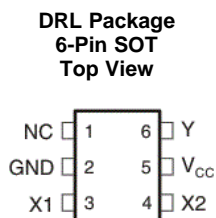
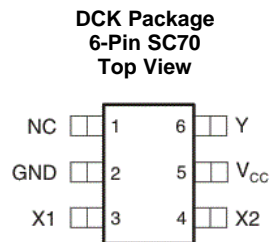
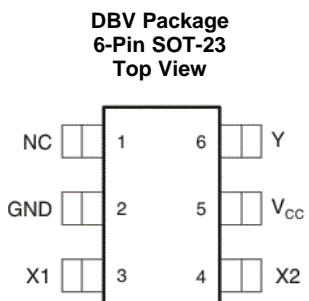

See mechanical drawings for dimensions.

NC – No internal connection.

Pin Functions

PIN		I/O	DESCRIPTION
NAME	NO.		
GND	2	–	Ground
NC	1	–	No internal connection
VCC	5	–	Supply power
X1	3	I	Amplifier input
X2	4	O	Amplifier output
Y	6	O	Main output to other logic

6 Specifications

6.1 Absolute Maximum Ratings

 over operating free-air temperature range (unless otherwise noted)⁽¹⁾

		MIN	MAX	UNIT
V _{CC}	Supply voltage	-0.5	6.5	V
V _I	Input voltage ⁽²⁾	-0.5	6.5	V
V _O	Voltage applied to Y output in the high-impedance or power-off state ⁽²⁾	-0.5	6.5	V
V _O	Voltage applied to any output in the high or low state ⁽²⁾ ⁽³⁾	-0.5	V _{CC} + 0.5	V
I _{IK}	Input clamp current	V _I < 0	-50	mA
I _{OK}	Output clamp current	V _O < 0	-50	mA
I _O	Continuous output current		±50	mA
	Continuous current through V _{CC} or GND		±100	mA
T _J	Junction temperature		150	°C
T _{stg}	Storage temperature	-65	150	°C

(1) Stresses beyond those listed under *Absolute Maximum Ratings* may cause permanent damage to the device. These are stress ratings only, which do not imply functional operation of the device at these or any other conditions beyond those indicated under *Recommended Operating Conditions*. Exposure to absolute-maximum-rated conditions for extended periods may affect device reliability.

(2) The input and output negative-voltage ratings may be exceeded if the input and output current ratings are observed.

(3) The value of V_{CC} is provided in the recommended operating conditions table.

6.2 ESD Ratings

		VALUE	UNIT
V _(ESD)	Electrostatic discharge	Human body model (HBM), per AEC Q100-002 ⁽¹⁾	±2000
		Charged-device model (CDM), per AEC Q100-011	±1000

(1) AEC Q100-002 indicates that HBM stressing shall be in accordance with the ANSI/ESDA/JEDEC JS-001 specification.

6.3 Recommended Operating Conditions⁽¹⁾

		MIN	MAX	UNIT
V _{CC}	Supply voltage	Operating	1.65	5.5
		Data retention only	1.5	
		Crystal oscillator use	2	
V _{IH}	High-level input voltage	V _{CC} = 1.65 V to 5.5 V	0.75 × V _{CC}	V
V _{IL}	Low-level input voltage	V _{CC} = 1.65 V to 5.5 V	0.25 × V _{CC}	V
V _I	Input voltage	0	5.5	V
V _O	Output voltage	X2, Y	0	V _{CC}
		Y output only, Power-down mode, V _{CC} = 0 V	0	5.5
I _{OH}	High-level output current	V _{CC} = 1.65 V		-4
		V _{CC} = 2.3 V		-8
		V _{CC} = 3 V		-16
		V _{CC} = 4.5 V		-24
I _{OL}	Low-level output current	V _{CC} = 1.65 V		4
		V _{CC} = 2.3 V		8
		V _{CC} = 3 V		16
		V _{CC} = 4.5 V		24

(1) All unused inputs of the device must be held at V_{CC} or GND to ensure proper device operation. Refer to the TI application report, *Implications of Slow or Floating CMOS Inputs*, [SCBA004](#).

Recommended Operating Conditions⁽¹⁾ (continued)

			MIN	MAX	UNIT
$\Delta t/\Delta v$	Input transition rise or fall rate	$V_{CC} = 1.8\text{ V} \pm 0.15\text{ V}, 2.5\text{ V} \pm 0.2\text{ V}$		20	ns/V
		$V_{CC} = 3.3\text{ V} \pm 0.3\text{ V}$		10	
		$V_{CC} = 5\text{ V} \pm 0.5\text{ V}$		10	
T_A	Operating free-air temperature		-40	125	°C

6.4 Thermal Information

THERMAL METRIC ⁽¹⁾	SN74LVC1GX04			UNIT	
	DBV (SOT-23)	DCK (SC70)	DRL (SOT)		
	6 PINS	6 PINS	6 PINS		
$R_{\theta JA}$	Junction-to-ambient thermal resistance	165	259	142	°C/W

(1) For more information about traditional and new thermal metrics, see the *Semiconductor and IC Package Thermal Metrics* application report, [SPRA953](#).

6.5 Electrical Characteristics

over recommended operating free-air temperature range (unless otherwise noted)

PARAMETER	TEST CONDITIONS			V_{CC}	MIN	TYP ⁽¹⁾	MAX	UNIT	
V_{OH}		$I_{OH} = -100\ \mu\text{A}$ $I_{OH} = -4\ \text{mA}$ $I_{OH} = -8\ \text{mA}$ $I_{OH} = -16\ \text{mA}$ $I_{OH} = -24\ \text{mA}$ $I_{OH} = -32\ \text{mA}$	$V_I = 5.5\ \text{V or GND}$	$T_A = -40^\circ\text{C to } 125^\circ\text{C}$	1.65 V to 5.5 V	$V_{CC} - 0.1$		V	
					1.65 V	1.2			
					2.3 V	1.9			
					3 V	2.4			
						2.3			
					4.5 V	3.8			
V_{OL}		$I_{OL} = 100\ \mu\text{A}$ $I_{OL} = 4\ \text{mA}$ $I_{OL} = 8\ \text{mA}$ $I_{OL} = 16\ \text{mA}$ $I_{OL} = 24\ \text{mA}$ $I_{OL} = 32\ \text{mA}$	$V_I = 5.5\ \text{V or GND}$	$T_A = -40^\circ\text{C to } 125^\circ\text{C}$	1.65 V to 5.5 V		0.1	V	
					1.65 V		0.45		
					2.3 V		0.3		
					$T_A = -40^\circ\text{C to } 125^\circ\text{C}$	3 V			0.4
					$T_A = -40^\circ\text{C to } 85^\circ\text{C}$	3 V			0.55
					$T_A = -40^\circ\text{C to } 125^\circ\text{C}$				0.63
					$T_A = -40^\circ\text{C to } 85^\circ\text{C}$	4.5 V			0.55
					$T_A = -40^\circ\text{C to } 125^\circ\text{C}$				0.7
I_I	X1	$V_I = 5.5\ \text{V or GND}$	$T_A = -40^\circ\text{C to } 125^\circ\text{C}$	0 to 5.5 V			±5	μA	
I_{off}	X1, Y	V_I or $V_O = 5.5\ \text{V}$	$T_A = -40^\circ\text{C to } 125^\circ\text{C}$	0			±10	μA	
I_{CC}		$V_I = 5.5\ \text{V or GND}, I_O = 0$	$T_A = -40^\circ\text{C to } 125^\circ\text{C}$	1.65 V to 5.5 V			10	μA	
C_i		$V_I = V_{CC}$ or GND		3.3 V		7		pF	

(1) All typical values are at $V_{CC} = 3.3\ \text{V}$, $T_A = 25^\circ\text{C}$.

SN74LVC1GX04

SCES581D – JULY 2004 – REVISED OCTOBER 2015

www.ti.com

6.6 Switching Characteristics, SN74LVC1GX04

over recommended operating free-air temperature range, $C_L = 15$ pF (unless otherwise noted) (see Figure 2)

PARAMETER	FROM (INPUT)	TO (OUTPUT)	TEMPERATURE	V_{CC}	MIN	MAX	UNIT
t_{pd}	X1	X2	–40°C to 85°C	$V_{CC} = 1.8\text{ V} \pm 0.15\text{ V}$	1	4	ns
				$V_{CC} = 2.5\text{ V} \pm 0.2\text{ V}$	0.8	2.6	
				$V_{CC} = 3.3\text{ V} \pm 0.3\text{ V}$	0.6	2.4	
				$V_{CC} = 5\text{ V} \pm 0.5\text{ V}$	0.5	2	
		Y ⁽¹⁾	–40°C to 85°C	$V_{CC} = 1.8\text{ V} \pm 0.15\text{ V}$	3.5	10	
				$V_{CC} = 2.5\text{ V} \pm 0.2\text{ V}$	2.2	6	
				$V_{CC} = 3.3\text{ V} \pm 0.3\text{ V}$	2	5	
				$V_{CC} = 5\text{ V} \pm 0.5\text{ V}$	1.5	3.5	

(1) X2 – no external load

6.7 Switching Characteristics, SN74LVC1GX04

over recommended operating free-air temperature range, $C_L = 30$ pF or 50 pF (unless otherwise noted) (see Figure 3)

PARAMETER	FROM (INPUT)	TO (OUTPUT)	TEMPERATURE	V_{CC}	MIN	MAX	UNIT
t_{pd}	X1	X2	–40°C to 85°C	$V_{CC} = 1.8\text{ V} \pm 0.15\text{ V}$	1.1	7	ns
				$V_{CC} = 2.5\text{ V} \pm 0.2\text{ V}$	0.8	4	
				$V_{CC} = 3.3\text{ V} \pm 0.3\text{ V}$	0.8	3.7	
				$V_{CC} = 5\text{ V} \pm 0.5\text{ V}$	0.8	3	
		Y ⁽¹⁾	–40°C to 85°C	$V_{CC} = 1.8\text{ V} \pm 0.15\text{ V}$	3.8	18	
				$V_{CC} = 2.5\text{ V} \pm 0.2\text{ V}$	2	7.4	
				$V_{CC} = 3.3\text{ V} \pm 0.3\text{ V}$	2	7.8	
				$V_{CC} = 5\text{ V} \pm 0.5\text{ V}$	2	5	

(1) X2 – no external load

6.8 Switching Characteristics, SN74LVC1GX04

over recommended operating free-air temperature range, $C_L = 30$ pF or 50 pF (unless otherwise noted) (see Figure 3)

PARAMETER	FROM (INPUT)	TO (OUTPUT)	TEMPERATURE	V_{CC}	MIN	MAX	UNIT
t_{pd}	X1	X2	–40°C to 125°C	$V_{CC} = 1.8\text{ V} \pm 0.15\text{ V}$	1.1	8	ns
				$V_{CC} = 2.5\text{ V} \pm 0.2\text{ V}$	0.8	5	
				$V_{CC} = 3.3\text{ V} \pm 0.3\text{ V}$	0.8	4.3	
				$V_{CC} = 5\text{ V} \pm 0.5\text{ V}$	0.8	3.5	
		Y ⁽¹⁾	–40°C to 125°C	$V_{CC} = 1.8\text{ V} \pm 0.15\text{ V}$	3.8	20	
				$V_{CC} = 2.5\text{ V} \pm 0.2\text{ V}$	2	8.4	
				$V_{CC} = 3.3\text{ V} \pm 0.3\text{ V}$	2	8.8	
				$V_{CC} = 5\text{ V} \pm 0.5\text{ V}$	2	5.5	

(1) X2 – no external load

6.9 Operating Characteristics

$T_A = 25^\circ\text{C}$

PARAMETER	TEST CONDITIONS	V_{CC}	TYP	UNIT
C_{pd} Power dissipation capacitance	$f = 10\text{ MHz}$	$V_{CC} = 1.8\text{ V}$	22	pF
		$V_{CC} = 2.5\text{ V}$	22	
		$V_{CC} = 3.3\text{ V}$	24	
		$V_{CC} = 5\text{ V}$	35	

6.10 Typical Characteristics

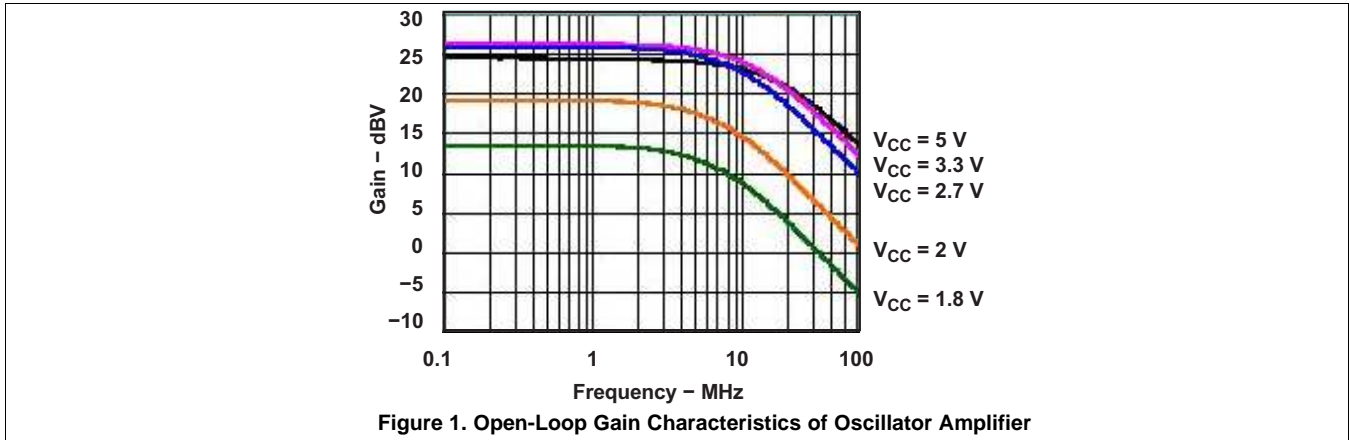

7 Parameter Measurement Information

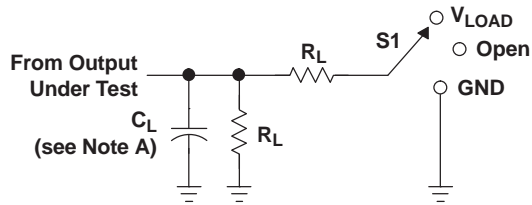
LOAD CIRCUIT

TEST	S1
t_{PLH}/t_{PHL}	Open
t_{PLZ}/t_{PZL}	V_{LOAD}
t_{PHZ}/t_{PZH}	GND

V_{CC}	INPUTS		V_M	V_{LOAD}	C_L	R_L	V_{Δ}
	V_I	t_r/t_f					
$1.8\text{ V} \pm 0.15\text{ V}$	V_{CC}	$\leq 2\text{ ns}$	$V_{CC}/2$	$2 \times V_{CC}$	15 pF	1 M Ω	0.15 V
$2.5\text{ V} \pm 0.2\text{ V}$	V_{CC}	$\leq 2\text{ ns}$	$V_{CC}/2$	$2 \times V_{CC}$	15 pF	1 M Ω	0.15 V
$3.3\text{ V} \pm 0.3\text{ V}$	3 V	$\leq 2.5\text{ ns}$	1.5 V	6 V	15 pF	1 M Ω	0.3 V
$5\text{ V} \pm 0.5\text{ V}$	V_{CC}	$\leq 2.5\text{ ns}$	$V_{CC}/2$	$2 \times V_{CC}$	15 pF	1 M Ω	0.3 V

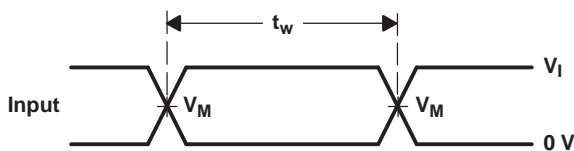
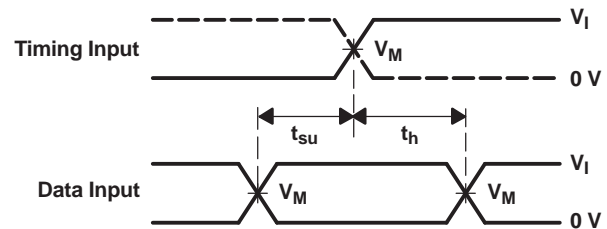
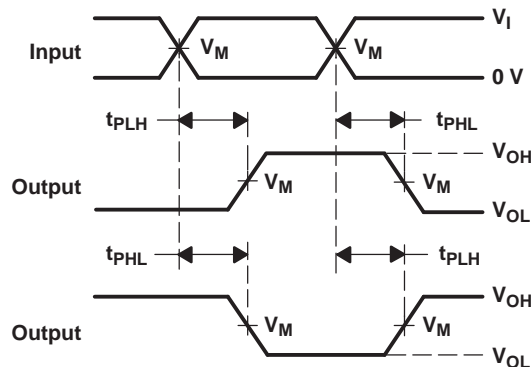
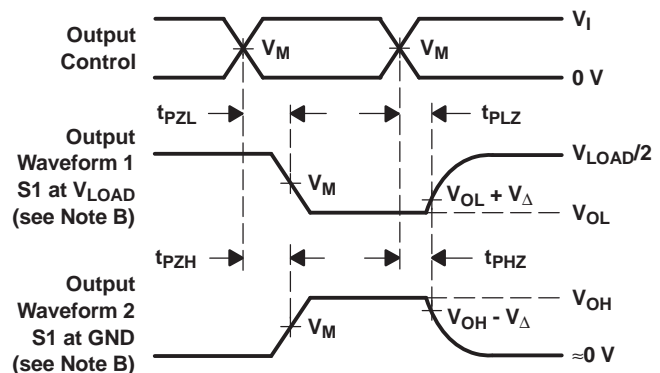
**VOLTAGE WAVEFORMS
PULSE DURATION**

**VOLTAGE WAVEFORMS
SETUP AND HOLD TIMES**

**VOLTAGE WAVEFORMS
PROPAGATION DELAY TIMES
INVERTING AND NONINVERTING OUTPUTS**

**VOLTAGE WAVEFORMS
ENABLE AND DISABLE TIMES
LOW- AND HIGH-LEVEL ENABLING**

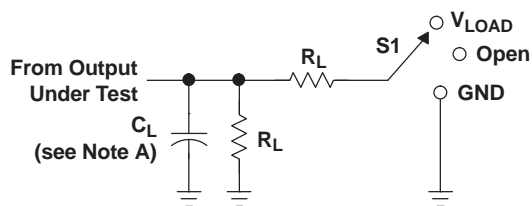
- NOTES:
- C_L includes probe and jig capacitance.
 - Waveform 1 is for an output with internal conditions such that the output is low, except when disabled by the output control. Waveform 2 is for an output with internal conditions such that the output is high, except when disabled by the output control.
 - All input pulses are supplied by generators having the following characteristics: $PRR \leq 10\text{ MHz}$, $Z_O = 50\ \Omega$.
 - The outputs are measured one at a time, with one transition per measurement.
 - t_{PLZ} and t_{PHZ} are the same as t_{dis} .
 - t_{PZL} and t_{PZH} are the same as t_{en} .
 - t_{PLH} and t_{PHL} are the same as t_{pd} .
 - All parameters and waveforms are not applicable to all devices.

Figure 2. Load Circuit and Voltage Waveforms

Parameter Measurement Information (continued)



LOAD CIRCUIT

TEST	S1
t_{PLH}/t_{PHL}	Open
t_{PLZ}/t_{PZL}	V_{LOAD}
t_{PHZ}/t_{PZH}	GND

V_{CC}	INPUTS		V_M	V_{LOAD}	C_L	R_L	V_{Δ}
	V_I	t_r/t_f					
$1.8 V \pm 0.15 V$	V_{CC}	$\leq 2 \text{ ns}$	$V_{CC}/2$	$2 \times V_{CC}$	30 pF	1 k Ω	0.15 V
$2.5 V \pm 0.2 V$	V_{CC}	$\leq 2 \text{ ns}$	$V_{CC}/2$	$2 \times V_{CC}$	30 pF	500 Ω	0.15 V
$3.3 V \pm 0.3 V$	3 V	$\leq 2.5 \text{ ns}$	1.5 V	6 V	50 pF	500 Ω	0.3 V
$5 V \pm 0.5 V$	V_{CC}	$\leq 2.5 \text{ ns}$	$V_{CC}/2$	$2 \times V_{CC}$	50 pF	500 Ω	0.3 V

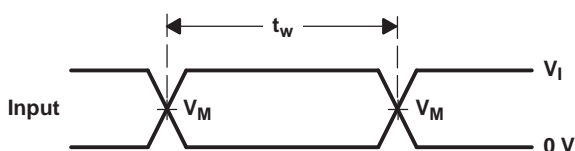

VOLTAGE WAVEFORMS PULSE DURATION

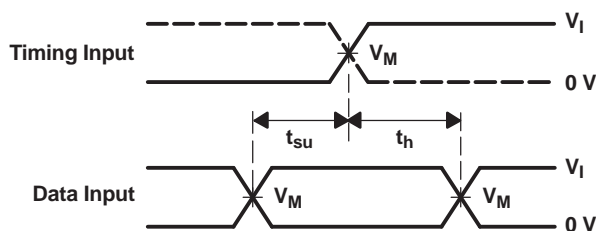

VOLTAGE WAVEFORMS SETUP AND HOLD TIMES

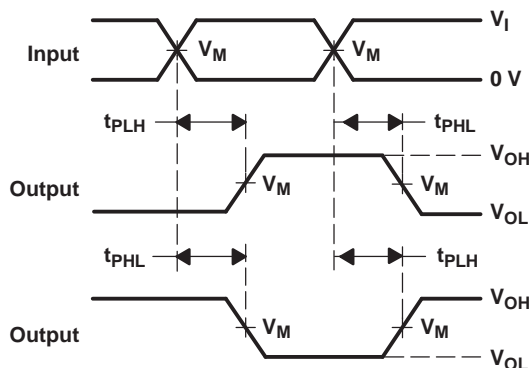

VOLTAGE WAVEFORMS PROPAGATION DELAY TIMES INVERTING AND NONINVERTING OUTPUTS

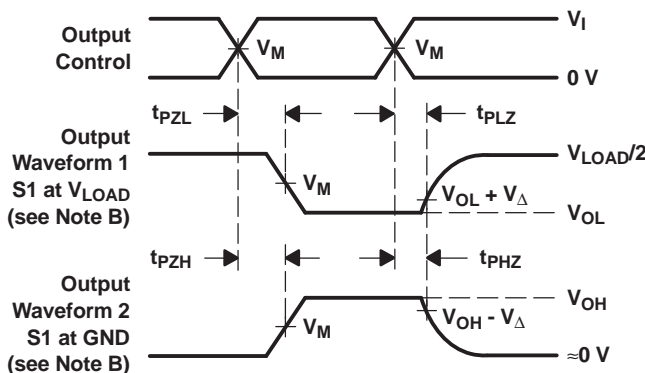

VOLTAGE WAVEFORMS ENABLE AND DISABLE TIMES LOW- AND HIGH-LEVEL ENABLING

- NOTES:
- A. C_L includes probe and jig capacitance.
 - B. Waveform 1 is for an output with internal conditions such that the output is low, except when disabled by the output control. Waveform 2 is for an output with internal conditions such that the output is high, except when disabled by the output control.
 - C. All input pulses are supplied by generators having the following characteristics: $PRR \leq 10 \text{ MHz}$, $Z_O = 50 \Omega$.
 - D. The outputs are measured one at a time, with one transition per measurement.
 - E. t_{PLZ} and t_{PHZ} are the same as t_{dis} .
 - F. t_{PZL} and t_{PZH} are the same as t_{en} .
 - G. t_{PLH} and t_{PHL} are the same as t_{pd} .
 - H. All parameters and waveforms are not applicable to all devices.

Figure 3. Load Circuit and Voltage Waveforms

8 Detailed Description

8.1 Overview

The SN74LVC1GX04 is optimized for creating a crystal oscillator circuit with a buffered square-wave output. This device is fully specified for partial-power-down applications using I_{off} (Y output only). The I_{off} circuitry disables the outputs, preventing damaging current back-flow through the device when it is powered down.

8.2 Functional Block Diagram

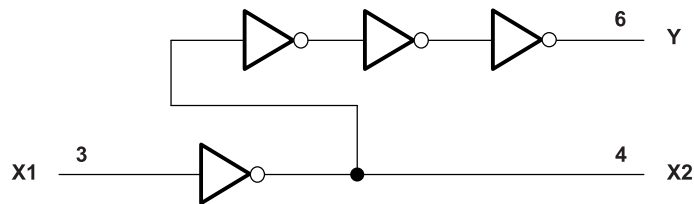

Figure 4. Logic Diagram (Positive Logic)

8.3 Feature Description

The first inverter is used as a linear amplifier for crystal oscillator.

The last three inverters ensure a fast edge square-wave at the Y output.

8.4 Device Functional Modes

The only intended device use is to generate a square-wave output using a crystal to set the operating frequency.

Table 1. Function Table

INPUT X1	OUTPUTS	
	X2	Y
H	L	H
L	H	L

9 Application and Implementation

NOTE

Information in the following applications sections is not part of the TI component specification, and TI does not warrant its accuracy or completeness. TI's customers are responsible for determining suitability of components for their purposes. Customers should validate and test their design implementation to confirm system functionality.

9.1 Application Information

The SN74LVC1GX04 contains a buffered and unbuffered inverter for the specific purpose of creating a crystal oscillator and driver with limited external components.

9.2 Typical Application

Figure 5 shows a typical application of the SN74LVC1GX04 in a Pierce oscillator circuit. The buffered inverter (SN74LVC1G04 portion) produces a rail-to-rail voltage waveform. The recommended load for the crystal shown in this example is 16 pF. The value of the recommended load (C_L) can be found in the crystal manufacturer's data sheet.

Values of C_1 and C_2 are chosen to calculate C_L in Equation 1 where $C_1 \equiv C_2$.

$$C_L = \frac{C_1 C_2}{C_1 + C_2} \quad (1)$$

R_s is the current-limiting resistor, and the value depends on the maximum power dissipation of the crystal. Generally, the recommended value of R_s is specified in the crystal manufacturer's data sheet and, usually, this value is approximately equal to the reactance of C_2 at resonance frequency, that is seen in Equation 2.

$$R_s = X_{C_2} \quad (2)$$

R_F is the feedback resistor that is used to bias the inverter in the linear region of operation. Usually, the value is chosen to be within 1 M Ω to 10 M Ω .

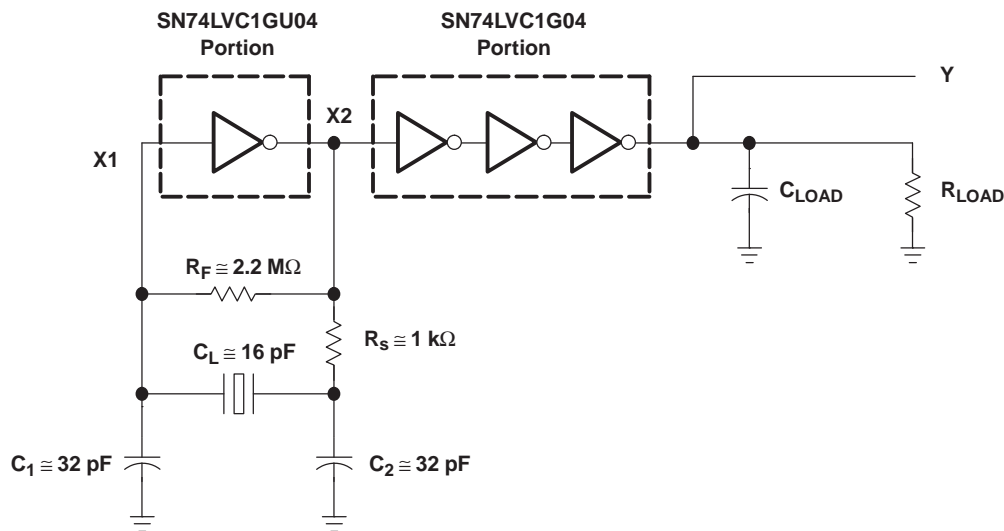

a) Logic Diagram View

Figure 5. Oscillator Circuit

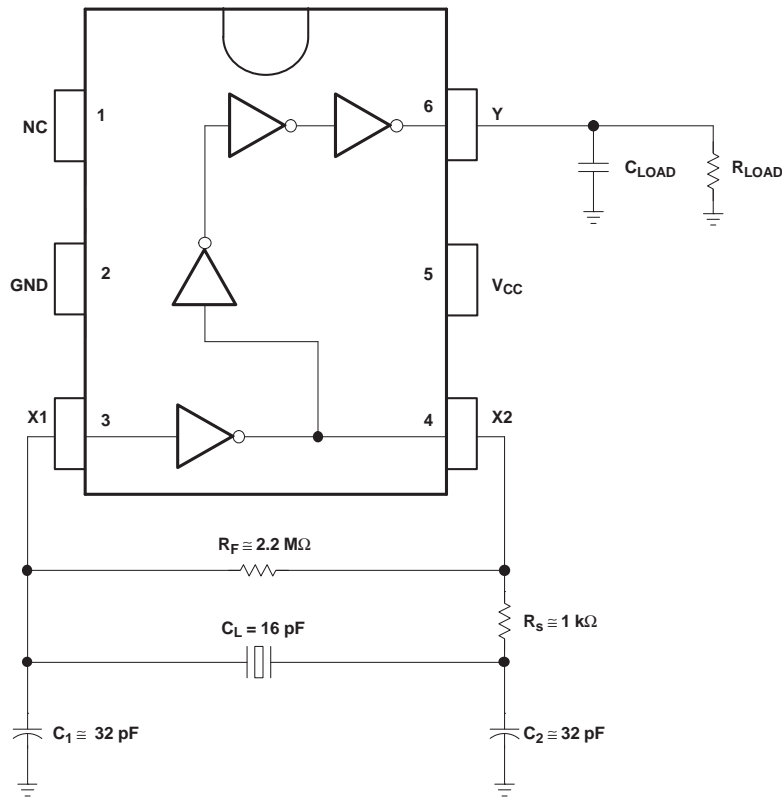
Typical Application (continued)

b) Oscillator Circuit in DBV or DCK Pinout

Figure 6. Oscillator Circuit (Continued)
9.2.1 Design Requirements

The open-loop gain of the unbuffered inverter decreases as power-supply voltage decreases. This decreases the closed-loop gain of the oscillator circuit. The value of R_s can be decreased to increase the closed-loop gain, while maintaining the power dissipation of the crystal within the maximum limit.

R_s and C_2 form a low-pass filter and reduce spurious oscillations. Component values can be adjusted, based on the desired cutoff frequency.

C_2 can be increased over C_1 to increase the phase shift and help in start-up of the oscillator. Increasing C_2 may affect the duty cycle of the output voltage.

At high frequency, phase shift due to R_s becomes significant. In this case, R_s can be replaced by a capacitor to reduce the phase shift.

9.2.2 Detailed Design Procedure

After the selection of proper component values, the oscillator circuit should be tested using these components. To ensure that the oscillator circuit performs within the *Recommended Operating Conditions*⁽¹⁾, follow these steps:

1. Without a crystal, the oscillator circuit should not oscillate. To check this, the crystal can be replaced by its equivalent parallel-resonance resistance.
2. When the power-supply voltage drops, the closed-loop gain of the oscillator circuit reduces. Ensure that the circuit oscillates at the appropriate frequency at the lowest V_{CC} and highest V_{CC} .
3. Ensure that the duty cycle, start-up time, and frequency drift over time is within the system requirements.

(1) All unused inputs of the device must be held at V_{CC} or GND to ensure proper device operation. Refer to the TI application report, *Implications of Slow or Floating CMOS Inputs*, SCBA004.

Typical Application (continued)

9.2.3 Application Curve

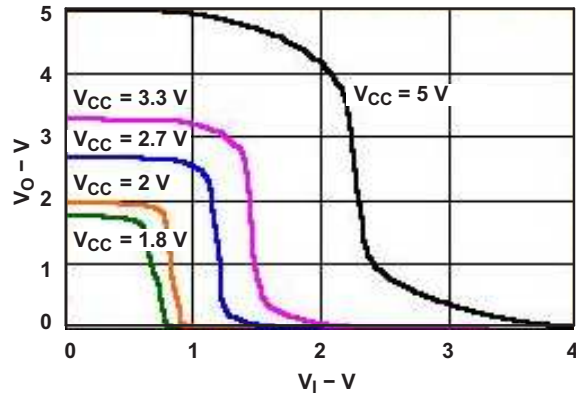

Figure 7. V_O vs V_I Characteristics of Oscillator Amplifier

10 Power Supply Recommendations

The power supply can be any voltage between the minimum and maximum supply voltage rating located in [Recommended Operating Conditions^{\(1\)}](#) table.

Each V_{CC} terminal should have a good bypass capacitor to prevent power disturbance. For devices with a single supply, a 0.1- μ F capacitor is recommended. If there are multiple V_{CC} terminals then 0.01- μ F or 0.022- μ F capacitors are recommended for each power terminal. It is ok to parallel multiple bypass capacitors to reject different frequencies of noise. Multiple bypass capacitors may be paralleled to reject different frequencies of noise. The bypass capacitor should be installed as close to the power terminal as possible for the best results.

11 Layout

11.1 Layout Guidelines

When using multiple bit logic devices, inputs should not float. In many cases, functions or parts of functions of digital logic devices are unused. Some examples are when only two inputs of a triple-input AND gate are used, or when only 3 of the 4-buffer gates are used. Such input pins should not be left unconnected because the undefined voltages at the outside connections result in undefined operational states.

Specified in [Figure 8](#) are rules that must be observed under all circumstances. All unused inputs of digital logic devices must be connected to a high or low bias to prevent them from floating. The logic level that should be applied to any particular unused input depends on the function of the device. Generally they will be tied to GND or V_{CC} , whichever makes more sense or is more convenient.

11.2 Layout Example

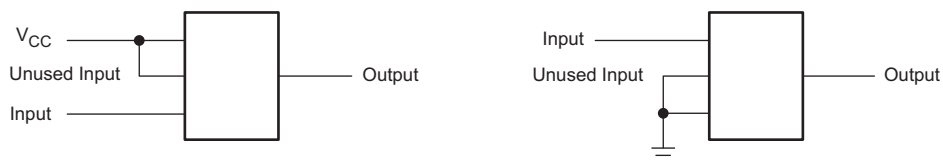

Figure 8. Layout Diagram

12 Device and Documentation Support

12.1 Documentation Support

12.1.1 Related Documentation

For related documentation, see the following:

Implications of Slow or Floating CMOS Inputs, [SCBA004](#)

12.2 Community Resources

The following links connect to TI community resources. Linked contents are provided "AS IS" by the respective contributors. They do not constitute TI specifications and do not necessarily reflect TI's views; see TI's [Terms of Use](#).

TI E2E™ Online Community *TI's Engineer-to-Engineer (E2E) Community*. Created to foster collaboration among engineers. At [e2e.ti.com](#), you can ask questions, share knowledge, explore ideas and help solve problems with fellow engineers.

Design Support *TI's Design Support* Quickly find helpful E2E forums along with design support tools and contact information for technical support.

12.3 Trademarks

NanoStar, NanoFree, E2E are trademarks of Texas Instruments. All other trademarks are the property of their respective owners.

12.4 Electrostatic Discharge Caution



These devices have limited built-in ESD protection. The leads should be shorted together or the device placed in conductive foam during storage or handling to prevent electrostatic damage to the MOS gates.

12.5 Glossary

[SLYZ022](#) — *TI Glossary*.

This glossary lists and explains terms, acronyms, and definitions.

13 Mechanical, Packaging, and Orderable Information

The following pages include mechanical, packaging, and orderable information. This information is the most current data available for the designated devices. This data is subject to change without notice and revision of this document. For browser-based versions of this data sheet, refer to the left-hand navigation.

PACKAGING INFORMATION

Orderable Device	Status (1)	Package Type	Package Drawing	Pins	Package Qty	Eco Plan (2)	Lead/Ball Finish (6)	MSL Peak Temp (3)	Op Temp (°C)	Device Marking (4/5)	Samples
74LVC1GX04DCKRE4	ACTIVE	SC70	DCK	6	3000	Green (RoHS & no Sb/Br)	CU NIPDAU	Level-1-260C-UNLIM	-40 to 125	(D25, D2J, D2K, D2R)	Samples
74LVC1GX04DCKTG4	ACTIVE	SC70	DCK	6	250	Green (RoHS & no Sb/Br)	CU NIPDAU	Level-1-260C-UNLIM	-40 to 125	(D25, D2R)	Samples
SN74LVC1GX04DBVR	ACTIVE	SOT-23	DBV	6	3000	Green (RoHS & no Sb/Br)	CU NIPDAU	Level-1-260C-UNLIM	-40 to 125	(CX45, CX4R)	Samples
SN74LVC1GX04DBVT	ACTIVE	SOT-23	DBV	6	250	Green (RoHS & no Sb/Br)	CU NIPDAU	Level-1-260C-UNLIM	-40 to 125	(CX45, CX4R)	Samples
SN74LVC1GX04DCKR	ACTIVE	SC70	DCK	6	3000	Green (RoHS & no Sb/Br)	CU NIPDAU CU SN	Level-1-260C-UNLIM	-40 to 125	(D25, D2J, D2K, D2R)	Samples
SN74LVC1GX04DCKT	ACTIVE	SC70	DCK	6	250	Green (RoHS & no Sb/Br)	CU NIPDAU CU SN	Level-1-260C-UNLIM	-40 to 125	(D25, D2J, D2R)	Samples
SN74LVC1GX04DRLR	ACTIVE	SOT-5X3	DRL	6	4000	Green (RoHS & no Sb/Br)	CU NIPDAU CU NIPDAUAG	Level-1-260C-UNLIM	-40 to 125	(D27, D2R)	Samples

(1) The marketing status values are defined as follows:

ACTIVE: Product device recommended for new designs.

LIFEBUY: TI has announced that the device will be discontinued, and a lifetime-buy period is in effect.

NRND: Not recommended for new designs. Device is in production to support existing customers, but TI does not recommend using this part in a new design.

PREVIEW: Device has been announced but is not in production. Samples may or may not be available.

OBSOLETE: TI has discontinued the production of the device.

(2) **RoHS:** TI defines "RoHS" to mean semiconductor products that are compliant with the current EU RoHS requirements for all 10 RoHS substances, including the requirement that RoHS substance do not exceed 0.1% by weight in homogeneous materials. Where designed to be soldered at high temperatures, "RoHS" products are suitable for use in specified lead-free processes. TI may reference these types of products as "Pb-Free".

RoHS Exempt: TI defines "RoHS Exempt" to mean products that contain lead but are compliant with EU RoHS pursuant to a specific EU RoHS exemption.

Green: TI defines "Green" to mean the content of Chlorine (Cl) and Bromine (Br) based flame retardants meet JS709B low halogen requirements of <=100ppm threshold. Antimony trioxide based flame retardants must also meet the <=1000ppm threshold requirement.

(3) MSL, Peak Temp. - The Moisture Sensitivity Level rating according to the JEDEC industry standard classifications, and peak solder temperature.

(4) There may be additional marking, which relates to the logo, the lot trace code information, or the environmental category on the device.

(5) Multiple Device Markings will be inside parentheses. Only one Device Marking contained in parentheses and separated by a "-" will appear on a device. If a line is indented then it is a continuation of the previous line and the two combined represent the entire Device Marking for that device.

⁽⁶⁾ Lead/Ball Finish - Orderable Devices may have multiple material finish options. Finish options are separated by a vertical ruled line. Lead/Ball Finish values may wrap to two lines if the finish value exceeds the maximum column width.

Important Information and Disclaimer:The information provided on this page represents TI's knowledge and belief as of the date that it is provided. TI bases its knowledge and belief on information provided by third parties, and makes no representation or warranty as to the accuracy of such information. Efforts are underway to better integrate information from third parties. TI has taken and continues to take reasonable steps to provide representative and accurate information but may not have conducted destructive testing or chemical analysis on incoming materials and chemicals. TI and TI suppliers consider certain information to be proprietary, and thus CAS numbers and other limited information may not be available for release.

In no event shall TI's liability arising out of such information exceed the total purchase price of the TI part(s) at issue in this document sold by TI to Customer on an annual basis.

OTHER QUALIFIED VERSIONS OF SN74LVC1GX04 :

- Enhanced Product: [SN74LVC1GX04-EP](#)

NOTE: Qualified Version Definitions:

- Enhanced Product - Supports Defense, Aerospace and Medical Applications

TAPE AND REEL INFORMATION



QUADRANT ASSIGNMENTS FOR PIN 1 ORIENTATION IN TAPE



*All dimensions are nominal

Device	Package Type	Package Drawing	Pins	SPQ	Reel Diameter (mm)	Reel Width W1 (mm)	A0 (mm)	B0 (mm)	K0 (mm)	P1 (mm)	W (mm)	Pin1 Quadrant
74LVC1GX04DCKTG4	SC70	DCK	6	250	180.0	8.4	2.47	2.3	1.25	4.0	8.0	Q3
SN74LVC1GX04DBVR	SOT-23	DBV	6	3000	180.0	8.4	3.23	3.17	1.37	4.0	8.0	Q3
SN74LVC1GX04DBVR	SOT-23	DBV	6	3000	178.0	9.2	3.3	3.23	1.55	4.0	8.0	Q3
SN74LVC1GX04DBVT	SOT-23	DBV	6	250	178.0	9.2	3.3	3.23	1.55	4.0	8.0	Q3
SN74LVC1GX04DBVT	SOT-23	DBV	6	250	180.0	8.4	3.23	3.17	1.37	4.0	8.0	Q3
SN74LVC1GX04DCKR	SC70	DCK	6	3000	180.0	9.2	2.3	2.55	1.2	4.0	8.0	Q3
SN74LVC1GX04DCKR	SC70	DCK	6	3000	178.0	9.2	2.4	2.4	1.22	4.0	8.0	Q3
SN74LVC1GX04DCKR	SC70	DCK	6	3000	178.0	9.0	2.4	2.5	1.2	4.0	8.0	Q3
SN74LVC1GX04DCKT	SC70	DCK	6	250	178.0	9.2	2.4	2.4	1.22	4.0	8.0	Q3
SN74LVC1GX04DCKT	SC70	DCK	6	250	178.0	9.0	2.4	2.5	1.2	4.0	8.0	Q3
SN74LVC1GX04DCKT	SC70	DCK	6	250	180.0	8.4	2.41	2.41	1.2	4.0	8.0	Q3
SN74LVC1GX04DRLR	SOT-5X3	DRL	6	4000	180.0	9.5	1.78	1.78	0.69	4.0	8.0	Q3
SN74LVC1GX04DRLR	SOT-5X3	DRL	6	4000	180.0	8.4	1.98	1.78	0.69	4.0	8.0	Q3

TAPE AND REEL BOX DIMENSIONS

*All dimensions are nominal

Device	Package Type	Package Drawing	Pins	SPQ	Length (mm)	Width (mm)	Height (mm)
74LVC1GX04DCKTG4	SC70	DCK	6	250	183.0	183.0	20.0
SN74LVC1GX04DBVR	SOT-23	DBV	6	3000	202.0	201.0	28.0
SN74LVC1GX04DBVR	SOT-23	DBV	6	3000	180.0	180.0	18.0
SN74LVC1GX04DBVT	SOT-23	DBV	6	250	180.0	180.0	18.0
SN74LVC1GX04DBVT	SOT-23	DBV	6	250	202.0	201.0	28.0
SN74LVC1GX04DCKR	SC70	DCK	6	3000	205.0	200.0	33.0
SN74LVC1GX04DCKR	SC70	DCK	6	3000	180.0	180.0	18.0
SN74LVC1GX04DCKR	SC70	DCK	6	3000	180.0	180.0	18.0
SN74LVC1GX04DCKT	SC70	DCK	6	250	180.0	180.0	18.0
SN74LVC1GX04DCKT	SC70	DCK	6	250	180.0	180.0	18.0
SN74LVC1GX04DCKT	SC70	DCK	6	250	202.0	201.0	28.0
SN74LVC1GX04DRLR	SOT-5X3	DRL	6	4000	184.0	184.0	19.0
SN74LVC1GX04DRLR	SOT-5X3	DRL	6	4000	202.0	201.0	28.0

DBV0006A



PACKAGE OUTLINE

SOT-23 - 1.45 mm max height

SMALL OUTLINE TRANSISTOR



4214840/B 03/2018

NOTES:

1. All linear dimensions are in millimeters. Any dimensions in parenthesis are for reference only. Dimensioning and tolerancing per ASME Y14.5M.
2. This drawing is subject to change without notice.
3. Body dimensions do not include mold flash or protrusion. Mold flash and protrusion shall not exceed 0.15 per side.
4. Leads 1,2,3 may be wider than leads 4,5,6 for package orientation.
5. Reference JEDEC MO-178.

EXAMPLE BOARD LAYOUT

DBV0006A

SOT-23 - 1.45 mm max height

SMALL OUTLINE TRANSISTOR



LAND PATTERN EXAMPLE
EXPOSED METAL SHOWN
SCALE:15X



SOLDER MASK DETAILS

4214840/B 03/2018

NOTES: (continued)

6. Publication IPC-7351 may have alternate designs.

7. Solder mask tolerances between and around signal pads can vary based on board fabrication site.

EXAMPLE STENCIL DESIGN

DBV0006A

SOT-23 - 1.45 mm max height

SMALL OUTLINE TRANSISTOR



SOLDER PASTE EXAMPLE
BASED ON 0.125 mm THICK STENCIL
SCALE:15X

4214840/B 03/2018

NOTES: (continued)

8. Laser cutting apertures with trapezoidal walls and rounded corners may offer better paste release. IPC-7525 may have alternate design recommendations.
9. Board assembly site may have different recommendations for stencil design.

DCK (R-PDSO-G6)

PLASTIC SMALL-OUTLINE PACKAGE

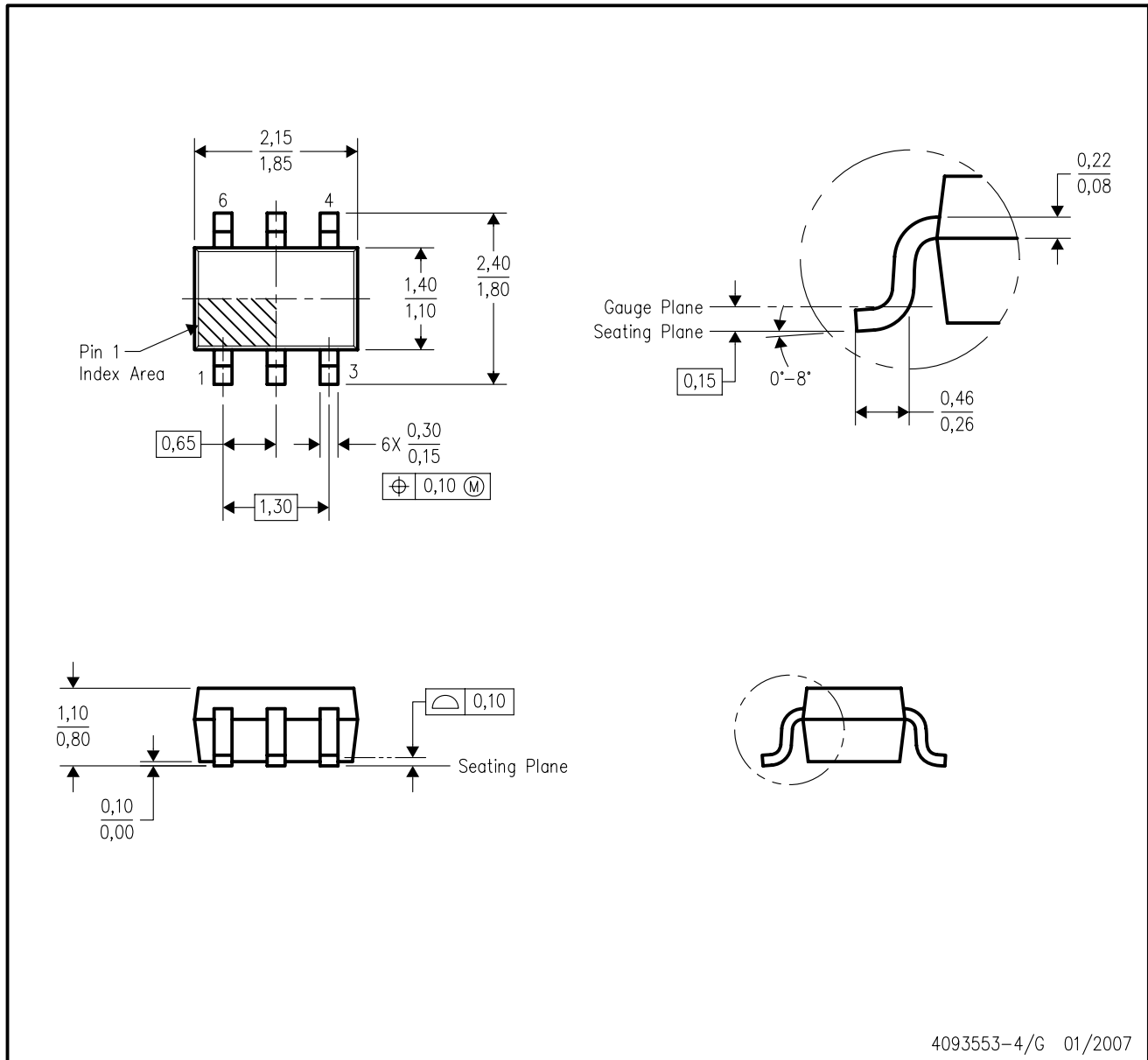

- NOTES:
- A. All linear dimensions are in millimeters.
 - B. This drawing is subject to change without notice.
 - C. Body dimensions do not include mold flash or protrusion. Mold flash and protrusion shall not exceed 0.15 per side.
 - D. Falls within JEDEC MO-203 variation AB.

DCK (R-PDSO-G6)

PLASTIC SMALL OUTLINE

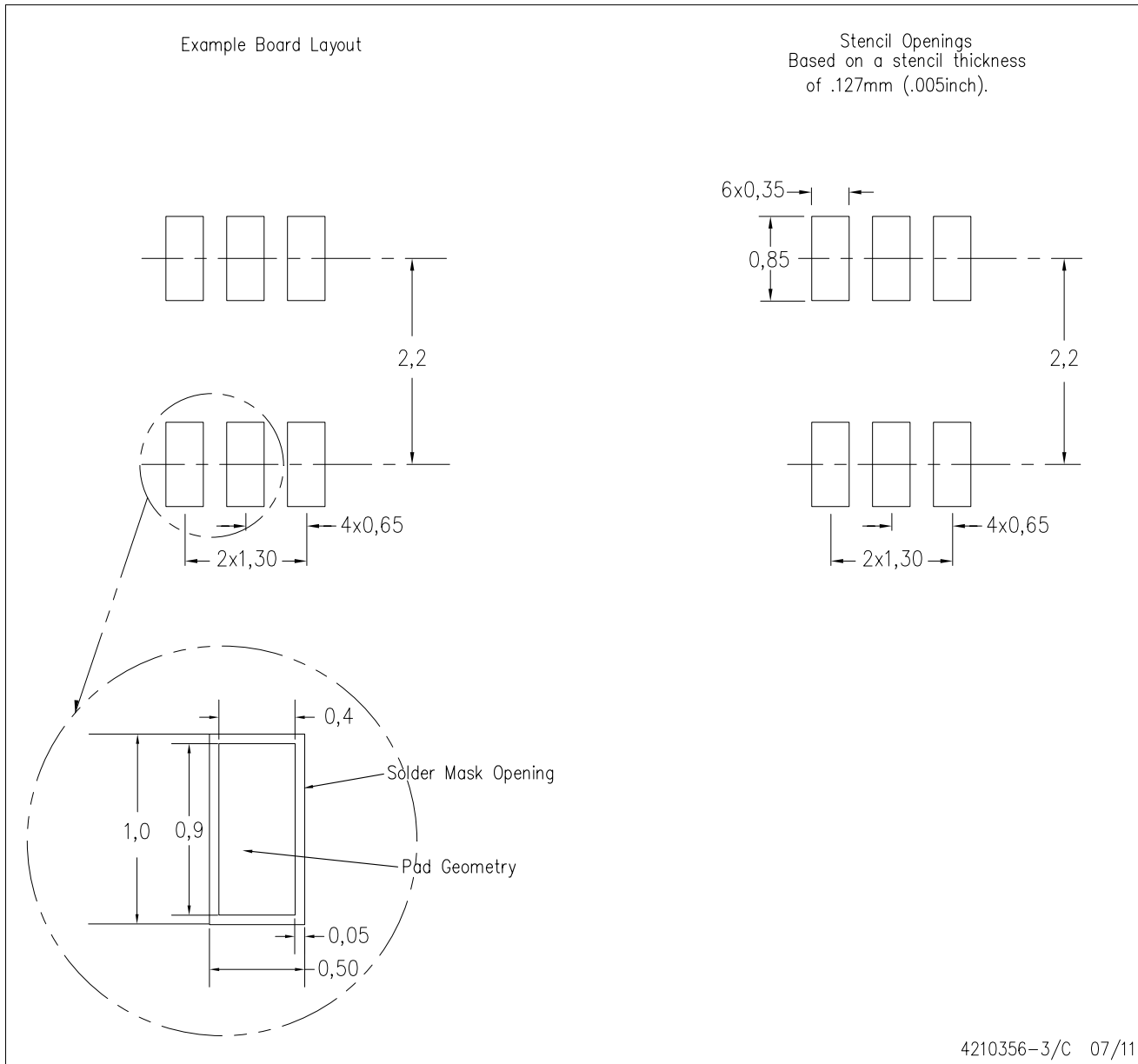

- NOTES:
- All linear dimensions are in millimeters.
 - This drawing is subject to change without notice.
 - Customers should place a note on the circuit board fabrication drawing not to alter the center solder mask defined pad.
 - Publication IPC-7351 is recommended for alternate designs.
 - Laser cutting apertures with trapezoidal walls and also rounding corners will offer better paste release. Customers should contact their board assembly site for stencil design recommendations. Example stencil design based on a 50% volumetric metal load solder paste. Refer to IPC-7525 for other stencil recommendations.

DRL0006A

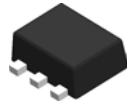

PACKAGE OUTLINE

SOT - 0.6 mm max height

PLASTIC SMALL OUTLINE

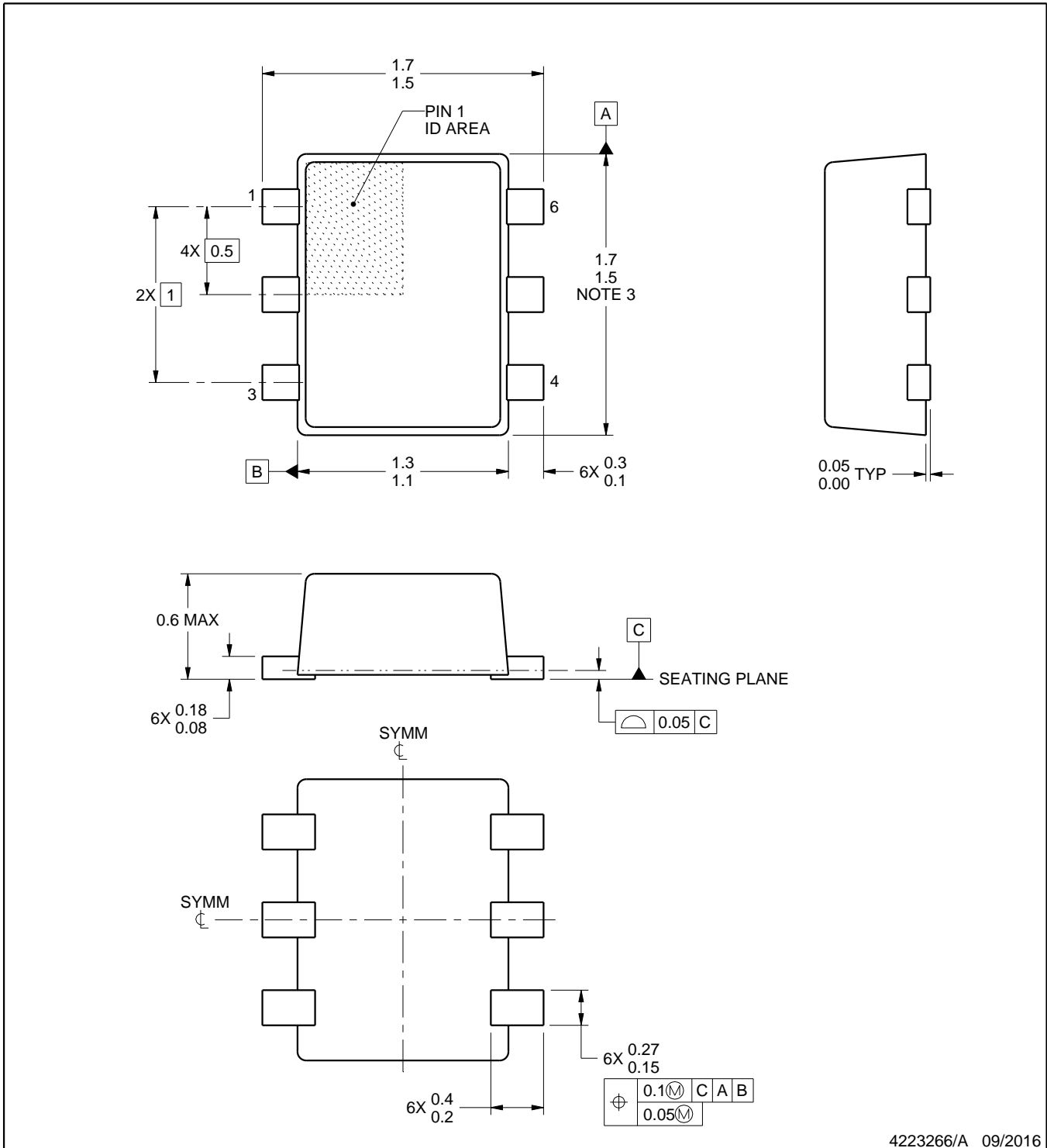

4223266/A 09/2016

NOTES:

1. All linear dimensions are in millimeters. Any dimensions in parenthesis are for reference only. Dimensioning and tolerancing per ASME Y14.5M.
2. This drawing is subject to change without notice.
3. This dimension does not include mold flash, protrusions, or gate burrs. Mold flash, protrusions, or gate burrs shall not exceed 0.15 mm per side.

EXAMPLE BOARD LAYOUT

DRL0006A

SOT - 0.6 mm max height

PLASTIC SMALL OUTLINE

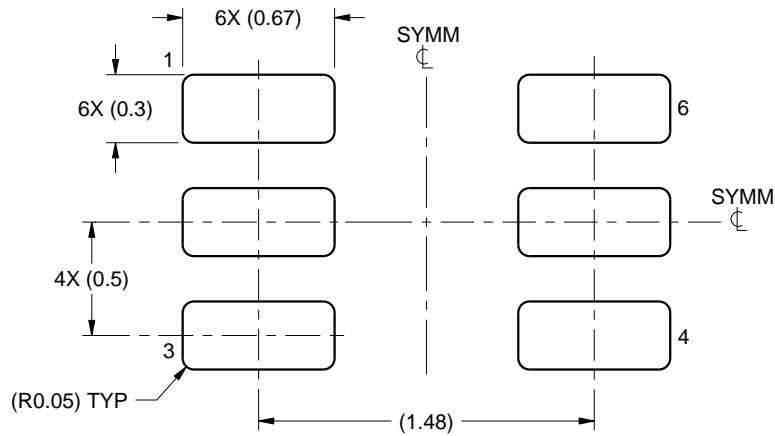

LAND PATTERN EXAMPLE
SCALE:30X

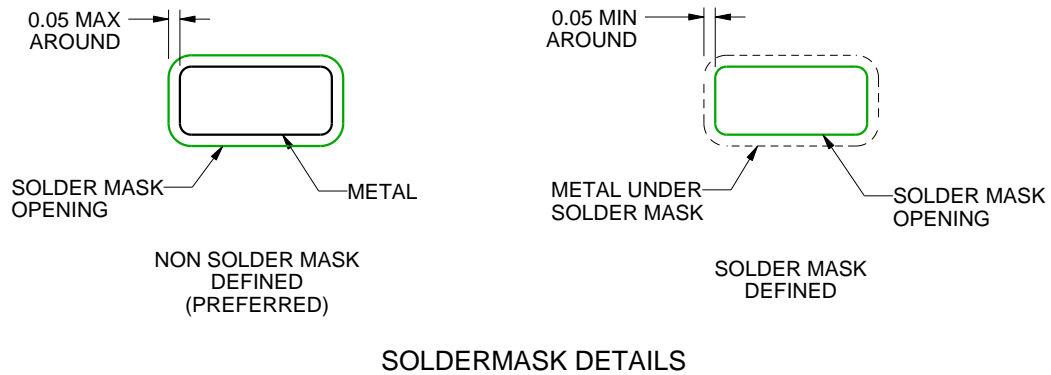

SOLDERMASK DETAILS

4223266/A 09/2016

NOTES: (continued)

- 4. Publication IPC-7351 may have alternate designs.
- 5. Solder mask tolerances between and around signal pads can vary based on board fabrication site.

EXAMPLE STENCIL DESIGN

DRL0006A

SOT - 0.6 mm max height

PLASTIC SMALL OUTLINE

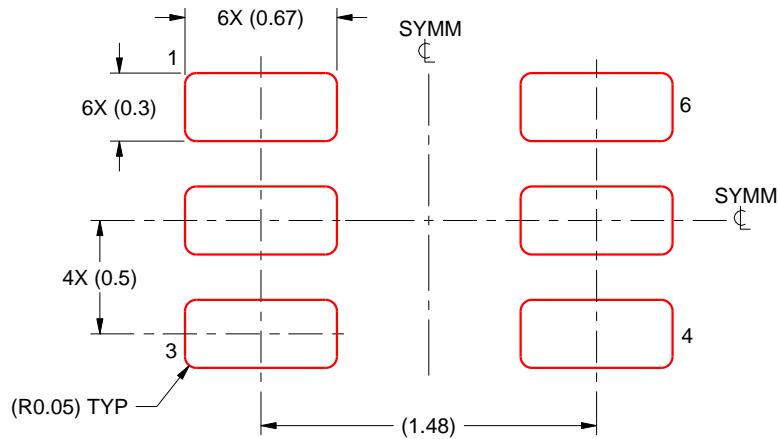

SOLDER PASTE EXAMPLE
BASED ON 0.1 mm THICK STENCIL
SCALE:30X

4223266/A 09/2016

NOTES: (continued)

6. Laser cutting apertures with trapezoidal walls and rounded corners may offer better paste release. IPC-7525 may have alternate design recommendations.
7. Board assembly site may have different recommendations for stencil design.

IMPORTANT NOTICE AND DISCLAIMER

TI PROVIDES TECHNICAL AND RELIABILITY DATA (INCLUDING DATASHEETS), DESIGN RESOURCES (INCLUDING REFERENCE DESIGNS), APPLICATION OR OTHER DESIGN ADVICE, WEB TOOLS, SAFETY INFORMATION, AND OTHER RESOURCES "AS IS" AND WITH ALL FAULTS, AND DISCLAIMS ALL WARRANTIES, EXPRESS AND IMPLIED, INCLUDING WITHOUT LIMITATION ANY IMPLIED WARRANTIES OF MERCHANTABILITY, FITNESS FOR A PARTICULAR PURPOSE OR NON-INFRINGEMENT OF THIRD PARTY INTELLECTUAL PROPERTY RIGHTS.

These resources are intended for skilled developers designing with TI products. You are solely responsible for (1) selecting the appropriate TI products for your application, (2) designing, validating and testing your application, and (3) ensuring your application meets applicable standards, and any other safety, security, or other requirements. These resources are subject to change without notice. TI grants you permission to use these resources only for development of an application that uses the TI products described in the resource. Other reproduction and display of these resources is prohibited. No license is granted to any other TI intellectual property right or to any third party intellectual property right. TI disclaims responsibility for, and you will fully indemnify TI and its representatives against, any claims, damages, costs, losses, and liabilities arising out of your use of these resources.

TI's products are provided subject to TI's Terms of Sale (www.ti.com/legal/termsofsale.html) or other applicable terms available either on ti.com or provided in conjunction with such TI products. TI's provision of these resources does not expand or otherwise alter TI's applicable warranties or warranty disclaimers for TI products.

Mailing Address: Texas Instruments, Post Office Box 655303, Dallas, Texas 75265
Copyright © 2019, Texas Instruments Incorporated

Looking for pricing, stock, or lifecycle information?

Click below to explore more details on WIN SOURCE:

 [View SN74LVC1GX04DRLR on WIN SOURCE](#)

 [Texas Instruments](#) Information

Optimize Your Supply Chain with WIN SOURCE Solutions

-  Global Sourcing Solution
-  Obsolete Management
-  Cost Control Management
-  Shortage Management
-  Alternative Solution
-  Excess Inventory Management