



**THE DATASHEET OF
BQ24095DGQT**



bq2409x 1A, Single-Input, Single Cell Li-Ion and Li-Pol Battery Charger

1 Features

- Charging
 - 1% Charge Voltage Accuracy
 - 10% Charge Current Accuracy
 - Pin Selectable USB 100-mA and 500-mA Maximum Input Current Limit
 - Programmable Termination and Precharge Threshold
- Protection
 - 6.6 V Over-Voltage Protection
 - Input Voltage Dynamic Power Management
 - 125°C Thermal Regulation; 150°C Thermal Shutdown Protection
 - OUT Short-Circuit Protection and ISET Short Detection
 - Operation Over JEITA Range via Battery NTC – ½ Fast-Charge-Current at Cold, 4.06V at Hot, bq24092/3
 - Fixed 10-Hour Safety Timer
- System
 - Automatic Termination and Timer Disable Mode (TTDM) for Absent Battery Pack With Thermistor
 - Status Indication – Charging/Done
 - Available in Small 10-Pin MSOP Package

2 Applications

- Smart Phones
- PDAs
- MP3 Players
- Low-Power Handheld Devices

3 Description

The bq2409x series of devices are highly integrated Li-ion and Li-Pol linear chargers devices targeted at space-limited portable applications. The devices operate from either a USB port or AC adaptor. The high input voltage range with input overvoltage protection supports low-cost unregulated adapters.

The bq2409x has a single power output that charges the battery. A system load can be placed in parallel with the battery as long as the average system load does not keep the battery from charging fully during the 10-hour safety timer.

The battery is charged in three phases: conditioning, constant current and constant voltage. In all charge phases, an internal control loop monitors the IC junction temperature and reduces the charge current if an internal temperature threshold is exceeded.

Device Information⁽¹⁾

PART NUMBER	PACKAGE	BODY SIZE (NOM)
bq2409x	HVSSOP (10)	3.00 mm x 3.00 mm

(1) For all available packages, see the orderable addendum at the end of the datasheet.

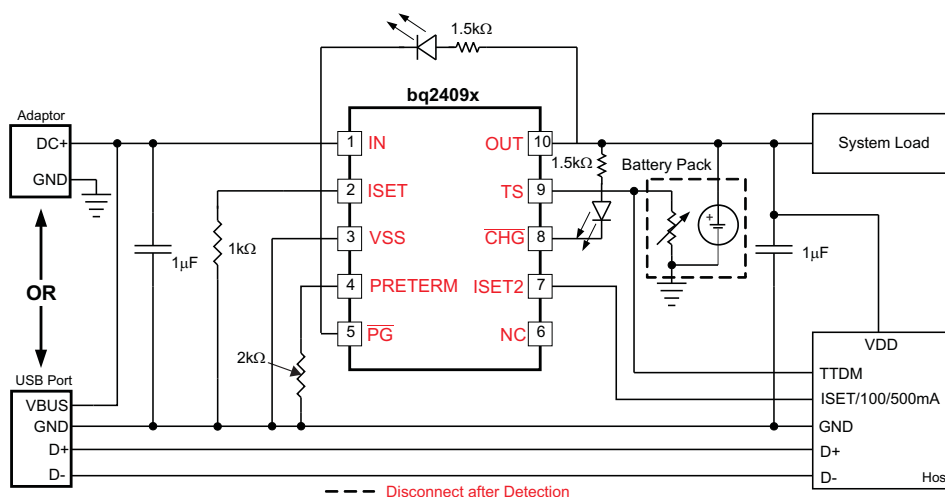

Table of Contents

1 Features	1	9.3 Feature Description.....	16
2 Applications	1	9.4 Device Functional Modes.....	22
3 Description	1	10 Application and Implementation	25
4 Revision History	2	10.1 Application Information.....	25
5 Description (continued)	4	10.2 Typical Application	25
6 Device Options	4	11 Power Supply Recommendations	28
7 Pin Configuration and Functions	4	12 Layout	28
8 Specifications	5	12.1 Layout Guidelines	28
8.1 Absolute Maximum Ratings	5	12.2 Layout Example	28
8.2 ESD Ratings.....	5	12.3 Thermal Considerations.....	29
8.3 Recommended Operating Conditions	6	13 Device and Documentation Support	30
8.4 Thermal Information	6	13.1 Device Support.....	30
8.5 Dissipation Ratings	6	13.2 Related Links	30
8.6 Electrical Characteristics.....	6	13.3 Trademarks	30
8.7 Typical Characteristics	10	13.4 Electrostatic Discharge Caution.....	30
9 Detailed Description	13	13.5 Glossary	30
9.1 Overview	13	14 Mechanical, Packaging, and Orderable Information	30
9.2 Functional Block Diagram	15		

4 Revision History

Changes from Revision F (December 2014) to Revision G	Page
• Changed bq24095 $V_{O(REG)}$ value From: 4.20 V To: 4.35 V in the <i>Device Options</i> table	4

Changes from Revision E (September 2013) to Revision F	Page
• Added <i>ESD Ratings</i> table, <i>Feature Description</i> section, <i>Device Functional Modes</i> , <i>Application and Implementation</i> section, <i>Power Supply Recommendations</i> section, <i>Layout</i> section, <i>Device and Documentation Support</i> section, and <i>Mechanical, Packaging, and Orderable Information</i> section	1

Changes from Revision D (December 2012) to Revision E	Page
• Deleted the MARKING column from the ORDERING INFORMATION table, and added table note 1.....	4

Changes from Revision C (May 2012) to Revision D	Page
• Added bq24095 to the ORDERING INFORMATION table.....	4
• Changed bq24090/2 to bq24090/2/5 for TS pin description in Pin Functions table.....	5
• Changed the K_{ISET} entry in the Elect Characteristics table	7
• Deleted "Line Regulation" typical characteristics graph	11
• Changed "Current Regulation Over Temperature" graph to "Load Regulation - bq24095" graph.....	11

Changes from Revision B (June 2010) to Revision C	Page
• Changed all instances of Li-ion To: Li-ion and Li-Pol.....	1

Changes from Revision A (February 2010) to Revision B**Page**

- Changed the device number on the front page circuit From: bq24090 To: bq2409x 1
 - Changed the ORDERING INFORMATION table Marking column From: Product Preview To: bq24092 and bq24093..... 4
-

Changes from Original (January 2010) to Revision A**Page**

- Changed $V_{DO(IN-OUT)}$, MAX value From: 500 mV To: 520 mV in the Elect Characteristics table 7
 - Changed $I_{PRE-TERM}$ MAX value From: 79 μ A to 81 μ A in the Elect Characteristics table 8
 - Changed $V_{CLAMP(TS)}$ MIN value From: 1900 mV to 1800 mV in the Elect Characteristics table 9
-

5 Description (continued)

The charger power stage and charge current sense functions are fully integrated. The charger function has high accuracy current and voltage regulation loops, charge status display, and charge termination. The pre-charge current and termination current threshold are programmed via an external resistor. The fast charge current value is also programmable via an external resistor.

6 Device Options

PART NUMBER	V _{O(REG)}	V _{OVP}	JEITA	TS/CE	PG	PACKAGE
bq24090	4.20 V	6.6 V	No	10 kΩ NTC	Yes	10 PIN 5x3mm ²
bq24091	4.20 V	6.6 V	No	100 kΩ NTC	Yes	10 PIN 5x3mm ²
bq24092	4.20 V	6.6 V	Yes	10 kΩ NTC	Yes	10 PIN 5x3mm ²
bq24093	4.20 V	6.6 V	Yes	100 kΩ NTC	Yes	10 PIN 5x3mm ²
bq24095	4.35 V	6.6 V	No	10 kΩ NTC	Yes	10 PIN 5x3mm ²

7 Pin Configuration and Functions

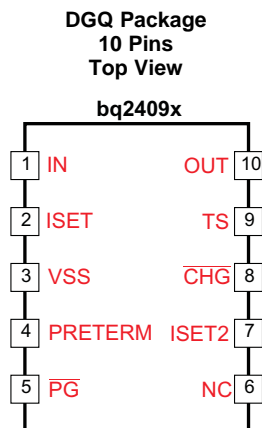

Pin Functions

PIN		I/O	DESCRIPTION
NAME	NO.		
$\overline{\text{CHG}}$	8	O	Low (FET on) indicates charging and Open Drain (FET off) indicates no Charging or Charge complete.
IN	1	I	Input power, connected to external DC supply (AC adapter or USB port). Expected range of bypass capacitors 1μF to 10μF, connect from IN to V _{SS} .
ISET	2	I	Programs the Fast-charge current setting. External resistor from ISET to V _{SS} defines fast charge current value. Range is 10.8k (50mA) to 540 Ω (1000mA).
ISET2	7	I	Programming the Input/Output Current Limit for the USB or Adaptor source: High = 500mAmax, Low = ISET, FLOAT = 100mA max.
NC	6	NA	Do not make a connection to this pin (for internal use) – Do not route through this pin
OUT	10	O	Battery Connection. System Load may be connected. Average load should not be excessive, allowing battery to charge within the 10 hour safety timer window. Expected range of bypass capacitors 1μF to 10μF.
$\overline{\text{PG}}$	5	O	Low (FET on) indicates the input voltage is above UVLO and the OUT (battery) voltage.
PRE-TERM	4	I	Programs the Current Termination Threshold (5 to 50% of I _{out} which is set by ISET) and Sets the Pre-Charge Current to twice the Termination Current Level. Expected range of programming resistor is 1k to 10kΩ (2k: I _{pgm} /10 for term; I _{pgm} /5 for precharge)

Pin Functions (continued)

PIN		I/O	DESCRIPTION
NAME	NO.		
Thermal PAD and Package	—	—	There is an internal electrical connection between the exposed thermal pad and the VSS pin of the device. The thermal pad must be connected to the same potential as the VSS pin on the printed circuit board. Do not use the thermal pad as the primary ground input for the device. VSS pin must be connected to ground at all times
TS	9	I	Temperature sense pin connected to bq24090/2/5 -10k at 25°C NTC thermistor & bq24091/3 -100k at 25°C NTC thermistor, in the battery pack. Floating TS Pin or pulling High puts part in TTDM "Charger" Mode and disable TS monitoring, Timers and Termination. Pulling pin Low disables the IC. If NTC sensing is not needed, connect this pin to VSS through an external 10 kΩ/100kΩ resistor. A 250kΩ from TS to ground will prevent IC entering TTDM mode when battery with thermistor is removed.
VSS	3	—	Ground terminal

8 Specifications

8.1 Absolute Maximum Ratings⁽¹⁾

over operating free-air temperature (unless otherwise noted)

		MIN	MAX	UNIT
Input Voltage ⁽²⁾	IN (with respect to VSS)	-0.3	12	V
	OUT (with respect to VSS)	-0.3	7	V
	PRE-TERM, ISET, ISET2, TS, $\overline{\text{CHG}}$, $\overline{\text{PG}}$, ASI, ASO (with respect to VSS)	-0.3	7	V
Input Current	IN		1.25	A
Output Current (Continuous)	OUT		1.25	A
Output Sink Current	$\overline{\text{CHG}}$		15	mA
Junction temperature, T _J		-40	150	°C
Storage temperature, T _{stg}		-65	150	°C

- (1) Stresses beyond those listed under *Absolute Maximum Ratings* may cause permanent damage to the device. These are stress ratings only, and functional operation of the device at these or any other conditions beyond those indicated under *Recommended Operating Conditions* is not implied. Exposure to absolute-maximum-rated conditions for extended periods may affect device reliability.
- (2) All voltage values are with respect to the network ground terminal unless otherwise noted.

8.2 ESD Ratings

		VALUE	UNIT
V _(ESD) Electrostatic discharge	Human-body model (HBM), per ANSI/ESDA/JEDEC JS-001 ⁽¹⁾	±3000	V
	Charged-device model (CDM), per JEDEC specification JESD22-C101 ⁽²⁾	±1500	

- (1) JEDEC document JEP155 states that 500-V HBM allows safe manufacturing with a standard ESD control process.
- (2) JEDEC document JEP157 states that 250-V CDM allows safe manufacturing with a standard ESD control process.

8.3 Recommended Operating Conditions⁽¹⁾

		MIN	MAX	UNIT
V _{IN}	IN voltage range	3.5	12	V
	IN operating voltage range, Restricted by V _{DPM} and V _{OVP}	4.45	6.45	V
I _{IN}	Input current, IN pin		1.0	A
I _{OUT}	Current, OUT pin		1.0	A
T _J	Junction temperature	0	125	°C
R _{PRE-TERM}	Programs precharge and termination current thresholds	1	10	kΩ
R _{ISSET}	Fast-charge current programming resistor	0.540	49.9	kΩ
R _{TS}	10kΩ NTC thermistor range without entering BAT_EN or TTDM	1.66	258	kΩ

(1) Operation with V_{IN} less than 4.5V or in drop-out may result in reduced performance.

8.4 Thermal Information

THERMAL METRIC ⁽¹⁾		bq2409x	UNIT
		DGQ	
		10 PINS	
R _{θJA}	Junction-to-ambient thermal resistance	71.2	°C/W
R _{θJC(top)}	Junction-to-case (top) thermal resistance	53.9	
R _{θJB}	Junction-to-board thermal resistance	45.2	
Ψ _{JT}	Junction-to-top characterization parameter	3.5	
Ψ _{JB}	Junction-to-board characterization parameter	44.9	
R _{θJC(bot)}	Junction-to-case (bottom) thermal resistance	19.2	

(1) For more information about traditional and new thermal metrics, see the *IC Package Thermal Metrics* application report, [SPRA953](#).

8.5 Dissipation Ratings^{(1) (2)}

PACKAGE	R _{θJA}	R _{θJC}	T _A ≤ 25°C POWER RATING	DERATING FACTOR T _A > 25°C
5x3mm MSOP	52°C/W	48°C/W	1.92 W	19.2 mW/°C

(1) For the most current package and ordering information, see the Package Option Addendum at the end of this document, or see the TI website at [www.ti.com](#).

(2) This data is based on using the JEDEC High-K board and the exposed die pad is connected to a copper pad on the board. This is connected to the ground plane by a 2x3 via matrix

8.6 Electrical Characteristics

over junction temperature range 0°C ≤ T_J ≤ 125°C and recommended supply voltage (unless otherwise noted)

PARAMETER		TEST CONDITIONS	MIN	TYP	MAX	UNIT
INPUT						
UVLO	Undervoltage lock-out Exit	V _{IN} : 0V → 4V Update based on sim/char	3.15	3.3	3.45	V
V _{HYS_UVLO}	Hysteresis on V _{UVLO_RISE} falling	V _{IN} : 4V→0V, V _{UVLO_FALL} = V _{UVLO_RISE} -V _{HYS_UVLO}	175	227	280	mV
V _{IN-DT}	Input power good detection threshold is V _{OUT} + V _{IN-DT}	(Input power good if V _{IN} > V _{OUT} + V _{IN-DT}); V _{OUT} = 3.6V, V _{IN} : 3.5V → 4V	30	80	145	mV
V _{HYS-INDT}	Hysteresis on V _{IN-DT} falling	V _{OUT} = 3.6V, V _{IN} : 4V → 3.5V		31		mV
t _{DGL(PG_PWR)}	Deglint time on exiting sleep.	Time measured from V _{IN} : 0V → 5V 1μs rise-time to PG = low, V _{OUT} = 3.6V		45		μs
t _{DGL(PG_NO-PWR)}	Deglint time on V _{HYS-INDT} power down. Same as entering sleep.	Time measured from V _{IN} : 5V → 3.2V 1μs fall-time to PG = OC, V _{OUT} = 3.6V		29		ms
V _{OVP}	Input over-voltage protection threshold	V _{IN} : 5V → 7V	6.5	6.65	6.8	V
t _{DGL(OVP-SET)}	Input over-voltage blanking time	V _{IN} : 5V → 7V		113		μs
V _{HYS-OVP}	Hysteresis on OVP	V _{IN} : 7V → 5V		95		mV
t _{DGL(OVP-REC)}	Deglint time exiting OVP	Time measured from V _{IN} : 7V → 5V 1μs fall-time to PG = LO		30		μs

Electrical Characteristics (continued)

over junction temperature range $0^{\circ}\text{C} \leq T_J \leq 125^{\circ}\text{C}$ and recommended supply voltage (unless otherwise noted)

PARAMETER		TEST CONDITIONS	MIN	TYP	MAX	UNIT
V_{IN-DPM}	USB/Adaptor low input voltage protection. Restricts I _{OUT} at V_{IN-DPM}	Feature active in USB mode; Limit Input Source Current to 50mA; $V_{OUT} = 3.5\text{V}$; $R_{ISET} = 825\Omega$	4.34	4.4	4.46	V
		Feature active in Adaptor mode; Limit Input Source Current to 50mA; $V_{OUT} = 3.5\text{V}$; $R_{ISET} = 825\Omega$	4.24	4.3	4.36	
$I_{IN-USB-CL}$	USB input I-Limit 100mA	$ISET2 = \text{Float}$; $R_{ISET} = 825\Omega$	85	92	100	mA
	USB input I-Limit 500mA	$ISET2 = \text{High}$; $R_{ISET} = 825\Omega$	430	462	500	
ISET SHORT CIRCUIT TEST						
R_{ISET_SHORT}	Highest Resistor value considered a fault (short). Monitored for I _{OUT} >90mA	Riset: $600\Omega \rightarrow 250\Omega$, I _{OUT} latches off. Cycle power to Reset.	280		500	Ω
t_{DGL_SHORT}	Deglitch time transition from ISET short to I _{OUT} disable	Clear fault by cycling IN or TS/ $\overline{\text{BAT_EN}}$		1		ms
I_{OUT_CL}	Maximum OUT current limit Regulation (Clamp)	$V_{IN} = 5\text{V}$, $V_{OUT} = 3.6\text{V}$, $V_{ISET2} = \text{Low}$, R_{ISET} : $600\Omega \rightarrow 250\Omega$, I _{OUT} latches off after t_{DGL_SHORT}	1.05		1.4	A
BATTERY SHORT PROTECTION						
$V_{OUT(SC)}$	OUT pin short-circuit detection threshold/ precharge threshold	$V_{OUT}: 3\text{V} \rightarrow 0.5\text{V}$, no deglitch	0.75	0.8	0.85	V
$V_{OUT(SC-HYS)}$	OUT pin Short hysteresis	Recovery $\geq V_{OUT(SC)} + V_{OUT(SC-HYS)}$; Rising, no Deglitch		77		mV
$I_{OUT(SC)}$	Source current to OUT pin during short-circuit detection		10	15	20	mA
QUIESCENT CURRENT						
$I_{OUT(PDWN)}$	Battery current into OUT pin	$V_{IN} = 0\text{V}$			1	μA
$I_{OUT(DONE)}$	OUT pin current, charging terminated	$V_{IN} = 6\text{V}$, $V_{OUT} > V_{OUT(REG)}$			6	
$I_{IN(STDBY)}$	Standby current into IN pin	$TS = \text{LO}$, $V_{IN} \leq 6\text{V}$			125	μA
I_{CC}	Active supply current, IN pin	$TS = \text{open}$, $V_{IN} = 6\text{V}$, TTDM – no load on OUT pin, $V_{OUT} > V_{OUT(REG)}$, IC enabled		0.8	1.0	mA
BATTERY CHARGER FAST-CHARGE						
$V_{OUT(REG)}$	Battery regulation voltage (bq24090/1/2/3)	$V_{IN} = 5.5\text{V}$, $I_{OUT} = 25\text{mA}$, ($V_{TS-45^{\circ}\text{C}} \leq V_{TS} \leq V_{TS-0^{\circ}\text{C}}$)	4.16	4.2	4.23	V
	Battery regulation voltage (bq24095)	$V_{IN} = 5.5\text{V}$, $I_{OUT} = 25\text{mA}$	4.30	4.35	4.40	
$V_{O_HT(REG)}$	Battery hot regulation Voltage, bq24092/3	$V_{IN} = 5.5\text{V}$, $I_{OUT} = 25\text{mA}$, $V_{TS-60^{\circ}\text{C}} \leq V_{TS} \leq V_{TS-45^{\circ}\text{C}}$	4.02	4.06	4.1	V
$I_{OUT(RANGE)}$	Programmed Output "fast charge" current range	$V_{OUT(REG)} > V_{OUT} > V_{LOWV}$; $V_{IN} = 5\text{V}$, $ISET2 = \text{Lo}$, $R_{ISET} = 540$ to $10.8\text{k}\Omega$	10		1000	mA
$V_{DO(IN-OUT)}$	Drop-Out, $V_{IN} - V_{OUT}$	Adjust V_{IN} down until $I_{OUT} = 0.5\text{A}$, $V_{OUT} = 4.15\text{V}$, $R_{ISET} = 540$, $ISET2 = \text{Lo}$ (adaptor mode); $T_J \leq 100^{\circ}\text{C}$		325	520	mV
I_{OUT}	Output "fast charge" formula	$V_{OUT(REG)} > V_{OUT} > V_{LOWV}$; $V_{IN} = 5\text{V}$, $ISET2 = \text{Lo}$		K_{ISET}/R_{ISET}		A
K_{ISET}	Fast charge current factor for bq24090, 91, 92, 93	$R_{ISET} = K_{ISET}/I_{OUT}$; $50 < I_{OUT} < 1000$ mA	510	540	565	A Ω
		$R_{ISET} = K_{ISET}/I_{OUT}$; $25 < I_{OUT} < 50$ mA	480	527	580	
		$R_{ISET} = K_{ISET}/I_{OUT}$; $10 < I_{OUT} < 25$ mA	350	520	680	
K_{ISET}	Fast charge current factor for bq24095	$R_{ISET} = K_{ISET}/I_{OUT}$; $50 < I_{OUT} < 1000$ mA	510	560	585	A Ω
		$R_{ISET} = K_{ISET}/I_{OUT}$; $25 < I_{OUT} < 50$ mA	480	557	596	
		$R_{ISET} = K_{ISET}/I_{OUT}$; $10 < I_{OUT} < 25$ mA	350	555	680	
PRECHARGE – SET BY PRETERM PIN						
V_{LOWV}	Pre-charge to fast-charge transition threshold		2.4	2.5	2.6	V
$t_{DGL1(LOWV)}$	Deglitch time on pre-charge to fast-charge transition			70		μs
$t_{DGL2(LOWV)}$	Deglitch time on fast-charge to pre-charge transition			32		ms
$I_{PRE-TERM}$	Refer to the Termination Section					
%PRECHG	Pre-charge current, default setting	$V_{OUT} < V_{LOWV}$; $R_{ISET} = 1080\Omega$; R_{PRE-TERM} = High Z	18	20	22	%I _{OUT-CC}
	Pre-charge current formula	$R_{PRE-TERM} = K_{PRE-CHG} (\Omega/\%) \times \%PRE-CHG (\%)$		$R_{PRE-TERM}/K_{PRE-CHG}\%$		

Electrical Characteristics (continued)

over junction temperature range $0^{\circ}\text{C} \leq T_J \leq 125^{\circ}\text{C}$ and recommended supply voltage (unless otherwise noted)

PARAMETER		TEST CONDITIONS	MIN	TYP	MAX	UNIT
K _{PRE-CHG}	% Pre-charge Factor	$V_{OUT} < V_{LOWV}$, $V_{IN} = 5V$, $R_{PRE-TERM} = 2k$ to $10k\Omega$; $R_{ISET} = 1080\Omega$, $R_{PRE-TERM} = K_{PRE-CHG} \times \%I_{FAST-CHG}$, where $\%I_{FAST-CHG}$ is 20 to 100%	90	100	110	$\Omega/\%$
		$V_{OUT} < V_{LOWV}$, $V_{IN} = 5V$, $R_{PRE-TERM} = 1k$ to $2k\Omega$; $R_{ISET} = 1080\Omega$, $R_{PRE-TERM} = K_{PRE-CHG} \times \%I_{FAST-CHG}$, where $\%I_{FAST-CHG}$ is 10% to 20%	84	100	117	$\Omega/\%$
TERMINATION – SET BY PRE-TERM PIN						
% _{TERM}	Termination Threshold Current, default setting	$V_{OUT} > V_{RCH}$; $R_{ISET} = 1k$; R_{PRE-TERM} = High Z	9	10	11	$\%I_{OUT-CC}$
	Termination Current Threshold Formula	$R_{PRE-TERM} = K_{TERM} (\Omega/\%) \times \%TERM (\%)$	$R_{PRE-TERM} / K_{TERM}$			
K _{TERM}	% Term Factor	$V_{OUT} > V_{RCH}$, $V_{IN} = 5V$, $R_{PRE-TERM} = 2k$ to $10k\Omega$; $R_{ISET} = 750\Omega$ $K_{TERM} \times \%I_{FAST-CHG}$, where $\%I_{FAST-CHG}$ is 10 to 50%	182	200	216	$\Omega/\%$
		$V_{OUT} > V_{RCH}$, $V_{IN} = 5V$, $R_{PRE-TERM} = 1k$ to $2k\Omega$; $R_{ISET} = 750\Omega$ $K_{TERM} \times \%I_{set}$, where $\%I_{set}$ is 5 to 10%	174	199	224	
I _{PRE-TERM}	Current for programming the term. and pre-chg with resistor. I _{Term-Start} is the initial PRE-TERM current.	$R_{PRE-TERM} = 2k$, $V_{OUT} = 4.15V$	71	75	81	μA
% _{TERM}	Termination current formula		$R_{TERM} / K_{TERM} \%$			
t _{DGL(TERM)}	Deglitch time, termination detected		29			ms
I _{Term-Start}	Elevated PRE-TERM current for, t _{Term-Start} during start of charge to prevent recharge of full battery,		80	85	92	μA
t _{Term-Start}	Elevated termination threshold initially active for t _{Term-Start}		1.25			min
RECHARGE OR REFRESH						
V _{RCH}	Recharge detection threshold – Normal Temp	$V_{IN} = 5V$, $V_{TS} = 0.5V$, $V_{OUT}: 4.25V \rightarrow V_{RCH}$	$V_{O(REG)} - 0.120$	$V_{O(REG)} - 0.095$	$V_{O(REG)} - 0.070$	V
	Recharge detection threshold – Hot Temp	$V_{IN} = 5V$, $V_{TS} = 0.2V$, $V_{OUT}: 4.15V \rightarrow V_{RCH}$	$V_{O(REG)} - 0.130$	$V_{O(REG)} - 0.105$	$V_{O(REG)} - 0.080$	V
t _{DGL1(RCH)}	Deglitch time, recharge threshold detected	$V_{IN} = 5V$, $V_{TS} = 0.5V$, $V_{OUT}: 4.25V \rightarrow 3.5V$ in 1 μs ; t _{DGL(RCH)} is time to ISET ramp	29			ms
t _{DGL2(RCH)}	Deglitch time, recharge threshold detected in OUT-Detect Mode	$V_{IN} = 5V$, $V_{TS} = 0.5V$, $V_{OUT} = 3.5V$ inserted; t _{DGL(RCH)} is time to ISET ramp	3.6			ms
BATTERY DETECT ROUTINE						
V _{REG-BD}	V _{OUT} Reduced regulation during battery detect		$V_{O(REG)} - 0.450$	$V_{O(REG)} - 0.400$	$V_{O(REG)} - 0.350$	V
I _{BD-SINK}	Sink current during V _{REG-BD}	$V_{IN} = 5V$, $V_{TS} = 0.5V$, Battery Absent	7			10 mA
t _{DGL(HI/LOW REG)}	Regulation time at V _{REG} or V _{REG-BD}		25			ms
V _{BD-HI}	High battery detection threshold	$V_{IN} = 5V$, $V_{TS} = 0.5V$, Battery Absent	$V_{O(REG)} - 0.150$	$V_{O(REG)} - 0.100$	$V_{O(REG)} - 0.050$	V
V _{BD-LO}	Low battery detection threshold	$V_{IN} = 5V$, $V_{TS} = 0.5V$, Battery Absent	$V_{REG-BD} + 0.50$	$V_{REG-BD} + 0.1$	$V_{REG-BD} + 0.15$	V
BATTERY CHARGING TIMERS AND FAULT TIMERS						
t _{PRECHG}	Pre-charge safety timer value	Restarts when entering Pre-charge; Always enabled when in pre-charge.	1700	1940	2250	s
t _{MAXCH}	Charge safety timer value	Clears fault or resets at UVLO, TS/BAT_EN disable, OUT Short, exiting LOWV and Refresh	34000	38800	45000	s
BATTERY-PACK NTC MONITOR (Note 1); TS pin: 10k and 100k NTC						
I _{NTC-10k}	NTC bias current, bq24090/2/5	$V_{TS} = 0.3V$	48	50	52	μA
I _{NTC-100k}	NTC bias current, bq24091/3	$V_{TS} = 0.3V$	4.8	5.0	5.2	μA
I _{NTC-DIS-10k}	10k NTC bias current when Charging is disabled, bq24090/2/5	$V_{TS} = 0V$	27	30	34	μA
I _{NTC-DIS-100k}	100k NTC bias current when Charging is disabled, bq24091/3	$V_{TS} = 0V$	4.4	5.0	5.8	μA

Electrical Characteristics (continued)

 over junction temperature range $0^{\circ}\text{C} \leq T_J \leq 125^{\circ}\text{C}$ and recommended supply voltage (unless otherwise noted)

PARAMETER		TEST CONDITIONS	MIN	TYP	MAX	UNIT
$I_{\text{INTC-FLDBK-10k}}$	INTC is reduced prior to entering TTDM to keep cold thermistor from entering TTDM, bq24090/2/5	V_{TS} : Set to 1.525V	4	5	6.5	μA
$I_{\text{INTC-FLDBK-100k}}$	INTC is reduced prior to entering TTDM to keep cold thermistor from entering TTDM, bq24091/3	V_{TS} : Set to 1.525V	1.1	1.5	1.9	μA
$V_{\text{TTDM(TS)}}$	Termination and timer disable mode Threshold – Enter	V_{TS} : 0.5V \rightarrow 1.7V; Timer Held in Reset	1550	1600	1650	mV
$V_{\text{HYS-TTDM(TS)}}$	Hysteresis exiting TTDM	V_{TS} : 1.7V \rightarrow 0.5V; Timer Enabled		100		mV
$V_{\text{CLAMP(TS)}}$	TS maximum voltage clamp	V_{TS} = Open (Float)	1800	1950	2000	mV
$t_{\text{DGL(TTDM)}}$	Deglitch exit TTDM between states			57		ms
	Deglitch enter TTDM between states			8		μs
$V_{\text{TS-I-FLDBK}}$	TS voltage where INTC is reduce to keep thermistor from entering TTDM	INTC adjustment (90 to 10%; 45 to 6.6 μs) takes place near this spec threshold. V_{TS} : 1.425V \rightarrow 1.525V		1475		mV
C_{TS}	Optional Capacitance – ESD			0.22		μF
$V_{\text{TS-0}^{\circ}\text{C}}$	Low temperature CHG Pending	Low Temp Charging to Pending; V_{TS} : 1.0V \rightarrow 1.5V	1205	1230	1255	mV
$V_{\text{HYS-0}^{\circ}\text{C}}$	Hysteresis at 0°C	Charge pending to low temp charging; V_{TS} : 1.5V \rightarrow 1V		86		mV
$V_{\text{TS-10}^{\circ}\text{C}}$	Low temperature, half charge, bq24092/3	Normal charging to low temp charging; V_{TS} : 0.5V \rightarrow 1V	765	790	815	mV
$V_{\text{HYS-10}^{\circ}\text{C}}$	Hysteresis at 10°C, bq24092/3	Low temp charging to normal CHG; V_{TS} : 1.0V \rightarrow 0.5V		35		mV
$V_{\text{TS-45}^{\circ}\text{C}}$	High temperature at 4.1V	Normal charging to high temp CHG; V_{TS} : 0.5V \rightarrow 0.2V	263	278	293	mV
$V_{\text{HYS-45}^{\circ}\text{C}}$	Hysteresis at 45°C	High temp charging to normal CHG; V_{TS} : 0.2V \rightarrow 0.5V		10.7		mV
$V_{\text{TS-60}^{\circ}\text{C}}$	High temperature Disable, bq24092/3	High temp charge to pending; V_{TS} : 0.2V \rightarrow 0.1V	170	178	186	mV
$V_{\text{HYS-60}^{\circ}\text{C}}$	Hysteresis at 60°C, bq24092/3	Charge pending to high temp CHG; V_{TS} : 0.1V \rightarrow 0.2V		11.5		mV
$t_{\text{DGL(TS-10C)}}$	Deglitch for TS thresholds: 10C, bq24092/3	Normal to Cold Operation; V_{TS} : 0.6V \rightarrow 1V		50		ms
		Cold to Normal Operation; V_{TS} : 1V \rightarrow 0.6V		12		
$t_{\text{DGL(TS)}}$	Deglitch for TS thresholds: 0/45/60C.	Battery charging		30		ms
$V_{\text{TS-EN-10k}}$	Charge Enable Threshold, (10k NTC)	V_{TS} : 0V \rightarrow 0.175V;	80	88	96	mV
$V_{\text{TS-DIS-HYS-10k}}$	HYS below $V_{\text{TS-EN-10k}}$ to Disable, (10k NTC)	V_{TS} : 0.125V \rightarrow 0V;		12		mV
$V_{\text{TS-EN-100k}}$	Charge Enable Threshold, bq24090/2	V_{TS} : 0V \rightarrow 0.175V;	140	150	160	mV
$V_{\text{TS-DIS-HYS-100k}}$	HYS below $V_{\text{TS-EN-100k}}$ to Disable, bq24091/3	V_{TS} : 0.125V \rightarrow 0V;		50		mV
THERMAL REGULATION						
$T_{\text{J(REG)}}$	Temperature regulation limit			125		$^{\circ}\text{C}$
$T_{\text{J(OFF)}}$	Thermal shutdown temperature			155		$^{\circ}\text{C}$
$T_{\text{J(OFF-HYS)}}$	Thermal shutdown hysteresis			20		$^{\circ}\text{C}$
LOGIC LEVELS ON ISET2						
V_{IL}	Logic LOW input voltage	Sink 8 μA			0.4	V
V_{IH}	Logic HIGH input voltage	Source 8 μA	1.4			V
I_{IL}	Sink current required for LO	$V_{\text{ISET2}} = 0.4\text{V}$	2		9	μA
I_{IH}	Source current required for HI	$V_{\text{ISET2}} = 1.4\text{V}$	1.1		8	μA
V_{FLT}	ISET2 Float Voltage		575	900	1225	mV
LOGIC LEVELS ON CHG AND PG						
V_{OL}	Output LOW voltage	$I_{\text{SINK}} = 5\text{mA}$			0.4	V
I_{LEAK}	Leakage current into IC	$V_{\text{CHG}} = 5\text{V}$, $V_{\text{PG}} = 5\text{V}$			1	μA

8.7 Typical Characteristics

SETUP: bq2409x typical applications schematic; $V_{IN} = 5V$, $V_{BAT} = 3.6V$ (unless otherwise indicated)

8.7.1 Power Up, Power Down, OVP, Disable and Enable Waveforms

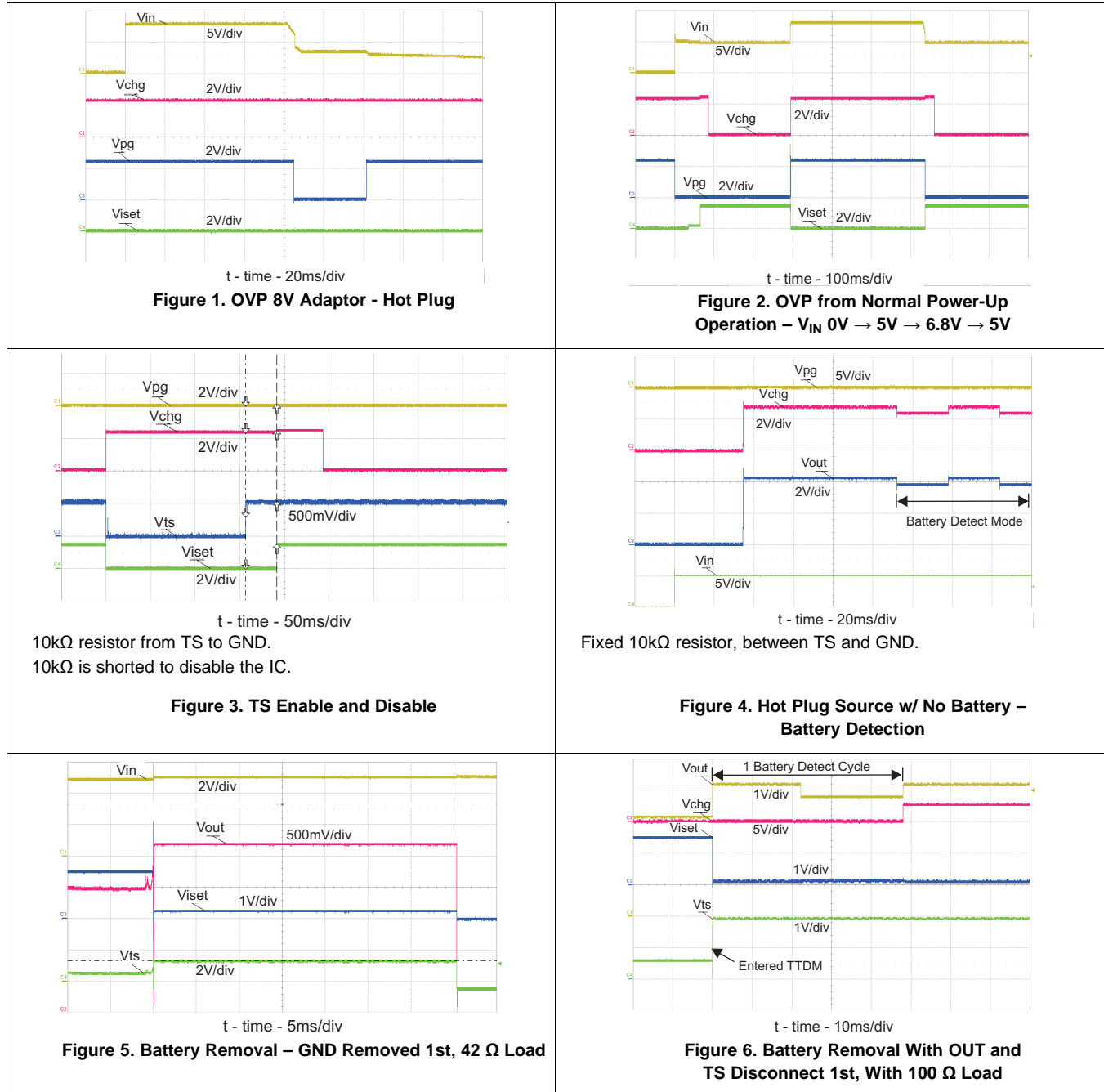

8.7.2 Protection Circuits Waveforms

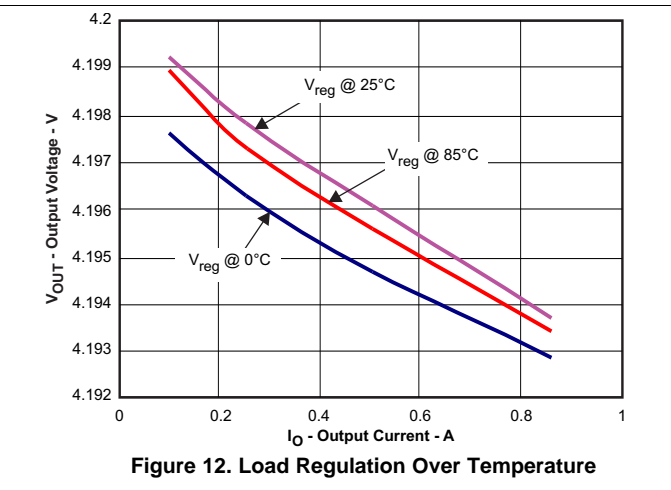
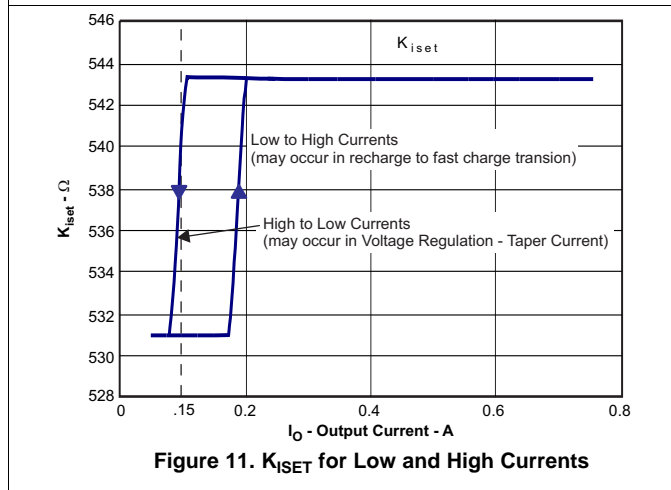
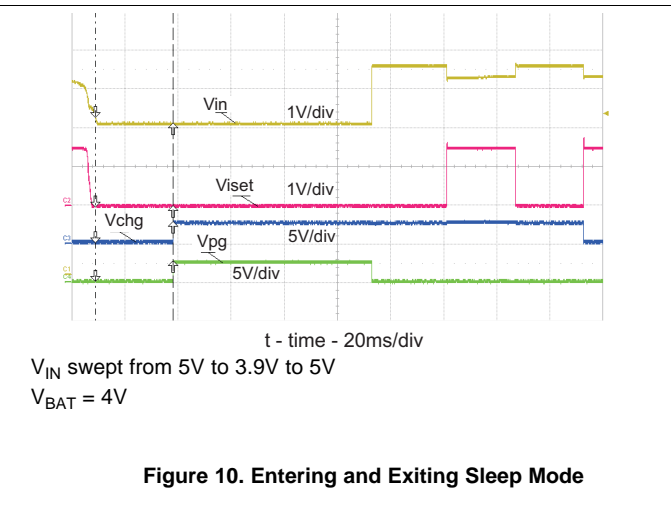
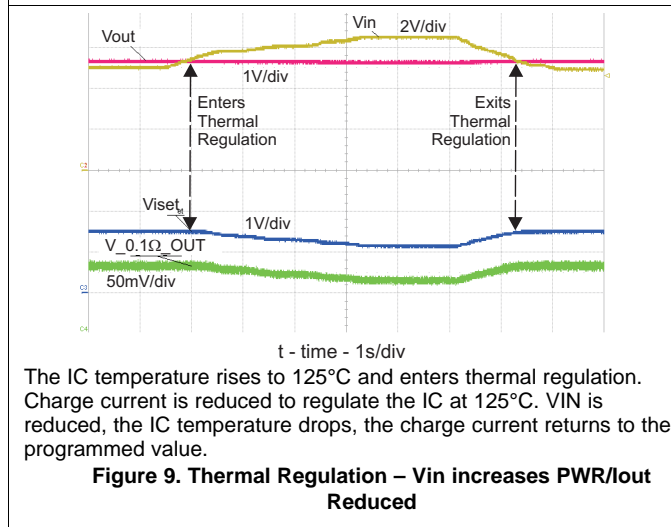
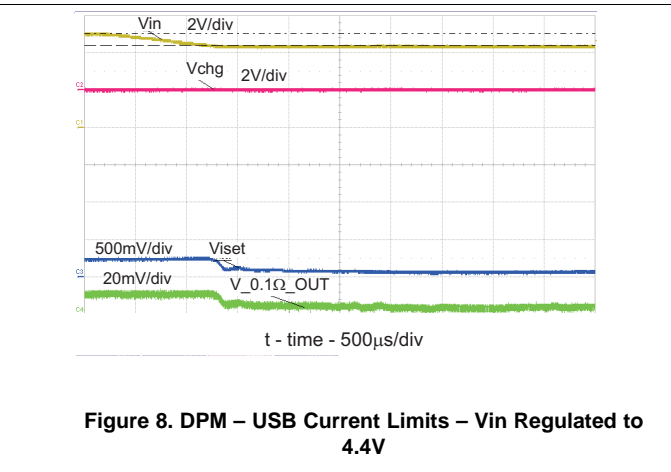
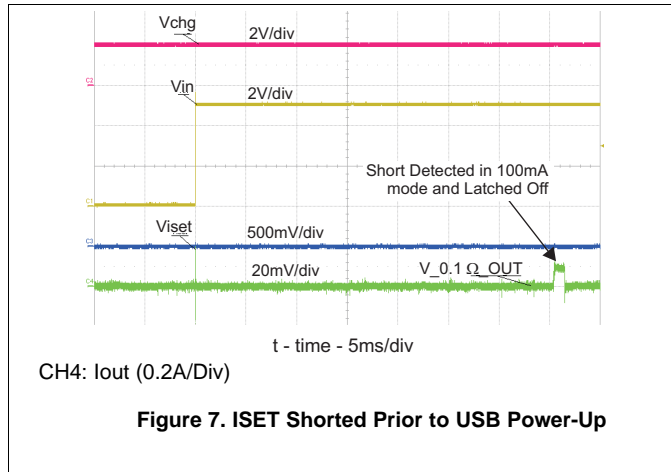

Protection Circuits Waveforms (continued)

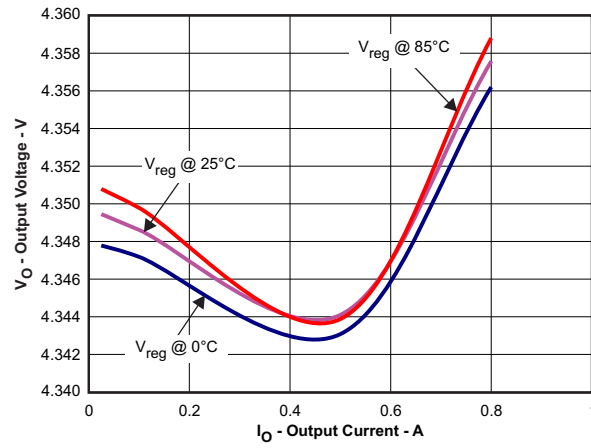

Figure 13. Load Regulation – bq24095

9 Detailed Description

9.1 Overview

The bq2409x is a highly-integrated family of single cell Li-Ion and Li-Pol chargers. The charger can be used to charge a battery, power a system or both. The charger has three phases of charging: Pre-charge to recover a fully discharged battery, fast-charge constant current to supply the buck charge safely and voltage regulation to safely reach full capacity. The charger is very flexible, allowing programming of the fast-charge current and Pre-charge/Termination Current. This charger is designed to work with a USB connection or Adaptor (DC out). The charger also checks to see if a battery is present.

The charger also comes with a full set of safety features: JEITA Temperature Standard, Over-Voltage Protection, DPM-IN, Safety Timers, and ISET short protection. All of these features and more are described in detail below.

The charger is designed for a single power path from the input to the output to charge a single cell Li-Ion or Li-Pol battery pack. Upon application of a 5VDC power source the ISET and OUT short checks are performed to assure a proper charge cycle.

If the battery voltage is below the LOWV threshold, the battery is considered discharged and a preconditioning cycle begins. The amount of precharge current can be programmed using the PRE-TERM pin which programs a percent of fast charge current (10 to 100%) as the precharge current. This feature is useful when the system load is connected across the battery “stealing” the battery current. The precharge current can be set higher to account for the system loading while allowing the battery to be properly conditioned. The PRE-TERM pin is a dual function pin which sets the precharge current level and the termination threshold level. The termination “current threshold” is always half of the precharge programmed current level.

Once the battery voltage has charged to the V_{LOWV} threshold, fast charge is initiated and the fast charge current is applied. The fast charge constant current is programmed using the ISET pin. The constant current provides the bulk of the charge. Power dissipation in the IC is greatest in fast charge with a lower battery voltage. If the IC reaches 125°C the IC enters thermal regulation, slows the timer clock by half and reduce the charge current as needed to keep the temperature from rising any further. [Figure 14](#) shows the charging profile with thermal regulation. Typically under normal operating conditions, the IC’s junction temperature is less than 125°C and thermal regulation is not entered.

Once the cell has charged to the regulation voltage the voltage loop takes control and holds the battery at the regulation voltage until the current tapers to the termination threshold. The termination can be disabled if desired. The CHG pin is low (LED on) during the first charge cycle only and turns off once the termination threshold is reached, regardless if termination, for charge current, is enabled or disabled.

Further details are mentioned in the [Feature Description](#) section.

Overview (continued)

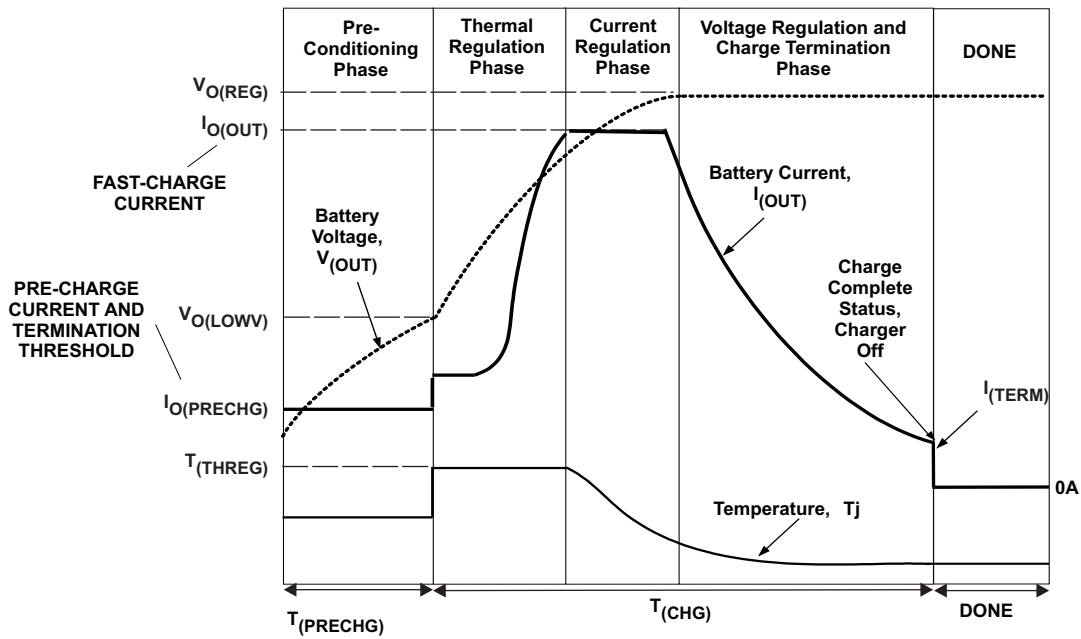
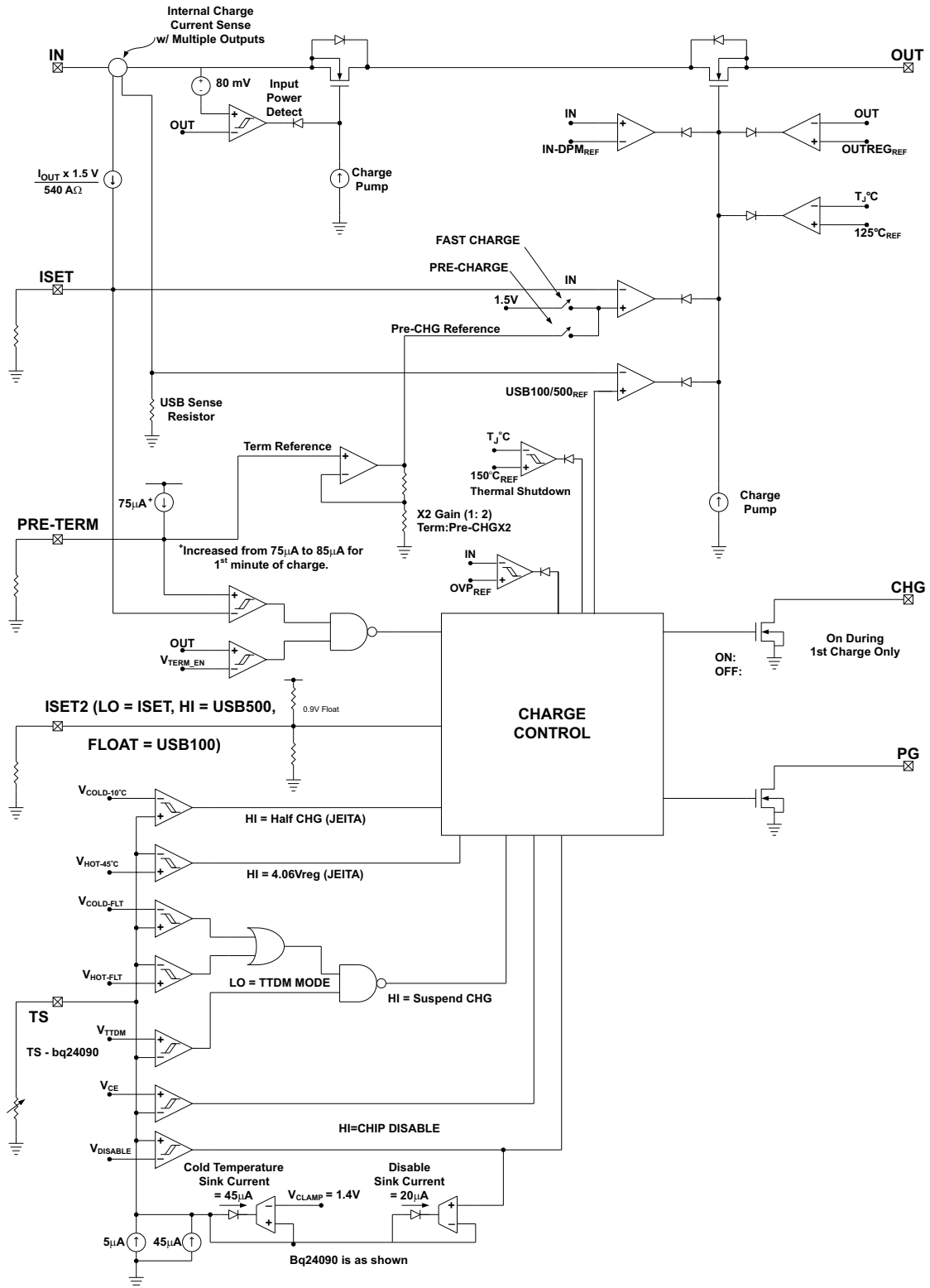

Figure 14. Charging Profile With Thermal Regulation

9.2 Functional Block Diagram



9.3 Feature Description

9.3.1 Power-Down or Undervoltage Lockout (UVLO)

The bq2409x family is in power down mode if the IN pin voltage is less than UVLO. The part is considered “dead” and all the pins are high impedance. Once the IN voltage rises above the UVLO threshold the IC will enter Sleep Mode or Active mode depending on the OUT pin (battery) voltage.

9.3.2 UVLO

The bq2409x family is in power down mode if the IN pin voltage is less than V_{UVLO} . The part is considered “dead” and all the pins are high impedance.

9.3.3 Power-Up

The IC is alive after the IN voltage ramps above UVLO (see sleep mode), resets all logic and timers, and starts to perform many of the continuous monitoring routines. Typically the input voltage quickly rises through the UVLO and sleep states where the IC declares power good, starts the qualification charge at 100mA, sets the input current limit threshold base on the ISET2 pin, starts the safety timer and enables the CHG pin. See [Figure 15](#).

9.3.4 Sleep Mode

If the IN pin voltage is between than $V_{OUT}+V_{DT}$ and UVLO, the charge current is disabled, the safety timer counting stops (not reset) and the \overline{PG} and CHG pins are high impedance. As the input voltage rises and the charger exits sleep mode, the \overline{PG} pin goes low, the safety timer continues to count, charge is enabled and the CHG pin returns to its previous state. See [Figure 16](#).

9.3.5 New Charge Cycle

A new charge cycle is started when a good power source is applied, performing a chip disable/enable (TS pin), exiting Termination and Timer Disable Mode (TTDM), detecting a battery insertion or the OUT voltage dropping below the V_{RCH} threshold. The CHG pin is active low only during the first charge cycle, therefore exiting TTDM or a dropping below V_{RCH} will not turn on the CHG pin FET, if the CHG pin is already high impedance.

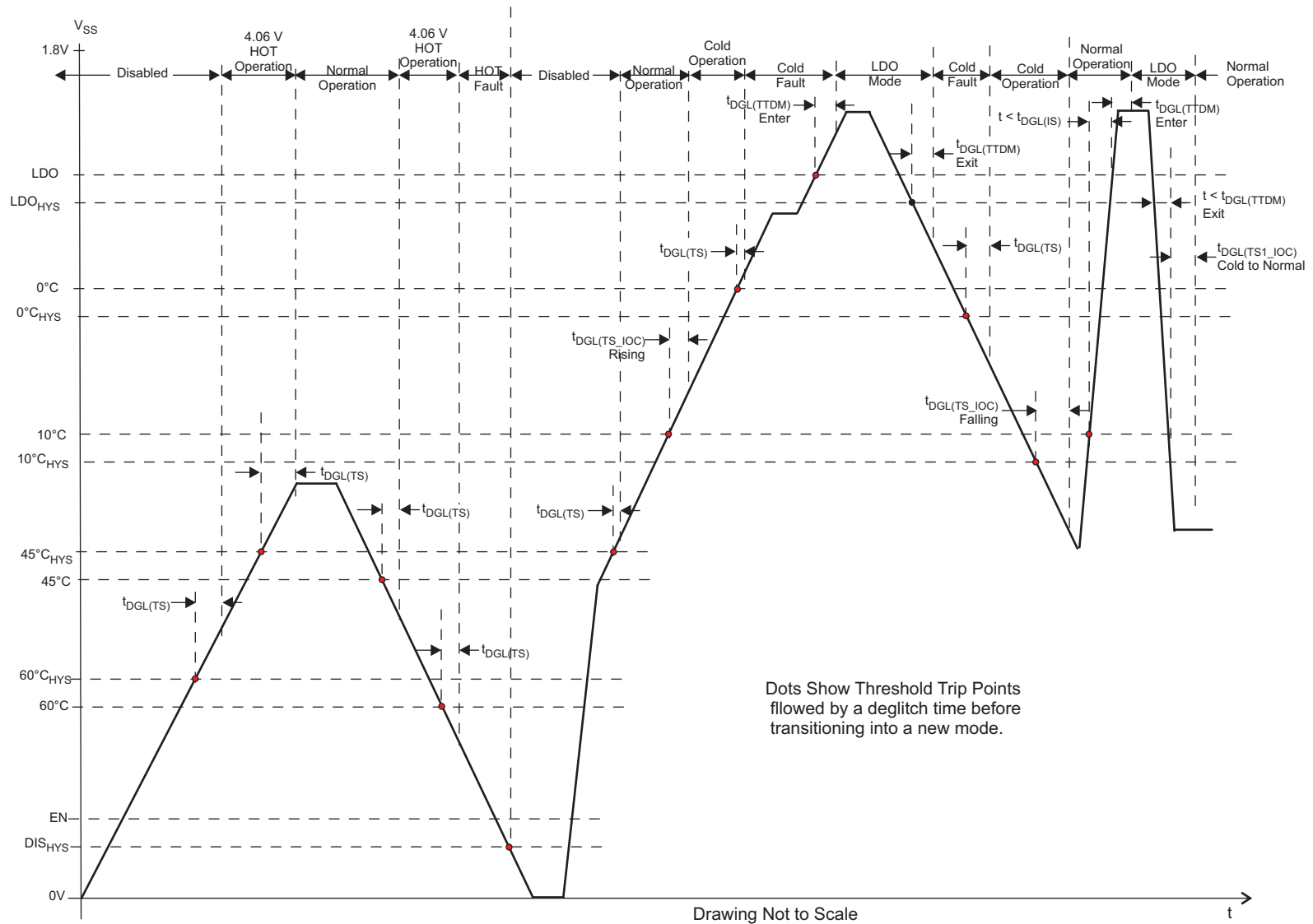

Figure 15. TS Battery Temperature Bias Threshold and Deglitch Timers

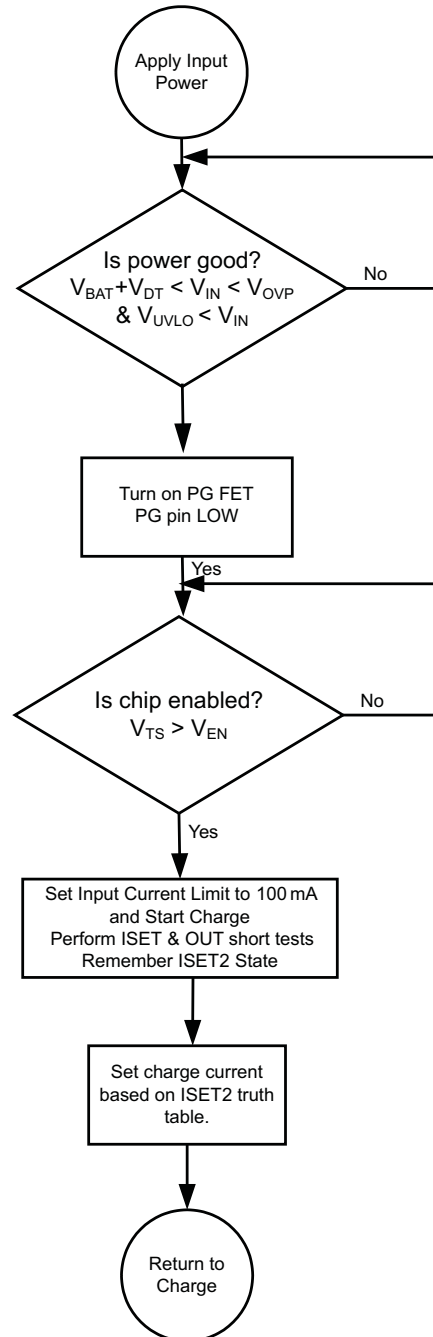

Figure 16. bq2409x Power-Up Flow Diagram

9.3.6 Overvoltage-Protection (OVP) – Continuously Monitored

If the input source applies an overvoltage, the pass FET, if previously on, turns off after a deglitch, $t_{BLK(OVP)}$. The timer ends and the \overline{CHG} and \overline{PG} pin goes to a high impedance state. Once the overvoltage returns to a normal voltage, the \overline{PG} pin goes low, timer continues, charge continues and the \overline{CHG} pin goes low after a 25ms deglitch. PG pin is optional on some packages

9.3.7 Power Good Indication (\overline{PG})

After application of a 5V source, the input voltage rises above the UVLO and sleep thresholds ($V_{IN} > V_{BAT} + V_{DT}$), but is less than OVP ($V_{IN} < V_{OVP}$), then the PG FET turns on and provides a low impedance path to ground. See [Figure 1](#), [Figure 2](#), and [Figure 10](#).

9.3.8 $\overline{\text{CHG}}$ Pin Indication

The charge pin has an internal open drain FET which is on (pulls down to V_{SS}) during the first charge only (independent of TTDM) and is turned off once the battery reaches voltage regulation and the charge current tapers to the termination threshold set by the PRE-TERM resistor.

The charge pin is high impedance in sleep mode and OVP (if $\overline{\text{PG}}$ is high impedance) and return to its previous state once the condition is removed.

Cycling input power, pulling the TS pin low and releasing or entering pre-charge mode causes the $\overline{\text{CHG}}$ pin to go reset (go low if power is good and a discharged battery is attached) and is considered the start of a first charge.

9.3.9 $\overline{\text{CHG}}$ and $\overline{\text{PG}}$ LED Pull-Up Source

For host monitoring, a pull-up resistor is used between the STATUS pin and the V_{CC} of the host and for a visual indication a resistor in series with an LED is connected between the STATUS pin and a power source. If the $\overline{\text{CHG}}$ or $\overline{\text{PG}}$ source is capable of exceeding 7V, a 6.2V Zener diode should be used to clamp the voltage. If the source is the OUT pin, note that as the battery changes voltage, the brightness of the LEDs vary.

Table 1. $\overline{\text{CHG}}$ Pull-Up Source

Charging State	$\overline{\text{CHG}}$ FET/LED
1st Charge	ON
Refresh Charge	OFF
OVP	
SLEEP	
TEMP FAULT	ON for 1st Charge

Table 2. $\overline{\text{PG}}$ LED Pull-up Source

V_{IN} Power Good State	$\overline{\text{PG}}$ FET/LED
UVLO	OFF
SLEEP Mode	
OVP Mode	
Normal Input ($V_{OUT} + V_{DT} < V_{IN} < V_{OUP}$)	ON
PG is independent of chip disable	

9.3.10 IN-DPM (V_{IN-DPM} or IN-DPM)

The IN-DPM feature is used to detect an input source voltage that is folding back (voltage dropping), reaching its current limit due to excessive load. When the input voltage drops to the V_{IN-DPM} threshold the internal pass FET starts to reduce the current until there is no further drop in voltage at the input. This would prevent a source with voltage less than V_{IN-DPM} to power the out pin. This works well with current limited adaptors and USB ports as long as the nominal voltage is above 4.3V and 4.4V respectively. This is an added safety feature that helps protect the source from excessive loads.

9.3.11 OUT

The Charger's OUT pin provides current to the battery and to the system, if present. This IC can be used to charge the battery plus power the system, charge just the battery or just power the system (TTDM) assuming the loads do not exceed the available current. The OUT pin is a current limited source and is inherently protected against shorts. If the system load ever exceeds the output programmed current threshold, the output will be discharged unless there is sufficient capacitance or a charged battery present to supplement the excessive load.

9.3.12 ISET

An external resistor is used to Program the Output Current (50 to 1000mA) and can be used as a current monitor.

$$R_{ISET} = K_{ISET} / I_{OUT}$$

where

- I_{OUT} is the desired fast charge current
- K_{ISET} is a gain factor found in the electrical specification

(0)

For greater accuracy at lower currents, part of the sense FET is disabled to give better resolution. Figure 11 shows the transition from low current to higher current. Going from higher currents to low currents, there is hysteresis and the transition occurs around 0.15A.

The ISET resistor is short protected and will detect a resistance lower than $\approx 340\Omega$. The detection requires at least 80mA of output current. If a “short” is detected, then the IC will latch off and can only be reset by cycling the power. The OUT current is internally clamped to a maximum current between 1.1A and 1.35A and is independent of the ISET short detection circuitry, as shown in Figure 18. Also, see Figure 24 and Figure 7.

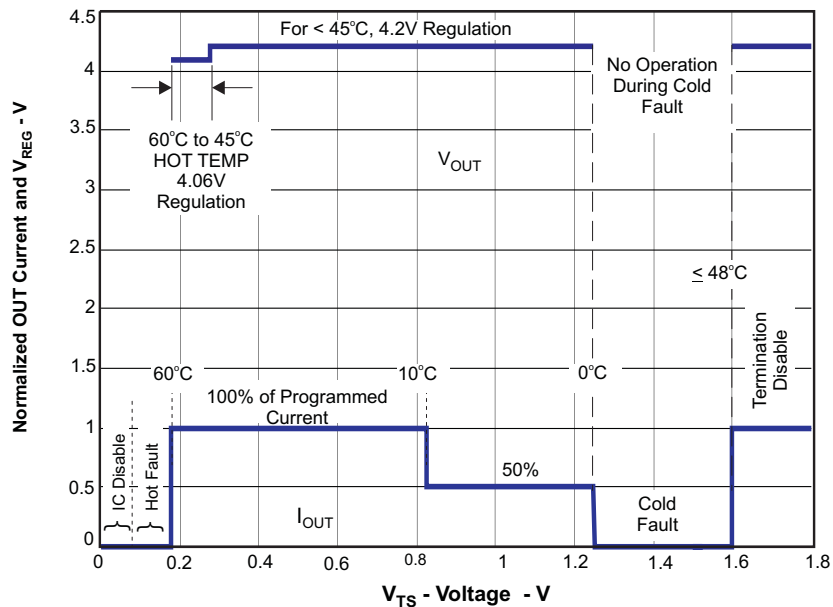

Figure 17. Operation Over TS Bias Voltage

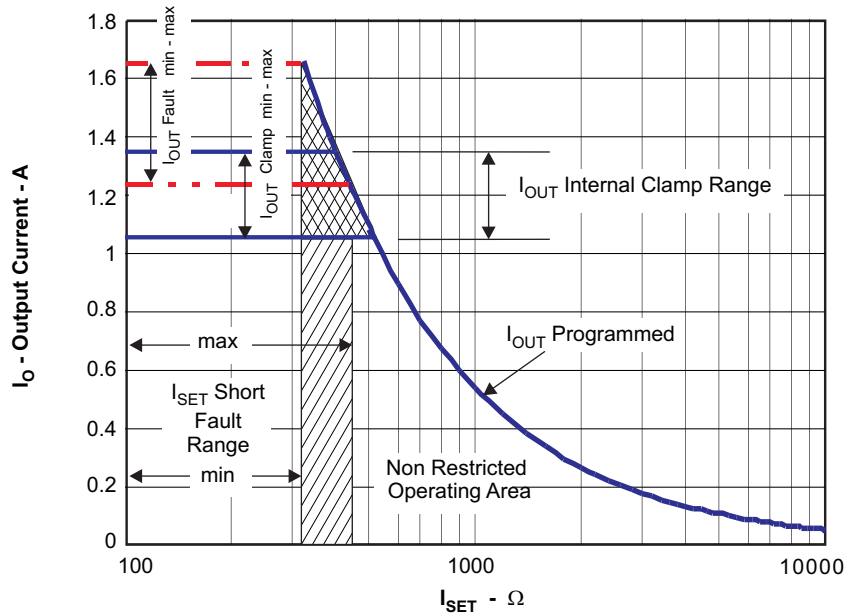

Figure 18. Programmed/Clamped Out Current

9.3.13 PRE_TERM – Pre-Charge and Termination Programmable Threshold

PRE_TERM is used to program both the pre-charge current and the termination current threshold. The pre-charge current level is a factor of two higher than the termination current level. The termination can be set between 5% and 50% of the programmed output current level set by ISET. If left floating the termination and pre-charge are set internally at 10/20% respectively. The pre-charge-to-fast-charge, V_{lowv} threshold is set to 2.5V.

$$R_{PRE_TERM} = \%Term \times K_{TERM} = \%Pre_CHG \times K_{PRE_CHG}$$

where

- %Term is the percent of fast charge current where termination occurs
- %Pre-CHG is the percent of fast charge current that is desired during precharge
- K_{TERM} and K_{PRE-CHG} are gain factors found in the electrical specifications

(1)

9.3.14 ISET2

ISET2 is a 3-state input and programs the Input Current Limit/Regulation Threshold. A low will program a regulated fast charge current via the ISET resistor and is the maximum allowed input/output current for any ISET2 setting, Float will program a 100mA Current limit and High will program a 500mA Current limit.

Below are two configurations for driving the 3-state ISET2 pin:

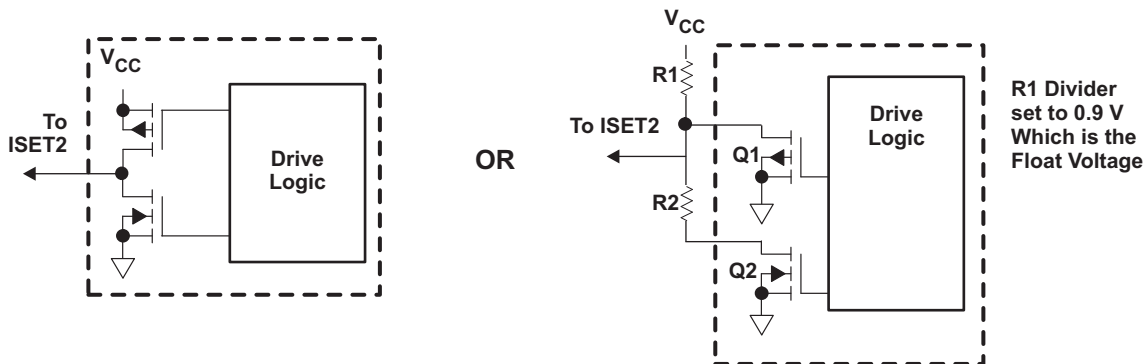

Figure 19. Configurations for Driving the 3-State ISET2 Pin

9.3.15 TS

The bq2409x family contains an NTC monitoring function. The TS function for bq24090, bq24091 and bq24095 follow the classic temperature range and disable charge when the battery temperature outside of the 0°C and 45°C operating temperature window. The TS function for bq24092 and bq24093 are designed to follow the new JEITA temperature standard for Li-Ion and Li-Pol batteries. There are now four thresholds, 60°C, 45°C, 10°C, and 0°C. Normal operation occurs between 10°C and 45°C. If between 0°C and 10°C the charge current level is cut in half and if between 45°C and 60°C the regulation voltage is reduced to 4.1V_{max}, see [Figure 17](#).

The bq2409x family has devices to monitor 10k and 100k NTC thermistors. The bq24090/2/5 are designed to work with a 10k NTC. For these devices, the TS feature is implemented using an internal 50µA current source to bias the thermistor (designed for use with a 10k NTC $\beta = 3370$ (SEMITEC 103AT-2 or Mitsubishi TH05-3H103F) connected from the TS pin to V_{SS}. If this feature is not needed, a fixed 10k can be placed between TS and V_{SS} to allow normal operation. This may be done if the host is monitoring the thermistor and then the host would determine when to pull the TS pin low to disable charge. The bq24091/3 are designed to work with a 100k NTC. For these devices, the TS feature is implemented using an internal 5µA current source to bias the thermistor (designed for use with a 100k NTC $\beta = 3370$) connected from the TS pin to V_{SS}. If this feature is not needed, a fixed 100k can be placed between TS and V_{SS} to allow normal operation. This may be done if the host is monitoring the thermistor and then the host would determine when to pull the TS pin low to disable charge.

The TS pin has two additional features, when the TS pin is pulled low or floated/driven high. A low disables charge (similar to a high on the `BAT_EN` feature) and a high puts the charger in TTDM.

Above 60°C or below 0°C the charge is disabled. Once the thermistor reaches $\approx -10^\circ\text{C}$ the TS current folds back to keep a cold thermistor (between -10°C and -50°C) from placing the IC in the TTDM mode. If the TS pin is pulled low into disable mode, the current is reduced to $\approx 30\mu\text{A}$, see [Figure 15](#). Since the I_{TS} current is fixed along with the temperature thresholds, it is not possible to use thermistor values other than the 10k or 100k (depending on the IC) NTC (at 25°C).

9.4 Device Functional Modes

9.4.1 Termination and Timer Disable Mode (TTDM) -TS Pin High

The battery charger is in TTDM when the TS pin goes high from removing the thermistor (removing battery pack/floating the TS pin) or by pulling the TS pin up to the TTDM threshold.

When entering TTDM, the 10 hour safety timer is held in reset and termination is disabled. A battery detect routine is run to see if the battery was removed or not. If the battery was removed then the `CHG` pin will go to its high impedance state if not already there. If a battery is detected the `CHG` pin does not change states until the current tapers to the termination threshold, where the `CHG` pin goes to its high impedance state if not already there (the regulated output will remain on).

The charging profile does not change (still has pre-charge, fast-charge constant current and constant voltage modes). This implies the battery is still charged safely and the current is allowed to taper to zero.

When coming out of TTDM, the battery detect routine is run and if a battery is detected, then a new charge cycle begins and the `CHG` LED turns on.

If TTDM is not desired upon removing the battery with the thermistor, one can add a 237k resistor between TS and V_{SS} to disable TTDM. This keeps the current source from driving the TS pin into TTDM. This creates $\approx 0.1^\circ\text{C}$ error at hot and a $\approx 3^\circ\text{C}$ error at cold.

9.4.2 Timers

The pre-charge timer is set to 30 minutes. The pre-charge current, can be programmed to off-set any system load, making sure that the 30 minutes is adequate.

The fast charge timer is fixed at 10 hours and can be increased real time by going into thermal regulation, IN-DPM or if in USB current limit. The timer clock slows by a factor of 2, resulting in a clock that counts half as fast when in these modes. If either the 30 minute or ten hour timer times out, the charging is terminated and the `CHG` pin goes high impedance if not already in that state. The timer is reset by disabling the IC, cycling power or going into and out of TTDM.

Device Functional Modes (continued)

9.4.3 Termination

Once the OUT pin goes above VRCH, (reaches voltage regulation) and the current tapers down to the termination threshold, the CHG pin goes high impedance and a battery detect routine is run to determine if the battery was removed or the battery is full. If the battery is present, the charge current will terminate. If the battery was removed along with the thermistor, then the TS pin is driven high and the charge enters TTDM. If the battery was removed and the TS pin is held in the active region, then the battery detect routine will continue until a battery is inserted.

9.4.4 Battery Detect Routine

The battery detect routine should check for a missing battery while keeping the OUT pin at a useable voltage. Whenever the battery is missing the CHG pin should be high impedance.

The battery detect routine is run when entering and exiting TTDM to verify if battery is present, or run all the time if battery is missing and not in TTDM. On power-up, if battery voltage is greater than V_{RCH} threshold, a battery detect routine is run to determine if a battery is present.

The battery detect routine is disabled while the IC is in TTDM, or has a TS fault. See [Figure 20](#) for the Battery Detect Flow Diagram.

9.4.5 Refresh Threshold

After termination, if the OUT pin voltage drops to V_{RCH} (100mV below regulation) then a new charge is initiated, but the CHG pin remains at a high impedance (off).

9.4.6 Starting a Charge on a Full Battery

The termination threshold is raised by $\pm 14\%$, for the first minute of a charge cycle so if a full battery is removed and reinserted or a new charge cycle is initiated, that the new charge terminates (less than 1 minute). Batteries that have relaxed many hours may take several minutes to taper to the termination threshold and terminate charge.

Device Functional Modes (continued)

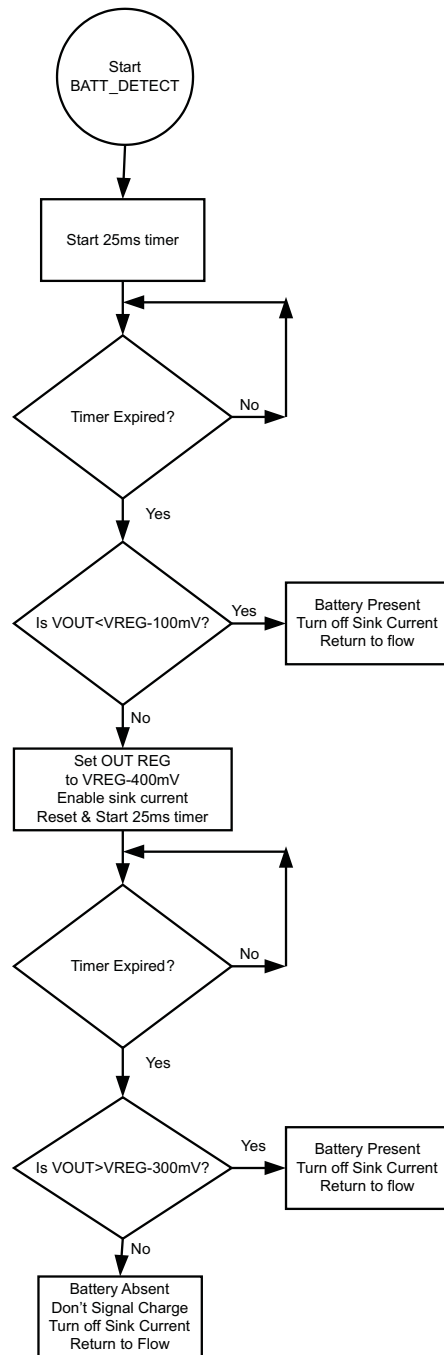

Figure 20. Battery Detect Routine

10 Application and Implementation

NOTE

Information in the following applications sections is not part of the TI component specification, and TI does not warrant its accuracy or completeness. TI's customers are responsible for determining suitability of components for their purposes. Customers should validate and test their design implementation to confirm system functionality.

10.1 Application Information

The bq2409x series of devices are highly integrated Li-Ion and Li-Pol linear chargers devices targeted at space-limited portable applications. The devices operate from either a USB port or AC adaptor. The high input voltage range with input overvoltage protection supports low-cost unregulated adaptors. These devices have a single power output that charges the battery. A system load can be placed in parallel with the battery as long as the average system load does not keep the battery from charging fully during the 10 hour safety timer.

10.2 Typical Application

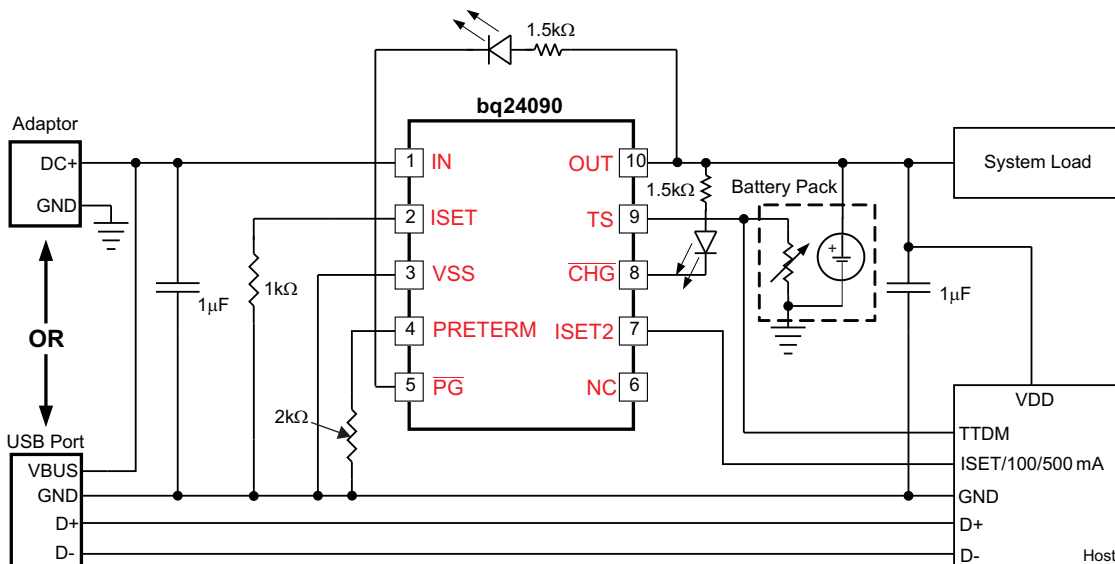

Figure 21. Typical Application Schematic

10.2.1 Design Requirements

- Supply voltage = 5 V
- Fast charge current: $I_{OUT-FC} = 540 \text{ mA}$; ISET-pin 2
- Termination Current Threshold: $\%I_{OUT-FC} = 10\%$ of Fast Charge or approximately 54mA
- Pre-Charge Current by default is twice the termination Current or approximately 108mA
- TS – Battery Temperature Sense = 10k NTC (103AT)

10.2.2 Detailed Design Procedure

10.2.2.1 Calculations

10.2.2.1.1 Program the Fast Charge Current, ISET:

$$R_{ISET} = [K_{(ISET)} / I_{(OUT)}]$$

from electrical characteristics table. . . $K_{(SET)} = 540A\Omega$

$$R_{ISET} = [540A\Omega / 0.54A] = 1.0 \text{ k}\Omega$$

Selecting the closest standard value, use a 1 kΩ resistor between ISET (pin 16) and V_{SS} .

Typical Application (continued)

10.2.2.1.2 Program the Termination Current Threshold, ITERM:

$$R_{\text{PRE-TERM}} = K_{(\text{TERM})} \times \%_{\text{IOUT-FC}}$$

$$R_{\text{PRE-TERM}} = 200\Omega/\% \times 10\% = 2\text{k}\Omega$$

Selecting the closest standard value, use a 2 kΩ resistor between ITERM (pin 15) and Vss.

One can arrive at the same value by using 20% for a pre-charge value (factor of 2 difference).

$$R_{\text{PRE-TERM}} = K_{(\text{PRE-CHG})} \times \%_{\text{IOUT-FC}}$$

$$R_{\text{PRE-TERM}} = 100\Omega/\% \times 20\% = 2\text{k}\Omega$$

10.2.2.1.3 TS Function

Use a 10kΩ NTC thermistor in the battery pack (103AT).

To Disable the temp sense function, use a fixed 10kΩ resistor between the TS (Pin 1) and Vss.

10.2.2.1.4 $\overline{\text{CHG}}$ and PG

LED Status: connect a 1.5kΩ resistor in series with a LED between the OUT pin and the $\overline{\text{CHG}}$ pin.

Connect a 1.5kΩ resistor in series with a LED between the OUT pin and the and PG pin.

Processor Monitoring: Connect a pull-up resistor between the processor's power rail and the $\overline{\text{CHG}}$ pin.

Connect a pull-up resistor between the processor's power rail and the PG pin.

10.2.2.2 Selecting IN and OUT Pin Capacitors

In most applications, all that is needed is a high-frequency decoupling capacitor (ceramic) on the power pin, input and output pins. Using the values shown on the application diagram, is recommended. After evaluation of these voltage signals with real system operational conditions, one can determine if capacitance values can be adjusted toward the minimum recommended values (DC load application) or higher values for fast high amplitude pulsed load applications. Note if designed for high input voltage sources (bad adaptors or wrong adaptors), the capacitor needs to be rated appropriately. Ceramic capacitors are tested to 2x their rated values so a 16V capacitor may be adequate for a 30V transient (verify tested rating with capacitor manufacturer).

10.2.3 Application Curves

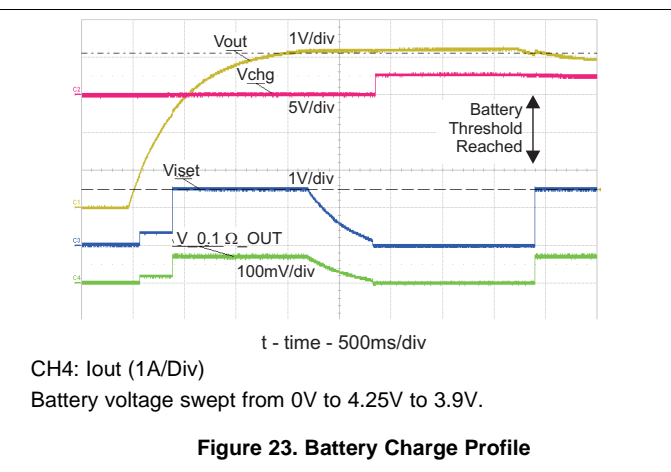
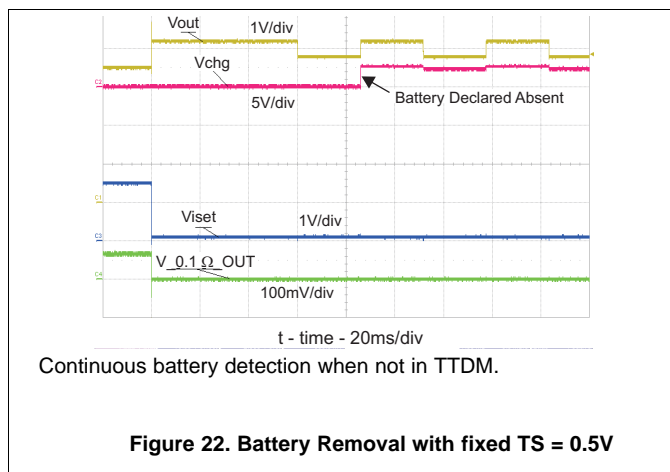

Typical Application (continued)

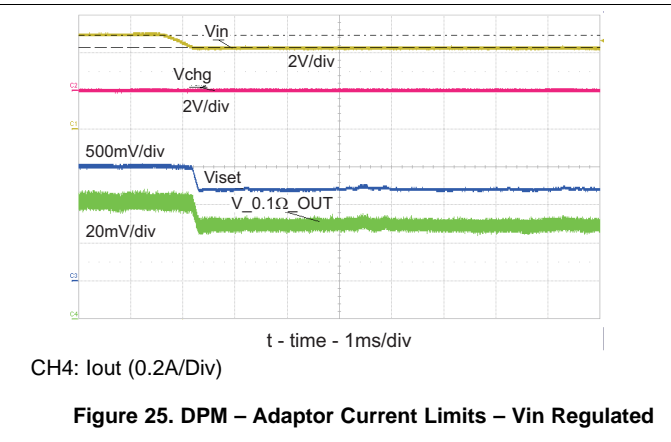
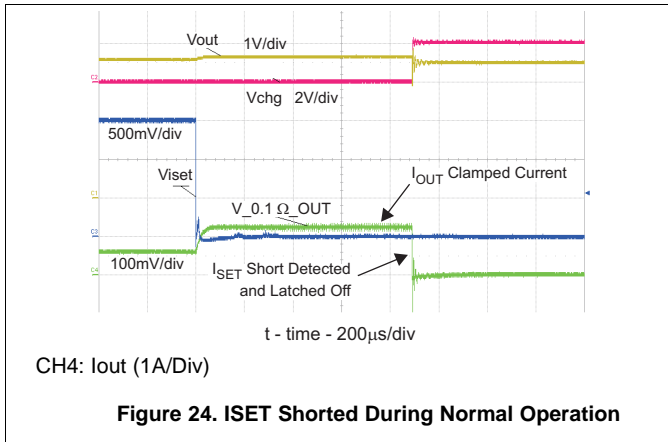

12.3 Thermal Considerations

The bq2409x family is packaged in a thermally enhanced MSOP package. The package includes a thermal pad to provide an effective thermal contact between the IC and the printed circuit board (PCB). The power pad should be directly connected to the VSS pin. Full PCB design guidelines for this package are provided in the application note entitled: Power Pad Thermally Enhanced Package Note ([SLMA002](#)). The most common measure of package thermal performance is thermal impedance (θ_{JA}) measured (or modeled) from the chip junction to the air surrounding the package surface (ambient). The mathematical expression for θ_{JA} is:

$$\theta_{JA} = (T_J - T) / P$$

where

- T_J = chip junction temperature
- T = ambient temperature
- P = device power dissipation

(2) (2)

Factors that can influence the measurement and calculation of θ_{JA} include:

- Whether or not the device is board mounted
- Trace size, composition, thickness, and geometry
- Orientation of the device (horizontal or vertical)
- Volume of the ambient air surrounding the device under test and airflow
- Whether other surfaces are in close proximity to the device being tested

Due to the charge profile of Li-Ion and Li-Pol batteries the maximum power dissipation is typically seen at the beginning of the charge cycle when the battery voltage is at its lowest. Typically after fast charge begins the pack voltage increases to $\approx 3.4V$ within the first 2 minutes. The thermal time constant of the assembly typically takes a few minutes to heat up so when doing maximum power dissipation calculations, 3.4V is a good minimum voltage to use. This is verified, with the system and a fully discharged battery, by plotting temperature on the bottom of the PCB under the IC (pad should have multiple vias), the charge current and the battery voltage as a function of time. The fast charge current will start to taper off if the part goes into thermal regulation.

The device power dissipation, P , is a function of the charge rate and the voltage drop across the internal PowerFET. It can be calculated from the following equation when a battery pack is being charged :

$$P = [V_{(IN)} - V_{(OUT)}] \times I_{(OUT)} + [V_{(OUT)} - V_{(BAT)}] \times I_{(BAT)} \quad (2)$$

The thermal loop feature reduces the charge current to limit excessive IC junction temperature. It is recommended that the design not run in thermal regulation for typical operating conditions (nominal input voltage and nominal ambient temperatures) and use the feature for non typical situations such as hot environments or higher than normal input source voltage. With that said, the IC will still perform as described, if the thermal loop is always active.

12.3.1 Leakage Current Effects on Battery Capacity

To determine how fast a leakage current on the battery will discharge the battery is an easy calculation. The time from full to discharge can be calculated by dividing the Amp-Hour Capacity of the battery by the leakage current. For a 0.75Ahr battery and a 10 μA leakage current (750mAHr/0.010mA = 75000 Hours), it would take 75k hours or 8.8 years to discharge. In reality the self discharge of the cell would be much faster so the 10 μA leakage would be considered negligible.

13 Device and Documentation Support

13.1 Device Support

13.1.1 Third-Party Products Disclaimer

TI'S PUBLICATION OF INFORMATION REGARDING THIRD-PARTY PRODUCTS OR SERVICES DOES NOT CONSTITUTE AN ENDORSEMENT REGARDING THE SUITABILITY OF SUCH PRODUCTS OR SERVICES OR A WARRANTY, REPRESENTATION OR ENDORSEMENT OF SUCH PRODUCTS OR SERVICES, EITHER ALONE OR IN COMBINATION WITH ANY TI PRODUCT OR SERVICE.

13.2 Related Links

The table below lists quick access links. Categories include technical documents, support and community resources, tools and software, and quick access to sample or buy.

Table 3. Related Links

PARTS	PRODUCT FOLDER	SAMPLE & BUY	TECHNICAL DOCUMENTS	TOOLS & SOFTWARE	SUPPORT & COMMUNITY
bq24090	Click here	Click here	Click here	Click here	Click here
bq24091	Click here	Click here	Click here	Click here	Click here
bq24092	Click here	Click here	Click here	Click here	Click here
bq24093	Click here	Click here	Click here	Click here	Click here
bq24095	Click here	Click here	Click here	Click here	Click here

13.3 Trademarks

All trademarks are the property of their respective owners.

13.4 Electrostatic Discharge Caution



These devices have limited built-in ESD protection. The leads should be shorted together or the device placed in conductive foam during storage or handling to prevent electrostatic damage to the MOS gates.

13.5 Glossary

[SLYZ022](#) — *TI Glossary*.

This glossary lists and explains terms, acronyms, and definitions.

14 Mechanical, Packaging, and Orderable Information

The following pages include mechanical, packaging, and orderable information. This information is the most current data available for the designated devices. This data is subject to change without notice and revision of this document. For browser-based versions of this data sheet, refer to the left-hand navigation.

PACKAGING INFORMATION

Orderable Device	Status (1)	Package Type	Package Drawing	Pins	Package Qty	Eco Plan (2)	Lead/Ball Finish (6)	MSL Peak Temp (3)	Op Temp (°C)	Device Marking (4/5)	Samples
BQ24090DGQR	ACTIVE	MSOP-PowerPAD	DGQ	10	2500	Green (RoHS & no Sb/Br)	CU NIPDAUAG	Level-1-260C-UNLIM	0 to 125	24090	Samples
BQ24090DGQT	ACTIVE	MSOP-PowerPAD	DGQ	10	250	Green (RoHS & no Sb/Br)	CU NIPDAUAG	Level-1-260C-UNLIM	0 to 125	24090	Samples
BQ24091DGQR	ACTIVE	MSOP-PowerPAD	DGQ	10	2500	Green (RoHS & no Sb/Br)	CU NIPDAUAG	Level-1-260C-UNLIM	-40 to 150	24091	Samples
BQ24091DGQT	ACTIVE	MSOP-PowerPAD	DGQ	10	250	Green (RoHS & no Sb/Br)	CU NIPDAUAG	Level-1-260C-UNLIM	-40 to 150	24091	Samples
BQ24092DGQR	ACTIVE	MSOP-PowerPAD	DGQ	10	2500	Green (RoHS & no Sb/Br)	CU NIPDAUAG	Level-1-260C-UNLIM	-40 to 150	24092	Samples
BQ24092DGQT	ACTIVE	MSOP-PowerPAD	DGQ	10	250	Green (RoHS & no Sb/Br)	CU NIPDAUAG	Level-1-260C-UNLIM	-40 to 150	24092	Samples
BQ24093DGQR	ACTIVE	MSOP-PowerPAD	DGQ	10	2500	Green (RoHS & no Sb/Br)	CU NIPDAUAG	Level-1-260C-UNLIM	-40 to 150	24093	Samples
BQ24093DGQT	ACTIVE	MSOP-PowerPAD	DGQ	10	250	Green (RoHS & no Sb/Br)	CU NIPDAUAG	Level-1-260C-UNLIM	-40 to 150	24093	Samples
BQ24095DGQR	ACTIVE	MSOP-PowerPAD	DGQ	10	2500	Green (RoHS & no Sb/Br)	CU NIPDAU CU NIPDAUAG	Level-1-260C-UNLIM	0 to 125	24095	Samples
BQ24095DGQT	ACTIVE	MSOP-PowerPAD	DGQ	10	250	Green (RoHS & no Sb/Br)	CU NIPDAU CU NIPDAUAG	Level-1-260C-UNLIM	0 to 125	24095	Samples

(1) The marketing status values are defined as follows:

ACTIVE: Product device recommended for new designs.

LIFEBUY: TI has announced that the device will be discontinued, and a lifetime-buy period is in effect.

NRND: Not recommended for new designs. Device is in production to support existing customers, but TI does not recommend using this part in a new design.

PREVIEW: Device has been announced but is not in production. Samples may or may not be available.

OBSOLETE: TI has discontinued the production of the device.

(2) Eco Plan - The planned eco-friendly classification: Pb-Free (RoHS), Pb-Free (RoHS Exempt), or Green (RoHS & no Sb/Br) - please check <http://www.ti.com/productcontent> for the latest availability information and additional product content details.

TBD: The Pb-Free/Green conversion plan has not been defined.

Pb-Free (RoHS): TI's terms "Lead-Free" or "Pb-Free" mean semiconductor products that are compatible with the current RoHS requirements for all 6 substances, including the requirement that lead not exceed 0.1% by weight in homogeneous materials. Where designed to be soldered at high temperatures, TI Pb-Free products are suitable for use in specified lead-free processes.

Pb-Free (RoHS Exempt): This component has a RoHS exemption for either 1) lead-based flip-chip solder bumps used between the die and package, or 2) lead-based die adhesive used between the die and leadframe. The component is otherwise considered Pb-Free (RoHS compatible) as defined above.

Green (RoHS & no Sb/Br): TI defines "Green" to mean Pb-Free (RoHS compatible), and free of Bromine (Br) and Antimony (Sb) based flame retardants (Br or Sb do not exceed 0.1% by weight in homogeneous material)

- (3) MSL, Peak Temp. - The Moisture Sensitivity Level rating according to the JEDEC industry standard classifications, and peak solder temperature.
- (4) There may be additional marking, which relates to the logo, the lot trace code information, or the environmental category on the device.
- (5) Multiple Device Markings will be inside parentheses. Only one Device Marking contained in parentheses and separated by a "~" will appear on a device. If a line is indented then it is a continuation of the previous line and the two combined represent the entire Device Marking for that device.
- (6) Lead/Ball Finish - Orderable Devices may have multiple material finish options. Finish options are separated by a vertical ruled line. Lead/Ball Finish values may wrap to two lines if the finish value exceeds the maximum column width.

Important Information and Disclaimer:The information provided on this page represents TI's knowledge and belief as of the date that it is provided. TI bases its knowledge and belief on information provided by third parties, and makes no representation or warranty as to the accuracy of such information. Efforts are underway to better integrate information from third parties. TI has taken and continues to take reasonable steps to provide representative and accurate information but may not have conducted destructive testing or chemical analysis on incoming materials and chemicals. TI and TI suppliers consider certain information to be proprietary, and thus CAS numbers and other limited information may not be available for release.

In no event shall TI's liability arising out of such information exceed the total purchase price of the TI part(s) at issue in this document sold by TI to Customer on an annual basis.

TAPE AND REEL INFORMATION



QUADRANT ASSIGNMENTS FOR PIN 1 ORIENTATION IN TAPE



*All dimensions are nominal

Device	Package Type	Package Drawing	Pins	SPQ	Reel Diameter (mm)	Reel Width W1 (mm)	A0 (mm)	B0 (mm)	K0 (mm)	P1 (mm)	W (mm)	Pin1 Quadrant
BQ24090DGQR	MSOP-Power PAD	DGQ	10	2500	330.0	12.4	5.3	3.4	1.4	8.0	12.0	Q1
BQ24090DGQT	MSOP-Power PAD	DGQ	10	250	330.0	12.4	5.3	3.4	1.4	8.0	12.0	Q1
BQ24091DGQR	MSOP-Power PAD	DGQ	10	2500	330.0	12.4	5.3	3.4	1.4	8.0	12.0	Q1
BQ24091DGQT	MSOP-Power PAD	DGQ	10	250	330.0	12.4	5.3	3.4	1.4	8.0	12.0	Q1
BQ24092DGQR	MSOP-Power PAD	DGQ	10	2500	330.0	12.4	5.3	3.4	1.4	8.0	12.0	Q1
BQ24092DGQT	MSOP-Power PAD	DGQ	10	250	330.0	12.4	5.3	3.4	1.4	8.0	12.0	Q1
BQ24092DGQT	MSOP-Power PAD	DGQ	10	250	180.0	12.4	5.3	3.3	1.3	8.0	12.0	Q1
BQ24093DGQR	MSOP-	DGQ	10	2500	330.0	12.4	5.3	3.3	1.3	8.0	12.0	Q1

Device	Package Type	Package Drawing	Pins	SPQ	Reel Diameter (mm)	Reel Width W1 (mm)	A0 (mm)	B0 (mm)	K0 (mm)	P1 (mm)	W (mm)	Pin1 Quadrant
	Power PAD											
BQ24093DGQT	MSOP-Power PAD	DGQ	10	250	330.0	12.4	5.3	3.4	1.4	8.0	12.0	Q1
BQ24093DGQT	MSOP-Power PAD	DGQ	10	250	180.0	12.4	5.3	3.3	1.3	8.0	12.0	Q1
BQ24095DGQR	MSOP-Power PAD	DGQ	10	2500	330.0	12.4	5.3	3.4	1.4	8.0	12.0	Q1
BQ24095DGQT	MSOP-Power PAD	DGQ	10	250	330.0	12.4	5.3	3.4	1.4	8.0	12.0	Q1
BQ24095DGQT	MSOP-Power PAD	DGQ	10	250	180.0	12.4	5.3	3.3	1.3	8.0	12.0	Q1

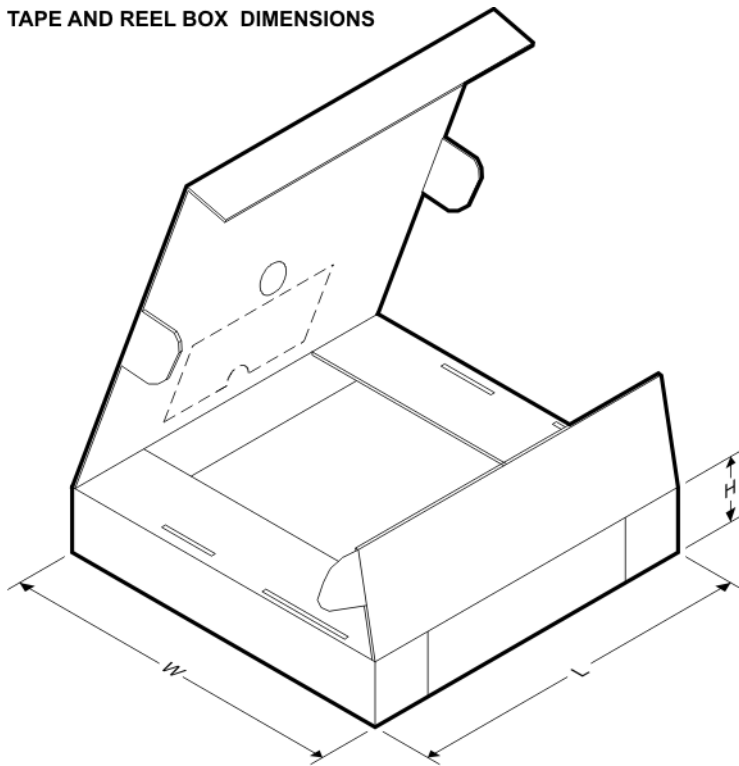
TAPE AND REEL BOX DIMENSIONS

*All dimensions are nominal

Device	Package Type	Package Drawing	Pins	SPQ	Length (mm)	Width (mm)	Height (mm)
BQ24090DGQR	MSOP-PowerPAD	DGQ	10	2500	364.0	364.0	27.0
BQ24090DGQT	MSOP-PowerPAD	DGQ	10	250	364.0	364.0	27.0
BQ24091DGQR	MSOP-PowerPAD	DGQ	10	2500	364.0	364.0	27.0

Device	Package Type	Package Drawing	Pins	SPQ	Length (mm)	Width (mm)	Height (mm)
BQ24091DGQT	MSOP-PowerPAD	DGQ	10	250	364.0	364.0	27.0
BQ24092DGQR	MSOP-PowerPAD	DGQ	10	2500	364.0	364.0	27.0
BQ24092DGQT	MSOP-PowerPAD	DGQ	10	250	364.0	364.0	27.0
BQ24092DGQT	MSOP-PowerPAD	DGQ	10	250	203.0	203.0	35.0
BQ24093DGQR	MSOP-PowerPAD	DGQ	10	2500	346.0	346.0	35.0
BQ24093DGQT	MSOP-PowerPAD	DGQ	10	250	364.0	364.0	27.0
BQ24093DGQT	MSOP-PowerPAD	DGQ	10	250	203.0	203.0	35.0
BQ24095DGQR	MSOP-PowerPAD	DGQ	10	2500	364.0	364.0	27.0
BQ24095DGQT	MSOP-PowerPAD	DGQ	10	250	364.0	364.0	27.0
BQ24095DGQT	MSOP-PowerPAD	DGQ	10	250	203.0	203.0	35.0

DGQ (S-PDSO-G10)

PowerPAD™ PLASTIC SMALL OUTLINE

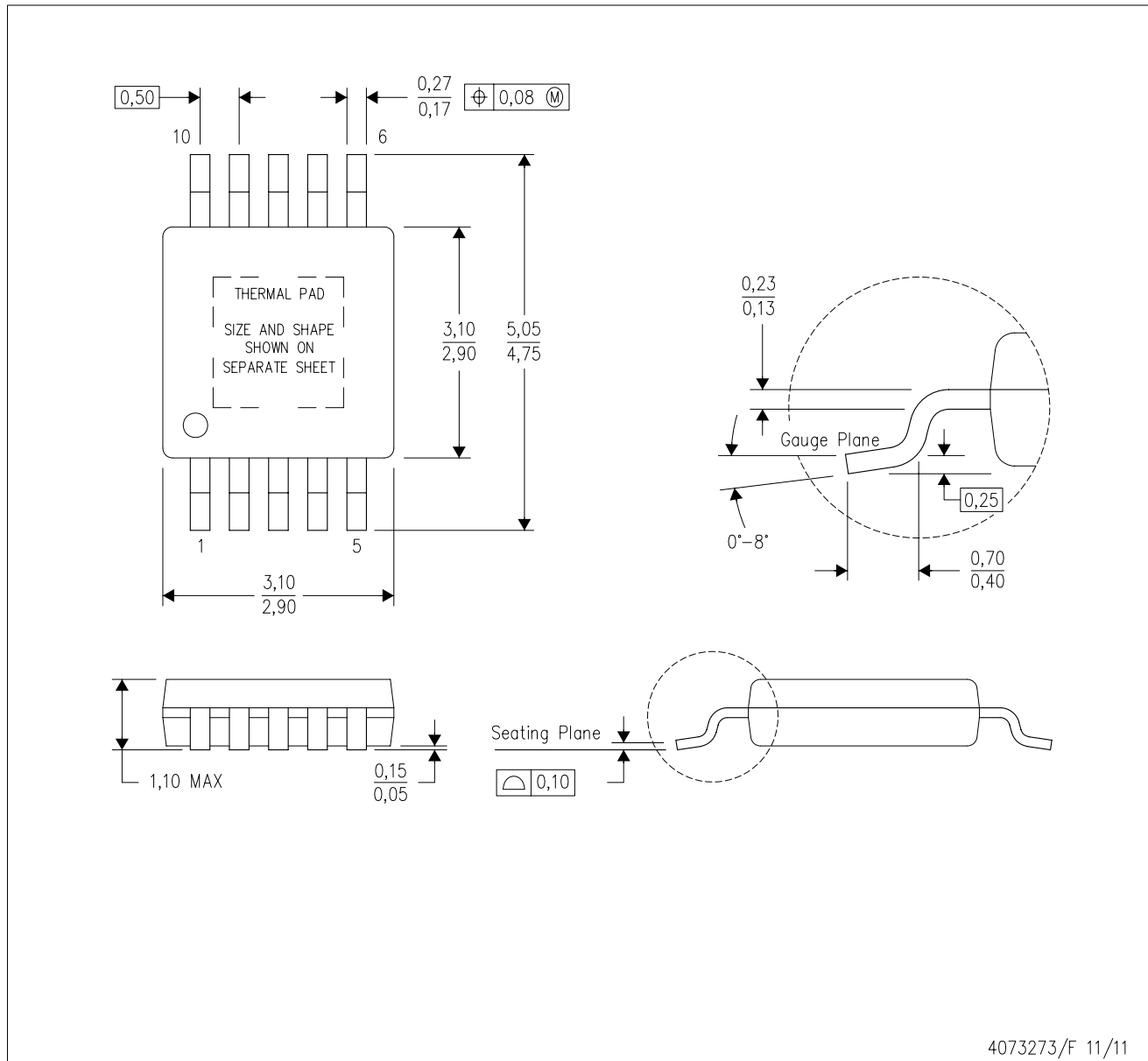

- NOTES:
- A. All linear dimensions are in millimeters.
 - B. This drawing is subject to change without notice.
 - C. Body dimensions do not include mold flash or protrusion not to exceed 0,15.
 - D. This package is designed to be soldered to a thermal pad on the board. Refer to Technical Brief, PowerPad Thermally Enhanced Package, Texas Instruments Literature No. SLMA002 for information regarding recommended board layout. This document is available at www.ti.com <<http://www.ti.com>>.
 - E. See the additional figure in the Product Data Sheet for details regarding the exposed thermal pad features and dimensions.
 - F. Falls within JEDEC MO-187 variation BA-T.

PowerPAD is a trademark of Texas Instruments.

DGQ (S-PDSO-G10)

PowerPAD™ PLASTIC SMALL OUTLINE

THERMAL INFORMATION

This PowerPAD™ package incorporates an exposed thermal pad that is designed to be attached to a printed circuit board (PCB). The thermal pad must be soldered directly to the PCB. After soldering, the PCB can be used as a heatsink. In addition, through the use of thermal vias, the thermal pad can be attached directly to the appropriate copper plane shown in the electrical schematic for the device, or alternatively, can be attached to a special heatsink structure designed into the PCB. This design optimizes the heat transfer from the integrated circuit (IC).

For additional information on the PowerPAD package and how to take advantage of its heat dissipating abilities, refer to Technical Brief, PowerPAD Thermally Enhanced Package, Texas Instruments Literature No. SLMA002 and Application Brief, PowerPAD Made Easy, Texas Instruments Literature No. SLMA004. Both documents are available at www.ti.com.

The exposed thermal pad dimensions for this package are shown in the following illustration.

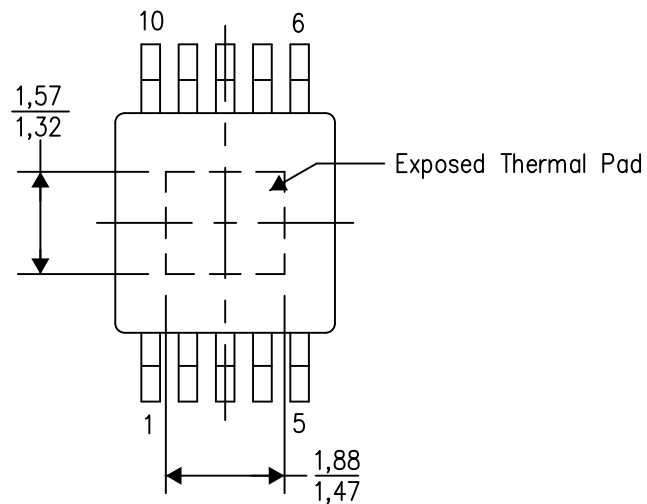

Top View

Exposed Thermal Pad Dimensions

4206324-2/H 12/14

NOTE: A. All linear dimensions are in millimeters

PowerPAD is a trademark of Texas Instruments

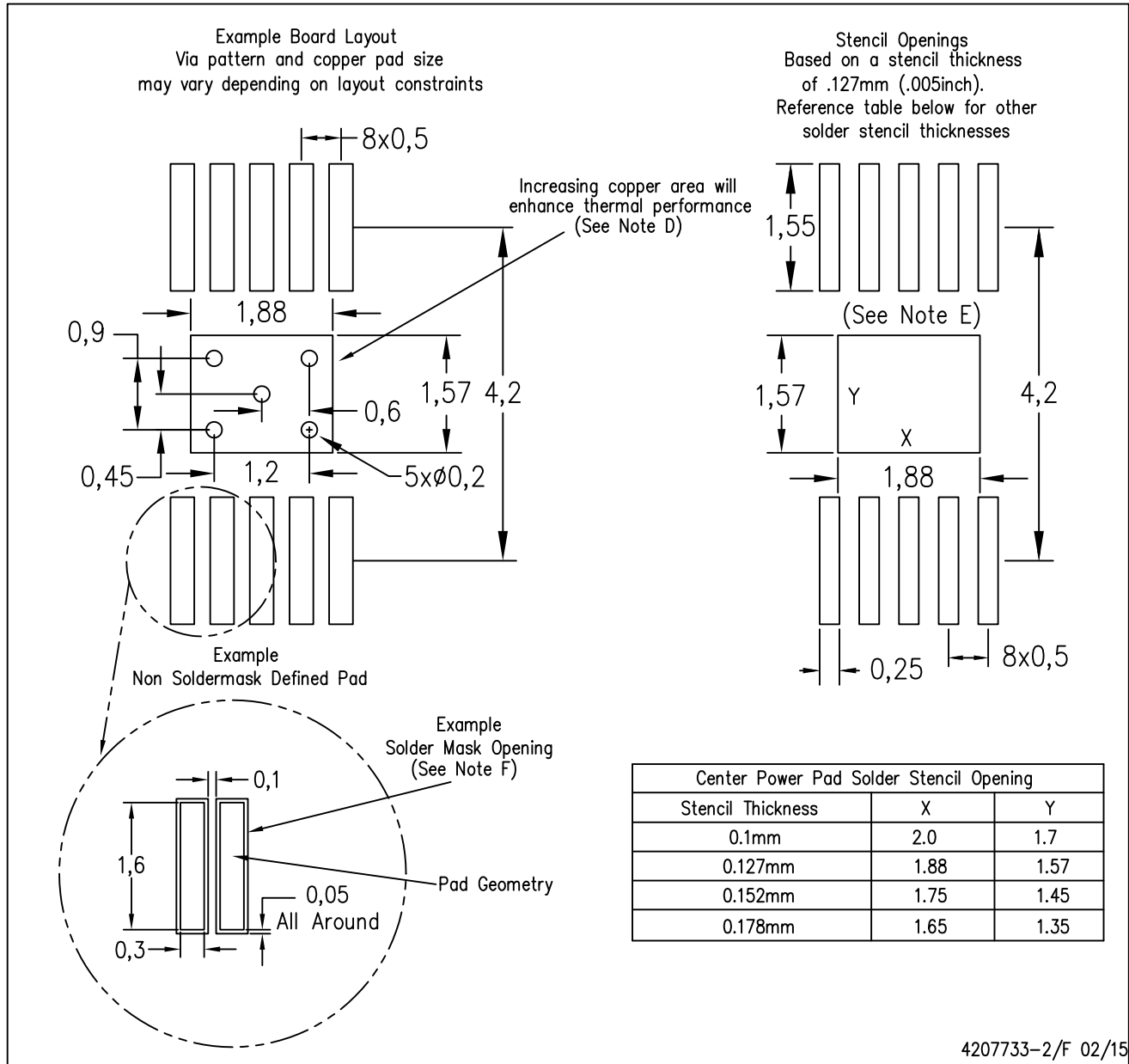

- NOTES:
- All linear dimensions are in millimeters.
 - This drawing is subject to change without notice.
 - Customers should place a note on the circuit board fabrication drawing not to alter the center solder mask defined pad.
 - This package is designed to be soldered to a thermal pad on the board. Refer to Technical Brief, PowerPad Thermally Enhanced Package, Texas Instruments Literature No. SLMA002, SLMA004, and also the Product Data Sheets for specific thermal information, via requirements, and recommended board layout. These documents are available at www.ti.com <<http://www.ti.com>>. Publication IPC-7351 is recommended for alternate designs.
 - Laser cutting apertures with trapezoidal walls and also rounding corners will offer better paste release. Customers should contact their board assembly site for stencil design recommendations. Example stencil design based on a 50% volumetric metal load solder paste. Refer to IPC-7525 for other stencil recommendations.
 - Customers should contact their board fabrication site for solder mask tolerances between and around signal pads.

PowerPAD is a trademark of Texas Instruments

DGQ (S-PDSO-G10)

PowerPAD™ PLASTIC SMALL OUTLINE

THERMAL INFORMATION

This PowerPAD™ package incorporates an exposed thermal pad that is designed to be attached to a printed circuit board (PCB). The thermal pad must be soldered directly to the PCB. After soldering, the PCB can be used as a heatsink. In addition, through the use of thermal vias, the thermal pad can be attached directly to the appropriate copper plane shown in the electrical schematic for the device, or alternatively, can be attached to a special heatsink structure designed into the PCB. This design optimizes the heat transfer from the integrated circuit (IC).

For additional information on the PowerPAD package and how to take advantage of its heat dissipating abilities, refer to Technical Brief, PowerPAD Thermally Enhanced Package, Texas Instruments Literature No. SLMA002 and Application Brief, PowerPAD Made Easy, Texas Instruments Literature No. SLMA004. Both documents are available at www.ti.com.

The exposed thermal pad dimensions for this package are shown in the following illustration.

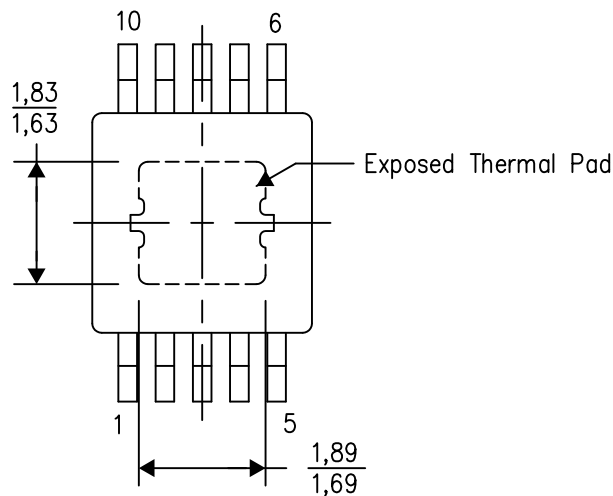

Top View

Exposed Thermal Pad Dimensions

4206324-7/H 12/14

NOTE: A. All linear dimensions are in millimeters

PowerPAD is a trademark of Texas Instruments

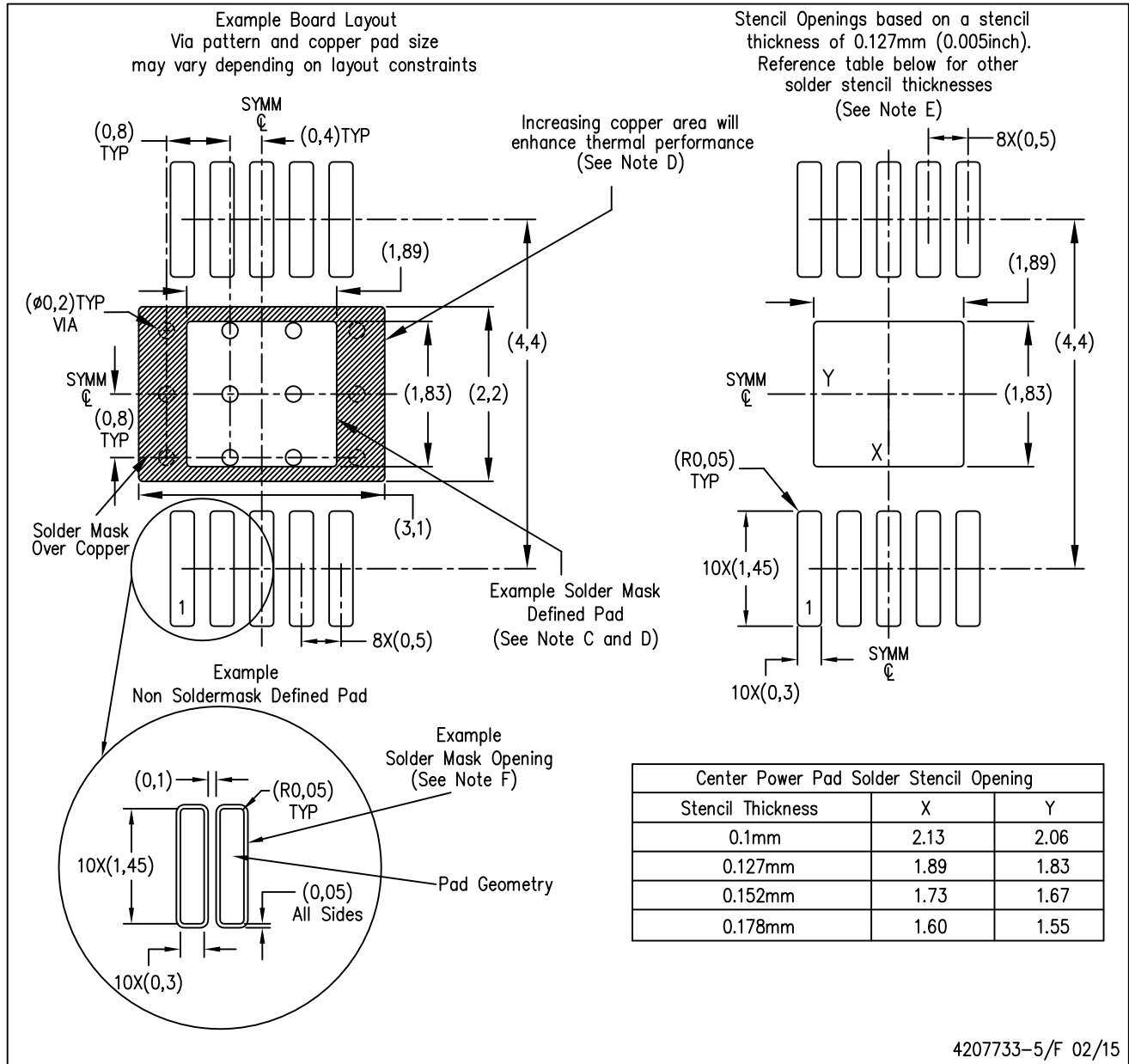

- NOTES:
- A. All linear dimensions are in millimeters.
 - B. This drawing is subject to change without notice.
 - C. Customers should place a note on the circuit board fabrication drawing not to alter the center solder mask defined pad.
 - D. This package is designed to be soldered to a thermal pad on the board. Refer to Technical Brief, PowerPAD Thermally Enhanced Package, Texas Instruments Literature No. SLMA002, SLMA004, and also the Product Data Sheets for specific thermal information, via requirements, and recommended board layout. These documents are available at www.ti.com <<http://www.ti.com>>. Publication IPC-7351 is recommended for alternate designs.
 - E. Laser cutting apertures with trapezoidal walls and also rounding corners will offer better paste release. Customers should contact their board assembly site for stencil design recommendations. Example stencil design based on a 50% volumetric metal load solder paste. Refer to IPC-7525 for other stencil recommendations.
 - F. Customers should contact their board fabrication site for solder mask tolerances between and around signal pads.

PowerPAD is a trademark of Texas Instruments

IMPORTANT NOTICE AND DISCLAIMER

TI PROVIDES TECHNICAL AND RELIABILITY DATA (INCLUDING DATASHEETS), DESIGN RESOURCES (INCLUDING REFERENCE DESIGNS), APPLICATION OR OTHER DESIGN ADVICE, WEB TOOLS, SAFETY INFORMATION, AND OTHER RESOURCES "AS IS" AND WITH ALL FAULTS, AND DISCLAIMS ALL WARRANTIES, EXPRESS AND IMPLIED, INCLUDING WITHOUT LIMITATION ANY IMPLIED WARRANTIES OF MERCHANTABILITY, FITNESS FOR A PARTICULAR PURPOSE OR NON-INFRINGEMENT OF THIRD PARTY INTELLECTUAL PROPERTY RIGHTS.

These resources are intended for skilled developers designing with TI products. You are solely responsible for (1) selecting the appropriate TI products for your application, (2) designing, validating and testing your application, and (3) ensuring your application meets applicable standards, and any other safety, security, or other requirements. These resources are subject to change without notice. TI grants you permission to use these resources only for development of an application that uses the TI products described in the resource. Other reproduction and display of these resources is prohibited. No license is granted to any other TI intellectual property right or to any third party intellectual property right. TI disclaims responsibility for, and you will fully indemnify TI and its representatives against, any claims, damages, costs, losses, and liabilities arising out of your use of these resources.

TI's products are provided subject to TI's Terms of Sale (www.ti.com/legal/termsofsale.html) or other applicable terms available either on ti.com or provided in conjunction with such TI products. TI's provision of these resources does not expand or otherwise alter TI's applicable warranties or warranty disclaimers for TI products.

Mailing Address: Texas Instruments, Post Office Box 655303, Dallas, Texas 75265
Copyright © 2019, Texas Instruments Incorporated

Looking for pricing, stock, or lifecycle information?

Click below to explore more details on WIN SOURCE:

 [View BQ24095DGQT on WIN SOURCE](#)

 [Texas Instruments](#) Information

Optimize Your Supply Chain with WIN SOURCE Solutions

-  Global Sourcing Solution
-  Obsolete Management
-  Cost Control Management
-  Shortage Management
-  Alternative Solution
-  Excess Inventory Management