



**THE DATASHEET OF
TS5USBA43402YZPR**



SP3T SWITCH WITH IMPEDANCE DETECTION MICRO-USB SWITCH TO SUPPORT USB, UART, AUDIO, AND CHARGER

Check for Samples: [TS5USBA43402](#)

FEATURES

- **Compatible Accessories**
 - USB Data Cable
 - UART Cable
 - Charger (Dedicated Charger or Host/Hub Charger)
 - Stereo Headset With Mic
- **Integrated LDOs for V_{REF} and Mic Bias**
- **USB Path Supports USB 2.0 High Speed**
- **Audio Path Provides Negative Rail Support and Click/Pop Reduction**
- **Supports Factory Test Mode**
- **1.8-V Compatible I²C Interface**
- **ESD Performance Tested Per JESD 22**
 - 2000-V Human-Body Model (A114-B, Class II)
 - 1000-V Charged-Device Model (C101)

- **ESD Performance DP/DM/ID/ V_{BUS} to GND**
 - ± 8 -kV Contact Discharge (IEC 61000-4-2)
 - ± 15 -kV Air Gap Discharge (IEC 61000-4-2)

APPLICATIONS

- Cellular Telephones

**YZP PACKAGE
(LASER SCRIBE VIEW)**

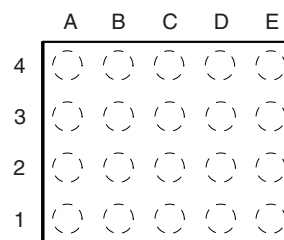

PIN ASSIGNMENTS

	A	B	C	D	E
4	MIC	ISET	UART_TX	USB_DM	USB_DP
3	R2.2K	$\overline{\text{INT}}$	UART_RX	ID	DP
2	SDA	SCL	DSS	GND	DM
1	CLDO	V_{SUPPLY}	AUDIO_R	AUDIO_L	V_{BUS}

DESCRIPTION

The TS5USBA43402 is designed to interface the cellphone UART, USB, and audio chips with external peripherals via a micro-USB connector. The switch features impedance detection for identification of various accessories that are attached through DP and DM of the micro-USB port. When an accessory is plugged into the micro-USB port, the switch uses a detection mechanism to identify the accessory (see [State Machine](#) for details). It will then switch to the appropriate channel—data, audio, or UART.

The TS5USBA43402 has an I²C interface for communication with the cellphone baseband or applications processor. An interrupt is generated when anything plugged into the micro-USB is detected. Another interrupt is generated when the device is unplugged.

Table 1. ORDERING INFORMATION

T_A	PACKAGE ^{(1) (2)}		ORDERABLE PART NUMBER	TOP-SIDE MARKING
–40°C to 85°C	WSCP – YZP (0.5-mm pitch)	Tape and reel	TS5USBA43402YZPR	5F2

(1) Package drawings, thermal data, and symbolization are available at www.ti.com/packaging.

(2) For the most current package and ordering information, see the Package Option Addendum at the end of this document, or see the TI Web site at www.ti.com.



Please be aware that an important notice concerning availability, standard warranty, and use in critical applications of Texas Instruments semiconductor products and disclaimers thereto appears at the end of this data sheet.

Table 2. SUMMARY OF CHARACTERISTICS

T_A = 25°C

	USB PATH	UART PATH	AUDIO PATH	MIC PATH
Number of switches	2	2	2	1
ON-state resistance (r _{ON})	5 Ω	37 Ω	3 Ω	8.8 Ω
ON-state resistance match (Δr _{ON})	1 Ω	3 Ω	1.1 Ω	N/A
ON-state resistance flatness (r _{ON(flat)})	0.24 Ω	14 Ω	0.1 Ω	0.5 Ω
Turn-on/turn-off time (t _{ON} /t _{OFF})	1 ms	1 ms	1 ms	1 ms
Bandwidth (BW)	>720 MHz	>300 MHz	>900 MHz	>67 MHz
OFF isolation (O _{ISO})	-22 dB	-40 dB	-75 dB	-100 dB
Crosstalk (X _{TALK})	-40 dB	-40 dB	-50 dB	-50 dB
Total harmonic distortion (THD)	N/A	N/A	0.05%	0.0017%
Leakage current (I _{NO(OFF)} /I _{NC(OFF)})	100 nA	100 nA	100 nA	100 nA
Package options	YZP package, 0.5-mm pitch			

BLOCK DIAGRAM

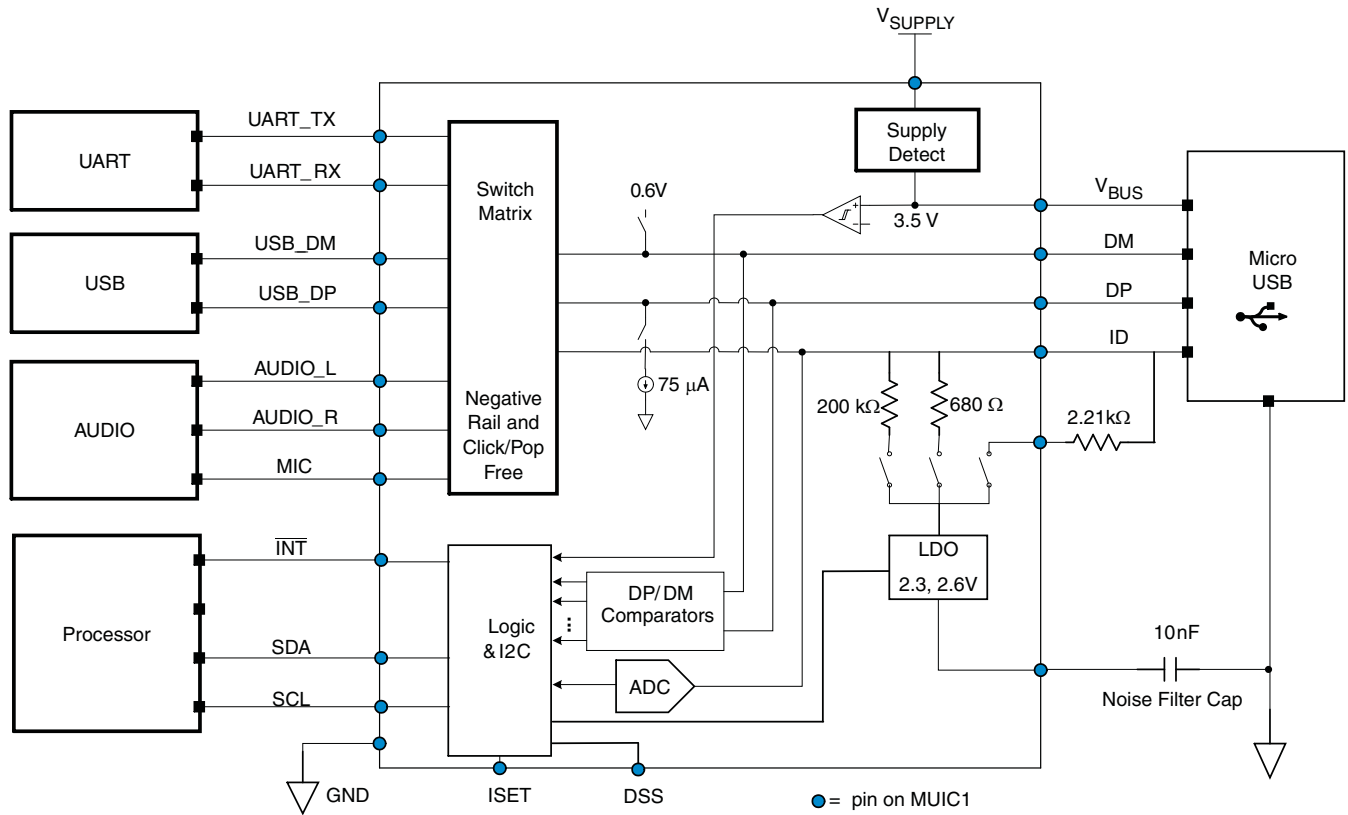

SWITCH MATRIX BLOCK DIAGRAM

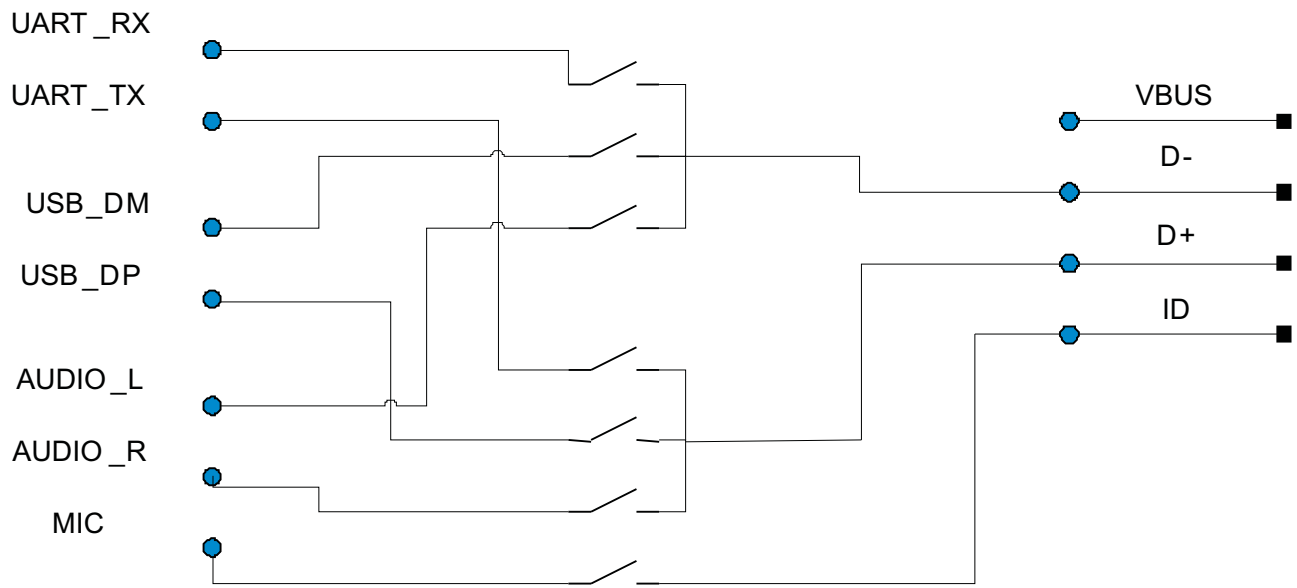

TERMINAL FUNCTIONS

TERMINAL		TYPE	DESCRIPTION
NAME	NO.		
AUDIO_L	D1	I/O	Stereo audio left channel
AUDIO_R	C1	I/O	Stereo audio right channel
CLDO	A1	O	Capacitor connection for LDO noise filtering
DM	E2	I/O	Common I/O port for USB, UART, Audio. Connected to USB receptacle.
DP	E3	I/O	Common I/O port for USB, UART, Audio. Connected to USB receptacle.
DSS	C2	I	Pulldown or pullup resistor connection to determine default switch
GND	D2	GND	Ground
ID	D3	I/O	Common I/O port for microphone, ID detection
$\overline{\text{INT}}$	B3	O	Open-drain interrupt output. Connect an external pullup resistor.
ISSET	B4	O	Output to charger for high-current charging mode. Open-drain output.
MIC	A4	I/O	Microphone signal
R2.2K	A3	I	2.21 k Ω connection for microphone bias
SCL	B2	I	I ² C clock input. Connect an external pullup resistor.
SDA	A2	I/O	I ² C data. Connect an external pullup resistor.
UART_RX	C3	I/O	UART receive data
UART_TX	C4	I/O	UART transmit data
USB_DM	D4	I/O	USB D– connected to host
USB_DP	E4	I/O	USB D+ connected to host
V _{BUS}	E1	I	V _{BUS} power supply from USB receptacle
V _{SUPPLY}	B1	I	2.8-V to 4.4-V battery supply voltage

ABSOLUTE MAXIMUM RATINGS^{(1) (2)}

over operating free-air temperature range (unless otherwise noted)

		MIN	MAX	UNIT	
V _{BUS}	Supply voltage from USB connector	-0.5	28	V	
V _{SUPPLY}	Supply voltage from battery	-0.5	6	V	
V _{USBIO}	Switch I/O voltage range	USB switch	-0.5	V _{SUPPLY} +0.5	V
V _{UARTIO}		UART switch	-0.5	V _{SUPPLY} +0.5	V
V _{AUDIO}		Audio switch	-1.5	V _{SUPPLY} +0.5	V
V _{MICIO}		Mic switch	-0.5	V _{SUPPLY} +0.5	
V _{LOGICIO}	Logic input, output and I/O voltage ranges	DSS, SCL, SDA	-0.5	V _{SUPPLY} +0.5	V
I _{BUS}	Input current on V _{BUS} pin		100	mA	
I _{SUPPLY}	Input current on V _{SUPPLY} pin		100	mA	
I _{GND}	Continuous current through GND		100	mA	
I _K	Analog port diode current	-50	50	mA	
I _{SW-DC}	ON-state continuous switch current	-60	60	mA	
I _{SW-PEAK}	ON-state peak switch current	-150	150	mA	
I _{IK}	Digital logic input clamp current	V _L < 0	-50	mA	
I _{LOGIC_O}	Continuous current through logic output		50	mA	
T _{stg}	Storage temperature range	-65	150	°C	

- (1) Stresses above these ratings may cause permanent damage. Exposure to absolute maximum conditions for extended periods may degrade device reliability. These are stress ratings only, and functional operation of the device at these or any other conditions beyond those specified is not implied.
- (2) The algebraic convention, whereby the most negative value is a minimum and the most positive value is a maximum.

THERMAL IMPEDANCE RATINGS

		UNIT		
θ _{JA}	Package thermal impedance	YZP package	75.5	°C/W

RECOMMENDED OPERATING CONDITIONS

		MIN	MAX	UNIT	
V _{BUS}	Supply voltage from USB connector	4.35	6.7	V	
V _{SUPPLY}	Supply voltage from battery	2.8	4.4	V	
V _{USBIO}	Switch I/O voltage range	USB switch	0	3.6	V
V _{UARTIO}		UART switch	0	V _{SUPPLY}	
V _{AUDIO}		Audio switch	-1.3	1.3	
V _{MICIO}		Mic switch	0	2.3	
V _{LOGICIO}	Logic input, output and I/O voltage ranges	DSS, SCL, SDA	0	V _{SUPPLY}	V
I _{SW-DC}	ON-state continuous switch current			mA	
I _{SWPEAK}	ON-state peak switch current			mA	
T _A	Ambient temperature	-40	85	°C	

ELECTRICAL CHARACTERISTICS

$T_A = -40^{\circ}\text{C}$ to 85°C , typical values are at $V_{\text{SUPPLY}} = 3.6\text{ V}$, $V_{\text{BUS}} = 5\text{ V}$, $T_A = 25^{\circ}\text{C}$ (unless otherwise noted)

PARAMETER	SYMBOL	TEST CONDITIONS	MIN	TYP	MAX	UNIT
V_{SUPPLY} supply current	I_{VSUPPLY}	$V_{\text{SUPPLY}} = 4.2\text{ V}$, $V_{\text{BUS}} = 0\text{ V}$, $\text{ADC_EN} = 0$,	$\text{CP_EN} = 0$, $\text{SEMREN} = 0$	6	10	μA
			$\text{CP_EN} = 0$, $\text{SEMREN} = 1$	6	10	
			$\text{CP_EN} = 1$, $\text{SEMREN} = 1$	60	70	
V_{BUS} supply current	I_{VBUS}	$V_{\text{SUPPLY}} = 3.6\text{ V}$, $V_{\text{BUS}} = 5\text{ V}$, $\text{ADC_EN} = 0$,	$\text{CP_EN} = 0$, $\text{SEMREN} = 0$	45	60	μA
			$\text{CP_EN} = 0$, $\text{SEMREN} = 1$	45	60	
			$\text{CP_EN} = 1$, $\text{SEMREN} = 1$	80	98	
V_{BUS} detect threshold	V_{BUSDET}	$V_{\text{BUS}} = 0$ to 5 V , read the INT	3	3.5	4	V
Microphone removal threshold	V_{MRCOMP}	Ramp ID down, read the INT	LDO voltage = 2.6 V	2.2		V
			LDO voltage = 2.3 V	1.95		
SEND/END threshold	V_{SECOMP}	LDO voltage = 2.3 or 2.6 V , ramp ID up from 0 V , read the INT	0.15			V
ID resistance 1	R_{ID1}	$\text{ID_200} = 1$, $V_{\text{SUPPLY}} = 3.6\text{ V}$	160	200	240	$\text{k}\Omega$
ID resistance 2	R_{ID2}	$\text{ID_620} = 1$, $V_{\text{SUPPLY}} = 3.6\text{ V}$	496	620	744	Ω

LDO ELECTRICAL CHARACTERISTICS

$T_A = -40^{\circ}\text{C}$ to 85°C , typical values are at $V_{\text{SUPPLY}} = 3.6\text{ V}$, $V_{\text{BUS}} = 5\text{ V}$, $T_A = 25^{\circ}\text{C}$ (unless otherwise noted)

PARAMETER	SYMBOL	TEST CONDITIONS	MIN	TYP	MAX	UNIT	
Input voltage	V_{BUS}		4.35	5	6.7	V	
	V_{SUPPLY}		2.8		4.4		
Output voltage	$V_{\text{OUT-26}}$	$I_{\text{O}} = 0\text{ mA}$	2.54	2.6	2.65	V	
	$V_{\text{OUT-23}}$		2.2	2.3	2.35		
Max output current	$I_{\text{O-26}}$	Measured at R2.2K pin			10	μA	
	$I_{\text{O-23}}$				500		
Power supply rejection	PSR_{217}	$V_{\text{OUT}} = 2.3\text{ V}$, $V_{\text{SUPPLY}} = 3.2\text{ V}$, $I_{\text{O}} = 150$ to $450\text{ }\mu\text{A}$,	$f = 217\text{ Hz}$	-50		dB	
	PSR_{1k}		$f = 1\text{ kHz}$	-42			
Integrated output noise	$e_{\text{n-OUT}}$	$V_{\text{OUT}} = 2.3\text{ V}$, $V_{\text{SUPPLY}} = 3.2\text{ V}$, $I_{\text{O}} = 150$ to $450\text{ }\mu\text{A}$,	$f = 20\text{ Hz}$ to 20 kHz (A-weighted)		1	50	μV
Rise time 1	t_{r1}	$I_{\text{O}} = 20\text{ }\mu\text{A}$, R2.2K = 0 to 2.6 V			178	ms	
Rise time 2	t_{r2}	$I_{\text{O}} = 20\text{ }\mu\text{A}$, R2.2K = 2.3 to 2.6 V			260	ms	
Fall time	t_{f}	$I_{\text{O}} = 0\text{ }\mu\text{A}$, R2.2K = 2.6 to 2.3 V			2.5	ms	

USB SWITCH ELECTRICAL CHARACTERISTICS FOR 2.8 V to 4.4 V SUPPLY
 $T_A = -40^\circ\text{C}$ to 85°C , typical values are at $V_{\text{SUPPLY}} = 3.6\text{ V}$, $V_{\text{BUS}} = 5\text{ V}$, $T_A = 25^\circ\text{C}$ (unless otherwise noted)

PARAMETER	SYMBOL	TEST CONDITIONS		MIN	TYP	MAX	UNIT
Analog Switch							
Analog signal range	V_{USBIO}			0		3.6	V
ON-state resistance	r_{ON}	$V_I = 0\text{ V to }3.6\text{ V}$, $I_O = -2\text{ mA}$,	$V_{\text{SUPPLY}} = 3.0\text{ V}$, $\text{CP_EN} = 1$, Switch ON		4.5	10	Ω
ON-state resistance match between channels	Δr_{ON}	$V_I = 0.4\text{ V}$, $I_O = -2\text{ mA}$,	$V_{\text{SUPPLY}} = 3.0\text{ V}$, $\text{CP_EN} = 1$, Switch ON		1	1.5	Ω
ON-state resistance flatness	$r_{\text{ON(flat)}}$	$V_I = 0\text{ V to }3.6\text{ V}$, $I_O = -2\text{ mA}$, $V_{\text{SUPPLY}} = 3.0\text{ V}$	$\text{CP_EN} = 1$, Switch ON		0.5	1	Ω
V_I or V_O OFF leakage current ⁽¹⁾	$I_{\text{IO(OFF)}}$	$V_I = 0.3\text{ V}$, $V_O = 2.5\text{ V}$ or $V_I = 2.5\text{ V}$, $V_O = 0.3\text{ V}$,	$V_{\text{SUPPLY}} = 4.4\text{ V}$, Switch OFF		25	360	nA
V_O ON leakage current ⁽¹⁾	$I_{\text{IO(ON)}}$	$V_I = \text{OPEN}$, $V_O = 0.3\text{ V}$ or 2.5 V ,	$V_{\text{SUPPLY}} = 4.4\text{ V}$, $\text{CP_EN} = 1$, Switch ON		10	360	nA
Dynamic							
Turn-ON time	t_{ON}	V_I or $V_O = V_{\text{SUPPLY}}$, $R_L = 50\ \Omega$, $C_L = 35\text{ pF}$	$\text{CP_EN} = 1$ From receipt of I ² C ACK bit		1		ms
Turn-OFF time	t_{OFF}	V_I or $V_O = V_{\text{SUPPLY}}$, $R_L = 50\ \Omega$, $C_L = 35\text{ pF}$,	$\text{CP_EN} = 0$ From receipt of I ² C ACK bit		1		ms
V_I OFF capacitance ⁽¹⁾	$C_{\text{I(OFF)}}$	DC bias = 0 V or 3.6 V $f = 10\text{ MHz}$,	$\text{CP_EN} = 0$, Switch OFF		6.5		pF
V_O OFF capacitance ⁽¹⁾	$C_{\text{O(OFF)}}$	DC bias = 0 V or 3.6 V $f = 10\text{ MHz}$,	$\text{CP_EN} = 0$, Switch OFF		3		pF
V_I , V_O ON capacitance ⁽¹⁾	$C_{\text{I(ON)}}$, $C_{\text{O(ON)}}$	DC bias = 0 V or 3.6 V $f = 10\text{ MHz}$,	$\text{CP_EN} = 1$, Switch ON		9		pF
Bandwidth	BW	$R_L = 50\ \Omega$,	$\text{CP_EN} = 1$, Switch ON		830		MHz
OFF Isolation	O_{ISO}	$f = 240\text{ MHz}$, $R_L = 50\ \Omega$, $C_L = 20\text{ pF}$,	$\text{CP_EN} = 0$, Switch OFF		-20		dB
Crosstalk	X_{TALK}	$f = 240\text{ MHz}$, $R_L = 50\ \Omega$, $C_L = 20\text{ pF}$,	$\text{CP_EN} = 1$, Switch ON		-42		dB

(1) V_I = voltage asserted on DP and DM pins. V_O = voltage asserted on USB_DP and USB_DM pins. I_O = current on the USB_DP or USB_DM pins.

UART SWITCH ELECTRICAL CHARACTERISTICS FOR 2.8 V to 4.4 V SUPPLY

$T_A = -40^\circ\text{C}$ to 85°C , typical values are at $V_{\text{SUPPLY}} = 3.6\text{ V}$, $V_{\text{BUS}} = 5\text{ V}$, $T_A = 25^\circ\text{C}$ (unless otherwise noted)

PARAMETER	SYMBOL	TEST CONDITIONS		MIN	TYP	MAX	UNIT
Analog Switch							
Analog signal range	V_{UARTIO}			0		V_{SUPPLY}	V
ON-state resistance	r_{ON}	$V_I = 0\text{ V to } 2.8\text{ V}$, $I_O = -2\text{ mA}$,	$V_{\text{SUPPLY}} = 2.8\text{ V}$, $\text{CP_EN} = 1$, Switch ON		37	61	Ω
ON-state resistance match between channels	Δr_{ON}	$V_I = 0.4\text{ V}$, $I_O = -2\text{ mA}$,	$V_{\text{SUPPLY}} = 2.8\text{ V}$, Switch ON		2	3.5	Ω
ON-state resistance flatness	$r_{\text{ON(flat)}}$	$V_I = 0\text{ V to } 2.8\text{ V}$, $I_O = -2\text{ mA}$, $V_{\text{SUPPLY}} = 2.8\text{ V}$	Switch ON		20	27	Ω
V_I or V_O OFF leakage current ⁽¹⁾	$I_{\text{IO(OFF)}}$	$V_I = 0.3\text{ V}$, $V_O = 3.3\text{ V}$ or $V_I = 3.3\text{ V}$, $V_O = 0.3\text{ V}$,	$V_{\text{SUPPLY}} = 3.6\text{ V}$, Switch OFF		100	360	nA
V_O ON leakage current ⁽¹⁾	$I_{\text{IO(ON)}}$	$V_I = \text{OPEN}$, $V_O = 0.3\text{ V}$ or 3.3 V ,	$V_{\text{SUPPLY}} = 3.6\text{ V}$, $\text{CP_EN} = 1$, Switch ON		100	360	nA
Dynamic							
Turn-ON time	t_{ON}	V_I or $V_O = V_{\text{SUPPLY}}$, $R_L = 50\ \Omega$, $C_L = 35\text{ pF}$	From receipt of I ² C ACK bit		1		ms
Turn-OFF time	t_{OFF}	V_I or $V_O = V_{\text{SUPPLY}}$, $R_L = 50\ \Omega$, $C_L = 35\text{ pF}$	From receipt of I ² C ACK bit		1		ms
V_I OFF capacitance ⁽¹⁾	$C_{\text{I(OFF)}}$	DC bias = 0 V or V_{SUPPLY} , $f = 10\text{ MHz}$,	Switch OFF		6.5		pF
V_O OFF capacitance ⁽¹⁾	$C_{\text{O(OFF)}}$	DC bias = 0 V or V_{SUPPLY} , $f = 10\text{ MHz}$,	Switch OFF		8		pF
V_I , V_O ON capacitance ⁽¹⁾	$C_{\text{I(ON)}}$, $C_{\text{O(ON)}}$	DC bias = 0 V or V_{SUPPLY} , $f = 10\text{ MHz}$,	Switch ON		22		pF
Bandwidth	BW	$R_L = 50\ \Omega$,	Switch ON		295		MHz
OFF Isolation	O_{ISO}	$f = 250\text{ kHz}$, $R_L = 50\ \Omega$, $C_L = 20\text{ pF}$,	Switch OFF		-100		dB
Crosstalk	X_{TALK}	$f = 250\text{ kHz}$, $R_L = 50\ \Omega$, $C_L = 20\text{ pF}$,	Switch ON		-98		dB

(1) V_I = voltage asserted on DP and DM pins. V_O = voltage asserted on UART_RX and UART_TX pins. I_O = current on the UART_RX and UART_TX pins.

AUDIO SWITCH ELECTRICAL CHARACTERISTICS FOR 2.8 V to 4.4 V SUPPLY
 $T_A = -40^{\circ}\text{C}$ to 85°C , typical values are at $V_{\text{SUPPLY}} = 3.6\text{ V}$, $V_{\text{BUS}} = 5\text{ V}$, $T_A = 25^{\circ}\text{C}$ (unless otherwise noted)

PARAMETER	SYMBOL	TEST CONDITIONS		MIN	TYP	MAX	UNIT
Analog Switch							
Analog signal range	V_{AUDIOIO}			-1.3		1.3	V
ON-state resistance	r_{ON}	$V_I = \pm 1.3\text{ V}$, $I_O = -20\text{ mA}$, $V_{\text{SUPPLY}} = 2.8\text{ V}$,	AUDIO_L or AUDIO_R, DM or DP		3.8	6	Ω
ON-state resistance match between channels	Δr_{ON}	$V_I = 1.3\text{ V}$, $I_O = -20\text{ mA}$, $V_{\text{SUPPLY}} = 2.8\text{ V}$,	AUDIO_L or AUDIO_R, DM or DP		1	1.3	Ω
ON-state resistance flatness	$r_{\text{ON(flat)}}$	$V_I = \pm 1.3\text{ V}$, $I_O = -20\text{ mA}$, $V_{\text{SUPPLY}} = 2.8\text{ V}$,	AUDIO_L or AUDIO_R, DM or DP		0.1	0.25	Ω
V_I or V_O OFF leakage current ⁽¹⁾	$I_{\text{IO(OFF)}}$	$V_I = 0\text{ V}$, $V_O = 1.3\text{ V}$ or $V_I = 1.3\text{ V}$, $V_O = 0.3\text{ V}$,	Switch OFF		25	400	nA
V_O ON leakage current ⁽¹⁾	$I_{\text{IO(ON)}}$	$V_I = \text{OPEN}$, $V_O = \pm 1.3\text{ V}$, $V_{\text{SUPPLY}} = 4.4\text{ V}$,	Switch ON		25	400	nA
Dynamic							
Turn-ON time	t_{ON}	V_I or $V_O = V_{\text{SUPPLY}}$, $R_L = 50\ \Omega$, $C_L = 35\text{ pF}$	From receipt of I ² C ACK bit		1		ms
Turn-OFF time	t_{OFF}	V_I or $V_O = V_{\text{SUPPLY}}$, $R_L = 50\ \Omega$, $C_L = 35\text{ pF}$	From receipt of I ² C ACK bit		1		ms
V_I OFF capacitance ⁽¹⁾	$C_{\text{I(OFF)}}$	DC bias = 0 V or 2.6 V, $f = 10\text{ MHz}$,	Switch OFF		4.5		pF
V_O OFF capacitance ⁽¹⁾	$C_{\text{O(OFF)}}$	DC bias = 0 V or 2.6 V, $f = 10\text{ MHz}$,	Switch OFF		6.5		pF
V_I , V_O ON capacitance ⁽¹⁾	$C_{\text{I(ON)}}$, $C_{\text{O(ON)}}$	DC bias = 0 V or 2.6 V, $f = 10\text{ MHz}$,	Switch ON		9		pF
Bandwidth	BW	$R_L = 50\ \Omega$,	Switch ON		788		MHz
OFF Isolation	O_{ISO}	$f = 20\text{ kHz}$, $R_L = 50\ \Omega$,	Switch OFF		-100		dB
Crosstalk	X_{TALK}	$f = 20\text{ kHz}$, $R_L = 50\ \Omega$,	Switch ON		-120		dB
Total harmonic distortion	THD	$R_L = 16\ \Omega$, $C_L = 20\text{ pF}$,	$f = 20\text{ Hz}$ to 20 kHz , 2.6 Vpp		0.087	0.12	%

(1) V_O = voltage asserted on DP and DM pins. V_I = voltage asserted on AUDIO_R and AUDIO_L pins. I_O = current on the DP and DM pins.

MIC SWITCH ELECTRICAL CHARACTERISTICS FOR 2.8 V to 4.4 V SUPPLY

$T_A = -40^\circ\text{C}$ to 85°C , typical values are at $V_{\text{SUPPLY}} = 3.6\text{ V}$, $V_{\text{BUS}} = 5\text{ V}$, $T_A = 25^\circ\text{C}$ (unless otherwise noted)

PARAMETER	SYMBOL	TEST CONDITIONS	MIN	TYP	MAX	UNIT
Analog Switch						
Analog signal range	V_{MICIO}		0		2.3	V
ON-state resistance	r_{ON}	$V_I = 2.3\text{ V}$, $I_O = -2\text{ mA}$, $V_{\text{SUPPLY}} = 2.8\text{ V}$, MIC ID		9	12	Ω
ON-state resistance flatness	$r_{\text{ON(Flat)}}$	$V_I = 2.3\text{ V}$, $I_O = -2\text{ mA}$, $V_{\text{SUPPLY}} = 2.8\text{ V}$ MIC ID		0.5	1	Ω
V_I or V_O OFF leakage current ⁽¹⁾	$I_{\text{O(OFF)}}$	$V_I = 0.3\text{ V}$, $V_O = 2.3\text{ V}$ or $V_I = 2.3\text{ V}$, $V_O = 0.3\text{ V}$, $V_{\text{SUPPLY}} = 4.4\text{ V}$ Switch OFF		5	200	nA
V_O ON leakage current ⁽¹⁾	$I_{\text{O(ON)}}$	$V_I = \text{OPEN}$ $V_O = 0.3\text{ V}$ or 2.5 V $V_{\text{SUPPLY}} = 4.4\text{ V}$ Switch ON		2	200	nA
Dynamic						
Turn-ON time	t_{ON}	V_I or $V_O = V_{\text{SUPPLY}}$, $R_L = 50\ \Omega$, $C_L = 35\text{ pF}$ From receipt of I ² C ACK bit		1		ms
Turn-OFF time	t_{OFF}	V_I or $V_O = V_{\text{SUPPLY}}$, $R_L = 50\ \Omega$, $C_L = 35\text{ pF}$ From receipt of I ² C ACK bit		1		ms
V_I OFF capacitance ⁽¹⁾	$C_{\text{I(OFF)}}$	DC bias = 0 V or 3.6 V , $f = 10\text{ MHz}$, Switch OFF		6		pF
V_O OFF capacitance ⁽¹⁾	$C_{\text{O(OFF)}}$	DC bias = 0 V or 3.6 V , $f = 10\text{ MHz}$, Switch OFF		6		pF
V_I , V_O ON capacitance ⁽¹⁾	$C_{\text{I(ON)}}$, $C_{\text{O(ON)}}$	DC bias = 0 V or 3.6 V , $f = 10\text{ MHz}$, Switch ON		12		pF
Bandwidth	BW	$R_L = 50\ \Omega$, Switch ON		573		MHz
OFF Isolation	O_{ISO}	$f = 20\text{ kHz}$, $R_L = 50\ \Omega$, Switch OFF		-37		dB
Crosstalk	X_{TALK}	$f = 20\text{ kHz}$ to audio input, $R_L = 50\ \Omega$, Switch ON		-125		dB
Total harmonic distortion	THD	$R_L = 600\ \Omega$, $C_L = 20\text{ pF}$, $f = 20\text{ Hz}$ to 20 kHz , 2.6 Vpp Switch ON		0.07	0.075	%

(1) V_I = voltage asserted on the ID pin. V_O = voltage asserted on MIC pin. I_O = current on the MIC pin.

DIGITAL SIGNALS
 $T_A = -40^{\circ}\text{C}$ to 85°C (unless otherwise noted), typical values are at $V_{\text{SUPPLY}} = 3.6\text{ V}$, $V_{\text{BUS}} = 5\text{ V}$, $T_A = 25^{\circ}\text{C}$

PARAMETER	SYMBOL	TEST CONDITIONS	MIN	MAX	UNIT
DSS					
High-level input logic	V_{IH}		$V_{\text{SUPPLY}} \times 0.7$	V_{SUPPLY}	V
Low-level input logic	V_{IL}		0	$V_{\text{SUPPLY}} \times 0.3$	V
Input leakage current	I_{INLEAK}	$V_I = 0\text{ V}$ to V_{SUPPLY}	-1	1	μA
SCL, SDA					
High-level input logic	V_{IH}		1.4		V
Low-level input logic	V_{IL}			0.4	V
Input leakage current	I_{INLEAK}	$V_I = 0\text{ V}$ to V_{SUPPLY}	-1	1	μA
INT, ISET					
Open-drain low	V_{ODOL}	$I_{\text{ODL}} = 4\text{ mA}$		0.4	V

APPLICATION INFORMATION

Default Switch Position

The default switch state (DSS) pin determines if the USB switches or UART switches are selected at startup. An internal pulldown resistor is present on the DSS pin, which selects the USB switches as the default at start-up. If the user wants to default to the UART switches at startup, the DSS pin must be pulled high. If the user wants to disable the switches, this must be done using an I²C write to the SW_Control register after initialization is complete.

The default configuration with V_{BAT} power disables the switches. If the user wants to use the switches, this must be done using an I²C write to the SW_Control register after initialization is complete.

V _{BUS} PRESENT ON POWER UP	DSS	SWITCH STATES
Yes	OPEN / PD	USB
	PU	UART
No	x	Disable

ID Impedance Detection

The TS5USBA43402 features impedance detection for identification of various accessories that are attached to the microUSB port. Each accessory is identified by a unique resistor value on the ID pin to ground. During ID detection, the device auto-calibrates an internal current source, using an external 2.21K ±1% resistor. The current source is then applied to the ID pin while an internal voltage reference is incremented until it matches the ID pin voltage. This produces a 4-bit ADC value corresponding to the ID resistance found.

ID Resistor	Tolerance	ID No.	ADC Value
0 Ω	1%	0	0000
24 kΩ	1%	1	0001
56 kΩ	1% or 20%	2	0010
100 kΩ	1%	3	0011
130 kΩ	1%	4	0100
180 kΩ	1%	5	0101
240 kΩ	1%	6	0110
330 kΩ	1%	7	0111
430 kΩ	1%	8	1000
620 kΩ	1%	9	1001
910 kΩ	1%	10	1010
Open	N/A	11	1011

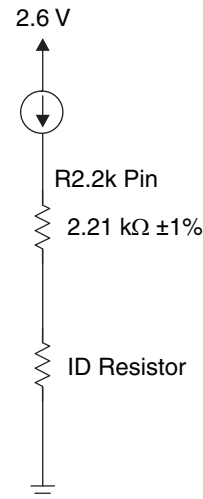

Figure 1. Figure 1. Impedance Detection Circuitry

Supply Detection

The TS5USBA43402 can be powered by either V_{SUPPLY} or V_{BUS} . The TS5USBA43402 will select V_{BUS} as the power source when present and otherwise will select V_{SUPPLY} as the power source when V_{SUPPLY} is present and V_{BUS} is not.

Supply Selection and Shutdown Sequence

	V_{SUPPLY}	HANDSET STATUS	MUIC STATUS	POWER SUPPLY
NORMAL CASE	Yes	ON	Active	V_{SUPPLY}
	Yes	OFF (S/W off)	Shutdown	
SUDDEN POWER LOSS	Yes	ON	Active	V_{SUPPLY}
	No	OFF	Shutdown	
NO BATTERY	No	OFF	Shutdown	
	No	ON (V_{BUS})	Active	V_{BUS}
USB CHARGING	Yes (charging)	ON (V_{BUS})	Active	V_{BUS}

I²C Controlled Internal Comparator Operation

Internal Comparator Logic Table

I ² C CONTROL REGISTER BIT			COMPARATORS			
USB_DET_DS	ADC_EN	SEMREN	V_{BUS}	SE	MR	LDO
0	0	0	ON	OFF	OFF	OFF
0	0	1	ON	ON	ON	ON
0	1	0	ON	OFF	ON	ON
0	1	1	ON	ON	ON	ON
1	0	0	OFF	OFF	OFF	OFF
1	0	1	ON	ON	ON	ON
1	1	0	ON	OFF	ON	ON
1	1	1	ON	ON	ON	ON

Software Flowchart

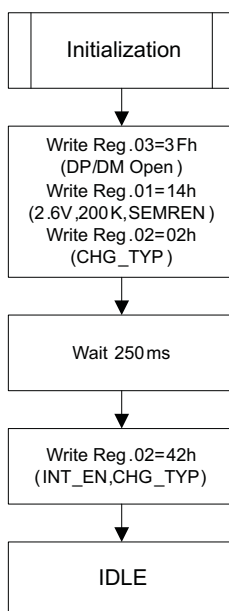

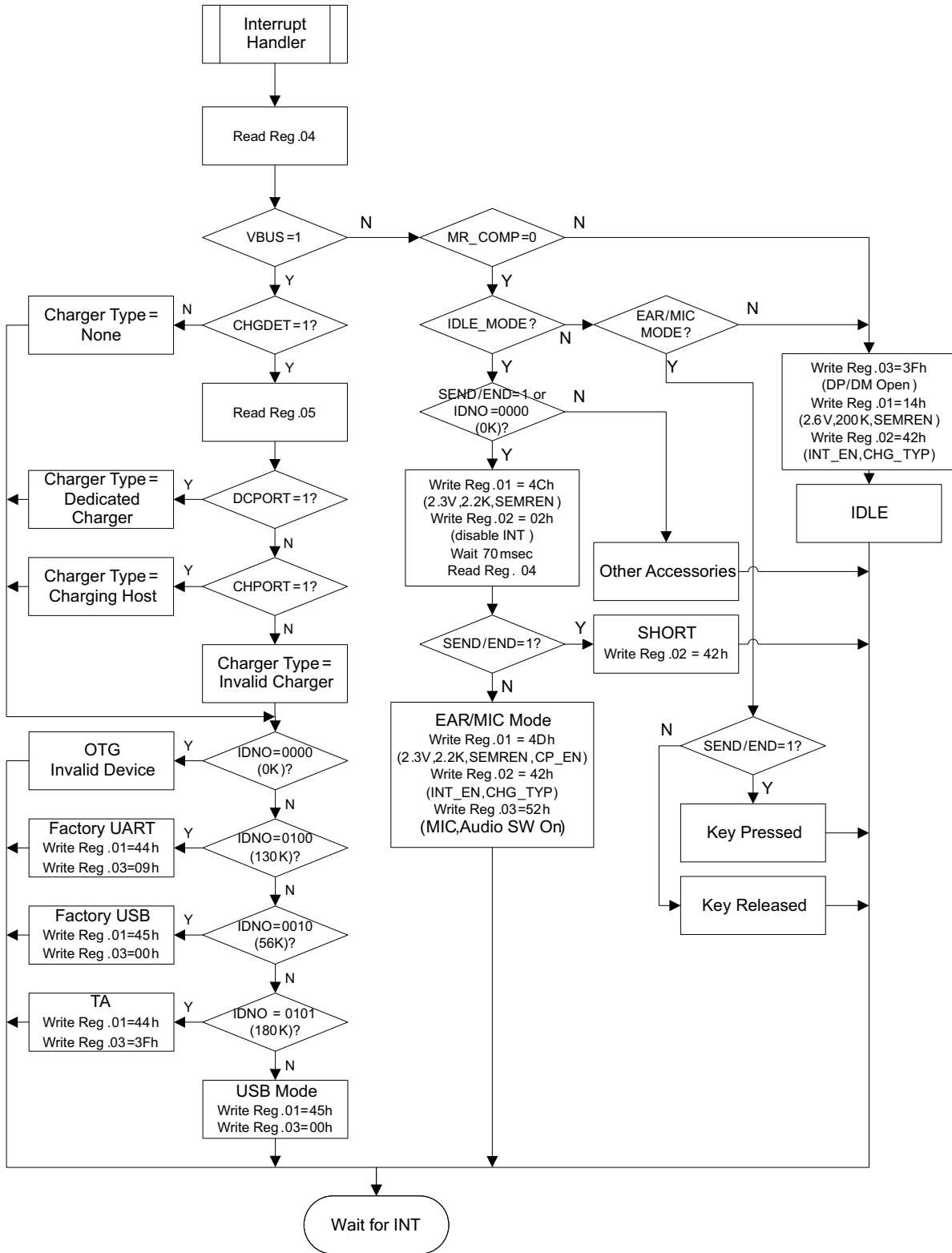

FACTORY MODE FLOWCHART

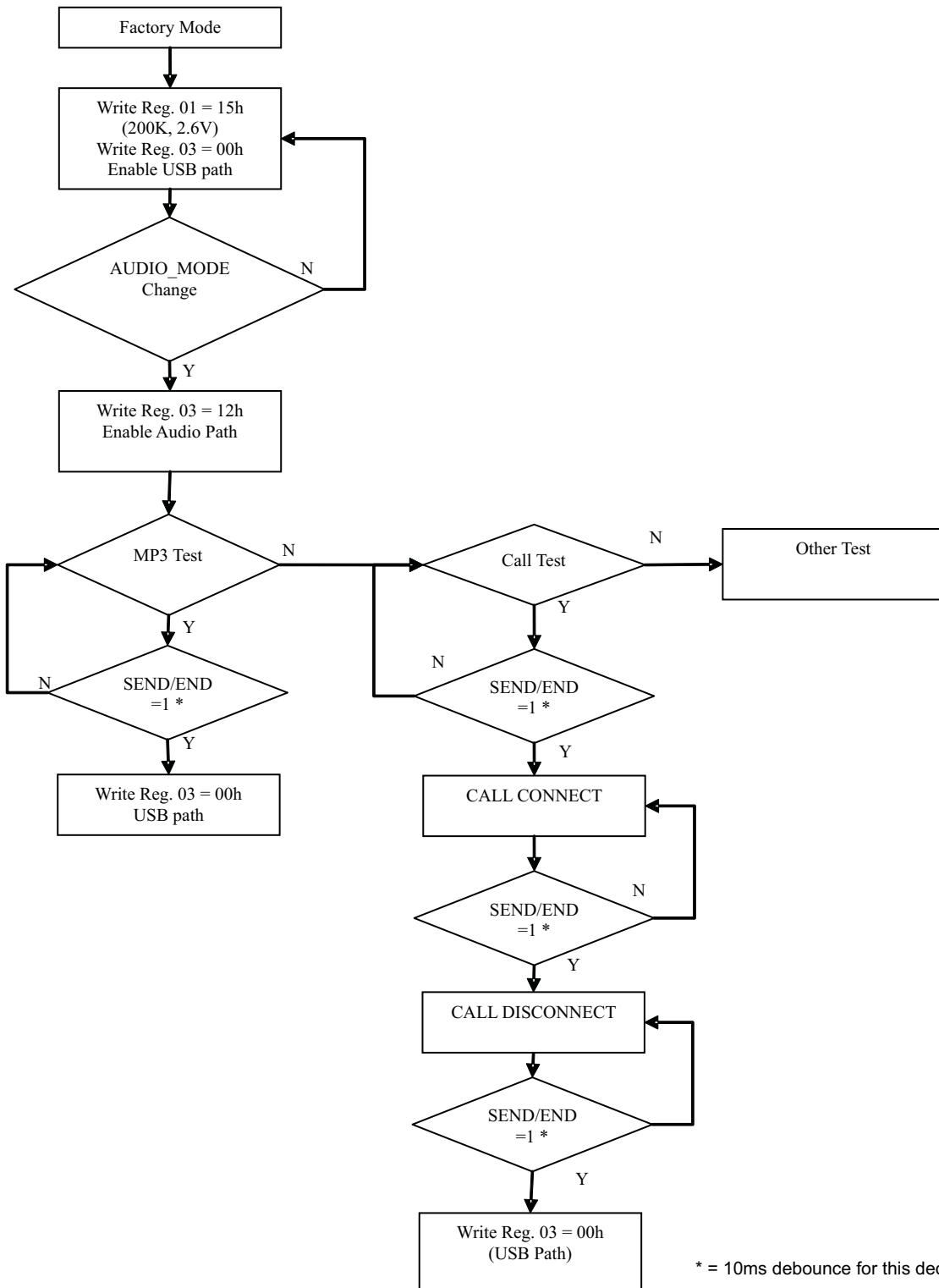

I²C Register Map

ADDRESS (xxh)	NAME	TYPE	RESET VALUE	b7	b6	b5	b4	b3	b2	b1	b0
0	Device ID	R	TBD	VENDOR ID BITS (TI=0001)				REVISION BITS			
1	Control 1	R/W	X0000000	RFU	ID_2P2	ID_620	ID_200	VLDO	SEMREN	ADC_EN	CP_EN
2	Control 2	R/W	0000XX01	INTPOL	INT_EN	MIC_LP	CP_AUD	RFU	RFU	CHG_TYP	USB_DET_DIS
3	SW Control	R/W	See ⁽¹⁾	RFU	MIC_ON	DP[2:0]			DM[2:0]		
4	INT_Status	R	00000000 ⁽¹⁾	CHGDET	MR_COMP	SEND/END	VBUS	IDNO[3: 0]			
5	Status	R	00XXXXXX	DCPORT	CHPORT	RFU	RFU	RFU	RFU	RFU	RFU

(1) Refer INT_Status

Slave Address

NAME	SIZE (BITS)	DESCRIPTION							
		Bit 7	Bit 6	Bit 5	Bit 4	Bit 3	Bit 2	Bit 1	Bit 0
Slave address	8	1	0	0	0	1	0	0	R/W

Register Descriptions

Device ID

Address: 00H

Reset Value: N/A

Type: Read

NAME	SIZE (BITS)	DESCRIPTION
Device ID	8	A unique number for chip version 00000000 bits 0–3 = chip revision, bits 4–7 = Vendor ID (TI = 1xh, Maxim = 2xh)

Control 1

Address: 01H

Reset Value: x0000000

Type: Read/Write

NAME	SIZE (BITS)	DESCRIPTION
ID_2P2	1	0: 2.21 kΩ switch open 1: Connect LDO to ID through 2.21 kΩ external resistor
ID_620	1	0: 620 Ω switch open 1: Connect LDO to ID through 620 Ω internal resistor (used for video)
ID_200	1	0: 200 kΩ switch open 1: Connect LDO to ID through 200 kΩ internal resistor
VLDO	1	0: LDO voltage = 2.6 V (if manual switching mode) 1: LDO voltage = 2.3 V (if manual switching mode)
SEMREN	1	0: Disable send/end and MIC removal comparators and LDO 1: Enable send/end and MIC removal comparators and LDO

NAME	SIZE (BITS)	DESCRIPTION
ADC_EN	1	0: ADC and LDO disabled 1: ADC and LDO enabled
CP_EN	1	0: charge pump disabled 1: charge pump enabled

Control 2

Address: 02H

ADDRESS (xxh)	NAME	TYPE	b7	b6	b5	b4	b3	b2	b1	b0
2	Control 2	R/W	INTPOL	INT_EN	MIC_LP	CP_AUD	RFU	RFU	CHG_TYP	USB_DET_DIS
Reset Value			0	0	0	0	X	X	0	1

NAME	SIZE (BITS)	DESCRIPTION
INT_POL	1	0: Interrupt polarity = active low 1: interrupt polarity = active high
INT_EN	1	0: All interrupts disabled (masked) 1: All interrupts enabled
MIC_LP	1	0: Low power mode - MIC power pulsing disabled 1: Low power mode - MIC power pulsing enabled
CP_AUD	1	0: Click/pop resistors on AUDIO_L and AUDIO_R disabled 1: Click/pop resistors on AUDIO_L and AUDIO_R enabled
CHG_TYP	1	0: Charger type detection disabled 1: Charger type detection enabled
USB_DET_DIS	1	0: USB detection enabled 1: USB detection disabled

SW_Control

Address: 03H

ADDRESS (xxh)	NAME	TYPE	b7	b6	b5	b4	b3	b2	b1	b0
03	SW Control	R/W	RFU	MIC_ON	DP[2:0]			DM[2:0]		
Reset Value			X	0	See ⁽¹⁾			See ⁽¹⁾		

(1) The reset value depends on V_{BUS} status at powerup. If V_{BUS} presents, the default value depends on DSS pin state (refer Default Switch Position session). If V_{BUS} does not present, the default value is 111b (DM/DP switch is open).

NAME	SIZE (BITS)	DESCRIPTION
MIC_ON	1	0: MIC switching path open 1: MIC switching path connected to ID line
DP	3	000: DP connected to USB_DP 001: DP connected to UART_TX 010: DP connected to AUDIO_R 011: Future Use (right Audio for Video)

NAME	SIZE (BITS)	DESCRIPTION
DM	3	000: DM connected to USB_DM 001: DM connected to UART_RX 010: DM connected to AUDIO_L 011: Future Use (left Audio for Video) 100–111: DM switching path open

INT_Status

Address: 04H

ADDRESS (xxh)	NAME	TYPE	b7	b6	b5	b4	b3	b2	b1	b0
04	INT_Status	R	CHGDET	MR_COMP	SEND/END	VBUS	IDNO[3:0]			
Reset Value			0	0	0	0	See ⁽¹⁾			

(1) ADC value of the ID pin

NAME	SIZE (BITS)	DESCRIPTION
CHGDET	1	0: High-current charger not detected 1: High-current charger detected
MR_COMP	1	0: MIC removal comparator low 1: MIC removal comparator high
SEND/END	1	0: ID line not grounded 1: ID line grounded (send/end button pressed)
V _{BUS}	1	0: No power detected on V _{BUS} 1: Power detected on V _{BUS}
IDNO	1	0000: ADC determined ID impedance = 0 Ω (grounded) 0001: ADC determined ID impedance = 24 kΩ 0010: ADC determined ID impedance = 56 kΩ 0011: ADC determined ID impedance = 100 kΩ 0100: ADC determined ID impedance = 130 kΩ 0101: ADC determined ID impedance = 180 kΩ 0110: ADC determined ID impedance = 240 kΩ 0111: ADC determined ID impedance = 330 kΩ 1000: ADC determined ID impedance = 430 kΩ 1001: ADC determined ID impedance = 620 kΩ 1010: ADC determined ID impedance = 910 kΩ 1011: ADC determined ID impedance = open

Status

Address: 05H

ADDRESS (xxh)	NAME	TYPE	b7	b6	b5	b4	b3	b2	b1	b0
5	Status	R	DCPORT	CHPORT	RFU	RFU	RFU	RFU	RFU	RFU
Reset Value			0	0	X	X	X	X	X	X

NAME	SIZE (BITS)	DESCRIPTION
DCPORT	1	0: Dedicated charger not detected 1: Dedicated charger detected
CHPORT	1	0: Charging host port not detected 1: Charging host port detected

Power Consumption

Operating Modes Summary (with estimated power consumption)

	BAND GAP	UVLO	I ² C	DETECTION PLUG	Z DETECTION	CHARGE PUMP	CHARGE PUMP (LOW CURRENT)	TOTAL I _{CC} (μA)
Audio	ON	ON	ON	ON	ON	ON	OFF	59
Audio (no active signal)	ON	ON	ON	ON	ON	OFF	ON	14
UART	ON	ON	ON	ON	ON	OFF	OFF	9
USB	ON	ON	ON	ON	ON	ON	OFF	59
Travel Adapter	ON	ON	ON	ON	OFF	OFF	OFF	8
IDLE	ON	ON	ON	ON	OFF	OFF	OFF	8
Sleep	OFF	OFF	OFF	OFF	OFF	OFF	OFF	0
I _{CC} (μA)	3	2	1	2	1	50	5	

PARAMETER MEASUREMENT INFORMATION

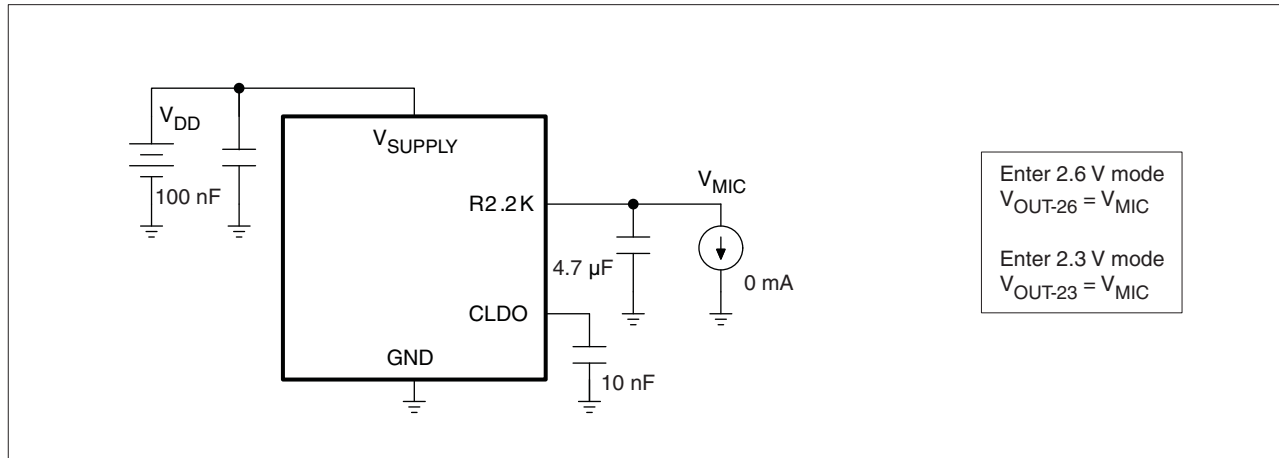

Figure 2. LDO Output Voltage

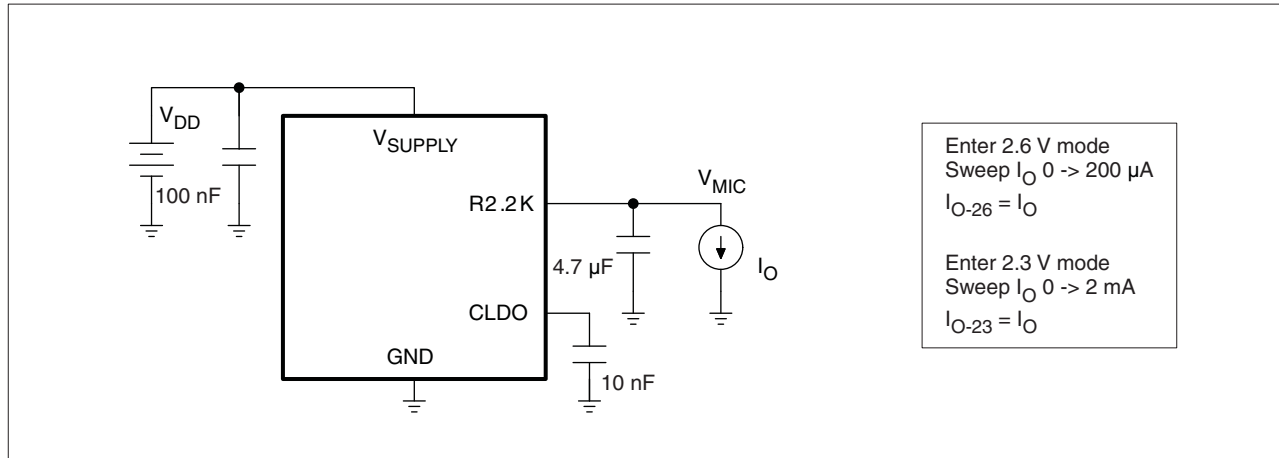

Figure 3. Max Output Current

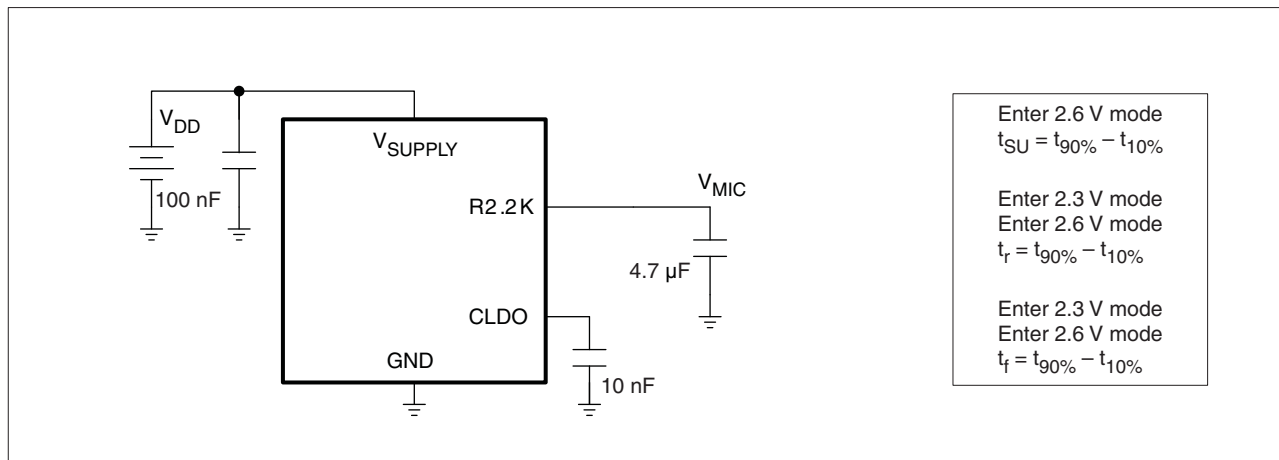

Figure 4. LDO Rise/Fall Time

A. I_O can be set with a resistor.

PARAMETER MEASUREMENT INFORMATION (continued)

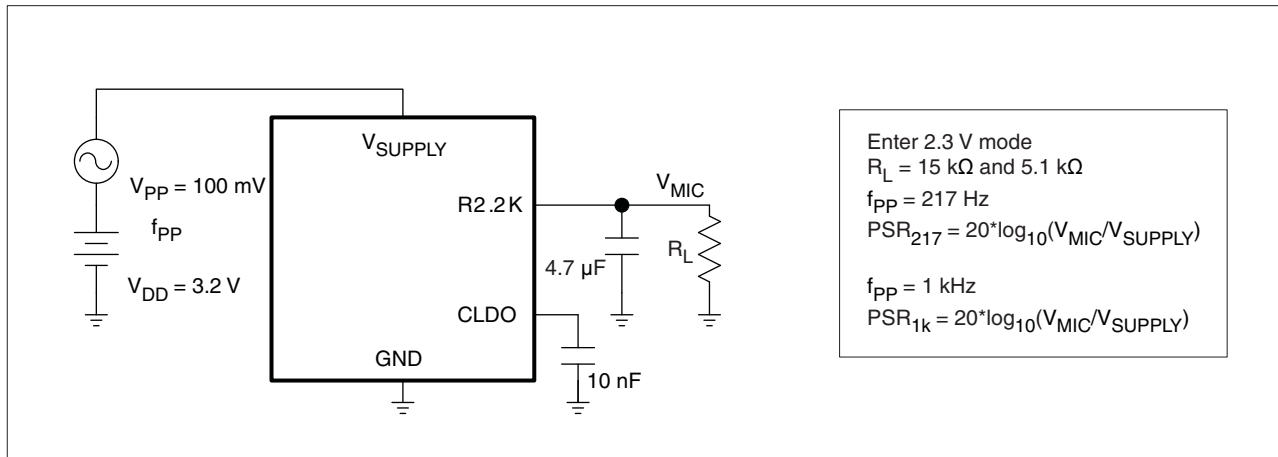

Figure 5. Power Supply Rejection

B. V_{MIC} should be $V_{2.2K}$; add 200 pF on V_{SUPPLY} in LDO output noise.

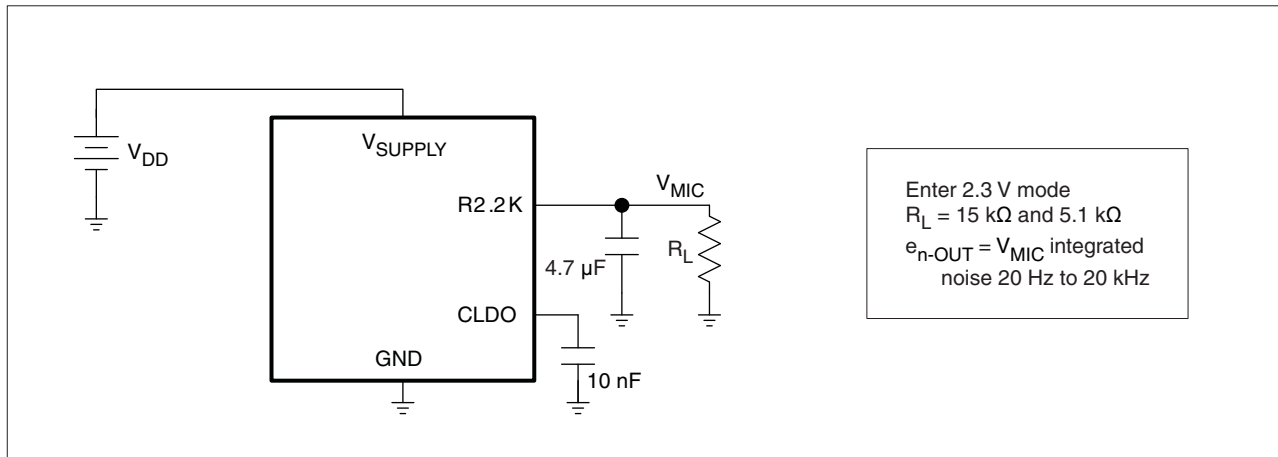

Figure 6. Integrated Output Noise

PACKAGING INFORMATION

Orderable Device	Status ⁽¹⁾	Package Type	Package Drawing	Pins	Package Qty	Eco Plan ⁽²⁾	Lead/ Ball Finish	MSL Peak Temp ⁽³⁾	Samples (Requires Login)
TS5USBA43402YZPR	ACTIVE	DSBGA	YZP	20	3000	Green (RoHS & no Sb/Br)	Call TI	Level-1-260C-UNLIM	Request Free Samples

⁽¹⁾ The marketing status values are defined as follows:

ACTIVE: Product device recommended for new designs.

LIFEBUY: TI has announced that the device will be discontinued, and a lifetime-buy period is in effect.

NRND: Not recommended for new designs. Device is in production to support existing customers, but TI does not recommend using this part in a new design.

PREVIEW: Device has been announced but is not in production. Samples may or may not be available.

OBSOLETE: TI has discontinued the production of the device.

⁽²⁾ Eco Plan - The planned eco-friendly classification: Pb-Free (RoHS), Pb-Free (RoHS Exempt), or Green (RoHS & no Sb/Br) - please check <http://www.ti.com/productcontent> for the latest availability information and additional product content details.

TBD: The Pb-Free/Green conversion plan has not been defined.

Pb-Free (RoHS): TI's terms "Lead-Free" or "Pb-Free" mean semiconductor products that are compatible with the current RoHS requirements for all 6 substances, including the requirement that lead not exceed 0.1% by weight in homogeneous materials. Where designed to be soldered at high temperatures, TI Pb-Free products are suitable for use in specified lead-free processes.

Pb-Free (RoHS Exempt): This component has a RoHS exemption for either 1) lead-based flip-chip solder bumps used between the die and package, or 2) lead-based die adhesive used between the die and leadframe. The component is otherwise considered Pb-Free (RoHS compatible) as defined above.

Green (RoHS & no Sb/Br): TI defines "Green" to mean Pb-Free (RoHS compatible), and free of Bromine (Br) and Antimony (Sb) based flame retardants (Br or Sb do not exceed 0.1% by weight in homogeneous material)

⁽³⁾ MSL, Peak Temp. -- The Moisture Sensitivity Level rating according to the JEDEC industry standard classifications, and peak solder temperature.

Important Information and Disclaimer: The information provided on this page represents TI's knowledge and belief as of the date that it is provided. TI bases its knowledge and belief on information provided by third parties, and makes no representation or warranty as to the accuracy of such information. Efforts are underway to better integrate information from third parties. TI has taken and continues to take reasonable steps to provide representative and accurate information but may not have conducted destructive testing or chemical analysis on incoming materials and chemicals. TI and TI suppliers consider certain information to be proprietary, and thus CAS numbers and other limited information may not be available for release.

In no event shall TI's liability arising out of such information exceed the total purchase price of the TI part(s) at issue in this document sold by TI to Customer on an annual basis.

TAPE AND REEL INFORMATION

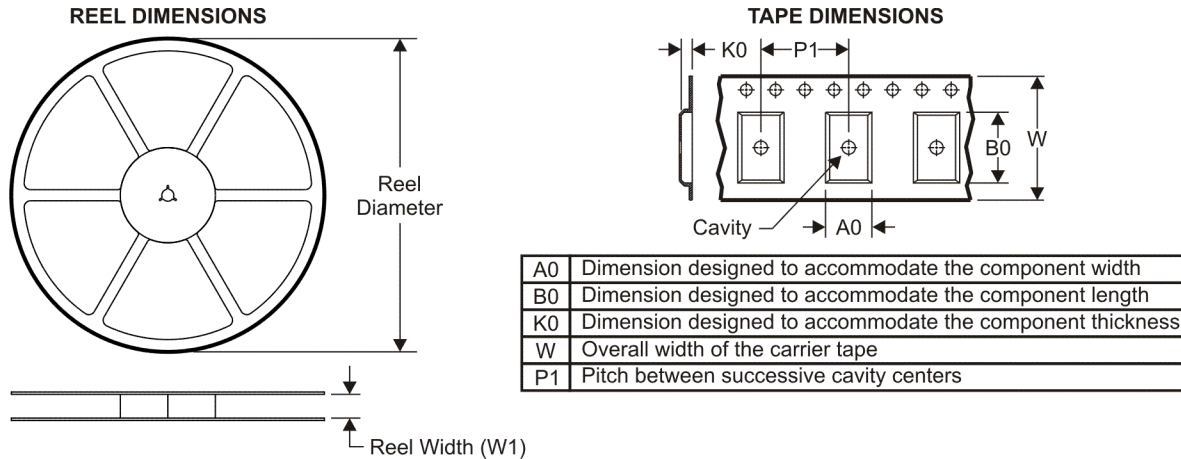

QUADRANT ASSIGNMENTS FOR PIN 1 ORIENTATION IN TAPE

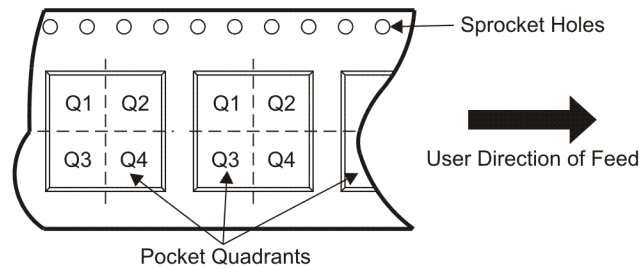

*All dimensions are nominal

Device	Package Type	Package Drawing	Pins	SPQ	Reel Diameter (mm)	Reel Width W1 (mm)	A0 (mm)	B0 (mm)	K0 (mm)	P1 (mm)	W (mm)	Pin1 Quadrant
TS5USBA43402YZPR	DSBGA	YZP	20	3000	180.0	8.4	2.02	2.52	0.63	4.0	8.0	Q1

TAPE AND REEL BOX DIMENSIONS



*All dimensions are nominal

Device	Package Type	Package Drawing	Pins	SPQ	Length (mm)	Width (mm)	Height (mm)
TS5USBA43402YZPR	DSBGA	YZP	20	3000	220.0	220.0	34.0

IMPORTANT NOTICE

Texas Instruments Incorporated and its subsidiaries (TI) reserve the right to make corrections, modifications, enhancements, improvements, and other changes to its products and services at any time and to discontinue any product or service without notice. Customers should obtain the latest relevant information before placing orders and should verify that such information is current and complete. All products are sold subject to TI's terms and conditions of sale supplied at the time of order acknowledgment.

TI warrants performance of its hardware products to the specifications applicable at the time of sale in accordance with TI's standard warranty. Testing and other quality control techniques are used to the extent TI deems necessary to support this warranty. Except where mandated by government requirements, testing of all parameters of each product is not necessarily performed.

TI assumes no liability for applications assistance or customer product design. Customers are responsible for their products and applications using TI components. To minimize the risks associated with customer products and applications, customers should provide adequate design and operating safeguards.

TI does not warrant or represent that any license, either express or implied, is granted under any TI patent right, copyright, mask work right, or other TI intellectual property right relating to any combination, machine, or process in which TI products or services are used. Information published by TI regarding third-party products or services does not constitute a license from TI to use such products or services or a warranty or endorsement thereof. Use of such information may require a license from a third party under the patents or other intellectual property of the third party, or a license from TI under the patents or other intellectual property of TI.

Reproduction of TI information in TI data books or data sheets is permissible only if reproduction is without alteration and is accompanied by all associated warranties, conditions, limitations, and notices. Reproduction of this information with alteration is an unfair and deceptive business practice. TI is not responsible or liable for such altered documentation. Information of third parties may be subject to additional restrictions.

Resale of TI products or services with statements different from or beyond the parameters stated by TI for that product or service voids all express and any implied warranties for the associated TI product or service and is an unfair and deceptive business practice. TI is not responsible or liable for any such statements.

TI products are not authorized for use in safety-critical applications (such as life support) where a failure of the TI product would reasonably be expected to cause severe personal injury or death, unless officers of the parties have executed an agreement specifically governing such use. Buyers represent that they have all necessary expertise in the safety and regulatory ramifications of their applications, and acknowledge and agree that they are solely responsible for all legal, regulatory and safety-related requirements concerning their products and any use of TI products in such safety-critical applications, notwithstanding any applications-related information or support that may be provided by TI. Further, Buyers must fully indemnify TI and its representatives against any damages arising out of the use of TI products in such safety-critical applications.

TI products are neither designed nor intended for use in military/aerospace applications or environments unless the TI products are specifically designated by TI as military-grade or "enhanced plastic." Only products designated by TI as military-grade meet military specifications. Buyers acknowledge and agree that any such use of TI products which TI has not designated as military-grade is solely at the Buyer's risk, and that they are solely responsible for compliance with all legal and regulatory requirements in connection with such use.

TI products are neither designed nor intended for use in automotive applications or environments unless the specific TI products are designated by TI as compliant with ISO/TS 16949 requirements. Buyers acknowledge and agree that, if they use any non-designated products in automotive applications, TI will not be responsible for any failure to meet such requirements.

Following are URLs where you can obtain information on other Texas Instruments products and application solutions:

Products		Applications	
Amplifiers	amplifier.ti.com	Audio	www.ti.com/audio
Data Converters	dataconverter.ti.com	Automotive	www.ti.com/automotive
DLP® Products	www.dlp.com	Communications and Telecom	www.ti.com/communications
DSP	dsp.ti.com	Computers and Peripherals	www.ti.com/computers
Clocks and Timers	www.ti.com/clocks	Consumer Electronics	www.ti.com/consumer-apps
Interface	interface.ti.com	Energy	www.ti.com/energy
Logic	logic.ti.com	Industrial	www.ti.com/industrial
Power Mgmt	power.ti.com	Medical	www.ti.com/medical
Microcontrollers	microcontroller.ti.com	Security	www.ti.com/security
RFID	www.ti-rfid.com	Space, Avionics & Defense	www.ti.com/space-avionics-defense
RF/IF and ZigBee® Solutions	www.ti.com/lprf	Video and Imaging	www.ti.com/video
		Wireless	www.ti.com/wireless-apps

Mailing Address: Texas Instruments, Post Office Box 655303, Dallas, Texas 75265
Copyright © 2010, Texas Instruments Incorporated

Looking for pricing, stock, or lifecycle information?

Click below to explore more details on WIN SOURCE:

 [View TS5USBA43402YZPR on WIN SOURCE](#)

 [Texas Instruments](#) Information

Optimize Your Supply Chain with WIN SOURCE Solutions

-  Global Sourcing Solution
-  Obsolete Management
-  Cost Control Management
-  Shortage Management
-  Alternative Solution
-  Excess Inventory Management