



**THE DATASHEET OF
TLC7733QPWRQ1**



TLC7701-Q1, TLC7705-Q1, TLC7733-Q1 MICROPOWER SUPPLY VOLTAGE SUPERVISORS

SGLS208A – OCTOBER 2003 – REVISED MAY 2008

- Qualified for Automotive Applications
- Power-On Reset Generator
- Automatic Reset Generation After Voltage Drop
- Precision Voltage Sensor
- Temperature-Compensated Voltage Reference
- Programmable Delay Time by External Capacitor
- Supply Voltage Range . . . 2 V to 6 V
- Defined $\overline{\text{RESET}}$ Output from $V_{\text{DD}} \geq 1 \text{ V}$
- Power-Down Control Support for Static RAM With Battery Backup
- Maximum Supply Current of 16 μA
- Power Saving Totem-Pole Outputs

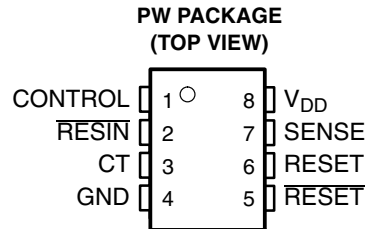

description

The TLC77xx family of micropower supply voltage supervisors provide reset control, primarily in microcomputer and microprocessor systems.

During power-on, $\overline{\text{RESET}}$ is asserted when V_{DD} reaches 1 V. After minimum $V_{\text{DD}} (\geq 2 \text{ V})$ is established, the circuit monitors SENSE voltage and keeps the reset outputs active as long as SENSE voltage ($V_{\text{I}(\text{SENSE})}$) remains below the threshold voltage. An internal timer delays return of the output to the inactive state to ensure proper system reset. The delay time, t_{d} , is determined by an external capacitor:

$$t_{\text{d}} = 2.1 \times 10^4 \times C_{\text{T}}$$

Where

C_{T} is in farads

t_{d} is in seconds

Except for the TLC7701, which can be customized with two external resistors, each supervisor has a fixed SENSE threshold voltage set by an internal voltage divider. When SENSE voltage drops below the threshold voltage, the outputs become active and stay in that state until SENSE voltage returns above threshold voltage and the delay time, t_{d} , has expired.

In addition to the power-on-reset and undervoltage-supervisor function, the TLC77xx adds power-down control support for static RAM. When CONTROL is tied to GND, RESET will act as active high. The voltage monitor contains additional logic intended for control of static memories with battery backup during power failure. By driving the chip select ($\overline{\text{CS}}$) of the memory circuit with the RESET output of the TLC77xx and with the CONTROL driven by the memory bank select signal ($\overline{\text{CSH1}}$) of the microprocessor (see Figure 10), the memory circuit is automatically disabled during a power loss. (In this application the TLC77xx power has to be supplied by the battery.)



Please be aware that an important notice concerning availability, standard warranty, and use in critical applications of Texas Instruments semiconductor products and disclaimers thereto appears at the end of this data sheet.

PRODUCTION DATA information is current as of publication date. Products conform to specifications per the terms of Texas Instruments standard warranty. Production processing does not necessarily include testing of all parameters.

 **TEXAS
INSTRUMENTS**

POST OFFICE BOX 655303 • DALLAS, TEXAS 75265

Copyright © 2008, Texas Instruments Incorporated

TLC7701-Q1, TLC7705-Q1, TLC7733-Q1 MICROPOWER SUPPLY VOLTAGE SUPERVISORS

SGLS208A – OCTOBER 2003 – REVISED MAY 2008

ORDERING INFORMATION†‡

T _A	PACKAGE§		ORDERABLE PART NUMBER	TOP-SIDE MARKING
-40°C to 125°C	TSSOP – PW	Tape and reel	TLC7701QPWRQ1	7701Q1
	TSSOP – PW	Tape and reel	TLC7705QPWRQ1	7705Q1
	TSSOP – PW	Tape and reel	TLC7733QPWRQ1	7733Q1

† For the most current package and ordering information, see the Package Option Addendum at the end of this document, or see the TI web site at <http://www.ti.com>.

‡ Package drawings, thermal data, and symbolization are available at <http://www.ti.com/packaging>.

§ The PW package is only available left-end taped and reeled (indicated by the R suffix on the device type; e.g., TLC7701QPWREP).

FUNCTION TABLE

CONTROL	RESIN	V _{I(SENSE)} > V _{IT+}	RESET	RESET
L	L	False	H	L
L	L	True	H	L
L	H	False	H	L
L	H	True	L§	H§
H	L	False	H	L
H	L	True	H	L
H	H	False	H	L
H	H	True	H	H§

§ RESET and RESET states shown are valid for $t > t_d$.

logic symbol¶

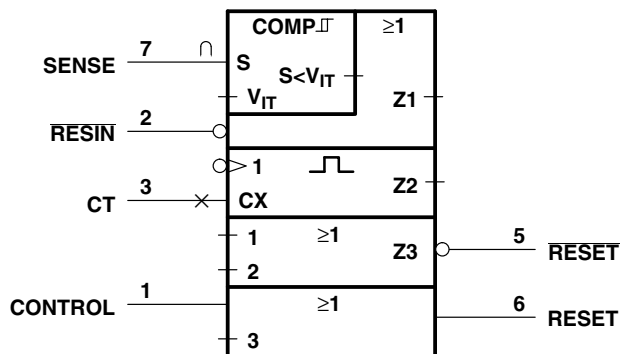

¶ This symbol is in accordance with ANSI/IEEE Std 91-1984 and IEC Publication 617-12.

TLC7701-Q1, TLC7705-Q1, TLC7733-Q1 MICROPOWER SUPPLY VOLTAGE SUPERVISORS

SGLS208A – OCTOBER 2003 – REVISED MAY 2008

functional block diagram

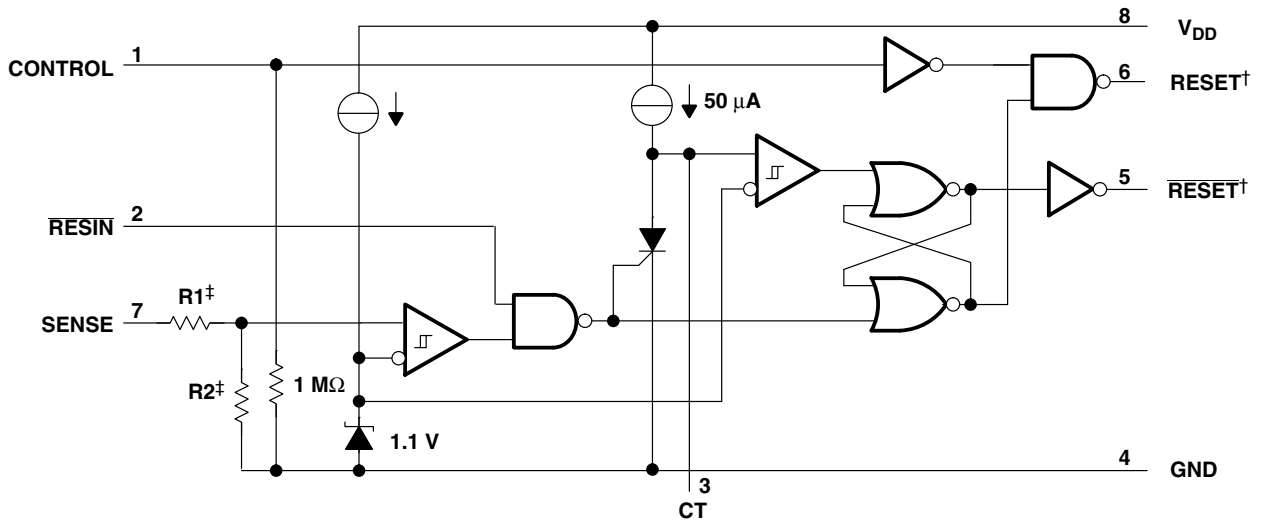

† Outputs are totem-pole configuration. External pullup or pulldown resistors are not required.

‡ Nominal values:

	R1 (Typ)	R2 (Typ)
TLC7701	0	∞
TLC7705	910 kΩ	290 kΩ
TLC7733	750 kΩ	450 kΩ

TLC7701-Q1, TLC7705-Q1, TLC7733-Q1 MICROPOWER SUPPLY VOLTAGE SUPERVISORS

SGLS208A – OCTOBER 2003 – REVISED MAY 2008

timing diagram

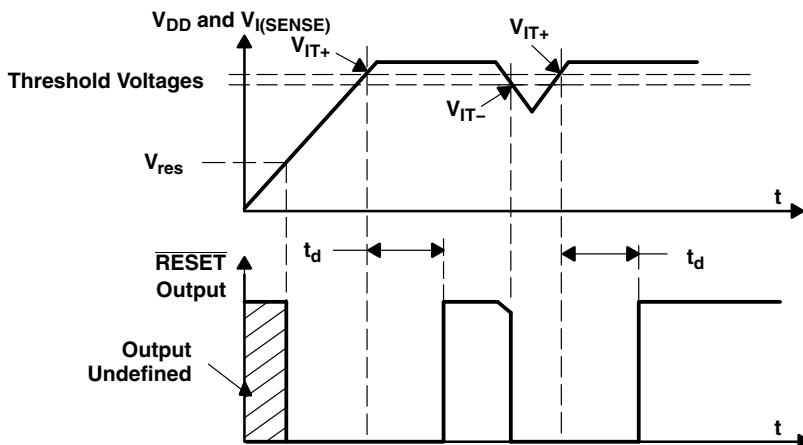

absolute maximum ratings over operating free-air temperature (unless otherwise noted)†

Supply voltage, V_{DD} (see Note 1)	7 V
Input voltage range, CONTROL, $\overline{\text{RESIN}}$, SENSE (see Note 1)	-0.3 V to 7 V
Maximum low output current, I_{OL}	10 mA
Maximum high output current, I_{OH}	-10 mA
Input clamp current, I_{IK} ($V_I < 0$ or $V_I > V_{DD}$)	± 10 mA
Output clamp current, I_{OK} ($V_O < 0$ or $V_O > V_{DD}$)	± 10 mA
Continuous total power dissipation	See Dissipation Rating Table
Operating free-air temperature range, T_A : TL77xxQ	-40°C to 125°C
Storage temperature range, T_{stg}	-65°C to 150°C

† Stresses beyond those listed under “absolute maximum ratings” may cause permanent damage to the device. These are stress ratings only, and functional operation of the device at these or any other conditions beyond those indicated under “recommended operating conditions” is not implied. Exposure to absolute-maximum-rated conditions for extended periods may affect device reliability.

NOTE 1: All voltage values are with respect to GND.

DISSIPATION RATING TABLE

PACKAGE	$T_A \leq 25^\circ\text{C}$ POWER RATING	DERATING FACTOR ABOVE $T_A = 25^\circ\text{C}$	$T_A = 85^\circ\text{C}$ POWER RATING	$T_A = 125^\circ\text{C}$ POWER RATING
PW	525 mW	4.2 mW/°C	273 mW	105 mW

recommended operating conditions at specified temperature range

	MIN	MAX	UNIT
Supply voltage, V_{DD}	2	6	V
Input voltage, V_I	0	V_{DD}	V
High-level input voltage at $\overline{\text{RESIN}}$ and CONTROL‡, V_{IH}	$0.7 \times V_{DD}$		V
Low-level input voltage at $\overline{\text{RESIN}}$ and CONTROL‡, V_{IL}		$0.2 \times V_{DD}$	V
High-level output current, I_{OH}		-2	mA
Low-level output current, I_{OL}	$V_{DD} \geq 2.7$ V	2	mA
Input transition rise and fall rate at $\overline{\text{RESIN}}$ and CONTROL, $\Delta t/\Delta V$		100	ns/V
Operating free-air temperature range, T_A	-40	125	°C

‡ To ensure a low supply current, V_{IL} should be kept < 0.3 V and $V_{IH} > V_{DD} - 0.3$ V.



POST OFFICE BOX 655303 • DALLAS, TEXAS 75265

TLC7701-Q1, TLC7705-Q1, TLC7733-Q1 MICROPOWER SUPPLY VOLTAGE SUPERVISORS

SGLS208A – OCTOBER 2003 – REVISED MAY 2008

electrical characteristics over recommended operating conditions (see Note 2) (unless otherwise noted)

PARAMETER		TEST CONDITIONS	TLC77xx			UNIT	
			MIN	TYP†	MAX		
V _{OH}	High-level output voltage	I _{OH} = -20 µA	V _{DD} = 2 V	1.8		V	
			V _{DD} = 2.7 V	2.5			
			V _{DD} = 4.5 V	4.3			
		I _{OH} = -2 mA	V _{DD} = 4.5 V	3.7			
V _{OL}	Low-level output voltage	I _{OL} = 20 µA	V _{DD} = 2 V	0.2		V	
			V _{DD} = 2.7 V	0.2			
			V _{DD} = 4.5 V	0.2			
		I _{OL} = 2 mA	V _{DD} = 4.5 V	0.5			
V _{IT-}	Negative-going input threshold voltage, SENSE (see Note 3)	TLC7701	V _{DD} = 2 V to 6 V	1.04	1.1	1.16	V
		TLC7705		4.43	4.5	4.63	
		TLC7733		2.855	2.93	3.03	
V _{hys}	Hysteresis voltage, SENSE	TLC7701	V _{DD} = 2 V to 6 V	30		mV	
		TLC7705		70			
		TLC7733					
V _{res}	Power-up reset voltage‡	I _{OL} = 20 µA			1	V	
I _I	Input current	RESIN	V _I = 0 V to V _{DD}			2	µA
		CONTROL	V _I = V _{DD}		7	15	
		SENSE	V _I = 5 V		5	10	
		SENSE, TLC7701 only	V _I = 5 V			2	
I _{DD}	Supply current	RESIN = V _{DD} , SENSE = V _{DD} ≥ V _{ITmax} + 0.2 V CONTROL = 0 V, Outputs open		9	16	µA	
I _{DD(d)}	Supply current during t _d	V _{DD} = 5 V, V _{CT} = 0, RESIN = V _{DD} , SENSE = V _{DD} , CONTROL = 0 V, Outputs open		120	150	µA	
C _I	Input capacitance, SENSE	V _I = 0 V to V _{DD}		50		pF	

† Typical values apply at T_A = 25°C.

‡ The lowest supply voltage at which RESET becomes active. The symbol V_{res} is not currently listed within EIA or JEDEC standards for semiconductor symbology. Rise time of V_{DD} ≥ 15 µs/V.

NOTES: 2. All characteristics are measured with C_T = 0.1 µF.

3. To ensure best stability of the threshold voltage, a bypass capacitor (ceramic, 0.1 µF) should be connected near the supply terminals.



TLC7701-Q1, TLC7705-Q1, TLC7733-Q1 MICROPOWER SUPPLY VOLTAGE SUPERVISORS

SGLS208A – OCTOBER 2003 – REVISED MAY 2008

switching characteristics at $V_{DD} = 5\text{ V}$, $R_L = 2\text{ k}\Omega$, $C_L = 50\text{ pF}$, $T_A = \text{Full Range}$ (unless otherwise noted)

PARAMETER	MEASURED		TEST CONDITIONS	TLC77xx			UNIT
	FROM (INPUT)	TO (OUTPUT)		MIN	TYP	MAX	
t_d Delay time	$V_{I(\text{SENSE})} \geq V_{IT+}$	RESET and RESET	$\overline{\text{RESIN}} = 0.7 \times V_{DD}$, CONTROL = $0.2 \times V_{DD}$, $C_T = 100\text{ nF}$, $T_A = \text{Full range}$, See timing diagram	1.1	2.1	4.2	ms
t_{PLH} Propagation delay time, low-to-high-level output	SENSE	RESET	$V_{IH} = V_{IT+max} + 0.2\text{ V}$, $V_{IL} = V_{IT+min} - 0.2\text{ V}$, $\overline{\text{RESIN}} = 0.7 \times V_{DD}$, CONTROL = $0.2 \times V_{DD}$, CT = NC†	20			μs
t_{PHL} Propagation delay time, high-to-low-level output		RESET		5			
t_{PLH} Propagation delay time, low-to-high-level output		RESET		5			
t_{PHL} Propagation delay time, high-to-low-level output		RESET		20			
t_{PLH} Propagation delay time, low-to-high-level output	$\overline{\text{RESIN}}$	RESET	$V_{IH} = 0.7 \times V_{DD}$, $V_{IL} = 0.2 \times V_{DD}$, SENSE = $V_{IT+max} + 0.2\text{ V}$, CONTROL = $0.2 \times V_{DD}$, CT = NC†	20			μs
t_{PHL} Propagation delay time, high-to-low-level output		RESET		60			
t_{PLH} Propagation delay time, low-to-high-level output		RESET		65			ns
t_{PHL} Propagation delay time, high-to-low-level output		RESET		20			
t_{PLH} Propagation delay time, low-to-high-level output	CONTROL	RESET	$V_{IH} = 0.7 \times V_{DD}$, $V_{IL} = 0.2 \times V_{DD}$, SENSE = $V_{IT+max} + 0.2\text{ V}$, $\overline{\text{RESIN}} = 0.7 \times V_{DD}$, CT = NC†	58			ns
t_{PHL} Propagation delay time, high-to-low-level output		RESET		58			
Low-level minimum pulse duration to switch RESET and RESET	SENSE		$V_{IH} = V_{IT+max} + 0.2\text{ V}$, $V_{IL} = V_{IT+min} - 0.2\text{ V}$, $V_{IL} = 0.2 \times V_{DD}$, $V_{IH} = 0.7 \times V_{DD}$	3			μs
	$\overline{\text{RESIN}}$			1			
t_r Rise time		RESET and RESET	10% to 90%	8			ns/V
t_f Fall time		RESET and RESET	90% to 10%	4			

† NC = No capacitor, and includes up to 100-pF probe and jig capacitance.



PARAMETER MEASUREMENT INFORMATION

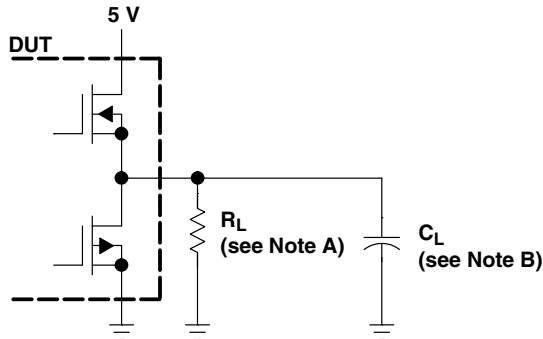

NOTES: A. For switching characteristics, $R_L = 2\text{ k}\Omega$.
B. $C_L = 50\text{ pF}$ includes jig and probe capacitance.

Figure 1. RESET AND $\overline{\text{RESET}}$ Output Configurations

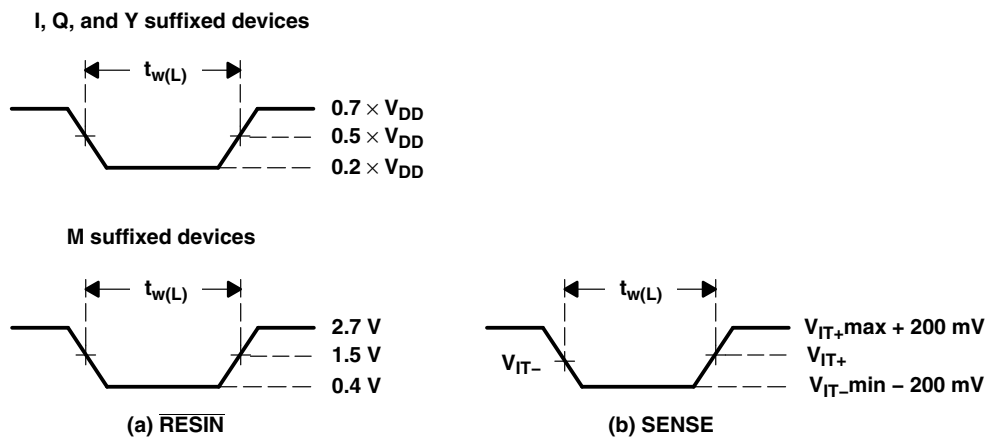

Figure 2. Input Pulse Definition Waveforms

TLC7701-Q1, TLC7705-Q1, TLC7733-Q1 MICROPOWER SUPPLY VOLTAGE SUPERVISORS

SGLS208A – OCTOBER 2003 – REVISED MAY 2008

TYPICAL CHARACTERISTICS

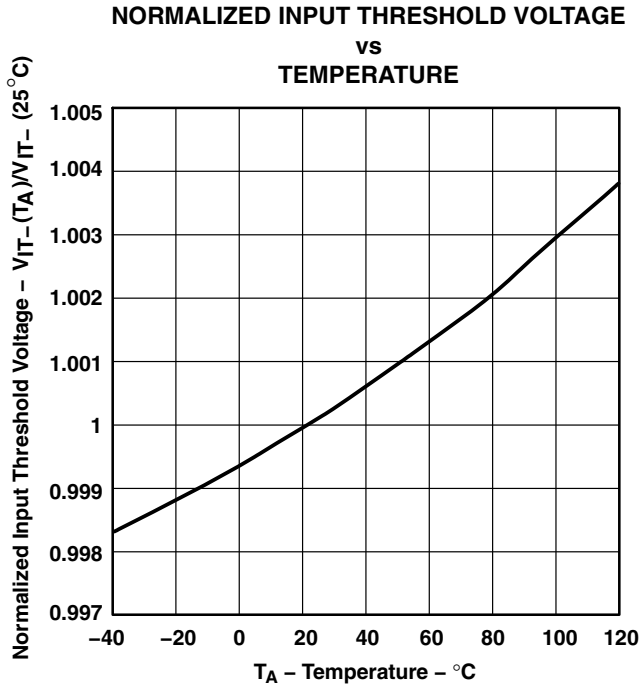

Figure 3

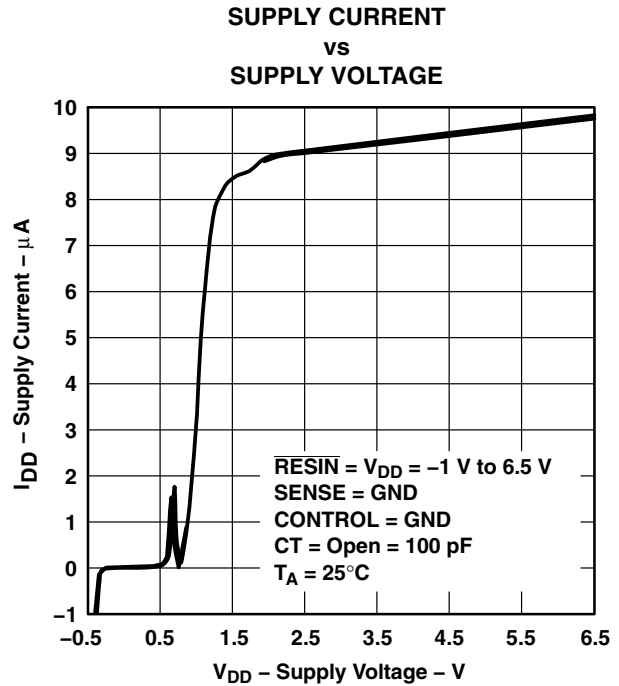

Figure 4

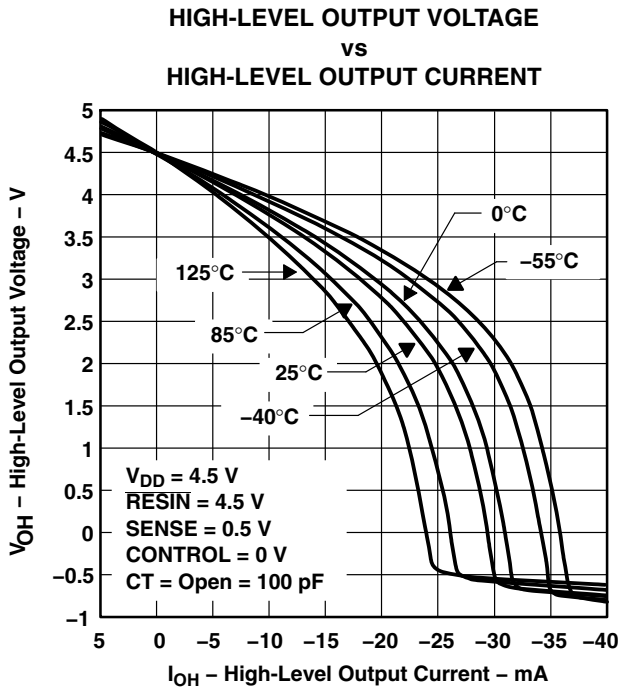

Figure 5

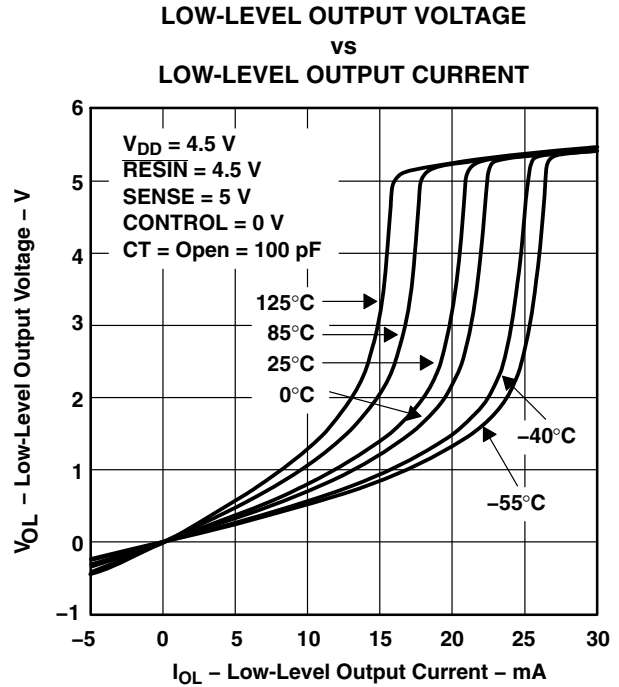
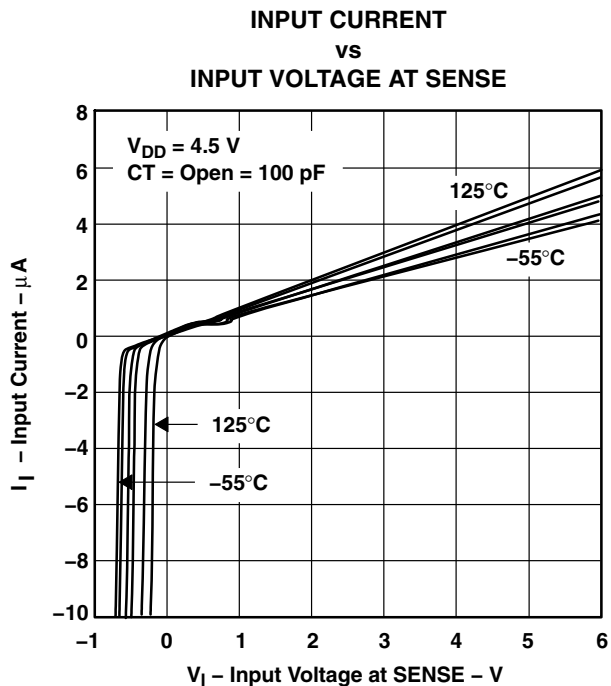

Figure 6



TYPICAL CHARACTERISTICS



**MINIMUM PULSE DURATION AT SENSE
vs
SENSE THRESHOLD OVERDRIVE**

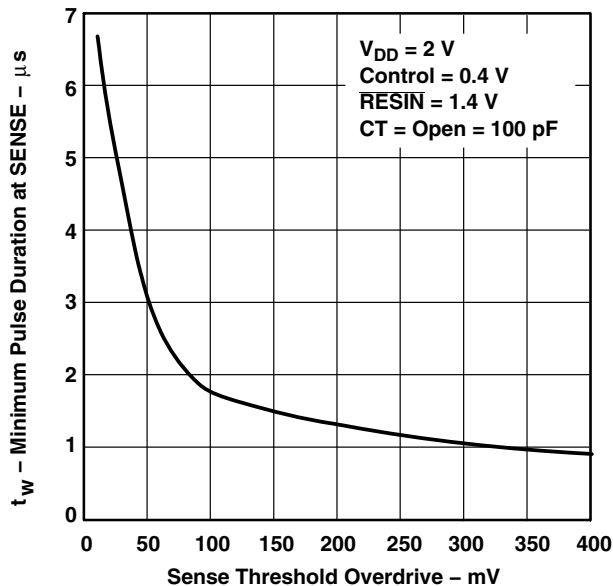

TLC7701-Q1, TLC7705-Q1, TLC7733-Q1 MICROPOWER SUPPLY VOLTAGE SUPERVISORS

SGLS208A – OCTOBER 2003 – REVISED MAY 2008

APPLICATION INFORMATION

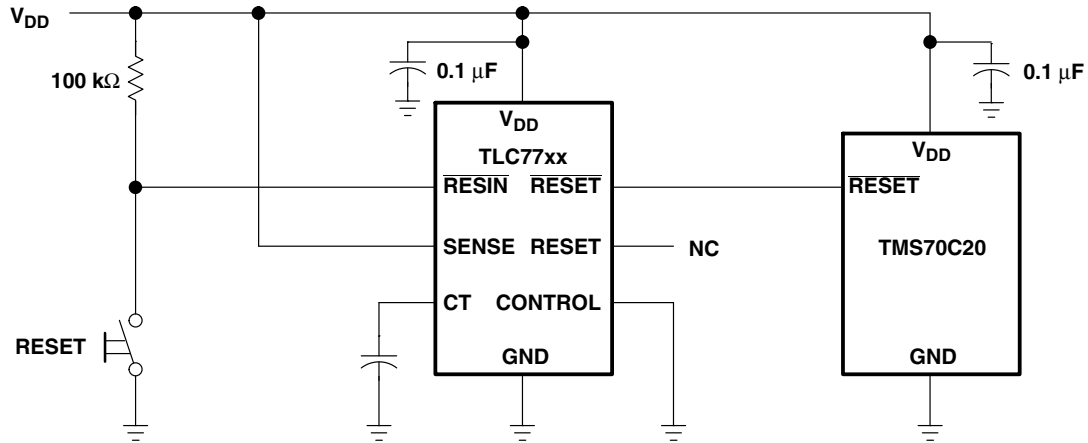

Figure 9. Reset Controller in a Microcomputer System

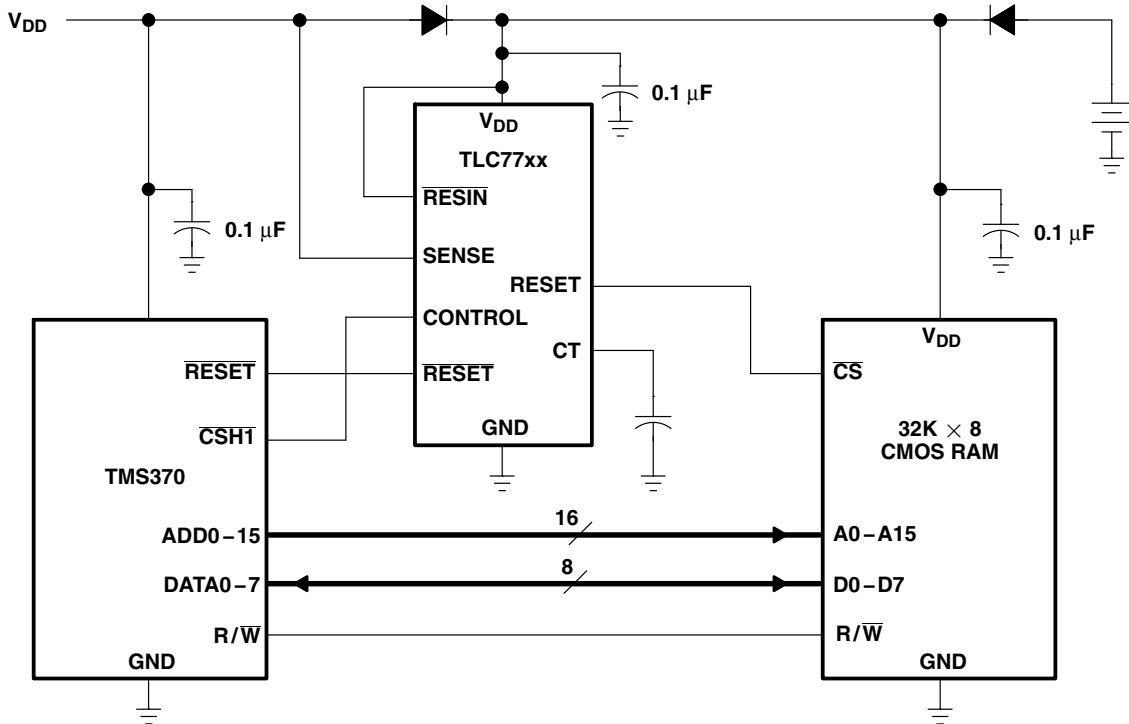

Figure 10. Data Retention During Power Down Using Static CMOS RAMs

PACKAGING INFORMATION

Orderable Device	Status (1)	Package Type	Package Drawing	Pins	Package Qty	Eco Plan (2)	Lead/Ball Finish (6)	MSL Peak Temp (3)	Op Temp (°C)	Device Marking (4/5)	Samples
TLC7701QPWRG4Q1	ACTIVE	TSSOP	PW	8	2000	Green (RoHS & no Sb/Br)	CU NIPDAU	Level-1-260C-UNLIM	-40 to 125	7701Q1	Samples
TLC7701QPWRQ1	ACTIVE	TSSOP	PW	8	2500	Green (RoHS & no Sb/Br)	CU NIPDAU	Level-1-260C-UNLIM	-40 to 125	7701Q1	Samples
TLC7705QPWRG4Q1	ACTIVE	TSSOP	PW	8	2000	Green (RoHS & no Sb/Br)	CU NIPDAU	Level-1-260C-UNLIM	-40 to 125	7705Q1	Samples
TLC7733QPWRG4Q1	ACTIVE	TSSOP	PW	8	2000	Green (RoHS & no Sb/Br)	CU NIPDAU	Level-1-260C-UNLIM	-40 to 125	7733Q1	Samples
TLC7733QPWRQ1	ACTIVE	TSSOP	PW	8	2000	Green (RoHS & no Sb/Br)	CU NIPDAU	Level-1-260C-UNLIM	-40 to 125	7733Q1	Samples

(1) The marketing status values are defined as follows:

ACTIVE: Product device recommended for new designs.

LIFEBUY: TI has announced that the device will be discontinued, and a lifetime-buy period is in effect.

NRND: Not recommended for new designs. Device is in production to support existing customers, but TI does not recommend using this part in a new design.

PREVIEW: Device has been announced but is not in production. Samples may or may not be available.

OBsolete: TI has discontinued the production of the device.

(2) **RoHS:** TI defines "RoHS" to mean semiconductor products that are compliant with the current EU RoHS requirements for all 10 RoHS substances, including the requirement that RoHS substance do not exceed 0.1% by weight in homogeneous materials. Where designed to be soldered at high temperatures, "RoHS" products are suitable for use in specified lead-free processes. TI may reference these types of products as "Pb-Free".

RoHS Exempt: TI defines "RoHS Exempt" to mean products that contain lead but are compliant with EU RoHS pursuant to a specific EU RoHS exemption.

Green: TI defines "Green" to mean the content of Chlorine (Cl) and Bromine (Br) based flame retardants meet JS709B low halogen requirements of <=1000ppm threshold. Antimony trioxide based flame retardants must also meet the <=1000ppm threshold requirement.

(3) MSL, Peak Temp. - The Moisture Sensitivity Level rating according to the JEDEC industry standard classifications, and peak solder temperature.

(4) There may be additional marking, which relates to the logo, the lot trace code information, or the environmental category on the device.

(5) Multiple Device Markings will be inside parentheses. Only one Device Marking contained in parentheses and separated by a "-" will appear on a device. If a line is indented then it is a continuation of the previous line and the two combined represent the entire Device Marking for that device.

(6) Lead/Ball Finish - Orderable Devices may have multiple material finish options. Finish options are separated by a vertical ruled line. Lead/Ball Finish values may wrap to two lines if the finish value exceeds the maximum column width.

Important Information and Disclaimer:The information provided on this page represents TI's knowledge and belief as of the date that it is provided. TI bases its knowledge and belief on information provided by third parties, and makes no representation or warranty as to the accuracy of such information. Efforts are underway to better integrate information from third parties. TI has taken and continues to take reasonable steps to provide representative and accurate information but may not have conducted destructive testing or chemical analysis on incoming materials and chemicals. TI and TI suppliers consider certain information to be proprietary, and thus CAS numbers and other limited information may not be available for release.

In no event shall TI's liability arising out of such information exceed the total purchase price of the TI part(s) at issue in this document sold by TI to Customer on an annual basis.

OTHER QUALIFIED VERSIONS OF TLC77-Q1 :

- Catalog: [TLC77](#)
- Enhanced Product: [TLC77-EP](#)

NOTE: Qualified Version Definitions:

- Catalog - TI's standard catalog product
- Enhanced Product - Supports Defense, Aerospace and Medical Applications

TAPE AND REEL INFORMATION

QUADRANT ASSIGNMENTS FOR PIN 1 ORIENTATION IN TAPE

*All dimensions are nominal

Device	Package Type	Package Drawing	Pins	SPQ	Reel Diameter (mm)	Reel Width W1 (mm)	A0 (mm)	B0 (mm)	K0 (mm)	P1 (mm)	W (mm)	Pin1 Quadrant
TLC7701QPWRG4Q1	TSSOP	PW	8	2000	330.0	12.4	7.0	3.6	1.6	8.0	12.0	Q1
TLC7701QPWRQ1	TSSOP	PW	8	2500	330.0	12.4	7.0	3.6	1.6	8.0	12.0	Q1
TLC7705QPWRG4Q1	TSSOP	PW	8	2000	330.0	12.4	7.0	3.6	1.6	8.0	12.0	Q1
TLC7733QPWRG4Q1	TSSOP	PW	8	2000	330.0	12.4	7.0	3.6	1.6	8.0	12.0	Q1
TLC7733QPWRQ1	TSSOP	PW	8	2000	330.0	12.4	7.0	3.6	1.6	8.0	12.0	Q1

TAPE AND REEL BOX DIMENSIONS

*All dimensions are nominal

Device	Package Type	Package Drawing	Pins	SPQ	Length (mm)	Width (mm)	Height (mm)
TLC7701QPWRG4Q1	TSSOP	PW	8	2000	367.0	367.0	35.0
TLC7701QPWRQ1	TSSOP	PW	8	2500	367.0	367.0	35.0
TLC7705QPWRG4Q1	TSSOP	PW	8	2000	367.0	367.0	35.0
TLC7733QPWRG4Q1	TSSOP	PW	8	2000	367.0	367.0	35.0
TLC7733QPWRQ1	TSSOP	PW	8	2000	367.0	367.0	35.0

EXAMPLE BOARD LAYOUT

PW0008A

TSSOP - 1.2 mm max height

SMALL OUTLINE PACKAGE

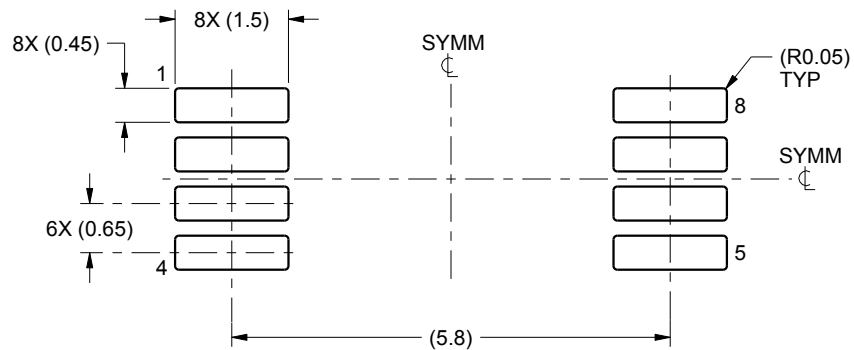

LAND PATTERN EXAMPLE
SCALE:10X

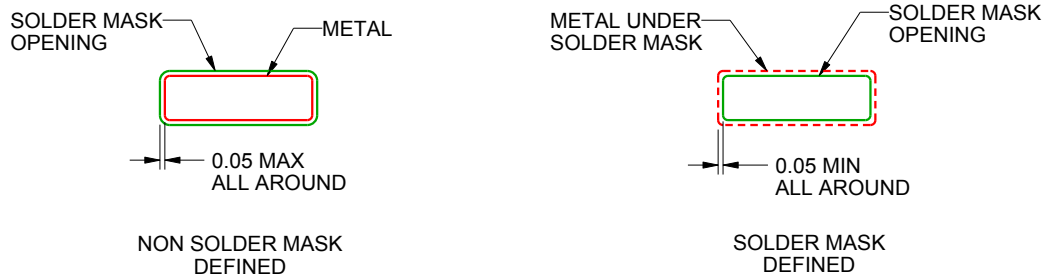

SOLDER MASK DETAILS
NOT TO SCALE

4221848/A 02/2015

NOTES: (continued)

- 6. Publication IPC-7351 may have alternate designs.
- 7. Solder mask tolerances between and around signal pads can vary based on board fabrication site.

EXAMPLE STENCIL DESIGN

PW0008A

TSSOP - 1.2 mm max height

SMALL OUTLINE PACKAGE



SOLDER PASTE EXAMPLE
BASED ON 0.125 mm THICK STENCIL
SCALE:10X

4221848/A 02/2015

NOTES: (continued)

8. Laser cutting apertures with trapezoidal walls and rounded corners may offer better paste release. IPC-7525 may have alternate design recommendations.
9. Board assembly site may have different recommendations for stencil design.

IMPORTANT NOTICE AND DISCLAIMER

TI PROVIDES TECHNICAL AND RELIABILITY DATA (INCLUDING DATASHEETS), DESIGN RESOURCES (INCLUDING REFERENCE DESIGNS), APPLICATION OR OTHER DESIGN ADVICE, WEB TOOLS, SAFETY INFORMATION, AND OTHER RESOURCES "AS IS" AND WITH ALL FAULTS, AND DISCLAIMS ALL WARRANTIES, EXPRESS AND IMPLIED, INCLUDING WITHOUT LIMITATION ANY IMPLIED WARRANTIES OF MERCHANTABILITY, FITNESS FOR A PARTICULAR PURPOSE OR NON-INFRINGEMENT OF THIRD PARTY INTELLECTUAL PROPERTY RIGHTS.

These resources are intended for skilled developers designing with TI products. You are solely responsible for (1) selecting the appropriate TI products for your application, (2) designing, validating and testing your application, and (3) ensuring your application meets applicable standards, and any other safety, security, or other requirements. These resources are subject to change without notice. TI grants you permission to use these resources only for development of an application that uses the TI products described in the resource. Other reproduction and display of these resources is prohibited. No license is granted to any other TI intellectual property right or to any third party intellectual property right. TI disclaims responsibility for, and you will fully indemnify TI and its representatives against, any claims, damages, costs, losses, and liabilities arising out of your use of these resources.

TI's products are provided subject to TI's Terms of Sale (www.ti.com/legal/termsofsale.html) or other applicable terms available either on ti.com or provided in conjunction with such TI products. TI's provision of these resources does not expand or otherwise alter TI's applicable warranties or warranty disclaimers for TI products.

Mailing Address: Texas Instruments, Post Office Box 655303, Dallas, Texas 75265
Copyright © 2019, Texas Instruments Incorporated

Looking for pricing, stock, or lifecycle information?

Click below to explore more details on WIN SOURCE:

 [View TLC7733QPWRQ1 on WIN SOURCE](#)

 [Texas Instruments](#) Information

Optimize Your Supply Chain with WIN SOURCE Solutions

-  Global Sourcing Solution
-  Obsolete Management
-  Cost Control Management
-  Shortage Management
-  Alternative Solution
-  Excess Inventory Management