



Package: DFN, 8-Pin, 2.0mmx2.0mmx0.6mm



**Features**

- SP3T Switch
- Switch Control Voltage 2.1to 5V (Typical 3.0V)
- Low Insertion Loss 0.8dB

**Applications**

- IEEE802.11b/g/n WLAN Applications
- WiFi/Bluetooth® Combination Devices

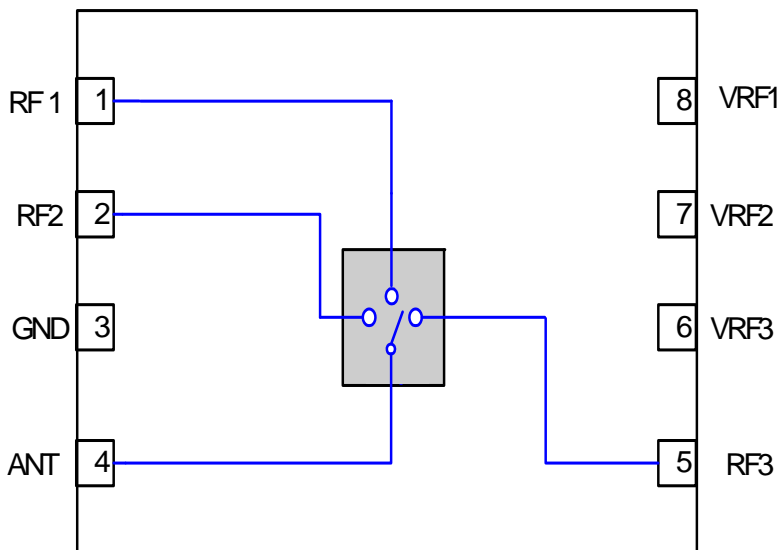

Functional Block Diagram

**Product Description**

The RF5500 is a SP3T switch designed for WLAN and WiFi/Bluetooth® applications in the 2.4GHz to 2.5GHz ISM band. The RF5500 is capable of switching between WLAN RX, WLAN TX, and Bluetooth® RX/TX operations. This switch can also be placed in WLAN and Bluetooth® receive modes simultaneously with a slight increase in insertion loss. The RF5500 is provided in a DFN 8-pin 2mmx2mmx0.6mm Pb-Free package. This device meets or exceeds the RF switch needs of IEEE802.11b/g/n RF systems.

**Ordering Information**

RF5500                      11b/g/n WLAN SP3T Switch  
RF5500PCBK-410      Fully Assembled Evaluation Board and 5 loose pcs.

**Optimum Technology Matching® Applied**

- |                                      |                                      |  |                                   |
|--------------------------------------|--------------------------------------|--|-----------------------------------|
| <input type="checkbox"/> GaAs HBT    | <input type="checkbox"/> SiGe BiCMOS | <input checked="" type="checkbox"/> GaAs pHEMT | <input type="checkbox"/> GaN HEMT |
| <input type="checkbox"/> GaAs MESFET | <input type="checkbox"/> Si BiCMOS   | <input type="checkbox"/> Si CMOS               | <input type="checkbox"/> RF MEMS  |
| <input type="checkbox"/> InGaP HBT   | <input type="checkbox"/> SiGe HBT    | <input type="checkbox"/> Si BJT                | <input type="checkbox"/> LD MOS   |

RF MICRO DEVICES®, RFMD®, Optimum Technology Matching®, Enabling Wireless Connectivity™, PowerStar®, POLARIS™ TOTAL RADIO™ and UltimateBlue™ are trademarks of RFMD, LLC. BLUETOOTH is a trademark owned by Bluetooth SIG, Inc., U.S.A. and licensed for use by RFMD. All other trade names, trademarks and registered trademarks are the property of their respective owners. ©2006, RF Micro Devices, Inc.

## Absolute Maximum Ratings

Parameter	Rating	Unit
Supply Voltage	5	V
Ruggedness Output VSWR	10:1	
Stability Output VSWR	5:1	
ESD Human Body Model	TBD	V
ESD Device Model	TBD	V
Operating Temperature Range	-40 to +85	°C
Storage Temperature	-40 to +150	°C
Moisture Sensitivity Level	MSL2	



Caution! ESD sensitive device.

Exceeding any one or a combination of the Absolute Maximum Rating conditions may cause permanent damage to the device. Extended application of Absolute Maximum Rating conditions to the device may reduce device reliability. Specified typical performance or functional operation of the device under Absolute Maximum Rating conditions is not implied.

RoHS status based on EUDirective2002/95/EC (at time of this document revision).

The information in this publication is believed to be accurate and reliable. However, no responsibility is assumed by RF Micro Devices, Inc. ("RFMD") for its use, nor for any infringement of patents, or other rights of third parties, resulting from its use. No license is granted by implication or otherwise under any patent or patent rights of RFMD. RFMD reserves the right to change component circuitry, recommended application circuitry and specifications at any time without prior notice.

Parameter	Specification			Unit	Condition
	Min.	Typ.	Max.		
<b>2.4GHz to 2.5GHz Switch Transmit and Receive Parameters</b>					Unless otherwise noted the following conditions apply: Control voltage=2.8V, Temp=-40°C to +85°C, over frequency range, and over V <sub>CC</sub> range
Frequency	2.4		2.5	GHz	
Insertion Loss		0.8	1.0	dB	All ports
Noise Figure		0.8	1.0	dB	All ports
Insertion Loss		3.8	4.0	dB	RF1/RF2, RF1/RF3, and RF2/RF3 Modes
Noise Figure		3.8	4.0	dB	RF1/RF2, RF1/RF3, and RF2/RF3 Modes, Note 4
Passband Ripple	-0.2		+0.2	dB	
P1dB		28		dBm	3.1 or higher control voltage for 30dB min, 28typ. at 2.8V
Input Return Loss	15	18		dB	
Output Return Loss	15	18		dB	
Current Consumption		1	5	µA	Switch operating current
Port Impedance					All ports, Note 2
Input		50		Ω	Receive
Output		50		Ω	Transmit
Isolation	13	18		dB	RF1, RF2, & RF3 Mode
Switch Control Voltage					SW1, SW2, & SW3 pins
Low		0	0.2	V	
High	2.1	2.8	5.0	V	
Switch Control Speed		50		nsec	

Pin	Function	Description
1	RF1	RF port.
2	RF2	RF port.
3	GND	Ground connection.
4	ANT	Antenna port.
5	RF3	RF port.
6	VRF3	Switch control to enable RF3 to ANT port.
7	VRF2	Switch control to enable RF2 to ANT port.
8	VRF1	Switch control to enable RF1 to ANT port.

**Switch Control Logic**

Mode	VRF1	VRF2	VRF3	Condition
RF3	0	0	1	RF 3 port to ANT port
RF2	0	1	0	RF 2 port to ANT port
RF1	1	0	0	RF 1 port to ANT port

### Pin Out

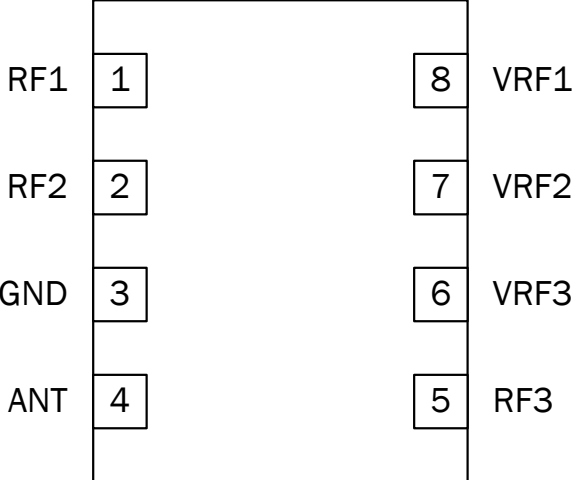

**Application Schematic**

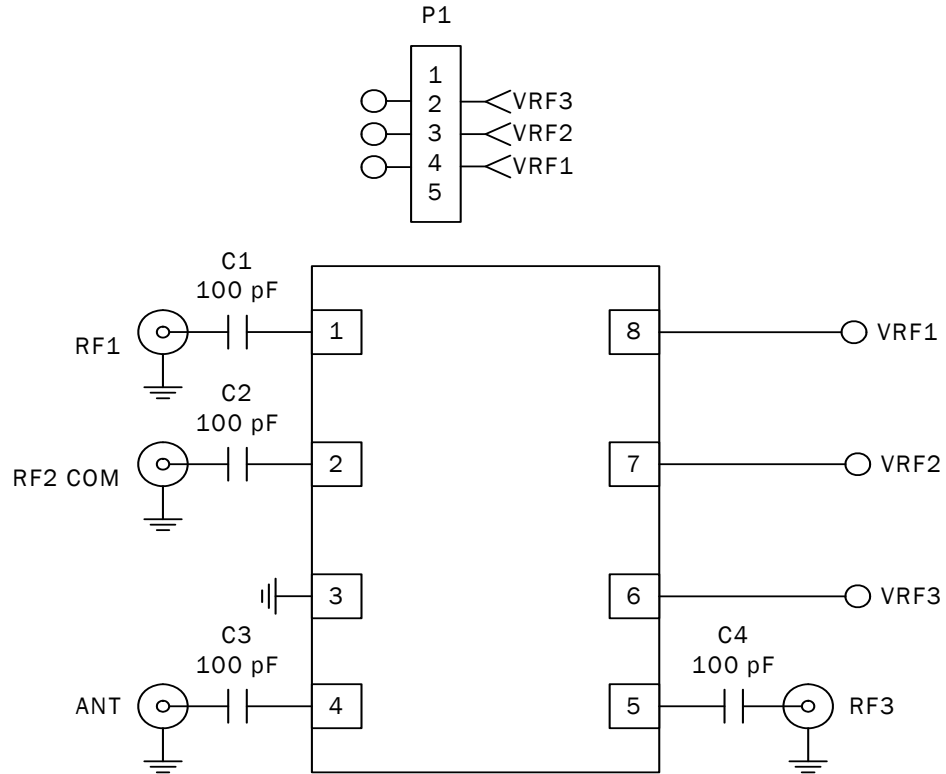

## Package Drawing DFN, 8-Pin, 2mmx2mmx0.55mm

Notes:  
1) PIN 1 INDICATOR SHADED AREA

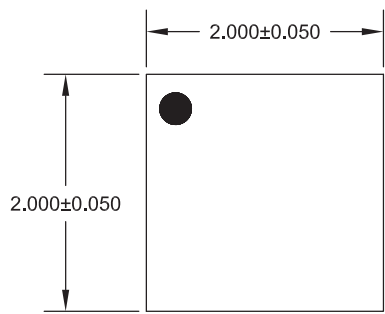

TOP VIEW

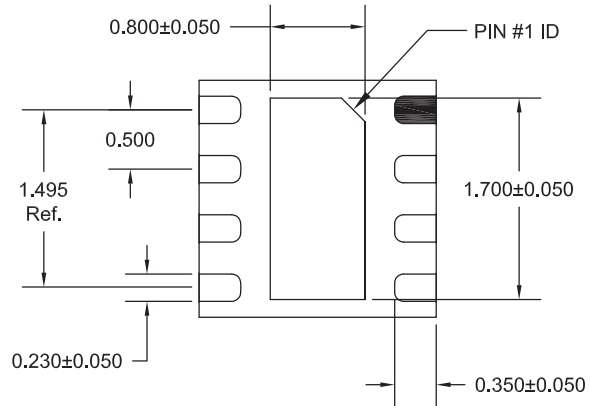

BOTTOM VIEW

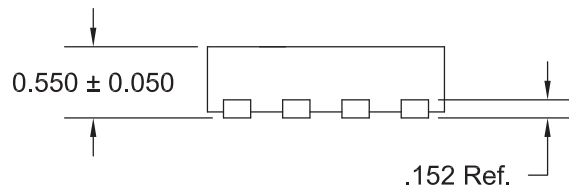

SIDE VIEW

### PCB Metal Land Pattern

A = 0.478 x 0.230 (mm) Typ  
B = 0.800 x 1.700 (mm)

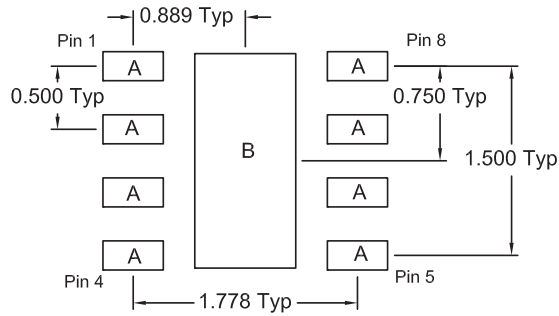

**PCB Solder Mask Pattern**

A = 0.578 x 0.330 (mm) Typ  
B = 0.900 x 1.800 (mm)

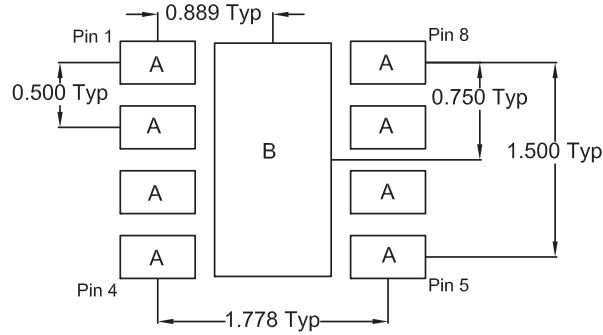

**PCB Stencil Pattern**

A = 0.430 x 0.207 (mm) Typ  
B = 0.720 x 1.530 (mm)

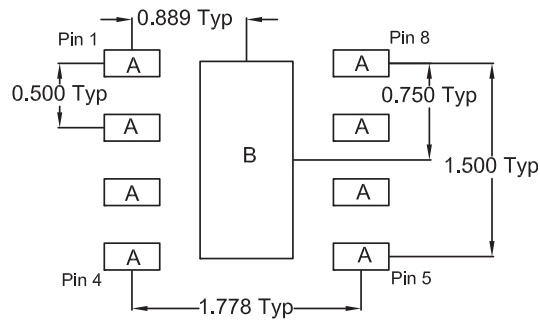



## Looking for pricing, stock, or lifecycle information?

Click below to explore more details on WIN SOURCE:

-  [View RF5500 on WIN SOURCE](#)
-  [RF Micro Devices Information](#)

## Optimize Your Supply Chain with WIN SOURCE Solutions

-  Global Sourcing Solution
-  Obsolete Management
-  Cost Control Management
-  Shortage Management
-  Alternative Solution
-  Excess Inventory Management