



THE DATASHEET OF STA501A13TR





45V 3.5A DOUBLE POWER HALF BRIDGE

1 FEATURES

- MULTIPOWER BCD TECHNOLOGY
- MINIMUM INPUT OUTPUT PULSE WIDTH DISTORTION
- 200mΩ R_{dsON} COMPLEMENTARY DMOS OUTPUT STAGE
- CMOS COMPATIBLE LOGIC INPUTS
- THERMAL PROTECTION
- THERMAL WARNING OUTPUT
- UNDER VOLTAGE PROTECTION

2 DESCRIPTION

STA501A is a monolithic dual half bridge stage in Multipower BCD Technology.

Figure 1. Package

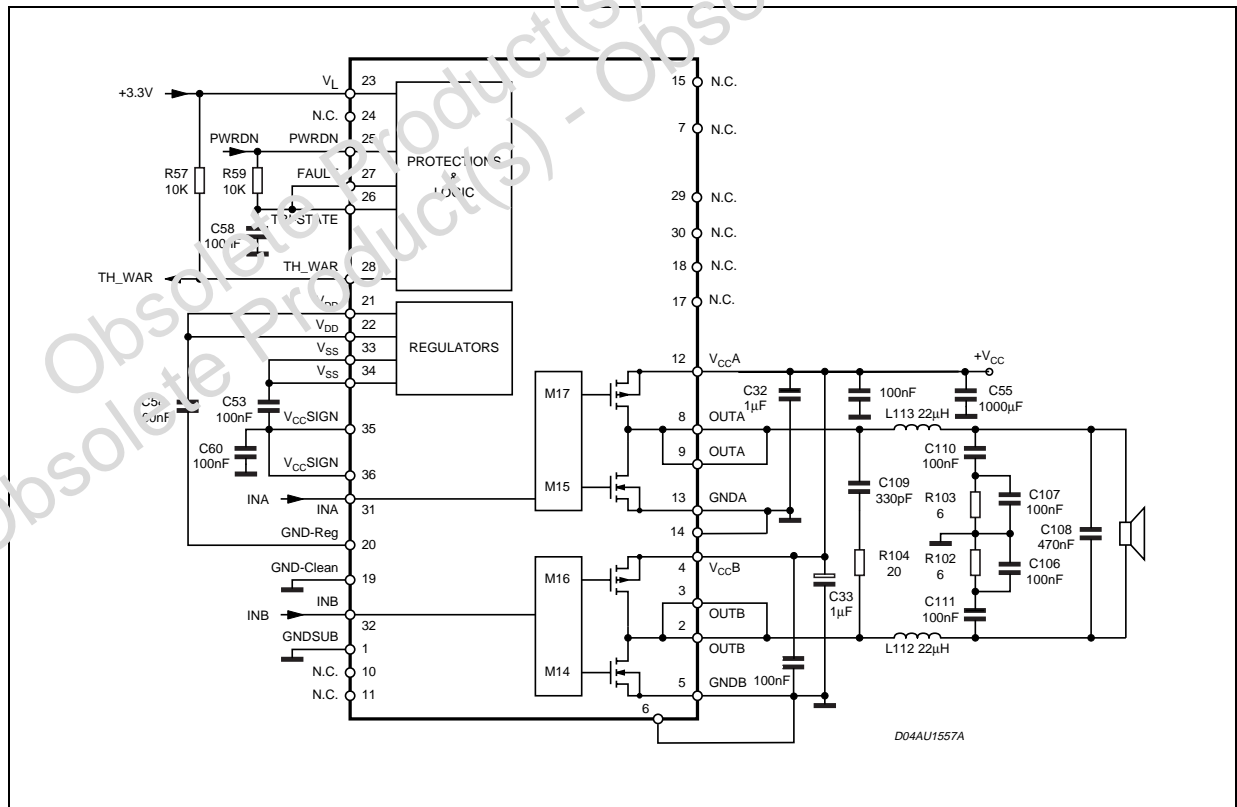

Table 1. Order Codes

Part Number	Package
STA501A	PowerSO36 (SLUG UP)

The device is particularly designed to make the output stage of a mono All-Digital High Efficiency (DDX™) amplifier capable to deliver 50W @ THD = 10% at V_{CC} 50V / output power on 8Ω load. The input pins have threshold proportional to V_L pin voltage.

Figure 2. Audio Application Circuit



STA501A

Table 2. PIN FUNCTION

N°	Pin	Description
1	GND-SUB	Substrate ground
2 ; 3	OUTB	Output half bridge
4	Vcc	Positive Supply
5	GND	Negative Supply
6	GND	Negative Supply
7	N.C.	Not Connected
8 ; 9	OUTA	Output half bridge
10 ; 11	N.C.	Not Connected
12	Vcc	Positive Supply
13	GND	Negative Supply
14	GND	Negative Supply
15	N.C.	Not Connected
16 ; 17	N.C.	Not Connected
18	N.C.	Not connected
19	GND-clean	Logical ground
20	GND-Reg	Ground for regulator Vdd
21 ; 22	Vdd	5V Regulator referred to ground
23	V _L	High logical state setting voltage
24	N.C.	Not Connected
25	PWRDN	Stand-by pin
26	TRI-STABLE	High-Z pin
27	FAULT	Fault pin advisor
28	TH-WAR	Thermal warning advisor
29	N.C.	Not Connected
30	N.C.	Not Connected
31	INA	Input of half bridge
32	INB	Input of half bridge
33 ; 34	Vss	5V Regulator referred to +Vcc
35 ; 36	Vcc Sign	Signal Positive Supply

Figure 3. FUNCTIONAL PIN STATUS

PIN NAME	Logical value	IC -STATUS
FAULT	0	Fault detected (Short circuit, or Thermal ..)
FAULT *	1	Normal Operation
TRI-STATE	0	All powers in High-Z state
TRI-STATE	1	Normal operation
PWRDN	0	Low absorption
PWRDN	1	Normal operation
THWAR	0	Temperature of the IC =130C
THWAR*	1	Normal operation

* : The pin is open collector. To have the high logic value, it needs to be pulled up by a resistor.

Figure 4. PIN CONNECTION

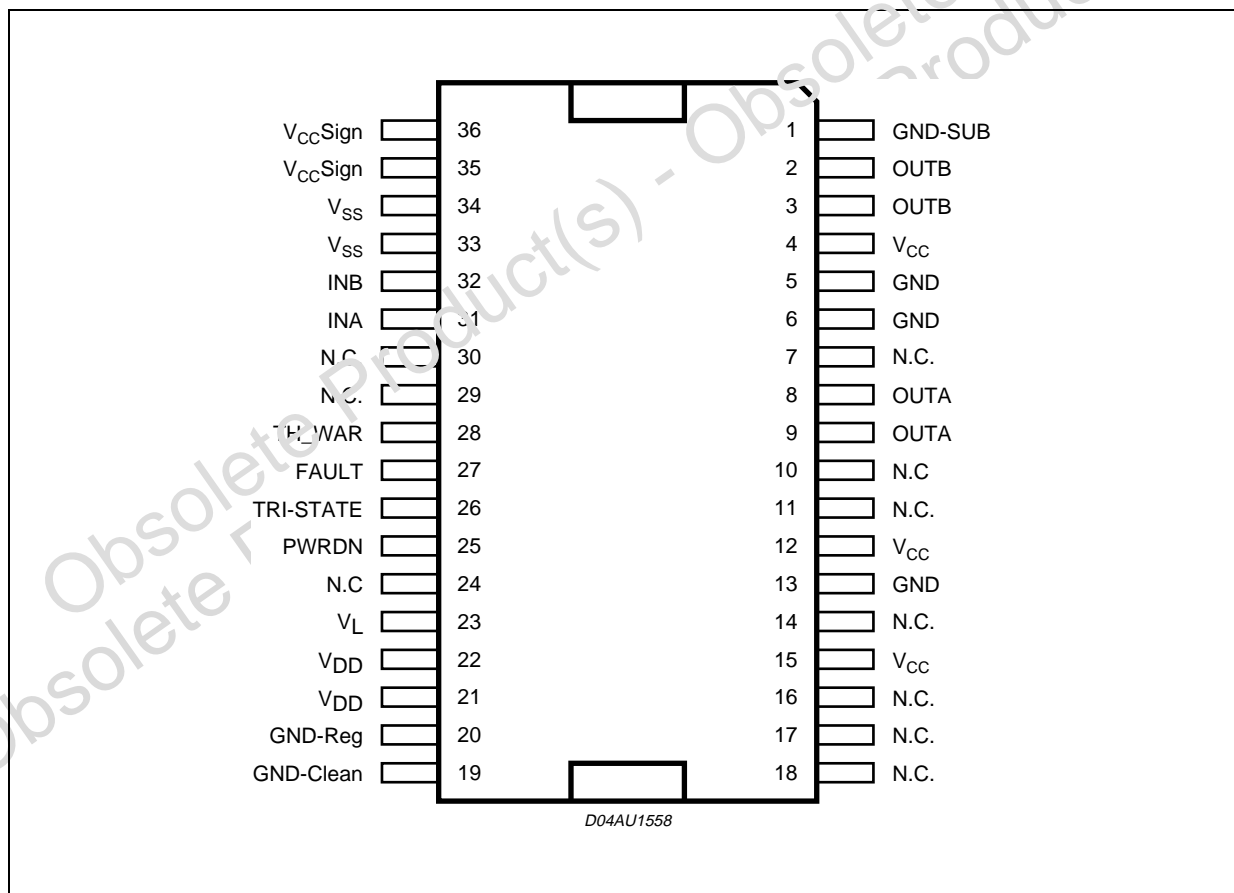

Table 3. ABSOLUTE MAXIMUM RATINGS

Symbol	Parameter	Value	Unit
V _{CC}	DC Supply Voltage (Pin 4,7,12,15)	45	V
V _{max}	Maximum Voltage on pins 23 to 32	5.5	V
T _{op}	Operating Temperature Range	0 to 70	°C
T _{stg} , T _j	Storage and Junction Temperature	-40 to 150	°C

Table 4. THERMAL DATA

Symbol	Parameter	Min.	Typ.	Max.	Unit
T _{J-case}	Thermal Resistance Junction to Case (thermal pad)			2.5	°C/W
T _{JSD}	Thermal shut-down junction temperature		150		°C
T _{warn}	Thermal warning temperature		130		°C
t _{hSD}	Thermal shut-down hysteresis		25		°C

Table 5. ELECTRICAL CHARACTERISTICS (V_L = 3.3V; V_{CC} = 30V; T_{amb} = 25°C unless otherwise specified)

Symbol	Parameter	Test conditions	Min.	Typ.	Max.	Unit
R _{dsON}	Power Pchannel/Nchannel MOSFET RdsON	I _d =1A		200	270	mΩ
I _{dss}	Power Pchannel/Nchannel leakage I _{dss}	V _{CC} =35V			50	μA
g _N	Power Pchannel RdsON Matching	I _d =1A	95			%
g _P	Power Nchannel RdsON Matching	I _d =1A	95			%
Dt _s	Low current Dead Time (static)	see test circuit no.1; see fig. 5		10	20	ns
Dt _d	High current Dead Time (dynamic)	L=22μH; C = 470nF; R _L = 8 Ω I _d =3.5A; see fig. 7			50	ns
t _{ON}	Turn-on delay time	Resistive load			100	ns
t _{d OFF}	Turn-off delay time	Resistive load			100	ns
t _r	Rise time	Resistive load			25	ns
t _f	Fall time	Resistive load; as fig. 5			25	ns
V _{CC}	Supply voltage operating voltage		10		40	V
V _{IN-High}	High level input voltage				V _L /2 +300mV	V
V _{IN-Low}	Low level input voltage		V _L /2 - 300mV			V
I _{IN-H}	High level Input current	Pin voltage = V _L		1		μA

Table 5. ELECTRICAL CHARACTERISTICS (continued)

Symbol	Parameter	Test conditions	Min.	Typ.	Max.	Unit
I_{IN-L}	Low level input current	Pin voltage = 0.3V		1		μA
$I_{PWRDN-H}$	High level PWRDN pin input current	$V_L = 3.3V$		35		μA
V_{Low}	Low logical state voltage V_{Low} (pin PWRDN, TRISTATE) (note 1)	$V_L = 3.3V$	0.8			V
V_{High}	High logical state voltage V_{High} (pin PWRDN, TRISTATE) (note 1)	$V_L = 3.3V$			1.7	V
$I_{VCC-PWRDN}$	Supply Current from V_{cc} in Power Down	$PWRDN = 0$			3	mA
I_{FAULT}	Output Current pins FAULT -TH-WARN when FAULT CONDITIONS	$V_{pin} = 3.3V$		1		mA
$I_{VCC-hiz}$	Supply current from V_{cc} in Tri-state	$V_{cc}=30V$; Tri-state=0		22		mA
I_{VCC}	Supply current from V_{cc} in operation (both channel switching)	Input pulse width = 50% Duty; Switching Frequency = 384KHz; No LC filters;		50		mA
I_{out-sh}	Overcurrent protection threshold (short circuit current limit)		3.5	6	8	A
V_{UV}	Undervoltage protection threshold			7		V
t_{pw-min}	Output minimum pulse width	No Load	70		150	ns

Table 6.

V_L	V_{Low} min	V_{High} max	Unit
2.7	0.7	1.5	V
3.3	0.8	1.7	V
5	0.85	1.85	V

Note : 1. The following table explains the V_{Low} , V_{High} variation with V_L

Table 7. LOGIC TRUTH (see fig. 6)

TRI-STATE	INA	INB	Q1	Q2	Q3	Q4	OUTPUT MODE
0	x	x	OFF	OFF	OFF	OFF	Hi-Z
1	0	0	OFF	OFF	ON	ON	DUMP
1	0	1	OFF	ON	ON	OFF	NEGATIVE
1	1	0	ON	OFF	OFF	ON	POSITIVE
1	1	1	ON	ON	OFF	OFF	Not used

Figure 5. Test Circuit.

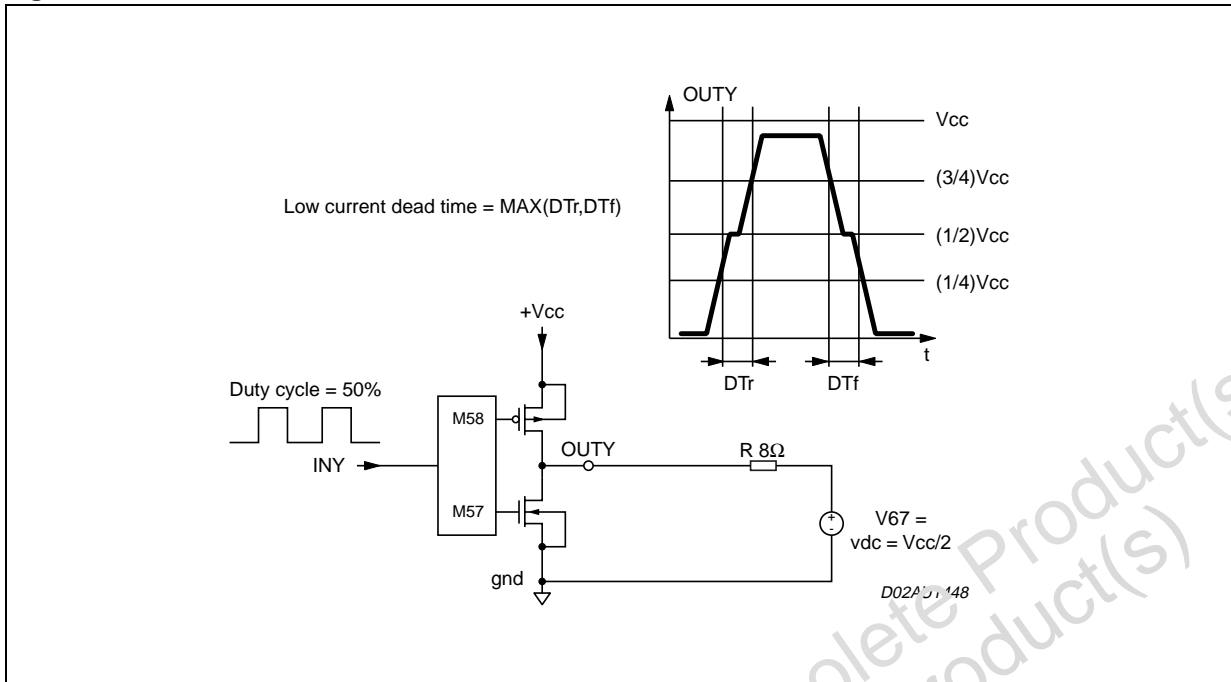

Figure 6.

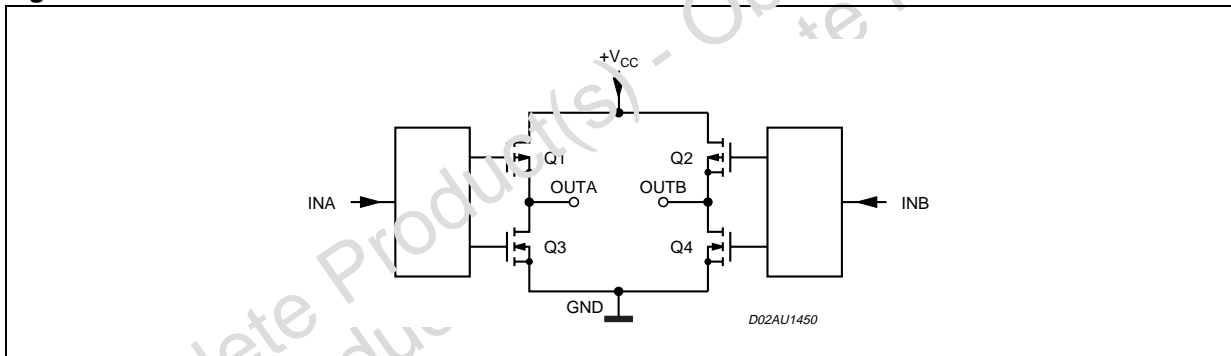

Figure 7.

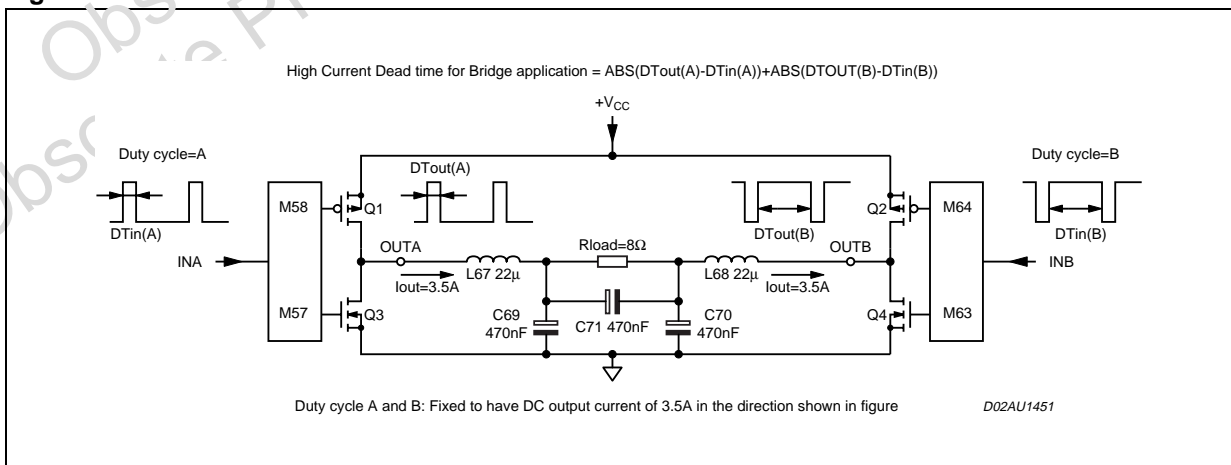
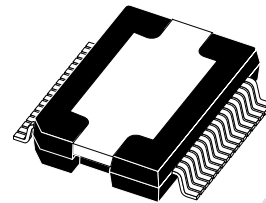

Figure 8. PowerSO36 (SLUG UP) Mechanical Data & Package Dimensions

DIM.	mm			inch		
	MIN.	TYP.	MAX.	MIN.	TYP.	MAX.
A	3.25		3.43	0.128		0.135
A2	3.1		3.2	0.122		0.126
A4	0.8		1	0.031		0.039
A5		0.2			0.008	
a1	0.030		-0.040	0.0011		-0.0015
b	0.22		0.38	0.008		0.015
c	0.23		0.32	0.009		0.012
D	15.8		16	0.622		0.630
D1	9.4		9.8	0.37		0.38
D2		1			0.039	
E	13.9		14.5	0.547		0.57
E1	10.9		11.1	0.429		0.437
E2			2.9			0.114
E3	5.8		6.2	0.228		0.244
E4	2.9		3.2	0.114		1.259
e		0.65			0.026	
e3		11.05			0.435	
G	0		0.075	0		0.003
H	15.5		15.9	0.61		0.625
h			1.1			0.043
L	0.8		1.1	0.031		0.043
N			10°			10°
s			8°			8°

OUTLINE AND MECHANICAL DATA



PowerSO36 (SLUG UP)

- (1) "D and E1" do not include mold flash or protusions. Mold flash or protusions shall not exceed 0.15mm (0.006")
- (2) No intrusion allowed inwards the leads.

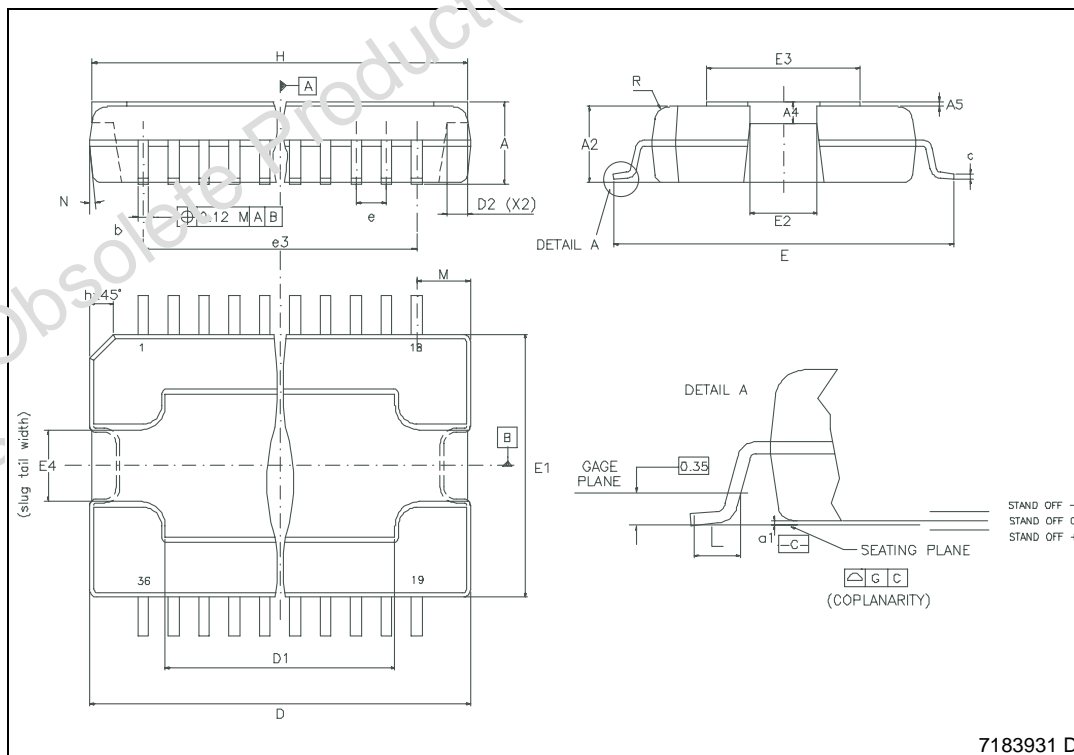

Table 8. Revision History

Date	Revision	Description of Changes
November 2004	1	First Issue

Obsolete Product(s) - Obsolete Product(s)
Obsolete Product(s) - Obsolete Product(s)

Information furnished is believed to be accurate and reliable. However, STMicroelectronics assumes no responsibility for the consequences of use of such information nor for any infringement of patents or other rights of third parties which may result from its use. No license is granted by implication or otherwise under any patent or patent rights of STMicroelectronics. Specifications mentioned in this publication are subject to change without notice. This publication supersedes and replaces all information previously supplied. STMicroelectronics products are not authorized for use as critical components in life support devices or systems without express written approval of STMicroelectronics.

The ST logo is a registered trademark of STMicroelectronics.
All other names are the property of their respective owners

DDX is a trademark of Apogee technology inc.

© 2004 STMicroelectronics - All rights reserved

STMicroelectronics group of companies
Australia - Belgium - Brazil - Canada - China - Czech Republic - Finland - France - Germany - Hong Kong - India - Israel - Italy - Japan -
Malaysia - Malta - Morocco - Singapore - Spain - Sweden - Switzerland - United Kingdom - United States of America
www.st.com

Looking for pricing, stock, or lifecycle information?

Click below to explore more details on WIN SOURCE:

- ⊖ [View STA501A13TR on WIN SOURCE](#)
- ⊖ [STMicroelectronics Information](#)

Optimize Your Supply Chain with WIN SOURCE Solutions

- ✓ Global Sourcing Solution
- ✓ Obsolete Management
- ✓ Cost Control Management
- ✓ Shortage Management
- ✓ Alternative Solution
- ✓ Excess Inventory Management