



**THE DATASHEET OF  
SI4706-D50-GMR**



## HIGH-PERFORMANCE FM AND RDS/RBDS RECEIVER

### Features

- Worldwide FM band support (76–108 MHz)
- Advanced patented RDS/RBDS decoding engine
- Lowest power consumption
- Outstanding RDS sensitivity, synchronization, and reliability
- Received signal quality indicators
- On-chip tuned resonance for embedded antenna support
- Multipath detection and mitigation
- FM Hi-cut control
- Advanced FM stereo-mono blend
- Automatic gain control (AGC)
- Integrated FM LNA
- Image-rejection mixer
- Frequency synthesizer with integrated VCO
- Low-IF direct conversion with no external ceramic filters
- 2.7 to 5.5 V supply voltage
- Dual 1.8 and 2.7 V power supplies
- Stereo audio out
- I<sup>2</sup>S Digital audio out
- 20-pin 3 x 3 mm QFN package
  - Pb-free/RoHS compliant

### Applications

- Cellular handsets
- Portable media devices
- Dedicated data receiver
- Personal navigation devices (PND)
- GPS-enabled handsets and portable devices

### Description

The Si4706-D50 FM/RDS/RBDS receiver provides the highest performance and lowest power consumption available for portable devices today. The 100% CMOS IC integrates the complete FM and data receiver function from antenna to analog or digital audio and data out in a single 3 x 3 mm 20-pin QFN.

### Functional Block Diagram

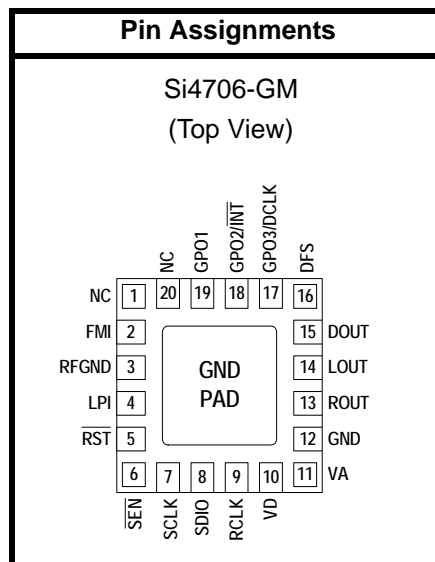
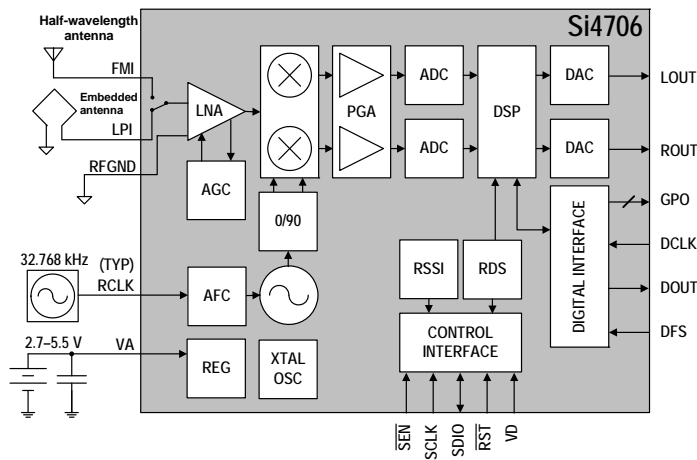

This product, its features, and/or its architecture is covered by one or more of the following patents, as well as other patents, pending and issued, both foreign and domestic: 7,127,217; 7,272,373; 7,272,375; 7,321,324; 7,355,476; 7,426,376; 7,471,940; 7,339,503; 7,339,504.



---

**TABLE OF CONTENTS**

---

<b><u>Section</u></b>	<b><u>Page</u></b>
<b>1. Electrical Specifications</b> .....	<b>4</b>
<b>2. Typical Application Schematic</b> .....	<b>15</b>
<b>3. Bill of Materials</b> .....	<b>16</b>
<b>4. Functional Description</b> .....	<b>17</b>
4.1. Overview .....	17
4.2. FM Receiver .....	18
4.3. Stereo Audio Processing .....	18
4.4. Received Signal Qualifiers .....	18
4.5. De-emphasis .....	19
4.6. Stereo DAC .....	19
4.7. Soft Mute .....	19
4.8. FM Hi-Cut Control .....	19
4.9. Tuning .....	19
4.10. Seek .....	19
4.11. Digital Audio Interface .....	20
4.12. Embedded Antenna Support .....	22
4.13. RDS Decoder .....	23
4.14. Reference Clock .....	24
4.15. Control Interface .....	25
4.16. GPO Outputs .....	26
4.17. Reset, Powerup, and Powerdown .....	26
4.18. Programming with Commands .....	26
<b>5. Commands and Properties</b> .....	<b>27</b>
<b>6. Pin Descriptions: Si4706-GM</b> .....	<b>28</b>
<b>7. Ordering Guide</b> .....	<b>29</b>
<b>8. Package Markings</b> .....	<b>30</b>
8.1. Si4706 Top Mark .....	30
8.2. Top Mark Explanation .....	30
<b>9. Package Outline: Si4706 QFN</b> .....	<b>31</b>
<b>10. PCB Land Pattern: Si4706 QFN</b> .....	<b>32</b>
<b>11. Additional Reference Resources</b> .....	<b>34</b>
<b>Document Change List</b> .....	<b>35</b>
<b>Contact Information</b> .....	<b>36</b>

# Si4706-D50

## 1. Electrical Specifications

Table 1. Recommended Operating Conditions\*

Parameter	Symbol	Test Condition	Min	Typ	Max	Unit
Analog Supply Voltage	$V_A$		2.7	—	5.5	V
Digital and Interface Supply Voltage	$V_D$		1.62	—	3.6	V
Analog Power Supply Powerup Rise Time	$V_{ARISE}$		10	—	—	$\mu$ s
Digital Power Supply Powerup Rise Time	$V_{DRISE}$		10	—	—	$\mu$ s
Ambient Temperature	$T_A$		-20	25	85	$^{\circ}$ C

\*Note: All minimum and maximum specifications are guaranteed and apply across the recommended operating conditions. Typical values apply at  $V_A = 3.3$  V and  $25$   $^{\circ}$ C unless otherwise stated. Parameters are tested in production unless otherwise stated.

Table 2. Absolute Maximum Ratings<sup>1,2</sup>

Parameter	Symbol	Value	Unit
Analog Supply Voltage	$V_A$	-0.5 to 5.8	V
Digital and Interface Supply Voltage	$V_D$	-0.5 to 3.9	V
Input Current <sup>3</sup>	$I_{IN}$	10	mA
Input Voltage <sup>3</sup>	$V_{IN}$	-0.3 to ( $V_{IO} + 0.3$ )	V
Operating Temperature	$T_{OP}$	-40 to 95	$^{\circ}$ C
Storage Temperature	$T_{STG}$	-55 to 150	$^{\circ}$ C
RF Input Level <sup>4</sup>		0.4	$V_{pK}$

**Notes:**

1. Permanent device damage may occur if the above Absolute Maximum Ratings are exceeded. Functional operation should be restricted to the conditions as specified in the operational sections of this data sheet. Exposure beyond recommended operating conditions for extended periods may affect device reliability.
2. The Si4706 device is a high-performance RF integrated circuit with certain pins having an ESD rating of < 2 kV HBM. Handling and assembly of these devices should only be done at ESD-protected workstations.
3. For input pins DFS, SCLK, SEN, SDIO, RST, RCLK, GPO1, GPO2, and GPO3.
4. At RF input pins FMI and LPI.

**Table 3. DC Characteristics**(V<sub>A</sub> = 2.7 to 5.5 V, V<sub>D</sub> = 1.62 to 3.6 V, T<sub>A</sub> = -20 to 85 °C)

Parameter	Symbol	Test Condition	Min	Typ	Max	Unit
<b>FM Receiver to Line Output</b>						
V <sub>A</sub> Supply Current	I <sub>FMVA</sub>	Digital Output Mode	—	7.5	8.6	mA
V <sub>A</sub> Supply Current		Analog Output Mode	—	8.8	9.7	mA
V <sub>D</sub> Supply Current	I <sub>FMID</sub>	Digital Output Mode	—	8.5	11.1	mA
V <sub>D</sub> Supply Current	I <sub>FMID</sub>	Analog Output Mode	—	8.4	11.1	mA
<b>Supplies and Interface</b>						
V <sub>A</sub> Powerdown Current	I <sub>DDPD</sub>		—	4	15	μA
V <sub>D</sub> Powerdown Current	I <sub>IOPD</sub>	SCLK, RCLK inactive	—	3	10	μA
High Level Input Voltage <sup>1</sup>	V <sub>IH</sub>		0.7 x V <sub>D</sub>	—	V <sub>D</sub> + 0.3	V
Low Level Input Voltage <sup>1</sup>	V <sub>IL</sub>		-0.3	—	0.3 x V <sub>D</sub>	V
High Level Input Current <sup>1</sup>	I <sub>IH</sub>	V <sub>IN</sub> = V <sub>D</sub> = 3.6 V	-10	—	10	μA
Low Level Input Current <sup>1</sup>	I <sub>IL</sub>	V <sub>IN</sub> = 0 V, V <sub>D</sub> = 3.6 V	-10	—	10	μA
High Level Output Voltage <sup>2</sup>	V <sub>OH</sub>	I <sub>OUT</sub> = 500 μA	0.8 x V <sub>D</sub>	—	—	V
Low Level Output Voltage <sup>2</sup>	V <sub>OL</sub>	I <sub>OUT</sub> = -500 μA	—	—	0.2 x V <sub>D</sub>	V
<b>Notes:</b>						
1. For input pins SCLK, SEN, SDIO, RST, RCLK, DCLK, DFS, GPO1, GPO2, and GPO3.						
2. For output pins SDIO, DOUT, GPO1, GPO2, and GPO3.						

# Si4706-D50

**Table 4. Reset Timing Characteristics<sup>1,2,3</sup>**

( $V_A = 2.7$  to  $5.5$  V,  $V_D = 1.62$  to  $3.6$  V,  $T_A = -20$  to  $85$  °C)

Parameter	Symbol	Min	Typ	Max	Unit
$\overline{\text{RST}}$ Pulse Width and GPO1, GPO2/ $\overline{\text{INT}}$ Setup to $\overline{\text{RST}}\uparrow^4$	$t_{\text{SRST}}$	100	—	—	$\mu\text{s}$
GPO1, GPO2/ $\overline{\text{INT}}$ Hold from $\overline{\text{RST}}\uparrow$	$t_{\text{HRST}}$	30	—	—	ns

**Important Notes:**

1. When selecting 2-wire mode, the user must ensure that a 2-wire start condition (falling edge of SDIO while SCLK is high) does not occur within 300 ns before the rising edge of  $\overline{\text{RST}}$ .
2. When selecting 2-wire mode, the user must ensure that SCLK is high during the rising edge of  $\overline{\text{RST}}$ , and stays high until after the first start condition.
3. When selecting 3-wire mode, the user must ensure that a rising edge of SCLK does not occur within 300 ns before the rising edge of  $\overline{\text{RST}}$ .
4. If GPO1 and GPO2 are actively driven by the user, then minimum  $t_{\text{SRST}}$  is only 30 ns. If GPO1 or GPO2 is high impedance, then minimum  $t_{\text{SRST}}$  is 100  $\mu\text{s}$  to provide time for on-chip 1 M $\Omega$  devices (active while  $\overline{\text{RST}}$  is low) to pull GPO1 high and GPO2 low.

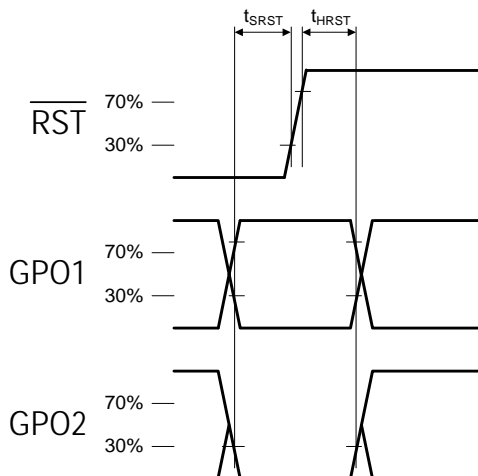

**Figure 1. Reset Timing Parameters for Busmode Select Method**

**Table 5. 2-Wire Control Interface Characteristics<sup>1,2,3</sup>**(V<sub>A</sub> = 2.7 to 5.5 V, V<sub>D</sub> = 1.62 to 3.6 V, T<sub>A</sub> = -20 to 85 °C)

Parameter	Symbol	Test Condition	Min	Typ	Max	Unit
SCLK Frequency	f <sub>SCL</sub>		0	—	400	kHz
SCLK Low Time	t <sub>LOW</sub>		1.3	—	—	μs
SCLK High Time	t <sub>HIGH</sub>		0.6	—	—	μs
SCLK Input to SDIO ↓ Setup (START)	t <sub>SU:STA</sub>		0.6	—	—	μs
SCLK Input to SDIO ↓ Hold (START)	t <sub>HD:STA</sub>		0.6	—	—	μs
SDIO Input to SCLK ↑ Setup	t <sub>SU:DAT</sub>		100	—	—	ns
SDIO Input to SCLK ↓ Hold <sup>4, 5</sup>	t <sub>HD:DAT</sub>		0	—	900	ns
SCLK Input to SDIO ↑ Setup (STOP)	t <sub>SU:STO</sub>		0.6	—	—	μs
STOP to START Time	t <sub>BUF</sub>		1.3	—	—	μs
SDIO Output Fall Time	t <sub>f:OUT</sub>		$20 + 0.1 \frac{C_b}{1\text{pF}}$	—	250	ns
SDIO Input, SCLK Rise/Fall Time	t <sub>f:IN</sub> t <sub>r:IN</sub>		$20 + 0.1 \frac{C_b}{1\text{pF}}$	—	300	ns
SCLK, SDIO Capacitive Loading	C <sub>b</sub>		—	—	50	pF
Input Filter Pulse Suppression	t <sub>SP</sub>		—	—	50	ns

**Notes:**

1. When V<sub>D</sub> = 0 V, SCLK and SDIO are low impedance.
2. When selecting 2-wire mode, the user must ensure that a 2-wire start condition (falling edge of SDIO while SCLK is high) does not occur within 300 ns before the rising edge of  $\overline{\text{RST}}$ .
3. When selecting 2-wire mode, the user must ensure that SCLK is high during the rising edge of  $\overline{\text{RST}}$ , and stays high until after the first start condition.
4. The Si4706 delays SDIO by a minimum of 300 ns from the V<sub>IH</sub> threshold of SCLK to comply with the minimum t<sub>HD:DAT</sub> specification.
5. The maximum t<sub>HD:DAT</sub> has only to be met when f<sub>SCL</sub> = 400 kHz. At frequencies below 400 kHz, t<sub>HD:DAT</sub> may be violated as long as all other timing parameters are met.

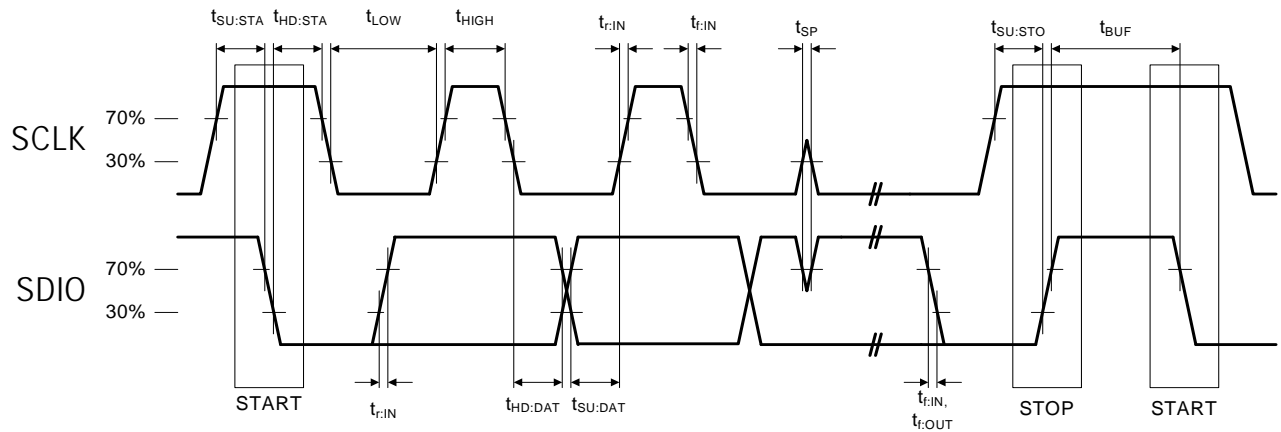

**Figure 2. 2-Wire Control Interface Read and Write Timing Parameters**

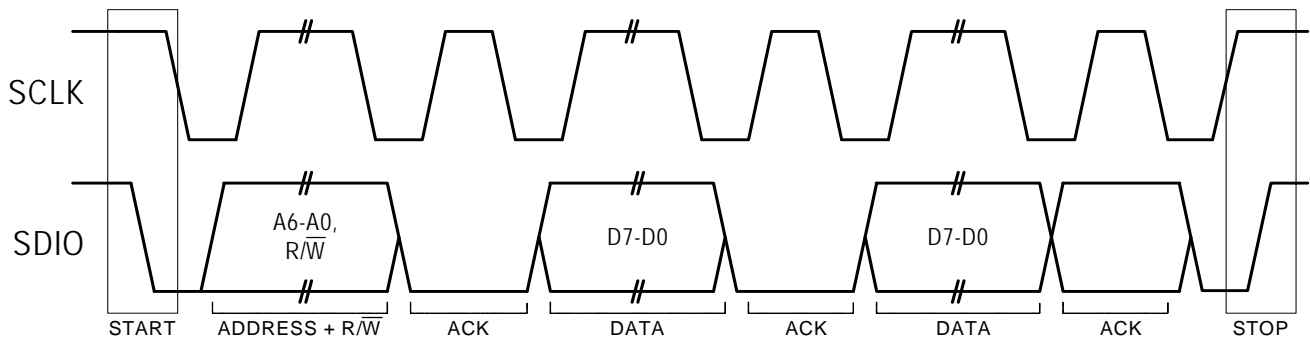

**Figure 3. 2-Wire Control Interface Read and Write Timing Diagram**

**Table 6. 3-Wire Control Interface Characteristics** $(V_A = 2.7 \text{ to } 5.5 \text{ V}, V_D = 1.62 \text{ to } 3.6 \text{ V}, T_A = -20 \text{ to } 85 \text{ }^\circ\text{C})$ 

Parameter	Symbol	Test Condition	Min	Typ	Max	Unit
SCLK Frequency	$f_{\text{CLK}}$		0	—	2.5	MHz
SCLK High Time	$t_{\text{HIGH}}$		25	—	—	ns
SCLK Low Time	$t_{\text{LOW}}$		25	—	—	ns
SDIO Input, $\overline{\text{SEN}}$ to SCLK $\uparrow$ Setup	$t_s$		20	—	—	ns
SDIO Input to SCLK $\uparrow$ Hold	$t_{\text{HSDIO}}$		10	—	—	ns
$\overline{\text{SEN}}$ Input to SCLK $\downarrow$ Hold	$t_{\text{HSEN}}$		10	—	—	ns
SCLK $\uparrow$ to SDIO Output Valid	$t_{\text{CDV}}$	Read	2	—	25	ns
SCLK $\uparrow$ to SDIO Output High Z	$t_{\text{CDZ}}$	Read	2	—	25	ns
SCLK, $\overline{\text{SEN}}$ , SDIO, Rise/Fall Time	$t_R, t_F$		—	—	10	ns

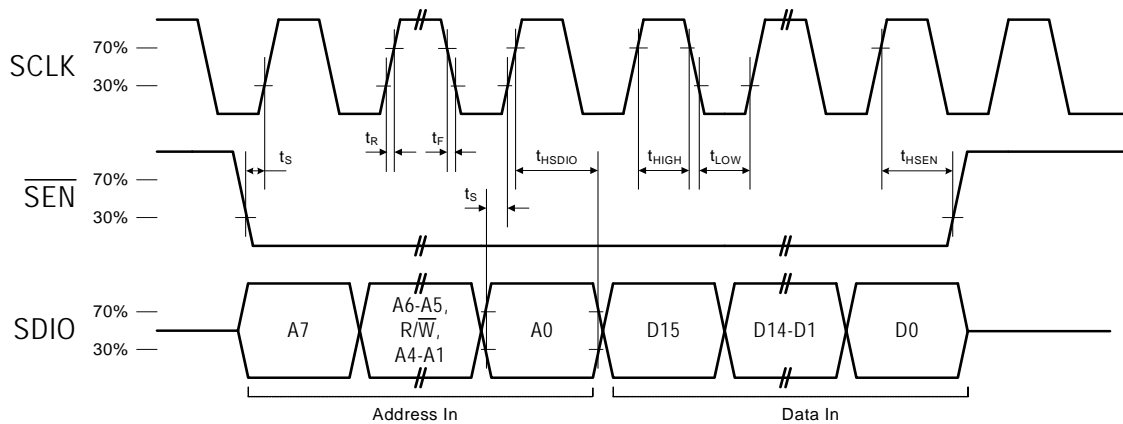
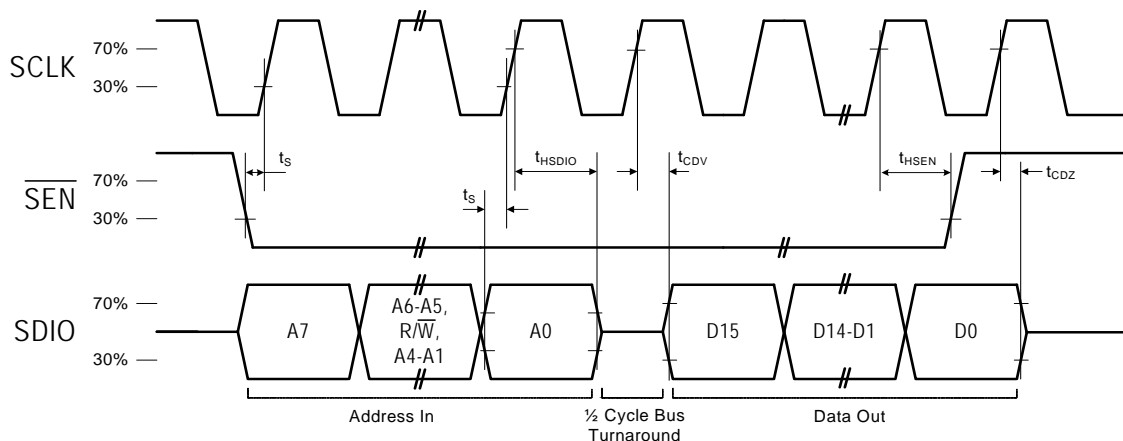
**Figure 4. 3-Wire Control Interface Write Timing Parameters****Figure 5. 3-Wire Control Interface Read Timing Parameters**

# Si4706-D50

**Table 7. Digital Audio Interface Characteristics**

( $V_A = 2.7$  to  $5.5$  V,  $V_D = 1.62$  to  $3.6$  V,  $T_A = -20$  to  $85$  °C)

Parameter	Symbol	Test Condition	Min	Typ	Max	Unit
DCLK Cycle Time	$t_{DCT}$		26	—	1000	ns
DCLK Pulse Width High	$t_{DCH}$		10	—	—	ns
DCLK Pulse Width Low	$t_{DCL}$		10	—	—	ns
DFS Setup Time to DCLK Rising Edge	$t_{SU:DFS}$		5	—	—	ns
DFS Hold Time from DCLK Rising Edge	$t_{HD:DFS}$		5	—	—	ns
DOUT Propagation Delay from DCLK Falling Edge	$t_{PD:DOUT}$		0	—	12	ns

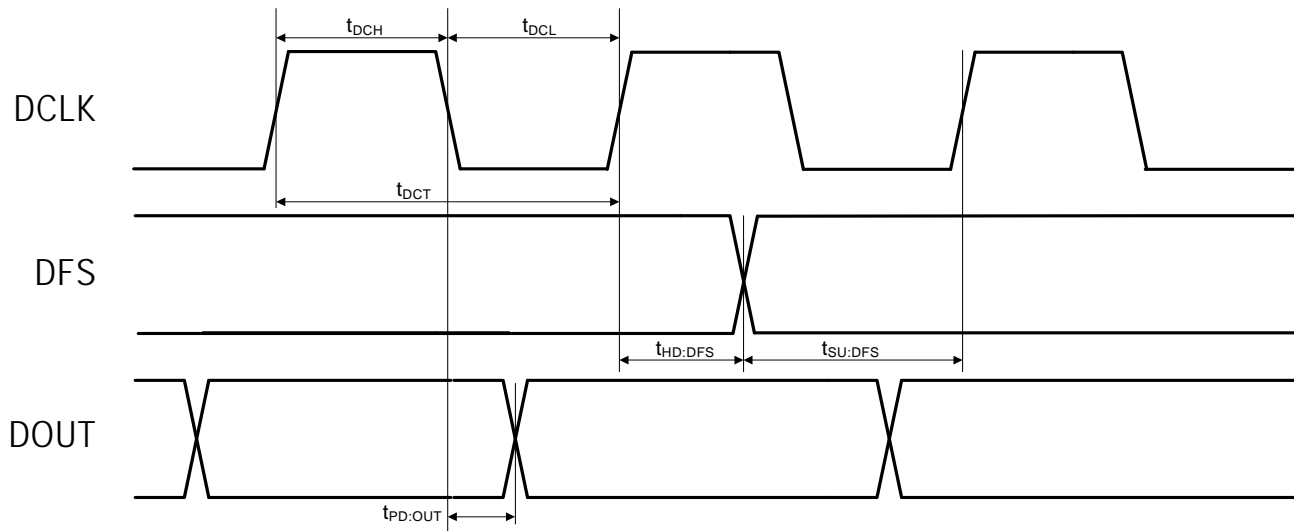

**Figure 6. Digital Audio Interface Timing Parameters, I<sup>2</sup>S Mode**

**Table 8. FM Receiver Characteristics<sup>1,2</sup>**(V<sub>A</sub> = 2.7 to 5.5 V, V<sub>D</sub> = 1.62 to 3.6 V, T<sub>A</sub> = -20 to 85 °C, 76–108 MHz)

Parameter	Symbol	Test Condition	Min	Typ	Max	Unit
Input Frequency	f <sub>RF</sub>		76	—	108	MHz
RDS Sensitivity <sup>3,4</sup>		Δf = 2 kHz, RDS BLER < 5%	—	8	—	μV EMF
RDS Synchronization Persistence <sup>3,4</sup>		Δf = 2 kHz RDSSYNC = 1 ≥ 10 sec	—	3.8/60	—	μV EMF/RDS BLER%
RDS Synchronization Stability <sup>3,4</sup>		Δf = 2 kHz RDSSYNC = 1 ≥ 10 sec	—	5.9/10	—	μV EMF/ RDS BLER%
RDS Synchronization Time <sup>3,4,5</sup>		Δf = 2 kHz	—	40	—	ms
RDS PI Lock Time <sup>3,4,5,6</sup>		Δf = 2 kHz	—	60	—	ms
LNA Input Resistance <sup>3</sup>			3	4	5	kΩ
LNA Input Capacitance <sup>3</sup>			4	5	6	pF
Input IP3 <sup>3</sup>		400 and 800 kHz blockers, AGC disabled	100	105	—	dBμV EMF
Image Rejection <sup>3</sup>			—	40	—	dB
AM Suppression <sup>3</sup>		m = 0.3	40	50	—	dB
Audio Sensitivity <sup>4,6,7</sup>		(S+N)/N = 26 dB	—	2.2	3.5	μV EMF
Audio Sensitivity with 50 Ω Network <sup>3,6,7</sup>		(S+N)/N = 26 dB	—	1.1	—	μV EMF
LPI Sensitivity <sup>3</sup>			—	3.5	—	μV EMF
Adjacent Channel Selectivity		±200 kHz	35	50	—	dB
Alternate Channel Selectivity		±400 kHz	60	70	—	dB
Blocking Sensitivity <sup>3,8,9,10</sup>		Δf = ±400 kHz	—	34	—	dBμV
		Δf = ±4 MHz	—	30	—	dBμV

**Notes:**

1. Additional testing information is available in application note, “AN388: Si470x/1x/2x/3x/4x Evaluation Board Test Procedure.” Volume = maximum for all tests. Tested at RF = 98.5 MHz.
2. To ensure proper operation and receiver performance, follow the guidelines in “AN332: Si47xx Programming Guide”, and “AN383: Si47xx Antenna, Schematic, Layout, and Design Guidelines”. Silicon Laboratories will evaluate schematics and layouts for qualified customers.
3. Guaranteed by characterization.
4. Half-wavelength FM antenna matching network.
5. V<sub>EMF</sub> = 1 mV.
6. Δf = 22.5 kHz.
7. B<sub>AF</sub> = 300 Hz to 15 kHz, A-weighted.
8. F<sub>MOD</sub> = 1 kHz, 75 μs de-emphasis, MONO = enabled, and L = R unless noted otherwise.
9. Blocker Amplitude = 100 dBμV
10. Sensitivity measured at (S+N)/N = 26 dB.
11. Δf = 75 kHz.
12. At temperature 25 °C.

# Si4706-D50

**Table 8. FM Receiver Characteristics<sup>1,2</sup> (Continued)**

( $V_A = 2.7$  to  $5.5$  V,  $V_D = 1.62$  to  $3.6$  V,  $T_A = -20$  to  $85$  °C,  $76$ – $108$  MHz)

Parameter	Symbol	Test Condition	Min	Typ	Max	Unit
Intermod Sensitivity <sup>3,6,7,8,9,10</sup>		$\Delta f_1 = \pm 400$ kHz $\Delta f_2 = \pm 800$ kHz	—	40	—	dB $\mu$ V
		$\Delta f_1 = \pm 4$ MHz $\Delta f_2 = \pm 8$ MHz	—	35	—	$\mu$ V EMF
Spurious Response Rejection <sup>3</sup>		In-band	35	—	—	dB
Audio Output Voltage <sup>6</sup>			72	80	90	mV <sub>RMS</sub>
Audio Output L/R Imbalance		Mono	-1	—	1	dB
Audio Frequency Response Low <sup>3</sup>		-3 dB	—	—	30	Hz
Audio Frequency Response High <sup>3</sup>		-3 dB	15	—	—	kHz
Audio Stereo Separation <sup>5,6</sup>			35	40	—	dB
Audio Mono S/N <sup>5,6,7</sup>			55	63	—	dB
Audio Stereo S/N <sup>5,6,7</sup>			—	58	—	dB
Audio THD <sup>5,11</sup>			—	0.1	0.5	%
De-emphasis Time Constant <sup>3</sup>		FM_DEEMPHASIS = 2	70	75	80	$\mu$ s
		FM_DEEMPHASIS = 1	45	50	54	$\mu$ s
Audio Output Load Resistance <sup>3</sup>	$R_L$	Single-ended, at LOUT/ROUT pins	10	—	—	k $\Omega$
Audio Output Load Capacitance <sup>3</sup>	$C_L$	Single-ended, at LOUT/ROUT pins	—	—	50	pF
Seek/Tune Time <sup>3</sup>		RCLK tolerance = 100 ppm	—	—	60	ms/channel
Powerup Time <sup>3</sup>		From powerdown	—	—	110	ms
RSSI Offset <sup>12</sup>		Input levels of 8 and 60 dB $\mu$ V at RF Input	-3	—	3	dB

**Notes:**

1. Additional testing information is available in application note, “AN388: Si470x/1x/2x/3x/4x Evaluation Board Test Procedure.” Volume = maximum for all tests. Tested at RF = 98.5 MHz.
2. To ensure proper operation and receiver performance, follow the guidelines in “AN332: Si47xx Programming Guide”, and “AN383: Si47xx Antenna, Schematic, Layout, and Design Guidelines”. Silicon Laboratories will evaluate schematics and layouts for qualified customers.
3. Guaranteed by characterization.
4. Half-wavelength FM antenna matching network.
5.  $V_{EMF} = 1$  mV.
6.  $\Delta f = 22.5$  kHz.
7.  $B_{AF} = 300$  Hz to 15 kHz, A-weighted.
8.  $F_{MOD} = 1$  kHz, 75  $\mu$ s de-emphasis, MONO = enabled, and L = R unless noted otherwise.
9. Blocker Amplitude = 100 dB $\mu$ V
10. Sensitivity measured at (S+N)/N = 26 dB.
11.  $\Delta f = 75$  kHz.
12. At temperature 25 °C.

**Table 9. 64–75.9 MHz Input Frequency FM Receiver Characteristics<sup>1,2,3</sup>**(V<sub>A</sub> = 2.7 to 5.5 V, V<sub>D</sub> = 1.62 to 3.6 V, T<sub>A</sub> = –20 to 85 °C)

Parameter	Symbol	Test Condition	Min	Typ	Max	Unit
Input Frequency	f <sub>RF</sub>		64	—	75.9	MHz
Audio Sensitivity <sup>3,4,5</sup>		(S+N)/N = 26 dB	—	4	—	μV EMF
LNA Input Resistance <sup>5</sup>			3	4	5	kΩ
LNA Input Capacitance <sup>5</sup>			4	5	6	pF
Input IP3 <sup>6</sup>			—	105	—	dBμV EMF
AM Suppression <sup>4,5,7</sup>		m = 0.3	40	50	—	dB
Adjacent Channel Selectivity		±200 kHz	—	50	—	dB
Alternate Channel Selectivity		±400 kHz	—	70	—	dB
Audio Output Voltage <sup>4,5,7</sup>			72	80	90	mV <sub>RMS</sub>
Audio Output L/R Imbalance <sup>5,7,8</sup>			—	—	1	dB
Audio Frequency Response Low		–3 dB	—	—	30	Hz
Audio Frequency Response High		–3 dB	15	—	—	kHz
Audio Mono S/N <sup>4,5,7,9,10</sup>			55	63	—	dB
Audio THD <sup>5,7,8</sup>			—	0.1	0.5	%
De-emphasis Time Constant		FM_DEEMPHASIS = 2	70	75	80	μs
		FM_DEEMPHASIS = 1	45	50	54	μs
Audio Output Load Resistance <sup>10</sup>	R <sub>L</sub>	Single-ended	10	—	—	kΩ
Audio Output Load Capacitance <sup>10</sup>	C <sub>L</sub>	Single-ended	—	—	50	pF
Seek/Tune Time		RCLK tolerance = 100 ppm	—	—	60	ms/channel
Powerup Time		From powerdown	—	—	110	ms
RSSI Offset <sup>11</sup>		Input levels of 8 and 60 dBμV EMF	–3	—	3	dB

**Notes:**

1. Additional testing information is available in “AN388: Si470x/1x/2x/3x/4x Evaluation Board Test Procedure.” Volume = maximum for all tests. Tested at RF = 98.5 MHz.
2. To ensure proper operation and receiver performance, follow the guidelines in “AN383: Si47xx Antenna, Schematic, Layout, and Design Guidelines.” Silicon Laboratories will evaluate schematics and layouts for qualified customers.
3. Guaranteed by characterization.
4. Δf = 22.5 kHz.
5. V<sub>EMF</sub> = 1 mV.
6. |f<sub>2</sub> – f<sub>1</sub>| > 2 MHz, f<sub>0</sub> = 2 x f<sub>1</sub> – f<sub>2</sub>. AGC is disabled.
7. F<sub>MOD</sub> = 1 kHz, 75 μs de-emphasis, MONO = enabled, and L = R unless noted otherwise.
8. Δf = 75 kHz.
9. B<sub>AF</sub> = 300 Hz to 15 kHz, A-weighted.
10. At L<sub>OUT</sub> and R<sub>OUT</sub> pins.
11. At temperature (25 °C).

# Si4706-D50

**Table 10. Reference Clock and Crystal Characteristics**

( $V_A = 2.7$  to  $5.5$  V,  $V_D = 1.62$  to  $3.6$  V,  $T_A = -20$  to  $85$  °C)

Parameter	Symbol	Test Condition	Min	Typ	Max	Unit
<b>Reference Clock</b>						
RCLK Supported Frequencies <sup>1,2</sup>			31.130	32.768	40,000	kHz
RCLK Frequency Tolerance <sup>1,3</sup>			-100	—	100	ppm
REFCLK_PRESCALE <sup>1,2</sup>			1	—	4095	
REFCLK <sup>1</sup>			31.130	32.768	34.406	kHz
<b>Crystal Oscillator</b>						
Crystal Oscillator Frequency <sup>1</sup>			—	32.768	—	kHz
Crystal Frequency Tolerance <sup>1,3</sup>			-100	—	100	ppm
Board Capacitance <sup>1</sup>			—	—	3.5	pF
<b>Notes:</b>						
1. Guaranteed by characterization.						
2. The Si4706 divides the RCLK input by REFCLK_PRESCALE to obtain REFCLK. There are some RCLK frequencies between 31.130 kHz and 40 MHz that are not supported. See “AN332: Si47xx Programming Guide,” Table 6 for more details.						
3. A frequency tolerance of $\pm 50$ ppm is required for FM seek/tune using 50 kHz channel spacing.						

## 2. Typical Application Schematic

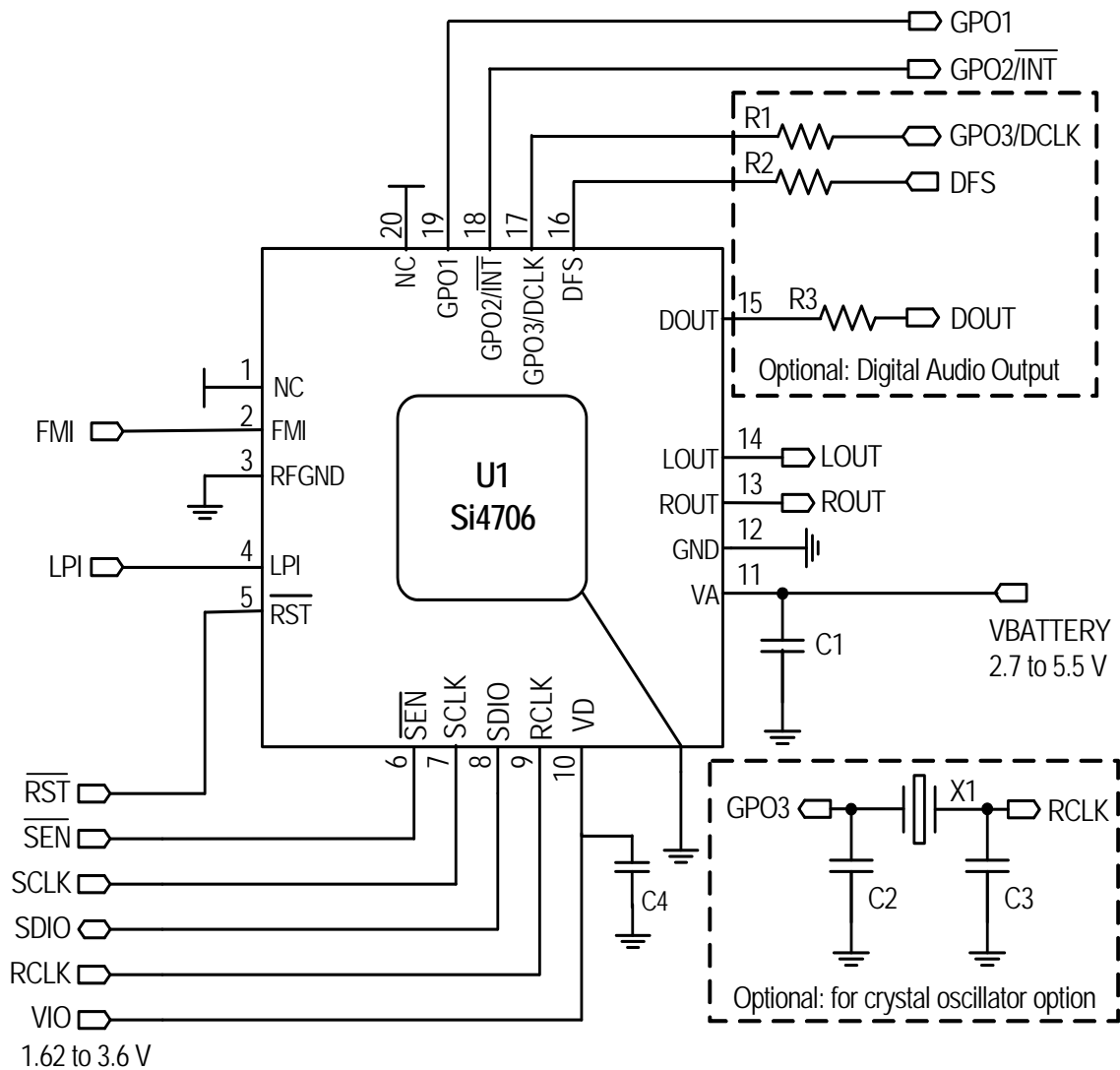

### Notes:

1. Place C1 close to V<sub>A</sub> pin.
2. Pins 1 and 20 are no connects, leave floating.
3. Place C4 close to V<sub>D</sub> pin.
4. To ensure proper operation and receiver performance, follow the guidelines in "AN383: Si47xx Antenna, Schematic, Layout, and Design Guidelines." Silicon Laboratories will evaluate schematics and layouts for qualified customers.
5. Pin 2 or Pin 4 connects to the FM antenna interface. Pin 2 is for a half-wave antenna. Pin 4 is for an embedded antenna.
6. Place Si4706 as close as possible to antenna jack and keep the FMI and LPI traces as short as possible.

# Si4706-D50

---

## 3. Bill of Materials

Component(s)	Value/Description	Supplier
C1	Supply bypass capacitor, 22 nF, $\pm 20\%$ , Z5U/X7R	Murata
C4	Supply bypass capacitor, 100 nF, $\pm 10\%$ , Z5U/X7R	Murata
U1	Si4706 FM Radio Receiver	Silicon Laboratories
<b>Optional Components</b>		
C2, C3	Crystal load capacitors, 22 pF, $\pm 5\%$ , COG (Optional: for crystal oscillator option)	Venkel
X1	32.768 kHz crystal (Optional: for crystal oscillator option)	Epson
R1	Resistor, 2 k $\Omega$ (Optional: for digital audio)	Venkel
R2	Resistor, 2 k $\Omega$ (Optional: for digital audio)	Venkel
R3	Resistor, 600 $\Omega$ (Optional: for digital audio)	Venkel

## 4. Functional Description

### 4.1. Overview

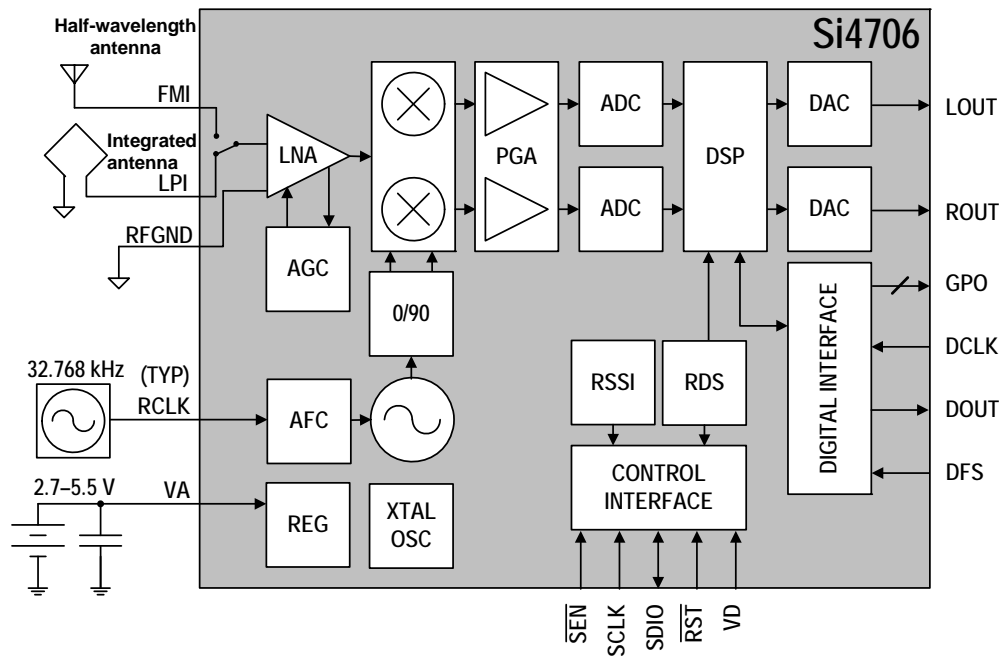

**Figure 7. Functional Block Diagram**

The Si4706-D50 offers advanced audio processing plus advanced RDS processing in a very small, 100% CMOS receiver integrated circuit. The device provides both analog and digital audio out, and a highly flexible RDS pre-processor and 100 block RDS buffer. It is an ideal product for handsets and portable devices seeking to optimize both sound and data receiver performance. For sound, the advanced audio processing is unprecedented in portable devices. For RDS data applications such as song-tagging, meta-data, traffic message channel, or other open data applications, the advanced and patented R(B)DS decoding engine offers outstanding data synchronization and integrity. The RDS engine includes demodulation, symbol decoding, advanced error correction, detailed visibility to block-error rates (BLER), advanced decoder reliability, and synchronization status. The Si4706 provides complete, decoded and error-corrected RDS groups (100 blocks), up to 25 groups at a time. The Si4706 offers several modes of operation for various applications which require more or less visibility to the RDS status and group data.

**\*Note:** The term “RDS” will be used to mean “RDS/RBDS” throughout the document.

The Si4706 receiver draws on Silicon Laboratories’ broadcast audio expertise and patent portfolio, using a digital low intermediate frequency (low-IF) receiver architecture proven by hundreds of millions of Silicon Laboratories’ broadcast audio receivers shipped worldwide.

Silicon Labs has shipped 1/2 billion broadcast audio receivers worldwide using this architecture. The low-IF architecture allows the Si4706 to deliver superior performance while integrating the great majority of external components required by competing solutions. The Si4706 digital integration reduces the required external components of traditional offerings, resulting in a solution requiring only an external bypass capacitor and occupying board space of approximately 15 mm<sup>2</sup>.

The Si4706 is the first FM radio receiver IC to support embedded antenna technology, allowing the FM antenna to be integrated into the enclosure or PCB of a portable device. For portable navigation devices, the Si4706 embedded antenna feature permits integration of the FM antenna into the enclosure of the device and eliminates the need for external antenna cables. Refer to “AN383: Si47xx Antenna, Schematic, Layout, And Design Guidelines” for antenna design guidelines.

The Si4706 is feature-rich, providing highly automated performance with default settings and extensive programmability and flexibility for customized system performance.

The Si4706 performs much of the FM demodulation digitally to achieve high fidelity, optimal performance versus power consumption, and flexibility of design. The on-board DSP provides unmatched pilot rejection, selectivity, and optimum sound quality. The integrated micro-controller offers both the manufacturer and the end-user unmatched programmability and flexibility in the listening experience.

## 4.2. FM Receiver

The Si4706 FM receiver is based on the proven Si4700/01/02/03 FM radio receiver. The part leverages Silicon Laboratories' proven and patented FM broadcast radio receiver digital architecture, delivering excellent RF performance and interference rejection. The proven digital techniques provide good sensitivity in weak signal environments while allowing superb selectivity and inter-modulation immunity in strong signal environments.

The part supports the worldwide FM broadcast band (64 to 108 MHz) with channel spacings of 50–200 kHz. The low-IF architecture utilizes a single converter stage and digitizes the signal using a high-resolution analog-to-digital converter. The audio output can be directed either to an external headphone amplifier via analog in/out or to other system ICs through digital audio interface (I<sup>2</sup>S).

## 4.3. Stereo Audio Processing

The output of the FM demodulator is a stereo multiplexed (MPX) signal. The MPX standard was developed in 1961, and is used worldwide. Today's MPX signal format consists of left + right (L+R) audio, left – right (L–R) audio, a 19 kHz pilot tone, and RDS/RBDS data as shown in Figure 8.

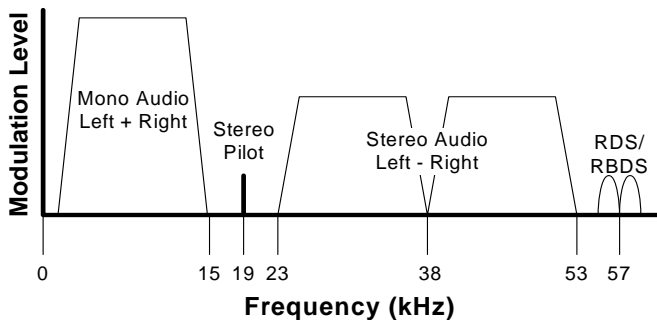

Figure 8. MPX Signal Spectrum

### 4.3.1. Stereo Decoder

The Si4706 integrated stereo decoder automatically decodes the MPX signal using DSP techniques. The 0–15 kHz (L+R) signal is the mono output of the FM tuner. Stereo is generated from the (L+R), (L–R), and a 19 kHz pilot tone. The pilot tone is used as a reference to recover the (L–R) signal. Output left and right channels are obtained by adding and subtracting the (L+R) and (L–R) signals, respectively.

### 4.3.2. Stereo-Mono Blending

Adaptive noise suppression is employed to gradually combine the stereo left and right audio channels to a mono (L+R) audio signal as the signal quality degrades to maintain optimum sound fidelity under varying reception conditions. Three metrics, received signal strength indicator (RSSI), signal-to-noise ratio (SNR), and multipath interference, are monitored simultaneously in forcing a blend from stereo to mono. The metric which reflects the minimum signal quality takes precedence and the signal is blended appropriately.

All three metrics have programmable stereo/mono thresholds and attack/release rates detailed in “AN322: Si47xx Programming Guide.” If a metric falls below its mono threshold, the signal is blended from stereo to full mono. If all metrics are above their respective stereo thresholds, then no action is taken to blend the signal. If a metric falls between its mono and stereo thresholds, then the signal is blended to the level proportional to the metric's value between its mono and stereo thresholds, with an associated attack and release rate. Stereo/mono status can be monitored with the FM\_RSQ\_STATUS command.

## 4.4. Received Signal Qualifiers

The quality of a tuned signal can vary depending on many factors including environmental conditions, time of day, and position of the antenna. To adequately manage the audio output and avoid unpleasant audible effects to the end-user, the Si4706-D50 monitors and provides indicators of the signal quality, allowing the host processor to perform additional processing if required by the customer. The Si4706-D50 monitors signal quality metrics including RSSI, SNR, and multipath interference on FM signals. These metrics are used to optimize signal processing and are also reported to the host processor. The signal processing algorithms can use either Silicon Labs' optimized settings (recommended) or be customized to modify performance.

## 4.5. De-emphasis

Pre-emphasis and de-emphasis is a technique used by FM broadcasters to improve the signal-to-noise ratio of FM receivers by reducing the effects of high-frequency interference and noise. When the FM signal is transmitted, a pre-emphasis filter is applied to accentuate the high audio frequencies. The Si4706 incorporates a de-emphasis filter that attenuates high frequencies to restore a flat frequency response. Two time constants are used in various regions. The de-emphasis time constant is programmable to 50 or 75  $\mu$ s and is set by the FM\_DEEMPHASIS property.

## 4.6. Stereo DAC

High-fidelity stereo digital-to-analog converters (DACs) drive analog audio signals onto the LOUT and ROUT pins. The audio output may be muted. Volume is adjusted digitally with the RX\_VOLUME property.

## 4.7. Soft Mute

The soft mute feature is available to attenuate the audio outputs and minimize audible noise in very weak signal conditions. The soft mute feature is triggered by the SNR metric. The SNR threshold for activating soft mute is programmable, as are soft mute attenuation levels and attack and decay rates.

## 4.8. FM Hi-Cut Control

Hi-cut control is employed on audio outputs with degradation of the signal due to low SNR and/or multipath interference. Two metrics, SNR and multipath interference, are monitored concurrently in forcing hi-cut of the audio outputs. Programmable minimum and maximum thresholds are available for both metrics. The transition frequency for hi-cut is also programmable with up to seven hi-cut filter settings. A single set of attack and release rates for hi-cut are programmable for both metrics from a range of 2 ms to 64 s. The level of hi-cut applied can be monitored with the FM\_RSQ\_STATUS command. Hi-cut can be disabled by setting the hi-cut filter to the default audio bandwidth of 15 kHz.

## 4.9. Tuning

The frequency synthesizer uses Silicon Laboratories' proven technology, including a completely integrated VCO. The frequency synthesizer generates the quadrature local oscillator signal used to downconvert the RF input to a low intermediate frequency. The VCO frequency is locked to the reference clock and adjusted with an automatic frequency control (AFC) servo loop during reception. The tuning frequency can be directly programmed using the FM\_TUNE\_FREQ. The Si4706 supports channel spacing of 50, 100, or 200 kHz in FM mode.

## 4.10. Seek

The Si4706 seek functionality is performed completely on-chip and will search up or down the selected frequency band for a valid channel. A valid channel is qualified according to a series of programmable signal indicators and thresholds. The seek function can be made to stop at the band edge and provide an interrupt, or wrap the band and continue seeking until arriving at the original departure frequency. The device sets interrupts with found valid stations or, if the seek results in zero found valid stations, the device indicates failure and again sets an interrupt. Refer to "AN332: Si47xx Programming Guide."

The Si4706-D50 uses RSSI, SNR, and AFC to qualify stations. Most of these variables have programmable thresholds for modifying the seek function according to customer needs.

RSSI is employed first to screen all possible candidate stations. SNR and AFC are subsequently used in screening the RSSI qualified stations. The more thresholds the system engages, the higher the confidence that any found stations will indeed be valid broadcast stations; however, the more challenging levels the thresholds are set to, the longer the overall seek time as more stations and more qualifiers will be assessed. The Si4706-D50 defaults set RSSI to a mid-level threshold and add an SNR threshold set to a level delivering acceptable audio performance. This trade-off will eliminate very low RSSI stations while keeping the seek time to acceptable levels. Generally, the time to auto-scan and store valid channels for an entire FM band with all thresholds engaged is very short depending on the band content.

Seek is initiated using the FM\_SEEK\_START command. The RSSI and SNR threshold settings are adjustable using properties.

## 4.11. Digital Audio Interface

The digital audio interface operates in slave mode and supports a variety of MSB-first audio data formats including I<sup>2</sup>S and left-justified modes. The interface has three pins: digital data input (DIN), digital frame synchronization input (DFS), and a digital bit synchronization input clock (DCLK). The Si4706 supports a number of industry-standard sampling rates including 32, 40, 44.1, and 48 kHz. The digital audio interface enables low-power operation by eliminating the need for redundant DACs and ADCs on the audio baseband processor.

### 4.11.1. Audio Data Formats

The digital audio interface operates in slave mode and supports three different audio data formats:

- I<sup>2</sup>S
- Left-Justified
- DSP Mode

In I<sup>2</sup>S mode, by default the MSB is captured on the second rising edge of DCLK following each DFS transition. The remaining bits of the word are sent in order, down to the LSB. The left channel is transferred first when the DFS is low, and the right channel is transferred when the DFS is high.

In left-justified mode, by default the MSB is captured on the first rising edge of DCLK following each DFS transition. The remaining bits of the word are sent in order, down to the LSB. The left channel is transferred first when the DFS is high, and the right channel is transferred when the DFS is low.

In DSP mode, the DFS becomes a pulse with a width of 1DCLK period. The left channel is transferred first, followed right away by the right channel. There are two options in transferring the digital audio data in DSP mode: the MSB of the left channel can be transferred on the first rising edge of DCLK following the DFS pulse or on the second rising edge.

In all audio formats, depending on the word size, DCLK frequency, and sample rates, there may be unused DCLK cycles after the LSB of each word before the next DFS transition and MSB of the next word. In addition, if preferred, the user can configure the MSB to be captured on the falling edge of DCLK via properties. The number of audio bits can be configured for 8, 16, 20, or 24 bits.

### 4.11.2. Audio Sample Rates

The device supports a number of industry-standard sampling rates including 32, 40, 44.1, and 48 kHz. The digital audio interface enables low-power operation by eliminating the need for redundant DACs on the audio baseband processor.

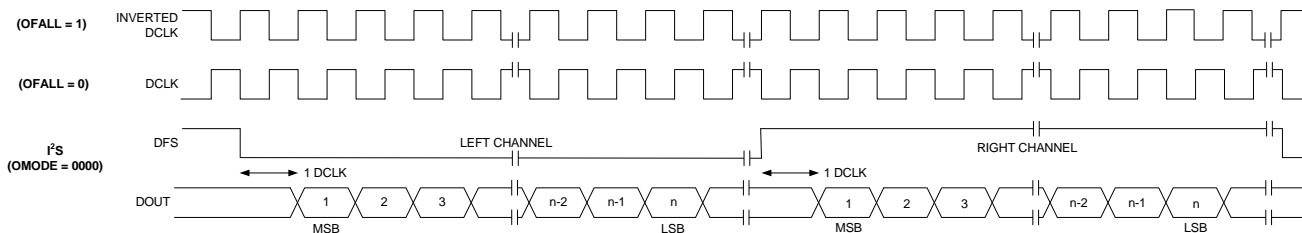

Figure 9. I<sup>2</sup>S Digital Audio Format

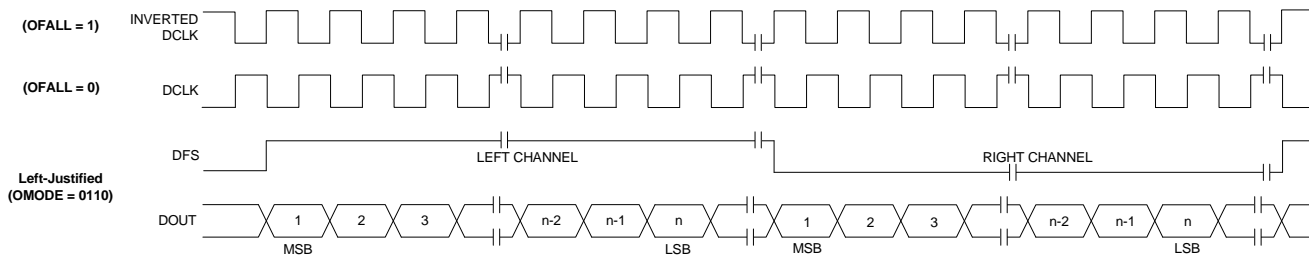

Figure 10. Left-Justified Digital Audio Format

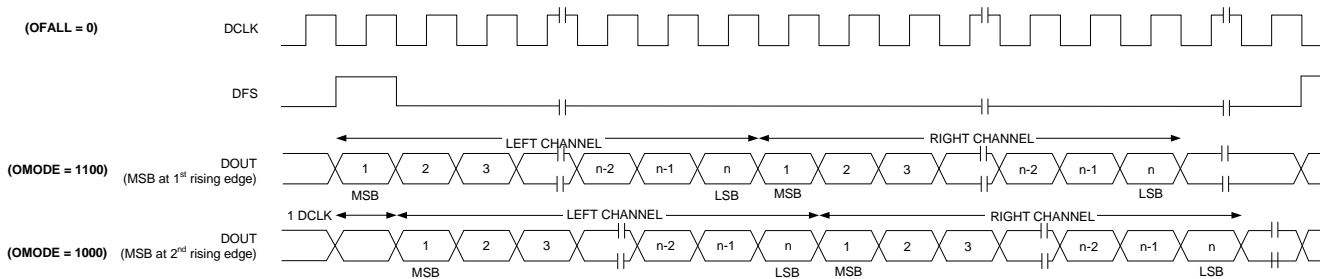

Figure 11. DSP Digital Audio Format

## 4.12. Embedded Antenna Support

The Si4706 is the first FM receiver to support the fast growing trend to integrate the FM receiver antenna into the device enclosure. The chip is designed with this function in mind from the outset, with multiple international patents pending, thus it is superior to many other options in price, board space, and performance.

Testing indicates that, when using Silicon Laboratories' patented techniques, embedded antenna performance can be very similar in many key metrics to a standard half-wavelength antenna. Refer to "AN383: Si47xx

Antenna, Schematic, Layout, And Design Guidelines" for additional details on the implementation of support for an embedded antenna.

Figure 12 shows a conceptual block diagram of the Si4706 architecture used to support the embedded antenna. The half-wavelength FM receive antenna is therefore optional. Host software can detect the presence of an external antenna and switch between the embedded antenna if desired.

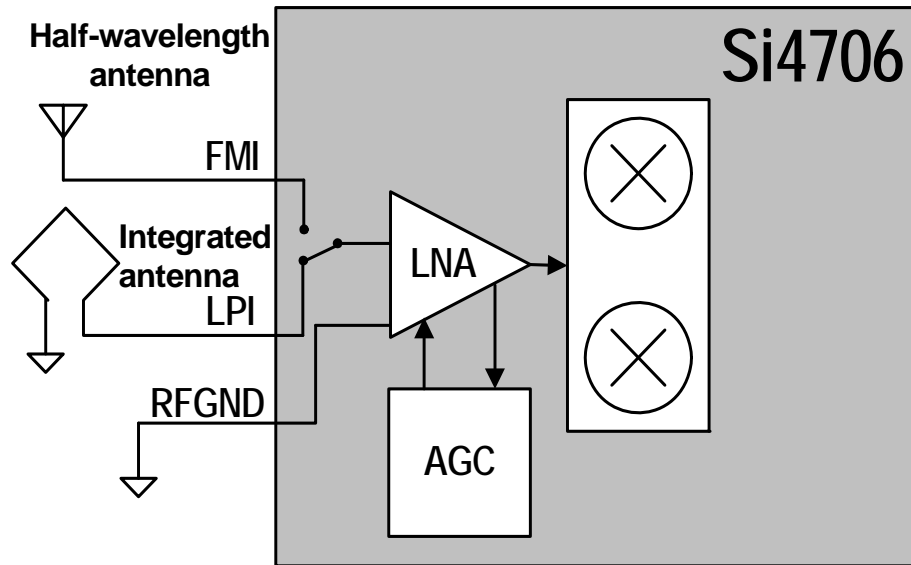

Figure 12. Conceptual Block Diagram of the Si4706 Embedded Antenna Support

### 4.13. RDS Decoder

The Si4706 implements an advanced, patented, high-performance RDS processor for demodulation, symbol decoding, block synchronization, error detection, and error correction. The RDS decoder provides several significant benefits over traditional implementations, including very fast and robust RDS synchronization in noisy signal levels with very high block error rates (BLER), industry-leading sensitivity, and improved data reliability in all signal environments.

Figure 13 illustrates the benefit of robust synchronization. The Si4706's strong synchronization performance at noisy signal levels minimizes or even eliminates re-synchronization time required as the signal carrier-to-noise ratio (CNR) fluctuates. The Si4706 decoder is continuously synchronized to the RDS block/group despite loss of data due to data block errors. This translates to lower loss of data compared to competing solutions.

Figure 14 illustrates the Si4706 RDS decoder performance. With the aid of robust synchronization, the decoder additionally provides for operation at lower sensitivity levels for a given BLER compared to competing solutions, and delivers reception in environments where signal power is very low or compromised. The decoder failure probability drops

significantly when compared to competing solutions.

The Si4706 also provides unmatched flexibility in programming the interaction between the host processor and the device. The Si4706 can be configured to provide varying levels of visibility from very high visibility to each RDS block with corresponding BLER, to a lower level of granularity providing complete RDS groups with BLER by block. Additionally, the Si4706 can provide interrupts on changes to RDS block A and/or B. The Si4706 device provides a configurable interrupt when RDS is synchronized and RDS group data has been received. The device provides configurable interrupts for up to 100 blocks with detailed BLER (25 groups), providing flexibility in interrupt configuration to the host controller. The Si4706 reports RDS decoder synchronization status and detailed bit errors for each RDS block with the FM\_RDS\_STATUS command. The range of reportable bit errors that are detected and corrected are 0, 1-2, 3-5, and "not correctable." More than five bit errors indicates that the corresponding block information word is not correctable.

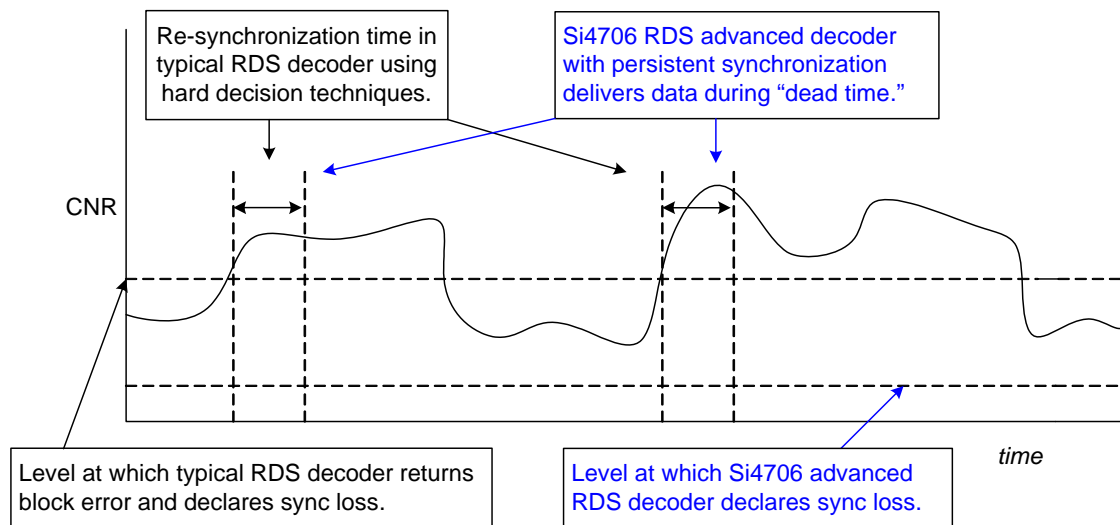

**Figure 13. Illustrative Si4706 Advanced RDS Synchronization**

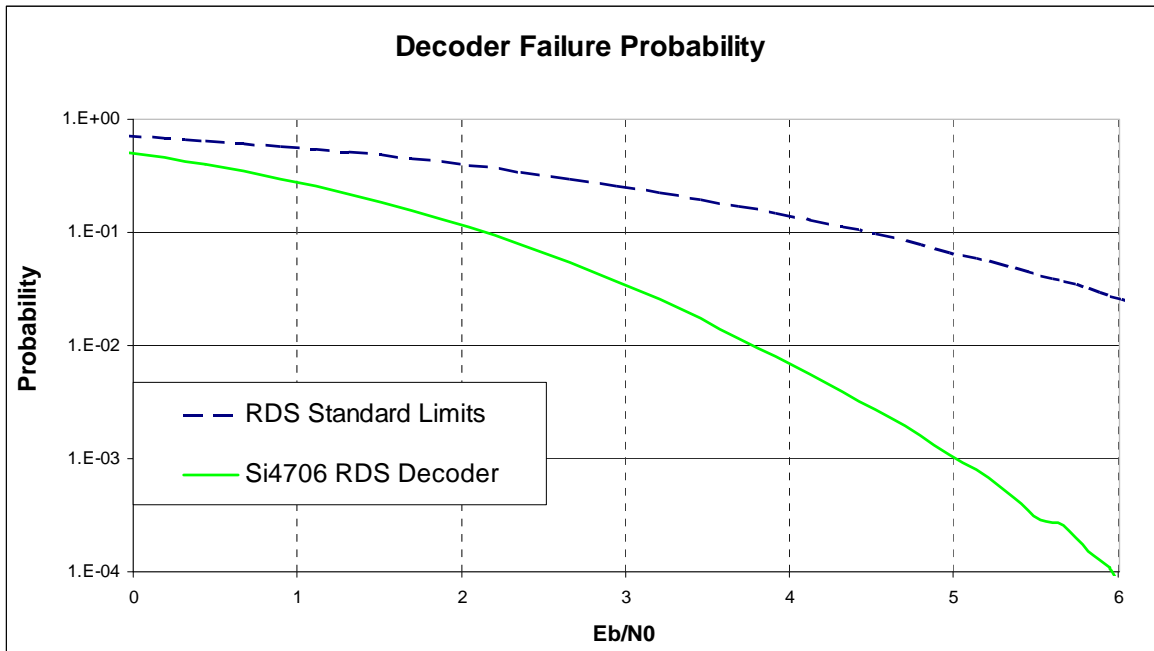

Figure 14. Si4706 Preliminary Decoder Performance

#### 4.14. Reference Clock

The Si4706 reference clock is programmable, supporting RCLK frequencies in Table 10. Refer to Table 3, “DC Characteristics” on page 5 for switching voltage levels and Table 10, “Reference Clock and Crystal Characteristics” on page 14 for frequency tolerance information.

An onboard crystal oscillator is available to generate the 32.768 kHz reference when an external crystal and load capacitors are provided. Refer to “2. Typical Application Schematic” on page 15. This mode is enabled using the POWER\_UP command. Refer to Refer to “AN332: Si47xx Programming Guide”.

The Si4706 performance may be affected by data activity on the SDIO bus when using the integrated internal oscillator. SDIO activity results from polling the tuner for status or communicating with other devices that share the SDIO bus. If there is SDIO bus activity while the Si4706 is performing the seek/tune function, the crystal oscillator may experience jitter, which may result in mistunes, false stops, and/or lower SNR.

For best seek/tune results, Silicon Laboratories recommends that all SDIO data traffic be suspended during Si4706 seek and tune operations. This is achieved by keeping the bus quiet for all other devices on the bus, and delaying tuner polling until the tune or seek operation is complete. The seek/tune complete (STC) interrupt should be used instead of polling to determine when a seek/tune operation is complete.

## 4.15. Control Interface

A serial port slave interface is provided, which allows an external controller to send commands to the Si4706 and receive responses from the device. The serial port can operate in two bus modes: 2-wire mode and 3-wire mode. The Si4706 selects the bus mode by sampling the state of the GPO1 and GPO2 pins on the rising edge of  $\overline{\text{RST}}$ . The GPO1 pin includes an internal pull-up resistor, which is connected while  $\overline{\text{RST}}$  is low, and the GPO2 pin includes an internal pull-down resistor, which is connected while  $\overline{\text{RST}}$  is low. Therefore, it is only necessary for the user to actively drive pins which differ from these states. See Table 11.

**Table 11. Bus Mode Select on Rising Edge of  $\overline{\text{RST}}$**

Bus Mode	GPO1	GPO2
2-Wire	1	0
3-Wire	0 (must drive)	0

After the rising edge of  $\overline{\text{RST}}$ , the pins GPO1 and GPO2 are used as general purpose output (O) pins as described in Section “4.16. GPO Outputs”. In any bus mode, commands may only be sent after  $V_{\text{IO}}$  and  $V_{\text{DD}}$  supplies are applied.

In any bus mode, before sending a command or reading a response, the user must first read the status byte to ensure that the device is ready (CTS bit is high).

### 4.15.1. 2-Wire Control Interface Mode

When selecting 2-wire mode, the user must ensure that SCLK is high during the rising edge of  $\overline{\text{RST}}$ , and stays high until after the first start condition. Also, a start condition must not occur within 300 ns before the rising edge of  $\overline{\text{RST}}$ .

The 2-wire bus mode uses only the SCLK and SDIO pins for signaling. A transaction begins with the START condition, which occurs when SDIO falls while SCLK is high. Next, the user drives an 8-bit control word serially on SDIO, which is captured by the device on rising edges of SCLK. The control word consists of a 7-bit device address, followed by a read/write bit (read = 1, write = 0). The Si4706 acknowledges the control word by driving SDIO low on the next falling edge of SCLK.

Although the Si4706 will respond to only a single device address, this address can be changed with the SEN pin (note that the SEN pin is not used for signaling in 2-wire mode). When SEN = 0, the 7-bit device address is 0010001b. When SEN = 1, the address is 1100011b.

For write operations, the user then sends an 8-bit data byte on SDIO, which is captured by the device on rising edges of SCLK. The Si4706 acknowledges each data byte by driving SDIO low for one cycle, on the next falling edge of SCLK. The user may write up to 8 data bytes in a single 2-wire transaction. The first byte is a command, and the next seven bytes are arguments.

For read operations, after the Si4706 has acknowledged the control byte, it will drive an 8-bit data byte on SDIO, changing the state of SDIO on the falling edge of SCLK. The user acknowledges each data byte by driving SDIO low for one cycle, on the next falling edge of SCLK. If a data byte is not acknowledged, the transaction will end. The user may read up to 16 data bytes in a single 2-wire transaction. These bytes contain the response data from the Si4706.

A 2-wire transaction ends with the STOP condition, which occurs when SDIO rises while SCLK is high. For details on timing specifications and diagrams, refer to Table 5, “2-Wire Control Interface Characteristics” on page 7; Figure 2, “2-Wire Control Interface Read and Write Timing Parameters,” on page 8, and Figure 3, “2-Wire Control Interface Read and Write Timing Diagram,” on page 8.

## 4.15.2. 3-Wire Control Interface Mode

When selecting 3-wire mode, the user must ensure that a rising edge of SCLK does not occur within 300 ns before the rising edge of  $\overline{\text{RST}}$ .

The 3-wire bus mode uses the SCLK, SDIO, and  $\overline{\text{SEN}}$  pins. A transaction begins when the user drives  $\overline{\text{SEN}}$  low. Next, the user drives a 9-bit control word on SDIO, which is captured by the device on rising edges of SCLK. The control word consists of a 3-bit device address (A7:A5 = 101b), a read/write bit (read = 1, write = 0), and a 5-bit register address (A4:A0).

For write operations, the control word is followed by a 16-bit data word, which is captured by the device on rising edges of SCLK.

For read operations, the control word is followed by a delay of one-half SCLK cycle for bus turn-around. Next, the Si4706 will drive the 16-bit read data word serially on SDIO, changing the state of SDIO on each rising edge of SCLK.

A transaction ends when the user sets  $\overline{\text{SEN}}$  high, then pulses SCLK high and low one final time. SCLK may either stop or continue to toggle while  $\overline{\text{SEN}}$  is high.

In 3-wire mode, commands are sent by first writing each argument to register(s) 0xA1–0xA3, then writing the command word to register 0xA0. A response is retrieved by reading registers 0xA8–0xAF.

For details on timing specifications and diagrams, refer to Table 6, “3-Wire Control Interface Characteristics” on page 9; Figure 4, “3-Wire Control Interface Write Timing Parameters,” on page 9, and Figure 5, “3-Wire Control Interface Read Timing Parameters,” on page 9.

## 4.16. GPO Outputs

The Si4706 provides three general-purpose output pins. The GPO pins can be configured to output a constant low, constant high, or high-Z. The GPO pins are multiplexed with the bus mode pins or DCLK, depending on the application schematic of the device. GPO2/ $\overline{\text{INT}}$  can be configured to provide interrupts for seek and tune complete, receive signal quality, and RDS.

## 4.17. Reset, Powerup, and Powerdown

Setting the RST pin low will disable analog and digital circuitry, reset the registers to their default settings, and disable the bus. Setting the RST pin high will bring the device out of reset. A powerdown mode is available to reduce power consumption when the part is idle. Putting the device in powerdown mode will disable analog and digital circuitry while keeping the bus active.

## 4.18. Programming with Commands

To ease development time and offer maximum customization, the Si4706 provides a simple yet powerful software interface to program the receiver. The device is programmed using commands, arguments, properties, and responses. To perform an action, the user writes a command byte and associated arguments, causing the chip to execute the given command. Commands control an action such as powerup the device, shut down the device, or tune to a station. Arguments are specific to a given command and are used to modify the command. A complete list of commands is available in “AN332: Si47xx Programming Guide”.

Properties are a special command argument used to modify the default chip operation and are generally configured immediately after powerup. Examples of properties are de-emphasis level, RSSI seek threshold, and soft mute attenuation threshold. Responses provide the user information and are echoed after a command and associated arguments are issued. All commands provide a one-byte status update indicating interrupt and clear-to-send status information. For a detailed description of the commands and properties for the Si4706, see “AN332: Si47xx Programming Guide”.

## 5. Commands and Properties

Refer to “AN332: Si47xx Programming Guide”.

# Si4706-D50

## 6. Pin Descriptions: Si4706-GM

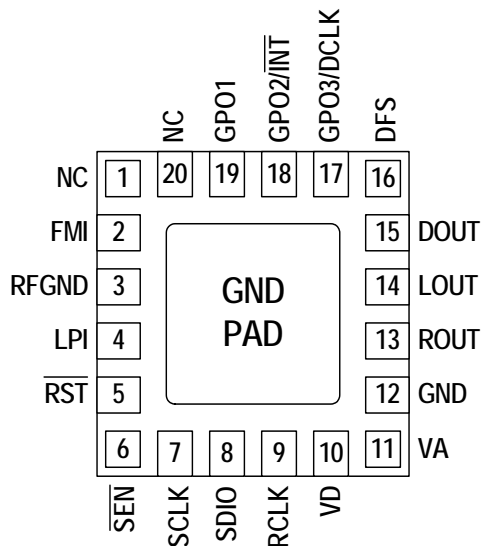

Pin Number(s)	Name	Description
1, 20	NC	No connect. Leave floating.
2	FMI	FM RF input.
3	RFGND	RF ground. Connect to ground plane on PCB.
4	LPI	Loop antenna RF input.
5	$\overline{\text{RST}}$	Device reset input (active low).
6	$\overline{\text{SEN}}$	Serial enable input (active low).
7	SCLK	Serial clock input.
8	SDIO	Serial data input/output.
9	RCLK	External reference or crystal oscillator input.
10	$V_D$	Digital and I/O supply voltage.
11	$V_A$	Analog supply voltage. May be connected directly to battery.
13	ROUT	Right audio analog line output.
14	LOUT	Left audio analog line output.
15	DOUT	Digital audio output data.
16	DFS	Digital frame synchronization.
17	GPO3/DCLK	General purpose output/digital bit synchronous clock or crystal oscillator input.
18	$\overline{\text{GPO2/INT}}$	General purpose output/interrupt.
19	GPO1	General purpose output.
12, GND PAD	GND	Ground. Connect to ground plane on PCB.

## 7. Ordering Guide

Part Number*	Description	Package Type	Operating Temperature
Si4706-D50-GM	FM RDS Broadcast Radio Receiver	QFN Pb-free	-20 to 85 °C

\***Note:** Add an "(R)" at the end of the device part number to denote tape and reel option.

# Si4706-D50

---

## 8. Package Markings

### 8.1. Si4706 Top Mark

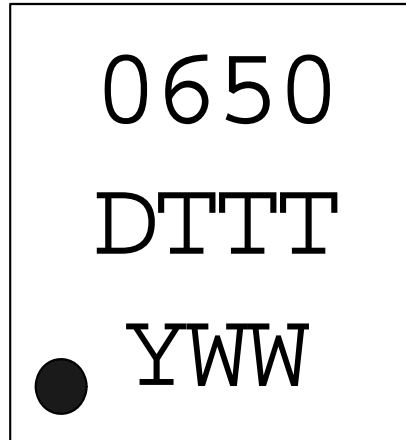

Figure 15. Si4706 Top Mark

### 8.2. Top Mark Explanation

<b>Mark Method:</b>	YAG Laser	
<b>Line 1 Marking:</b>	Part Number	06 = Si4706
	Firmware Revision	50 = Firmware Revision 50
<b>Line 2 Marking:</b>	R = Die Revision	D = Revision D Die
	TTT = Internal Code	Internal tracking code
<b>Line 3 Marking:</b>	Circle = 0.5 mm Diameter (Bottom-Left Justified)	Pin 1 Identifier
	Y = Year WW = Workweek	Assigned by the Assembly House. Corresponds to the last significant digit of the year and workweek of the mold date.

## 9. Package Outline: Si4706 QFN

Figure 16 illustrates the package details for the Si4706. Table 12 lists the values for the dimensions shown in the illustration.

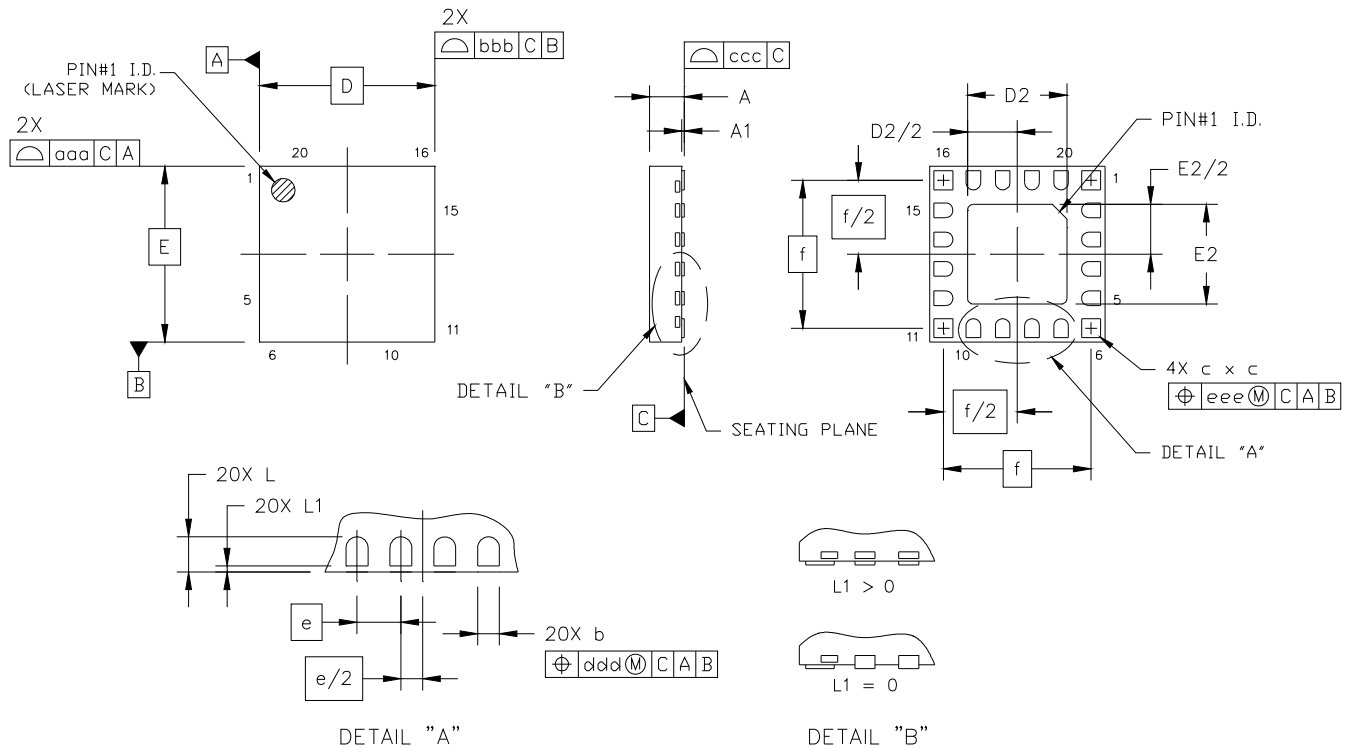

Figure 16. 20-Pin Quad Flat No-Lead (QFN)

Table 12. Package Dimensions

Symbol	Millimeters		
	Min	Nom	Max
A	0.50	0.55	0.60
A1	0.00	0.02	0.05
b	0.18	0.25	0.30
c	0.27	0.32	0.37
D	3.00 BSC		
D2	1.60	1.70	1.80
e	0.50 BSC		
E	3.00 BSC		
E2	1.60	1.70	1.80

Symbol	Millimeters		
	Min	Nom	Max
f	2.53 BSC		
L	0.35	0.40	0.45
L1	0.00	—	0.10
aaa	—	—	0.05
bbb	—	—	0.05
ccc	—	—	0.08
ddd	—	—	0.10
eee	—	—	0.10

**Notes:**

- All dimensions are shown in millimeters unless otherwise noted.
- Dimensioning and tolerancing per ANSI Y14.5M-1994.

## 10. PCB Land Pattern: Si4706 QFN

Figure 17 illustrates the PCB land pattern details for the Si4706-GM. Table 13 lists the values for the dimensions shown in the illustration.

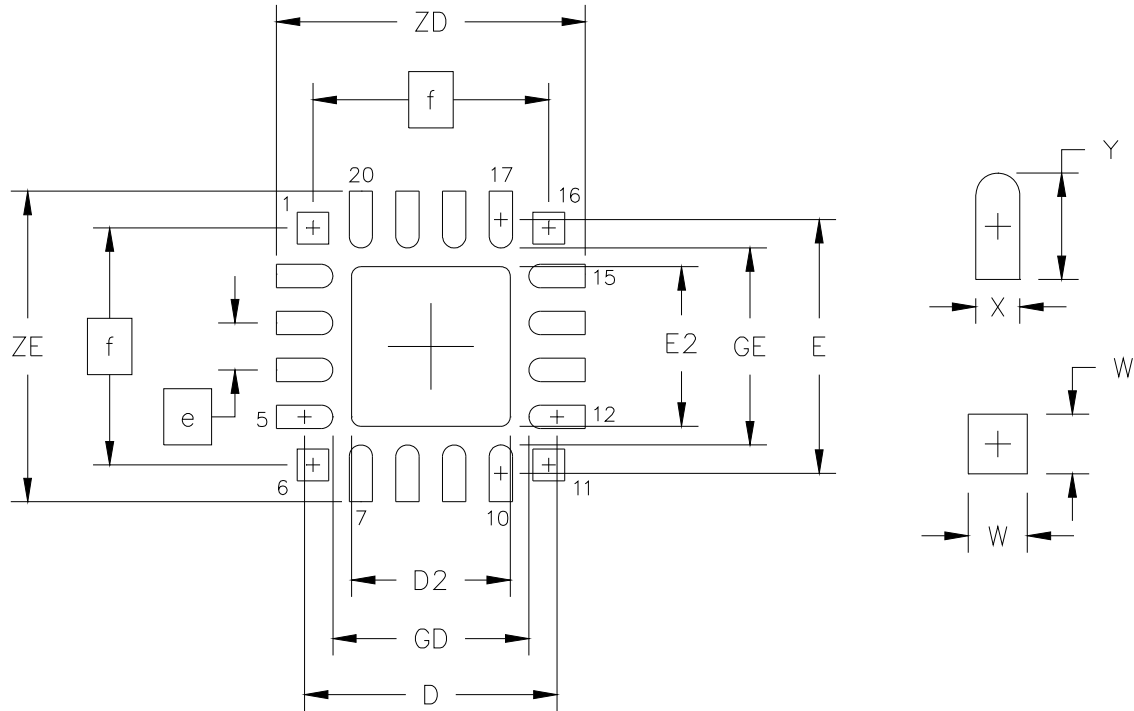

Figure 17. PCB Land Pattern

Table 13. PCB Land Pattern Dimensions

Symbol	Millimeters		Symbol	Millimeters	
	Min	Max		Min	Max
D	2.71 REF		GE	2.10	—
D2	1.60	1.80	W	—	0.34
e	0.50 BSC		X	—	0.28
E	2.71 REF		Y	0.61 REF	
E2	1.60	1.80	ZE	—	3.31
f	2.53 BSC		ZD	—	3.31
GD	2.10	—			

**Notes: General**

1. All dimensions shown are in millimeters (mm) unless otherwise noted.
2. Dimensioning and tolerancing is per the ANSI Y14.5M-1994 specification.
3. This land pattern design is based on IPC-SM-782 guidelines.
4. All dimensions shown are at maximum material condition (MMC). Least material condition (LMC) is calculated based on a fabrication allowance of 0.05 mm.

**Notes: Solder Mask Design**

1. All metal pads are to be non-solder mask defined (NSMD). Clearance between the solder mask and the metal pad is to be 60  $\mu$ m minimum, all the way around the pad.

**Notes: Stencil Design**

1. A stainless steel, laser-cut and electro-polished stencil with trapezoidal walls should be used to assure good solder paste release.
2. The stencil thickness should be 0.125 mm (5 mils).
3. The ratio of stencil aperture to land pad size should be 1:1 for the perimeter pads.
4. A 1.45 x 1.45 mm square aperture should be used for the center pad. This provides approximately 70% solder paste coverage on the pad, which is optimum to assure correct component stand-off.

**Notes: Card Assembly**

1. A No-Clean, Type-3 solder paste is recommended.
2. The recommended card reflow profile is per the JEDEC/IPC J-STD-020 specification for small body components.

## 11. Additional Reference Resources

- Customer Support Site:  
This site contains all application notes, evaluation board schematics and layouts, and evaluation software. NDA is required for complete access. Please visit the Silicon Labs Technical Support web page: <https://www.silabs.com/support/pages/contacttechnicalsupport.aspx> and register to submit a technical support request.
- AN332: Si47xx Programming Guide
- AN342: Quick Start Guide
- AN383: Si47xx Antenna, Schematic, Layout and Design Guidelines
- AN388: Si470x/1x/2x/3x/4x Evaluation Board Test Procedure
- Si47xx EVB User's Guide
- Si4706-D50ER063010 Errata

## DOCUMENT CHANGE LIST

### Revision 0.1 to Revision 0.2

- Added line in Table 3 for VD supply current in Analog Output Mode
- Split Table 8 into Table 8 covering 76–108 MHz, and Table 9 covering 64–75.9 MHz
- Corrected Top Mark to show D revision instead of C revision in sections 8.1 and 8.2

### Revision 0.2 to Revision 1.0

- Added maximum current consumption specs to Table 3
- Added LPI sensitivity spec to Table 8
- Added Intermod sensitivity spec to Table 8
- Added sensitivity specs to Table 8
- Updated typical blocking sensitivity specs in Table 8



Smart.  
Connected.  
Energy-Friendly



**Products**  
[www.silabs.com/products](http://www.silabs.com/products)



**Quality**  
[www.silabs.com/quality](http://www.silabs.com/quality)



**Support and Community**  
[community.silabs.com](http://community.silabs.com)

#### Disclaimer

Silicon Laboratories intends to provide customers with the latest, accurate, and in-depth documentation of all peripherals and modules available for system and software implementers using or intending to use the Silicon Laboratories products. Characterization data, available modules and peripherals, memory sizes and memory addresses refer to each specific device, and "Typical" parameters provided can and do vary in different applications. Application examples described herein are for illustrative purposes only. Silicon Laboratories reserves the right to make changes without further notice and limitation to product information, specifications, and descriptions herein, and does not give warranties as to the accuracy or completeness of the included information. Silicon Laboratories shall have no liability for the consequences of use of the information supplied herein. This document does not imply or express copyright licenses granted hereunder to design or fabricate any integrated circuits. The products must not be used within any Life Support System without the specific written consent of Silicon Laboratories. A "Life Support System" is any product or system intended to support or sustain life and/or health, which, if it fails, can be reasonably expected to result in significant personal injury or death. Silicon Laboratories products are generally not intended for military applications. Silicon Laboratories products shall under no circumstances be used in weapons of mass destruction including (but not limited to) nuclear, biological or chemical weapons, or missiles capable of delivering such weapons.

#### Trademark Information

Silicon Laboratories Inc., Silicon Laboratories, Silicon Labs, SiLabs and the Silicon Labs logo, CMEMS®, EFM, EFM32, EFR, Energy Micro, Energy Micro logo and combinations thereof, "the world's most energy friendly microcontrollers", Ember®, EZLink®, EZMac®, EZRadio®, EZRadioPRO®, DSPLL®, ISOmodem®, Precision32®, ProSLIC®, SiPHY®, USBXpress® and others are trademarks or registered trademarks of Silicon Laboratories Inc. ARM, CORTEX, Cortex-M3 and THUMB are trademarks or registered trademarks of ARM Holdings. Keil is a registered trademark of ARM Limited. All other products or brand names mentioned herein are trademarks of their respective holders.



Silicon Laboratories Inc.  
400 West Cesar Chavez  
Austin, TX 78701  
USA

<http://www.silabs.com>

## Looking for pricing, stock, or lifecycle information?

Click below to explore more details on WIN SOURCE:

 [View SI4706-D50-GMR](#) on WIN SOURCE

 [Silicon Labs](#) Information

## Optimize Your Supply Chain with WIN SOURCE Solutions

-  Global Sourcing Solution
-  Obsolete Management
-  Cost Control Management
-  Shortage Management
-  Alternative Solution
-  Excess Inventory Management