



**THE DATASHEET OF
DS9502P**



SPECIAL FEATURES

- Zener characteristic with voltage snap-back to protect against ESD hits
- High avalanche voltage, low leakage and low capacitance avoid signal attenuation
- Compatible to all 5V logic families
- Space saving, low inductance TSOC surface mount package
- Symmetric dual-port bondout to maximize energy dissipation in protection device
- Industrial temperature range

SYMBOL AND CONVENTIONS

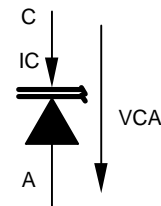

PACKAGE OUTLINE

TSOC SURFACE MOUNT PACKAGE

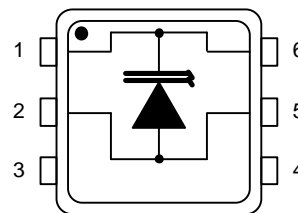

TOP VIEW

3.7 X 4.0 X 1.5 mm
 See Mech. Drawings
 Section

ORDERING INFORMATION

DS9502P 6-lead TSOC package

DESCRIPTION

This DS9502 was designed as an additional ESD protection for SRAM-based battery-buffered portable memory modules. The memory chips used for these modules have already a strong ESD-protection structure on their I/O line. Together with the DS9502 the ESD protection level is raised to more than 27 kV (IEC 801-2 Reference model). In case of abnormal ESD hits beyond its maximum ratings the DS9502 will eventually fail “short” thus preventing further damage.

During normal operation the DS9502 behaves like a regular 7.5V Zener Diode. When the voltage exceeds the trigger voltage, the I/V characteristic of the device will “snapback” allowing the same or higher amount of current to flow, but at a significantly lower voltage. As long as a minimum current or voltage is maintained, the device will stay in the “snapback mode”. If the voltage or the current falls below the holding voltage or holding current, the device will abruptly change to its normal mode and conduct only a small leakage current.

DC CHARACTERISTICS Figure 1

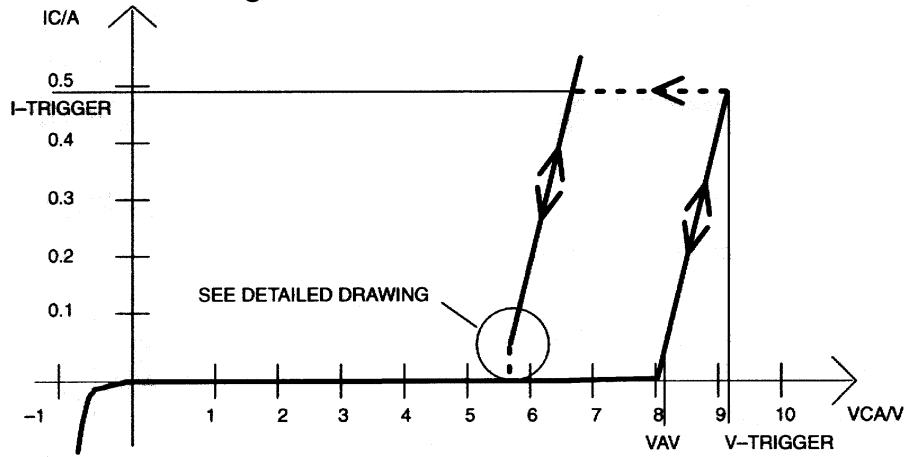

DC CHARACTERISTICS DETAIL DRAWING Figure 2

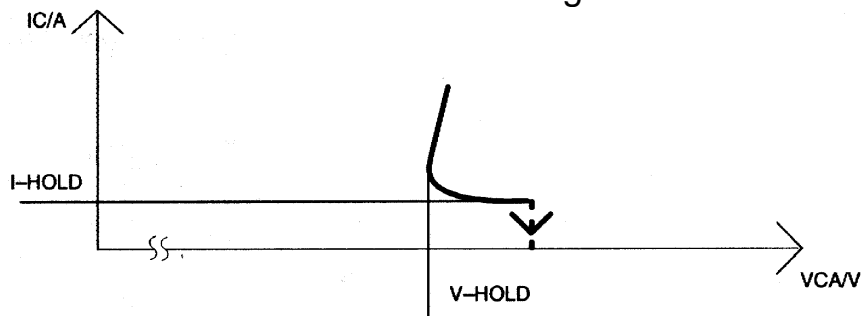

TEST PULSE WAVEFORM Figure 3

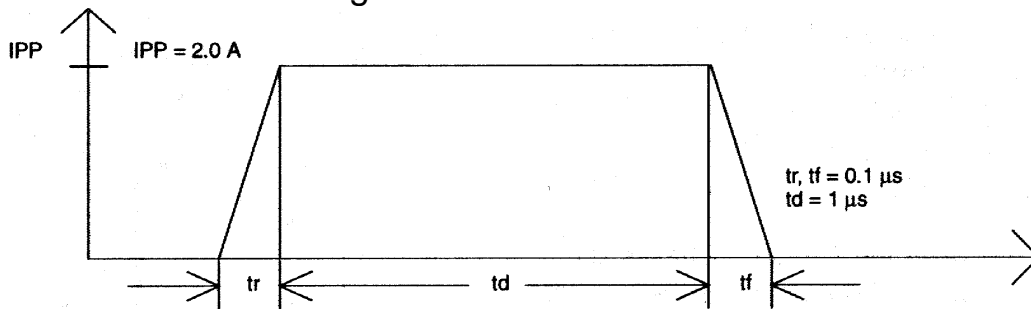

TYPICAL APPLICATION Figure 4

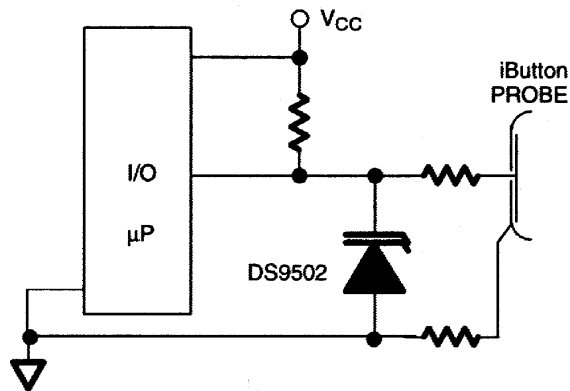

PHYSICAL SPECIFICATIONS

Size	See mechanical drawing
Weight	0.5 grams

ABSOLUTE MAXIMUM RATINGS*

Operating Temperature	-40°C to +85°C
Storage Temperature	-55°C to +125°C
Soldering Temperature	260°C for 10 seconds
Continuous DC Current Through Package	80 mA

* This is a stress rating only and functional operation of the device at these or any other conditions above those indicated in the operation sections of this specification is not implied. Exposure to absolute maximum rating conditions for extended periods of time may affect reliability.

ELECTRICAL CHARACTERISTICS

(-40°C to +85°C)

PARAMETER	SYMBOL	MIN	TYP	MAX	UNITS	NOTES
Leakage Current	I_L		30	100	nA	2
Avalanche Voltage	V_{AV}	7.4		7.8	V	1,3
Trigger Voltage	$V_{TRIGGER}$		9.0	9.5	V	1
Trigger Current	$I_{TRIGGER}$		600	1000	mA	
Holding Voltage	V_{HOLD}	5.5			V	1
Holding Current	I_{HOLD}	30			mA	
Forward Voltage (-10 mA)	V_F		-0.7	-0.8	V	4
Forward Current (-0.7V)	I_F		-10	-100	mA	4
Maximum Peak Current	I_{PP}		2.0		A	5
Continuous Current Through Diode	I_{CC}			±160	mA	6

CAPACITANCE(t_A=25°C)

PARAMETER	SYMBOL	MIN	TYP	MAX	UNITS	NOTES
Junction Capacitance (5V)	C_{J5}		55		pF	1
Junction Capacitance (0V)	C_{J0}		100		pF	1

THERMAL RESISTANCE



PARAMETER	SYMBOL	MIN	TYP	MAX	UNITS	NOTES
Junction To Package	$R_{\theta JC}$			75	K/W	
Junction To Ambient	$R_{\theta JA}$			200	K/W	

NOTES:

- All voltages are referenced from Cathode to Anode.
- At 7.0V.
- At 0.3 μA.
- Typical values at room temperature.
- See pulse specification.
- In either direction (forward or reverse) through the diode (pins 1 & 6 and 2 & 5 tied together, otherwise +80 mA max).

Looking for pricing, stock, or lifecycle information?

Click below to explore more details on WIN SOURCE:

-  [View DS9502P on WIN SOURCE](#)
-  [Maxim Integrated Information](#)

Optimize Your Supply Chain with WIN SOURCE Solutions

-  Global Sourcing Solution
-  Obsolete Management
-  Cost Control Management
-  Shortage Management
-  Alternative Solution
-  Excess Inventory Management