



THE DATASHEET OF UCD7138DRST



UCD7138 4-A and 6-A Single-Channel Synchronous-Rectifier Driver With Body-Diode Conduction Sensing and Reporting

1 Features

- Low-Side Gate Driver With Body-Diode Conduction Sensing
- Gate Turnoff Edge Body-Diode Conduction Reporting
- Gate Turnon Edge Delay Optimization
- Works Together With the Dead-Time Compensation (DTC) Module in the UCD3138A Family of Digital Power Controllers:
 - Automatic or Manual Dead-Time Adjustment of Gate Turnon and Turnoff Edges
 - Negative Current Protection
- -150-mV Body-Diode Conduction Sensing Threshold
- Able to Sense Body Diode Conduction Times as Low as 10 ns
- 4-A Peak-Source and 6-A Peak-Sink Drive Current
- Fast Propagation Delays (14-ns Typical)
- Fast Rise and Fall Times (5-ns Typical)
- Up to 2-MHz Operating Frequency
- 4.5-V to 18-V Supply Range
- Rail-to-Rail Drive Capability
- V_{CC} Undervoltage Lockout (UVLO)
- 6-Pin 3-mm x 3-mm WSON-6 Package

2 Applications

- LLC Converters
- Hard Switching Full-Bridge Converters
- Digital Power-Control Applications

4 Simplified Schematic

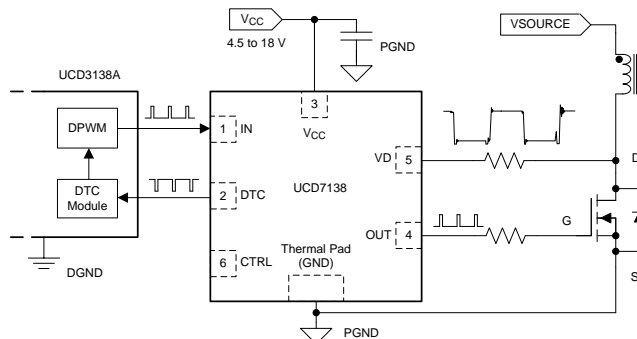

3 Description

The UCD7138 device is a 4-A and 6-A single-channel MOSFET driver with body-diode conduction sensing and reporting and is a high performance driver that allows the Texas Instruments UCD3138A digital PWM controller to achieve advanced synchronous-rectification (SR) control. The device contains a high-speed gate driver, a body-diode conduction-sensing circuit, and a turnon delay optimization circuit. The device is suitable for high-power, high-efficiency isolated converter applications where SR dead-time optimization is desired.

The UCD7138 device offers asymmetrical rail-to-rail 4-A source and 6-A sink peak-current drive capability. The short propagation delay and fast rise and fall time allows efficient operation at high frequencies. An internal high-speed comparator with a -150-mV threshold detects the body-diode conduction and reports the information to the UCD3138A digital-power controller. The UCD7138 device is capable of sensing body-diode conduction time as low as 10 ns. The SR turnon edge is optimized by the UCD7138 device. The SR turnoff edge is optimized by the UCD3138A digital-power controller which analyzes the body-diode conduction information reported by the UCD7138 DTC pin.

The benefits of the chipset include maximizing system efficiency by minimizing body-diode conduction time, robust and fast negative-current protection, and a simple interface.

Device Information⁽¹⁾

| PART NUMBER | PACKAGE | BODY SIZE (NOM) |
|-------------|----------|-------------------|
| UCD7138 | WSON (6) | 3.00 mm x 3.00 mm |

(1) For all available packages, see the orderable addendum at the end of the datasheet.

Power Savings for a 340-W LLC Application

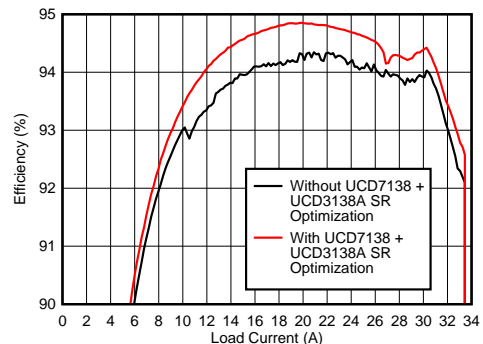

Table of Contents

| | | | |
|--|-----------|--|-----------|
| 1 Features | 1 | 8.3 Feature Description | 12 |
| 2 Applications | 1 | 8.4 Device Functional Modes | 14 |
| 3 Description | 1 | 9 Application and Implementation | 15 |
| 4 Simplified Schematic | 1 | 9.1 Application Information | 15 |
| 5 Revision History | 2 | 9.2 Typical Application | 15 |
| 6 Pin Configuration and Functions | 3 | 10 Power Supply Recommendations | 26 |
| 7 Specifications | 4 | 11 Layout | 26 |
| 7.1 Absolute Maximum Ratings | 4 | 11.1 Layout Guidelines | 26 |
| 7.2 ESD Ratings | 4 | 11.2 Layout Example | 27 |
| 7.3 Recommended Operating Conditions | 4 | 12 Device and Documentation Support | 28 |
| 7.4 Thermal Information | 4 | 12.1 Documentation Support | 28 |
| 7.5 Electrical Characteristics | 5 | 12.2 Community Resource | 28 |
| 7.6 Switching Characteristics | 6 | 12.3 Trademarks | 28 |
| 7.7 Typical Characteristics | 7 | 12.4 Electrostatic Discharge Caution | 28 |
| 8 Detailed Description | 11 | 12.5 Glossary | 28 |
| 8.1 Overview | 11 | 13 Mechanical, Packaging, and Orderable Information | 28 |
| 8.2 Functional Block Diagram | 11 | | |

5 Revision History

Changes from Revision A (April 2015) to Revision B

Page

| | |
|---|---|
| • Changed the device status from <i>Product Preview</i> to <i>Production Data</i> | 1 |
|---|---|

6 Pin Configuration and Functions

DRS Package
6-Pin WSON With Exposed Thermal Pad
Top View

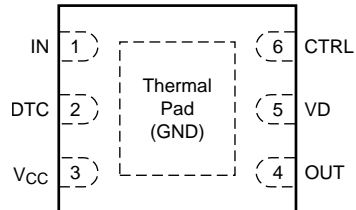

Pin Functions

| PIN | | TYPE | DESCRIPTION |
|-----|-------------------|------|---|
| NO. | NAME | | |
| 1 | IN | I | Input: Gate driver input. This pin should be connected directly to the DPWM output of the digital controller. |
| 2 | DTC | O | Body-diode conduction-time report: Standard digital IO. Pulled high internally. Output low when the body diode is conducting. This pin should be connected to the DTC0 or DTC1 pin on UCD3138A. |
| 3 | V _{CC} | P | IC supply: External bias supply input. The supply range is 4.5-V to 18-V. A ceramic bypass capacitor of at least 1 μF should be placed as close as possible to the V _{CC} pin and the thermal pad. Where possible, use thick & wide Cu connections. |
| 4 | OUT | O | Gate driver output: Integrated push-pull gate driver for one or more external power MOSFETs. Typical 4-A source and 6-A sink capability. This is a rail-to-rail output, with the rails defined by the voltages on V _{CC} and GND. This pin should be connected to the gate terminal of the synchronous rectification MOSFET. |
| 5 | VD | I | Drain voltage: Connect this pin as close as possible to the controlled-MOSFET drain pad. This pin is internally connected to the diode conduction detection comparator. The comparator has a –0.15-V threshold to detect body-diode conduction. A 20-Ω resistor should be connected between the VD pin and MOSFET drain terminal to limit the current. The maximum voltage of the VD pin should not exceed 45 V. A simple external circuit can enable the usage of much higher voltages, see Figure 34 . |
| 6 | CTRL | I | Rising edge optimization control: Connect this pin to ground to disable rising edge optimization. Leave this pin floating or connect it to logic high to enable rising edge optimization. |
| — | Thermal Pad (GND) | — | Exposed thermal pad: The exposed pad on the bottom of the package enhances the thermal performance of the device. This pad is the device ground reference. |

7 Specifications

7.1 Absolute Maximum Ratings

over operating free-air temperature range (unless otherwise noted) ⁽¹⁾

| | | MIN | MAX | UNIT |
|---|-----------------|------|------|------|
| Input voltage | V _{CC} | −0.3 | 20 | V |
| | IN, CRTL | −0.3 | 3.8 | |
| | VD | −1 | 45 | |
| Maximum V _{CC} continuous input current | DC current | | 50 | mA |
| Output current, peak (pulse) | | | 6 | A |
| Switching frequency, f _S | | | 2000 | kHz |
| Operating junction temperature, T _J | | −40 | 125 | °C |
| Lead temperature, soldering, 10 s, T _(SOL) | | | 300 | °C |
| Storage temperature, T _{stg} | | −65 | 150 | °C |

- (1) Stresses beyond those listed under *Absolute Maximum Ratings* may cause permanent damage to the device. These are stress ratings only, which do not imply functional operation of the device at these or any other conditions beyond those indicated under *Recommended Operating Conditions*. Exposure to absolute-maximum-rated conditions for extended periods may affect device reliability.

7.2 ESD Ratings

| | | VALUE | UNIT |
|--|--|-------|------|
| V _(ESD) Electrostatic discharge | Human body model (HBM), per ANSI/ESDA/JEDEC JS−001, all pins ⁽¹⁾ | ±2000 | V |
| | Charged device model (CDM), per JEDEC specification JESD22-C101, all pins ⁽²⁾ | ±500 | |

- (1) JEDEC document JEP155 states that 500-V HBM allows safe manufacturing with a standard ESD control process.
 (2) JEDEC document JEP157 states that 250-V CDM allows safe manufacturing with a standard ESD control process.

7.3 Recommended Operating Conditions

over operating free-air temperature range (unless otherwise noted)

| | | MIN | NOM | MAX | UNIT |
|-------------------|---|-----|-----|-----|------|
| V _{CC} | V _{CC} input voltage from a low impedance source | 4.5 | | 18 | V |
| V _{IN} | Input voltage | 0 | | 3.6 | V |
| C _(BP) | V _{CC} bypass capacitor | 1 | | | μF |
| T _J | Operating junction temperature | −40 | | 125 | °C |

7.4 Thermal Information

| THERMAL METRIC ⁽¹⁾ | | UCD7138 | UNIT |
|-------------------------------|--|------------|------|
| | | DRS (WSON) | |
| | | 6 PINS | |
| R _{θJA} | Junction-to-ambient thermal resistance | 73.4 | °C/W |
| R _{θJC(top)} | Junction-to-case (top) thermal resistance | 84.2 | |
| R _{θJB} | Junction-to-board thermal resistance | 46.3 | |
| ψ _{JT} | Junction-to-top characterization parameter | 2.6 | |
| ψ _{JB} | Junction-to-board characterization parameter | 46.4 | |
| R _{θJC(bot)} | Junction-to-case (bottom) thermal resistance | 12.4 | |

- (1) For more information about traditional and new thermal metrics, see the *Semiconductor and IC Package Thermal Metrics* application report, [SPRA953](#).

7.5 Electrical Characteristics

At $V_{CC} = 12 V_{DC}$, $-40^{\circ}C < T_J = T_A < 125^{\circ}C$, $1\mu F$ capacitor from V_{CC} to GND, all voltages are with respect to ground and currents are positive into and negative out of the specified terminal, unless otherwise noted. Typical values are at $T_J = 25^{\circ}C$.

| PARAMETER | | TEST CONDITIONS | MIN | TYP | MAX | UNIT |
|--|---|--|------|--------|-------|----------|
| VCC BIAS SUPPLY | | | | | | |
| $I_{CC(UV)}$ | V_{CC} current, undervoltage | $V_{CC} = 3.4 V$ | | 122 | 186 | μA |
| $I_{CC(ON)}$ | V_{CC} current, no switching | $V_{CC} = 12 V$ | | 0.85 | 1.1 | mA |
| $I_{CC(OPERATE)}$ | V_{CC} current, normal operation ⁽¹⁾ | $V_{CC} = 12 V$, $C_{(LOAD)} = 10 nF$, $f = 100 kHz$ | | 13 | 17 | mA |
| GATE INPUT (IN) | | | | | | |
| V_{IH} | Input signal high threshold | | 1.93 | 2.03 | 2.10 | V |
| V_{IL} | Input signal low threshold | | 0.98 | 1.03 | 1.08 | V |
| $V_{I(hys)}$ | Input hysteresis | | 0.90 | 1.00 | | V |
| DTC OUTPUT | | | | | | |
| $V_{OL(DTC)}$ | Low level output voltage | | | | 0.25 | V |
| $V_{OH(DTC)}$ | High level output voltage | | 2.5 | | | V |
| $I_{OH(DTC)}$ | Output sinking current | | | | 4 | mA |
| $I_{OL(DTC)}$ | Output sourcing current | | -4 | | | mA |
| V_{DTC} | Maximum DTC pin output voltage | | | 3.5 | 3.6 | V |
| UNDervoltage LOCKOUT SECTION (UVLO) | | | | | | |
| $V_{CC(ON)}$ | V_{CC} turnon threshold | | 3.30 | 3.80 | 4.30 | V |
| $V_{CC(OFF)}$ | V_{CC} turnoff threshold | | 3.10 | 3.56 | 4.02 | V |
| $V_{CC(hys)}$ | UVLO hysteresis | $V_{CC(hys)} = V_{CC(ON)} - V_{CC(OFF)}$ | | 0.24 | | V |
| COMPARATOR | | | | | | |
| V_{TH} | Body diode conduction sensing threshold | | -179 | -147 | -113 | mV |
| $C_{I(VD-ground)}$ | Differential input capacitance between VD and ground ⁽¹⁾ | $V_D = -150 mV$ | | 20 | | pF |
| GATE DRIVER | | | | | | |
| $V_{CC-V_{OH}}$ | Output high voltage | $I_{OUT} = -10 mA$ | | 0.038 | 0.064 | V |
| V_{OL} | Output low voltage | $I_{OUT} = 10 mA$ | | 0.0025 | 0.009 | V |
| $R_{(UP)}$ | Pullup resistance | $T_A = 25^{\circ}C$, $I_{OUT} = -25 mA$ to $-50 mA$ | | 5 | 6.1 | Ω |
| | | $T_A = -40^{\circ}C$ to $125^{\circ}C$, $I_{OUT} = -50 mA$ | | 5 | 6.3 | Ω |
| $R_{(DOWN)}$ | Pulldown resistance | $T_A = 25^{\circ}C$, $I_{OUT} = 25 mA$ to $50 mA$ | | 0.31 | 0.44 | Ω |
| | | $T_A = -40^{\circ}C$ to $125^{\circ}C$, $I_{OUT} = 50 mA$ | | 0.33 | 0.45 | Ω |
| $I_{O(source)}$ | Output peak current (source) ⁽¹⁾ | $C_{(LOAD)} = 0.22 \mu F$, $f_S = 1 kHz$, 5-V output | | -4 | | A |
| $I_{O(sink)}$ | Output peak current (sink) ⁽¹⁾ | $C_{(LOAD)} = 0.22 \mu F$, $f_S = 1 kHz$, 5-V output | | 6 | | A |

(1) Ensured by Design, not tested in Production.

7.6 Switching Characteristics

At $V_{CC} = 12 V_{DC}$, $-40^{\circ}C < T_J = T_A < 125^{\circ}C$, $1\mu F$ capacitor from V_{CC} to GND, all voltages are with respect to ground and currents are positive into and negative out of the specified terminal, unless otherwise noted. Typical values are at $T_J = 25^{\circ}C$.

| PARAMETER | | TEST CONDITIONS | MIN | TYP | MAX | UNIT |
|---------------|---|---|-----|------|------|------|
| t_r | Rise time | $C_{(LOAD)} = 1\text{ nF}$, $V_{CC} = 5\text{ V}$, See Figure 1 and Figure 24 | | 5 | 8 | ns |
| | | $C_{(LOAD)} = 1\text{ nF}$, $V_{CC} = 12\text{ V}$, See Figure 1 and Figure 24 | | 4 | 8 | ns |
| t_f | Fall time | $C_{(LOAD)} = 1\text{ nF}$, $V_{CC} = 5\text{ V}$, See Figure 1 and Figure 24 | | 3.36 | 5 | ns |
| | | $C_{(LOAD)} = 1\text{ nF}$, $V_{CC} = 12\text{ V}$, See Figure 1 and Figure 24 | | 3.5 | 5 | ns |
| $t_{w(VD)}$ | Minimum VD pulse duration (width) that changes the DTC output state | $V_{CC} = 5\text{ V}$ | | 10 | 23 | ns |
| | | $V_{CC} = 12\text{ V}$ | | 10 | 23 | ns |
| $t_{w(IN)}$ | Minimum IN duration (width) that changes OUT state | $V_{CC} = 5\text{ V}$ | | 11 | 13 | ns |
| | | $V_{CC} = 12\text{ V}$ | | 11 | 13 | ns |
| $t_{d(1)}$ | Gate driver turn on propagation delay | $C_{(LOAD)} = 1\text{ nF}$, $V_{IN} = 0\text{ V to } 3.3\text{ V}$, $V_{CC} = 5\text{ V}$, $V_{VD} = -0.5\text{ V}$, See Figure 1 and Figure 24 | | 14 | 26.6 | ns |
| | | $C_{(LOAD)} = 1\text{ nF}$, $V_{IN} = 0\text{ V to } 3.3\text{ V}$, $V_{CC} = 12\text{ V}$, $V_{VD} = -0.5\text{ V}$, See Figure 1 and Figure 24 | | 14 | 25 | ns |
| $t_{d(2)}$ | Gate driver turn off propagation delay | $C_{(LOAD)} = 1\text{ nF}$, $V_{IN} = 3.3\text{ V to } 0\text{ V}$, $V_{CC} = 5\text{ V}$, See Figure 1 and Figure 24 | | 14 | 22.9 | ns |
| | | $C_{(LOAD)} = 1\text{ nF}$, $V_{IN} = 3.3\text{ V to } 0\text{ V}$, $V_{CC} = 12\text{ V}$, See Figure 1 and Figure 24 | | 14 | 22 | ns |
| $t_{d(COMP)}$ | Body-diode conduction detection-comparator controlled-turnon propagation delay ⁽¹⁾ | $C_{(LOAD)} = 1\text{ nF}$, $V_{IN} = 3.3\text{ V}$, $V_{CC} = 5\text{ V}$, $V_{VD} = 2\text{ V to } -0.5\text{ V}$, See Figure 24 | | 28 | 36 | ns |
| | | $C_{(LOAD)} = 1\text{ nF}$, $V_{IN} = 3.3\text{ V}$, $V_{CC} = 12\text{ V}$, $V_{VD} = 2\text{ V to } -0.5\text{ V}$, See Figure 24 | | 26 | 33 | ns |
| $t_{d(DTC)}$ | DTC output propagation delay | $V_{CC} = 5\text{ V}$ | | 21 | 27 | ns |
| | | $V_{CC} = 12\text{ V}$ | | 18 | 25 | ns |

(1) For details about the operation, see the [Gate Turnon and Turnoff](#) section.

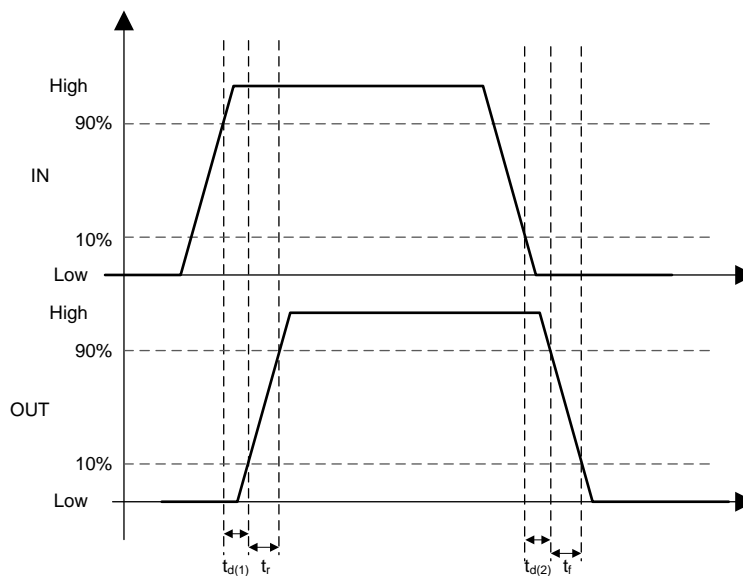
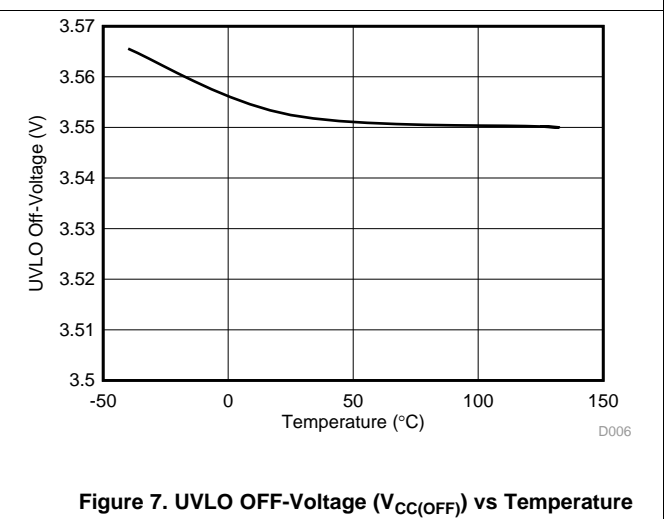
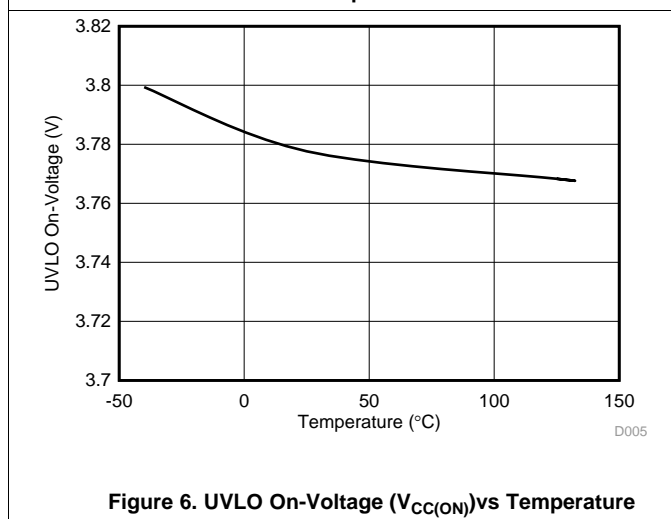
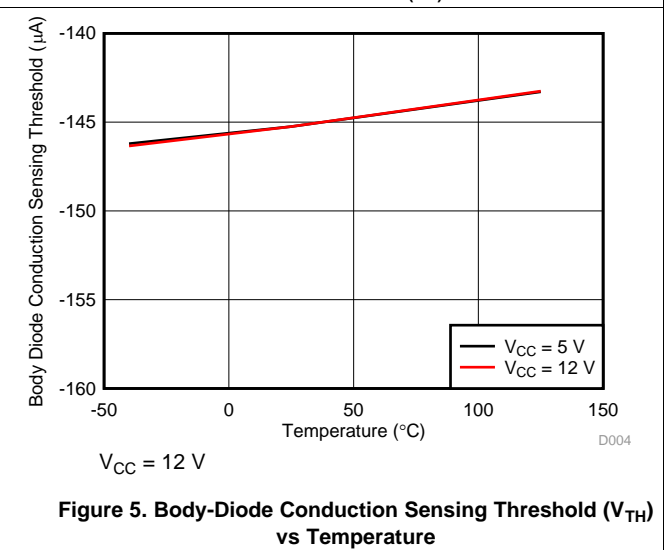
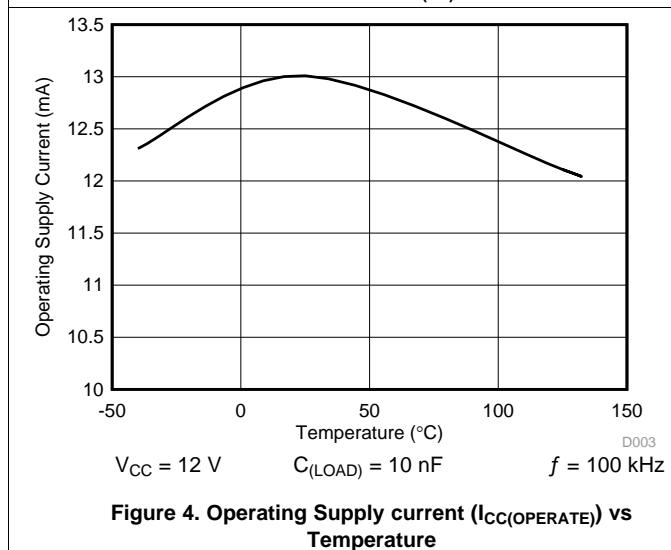
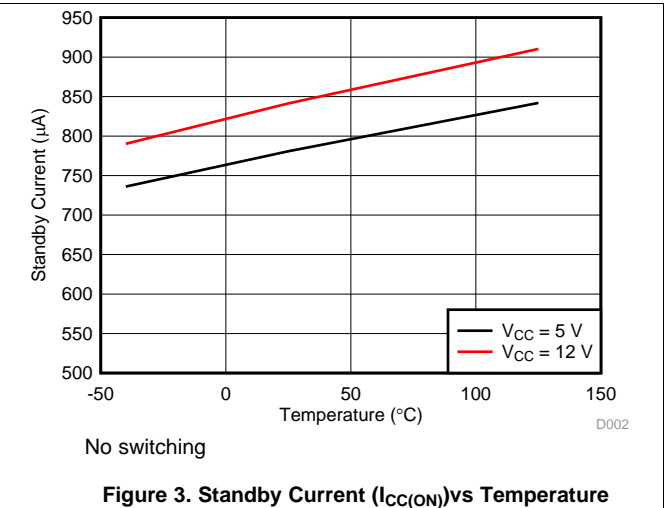
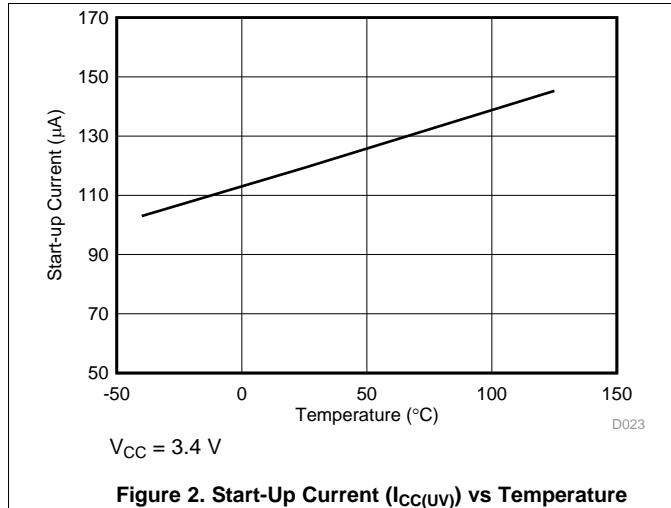
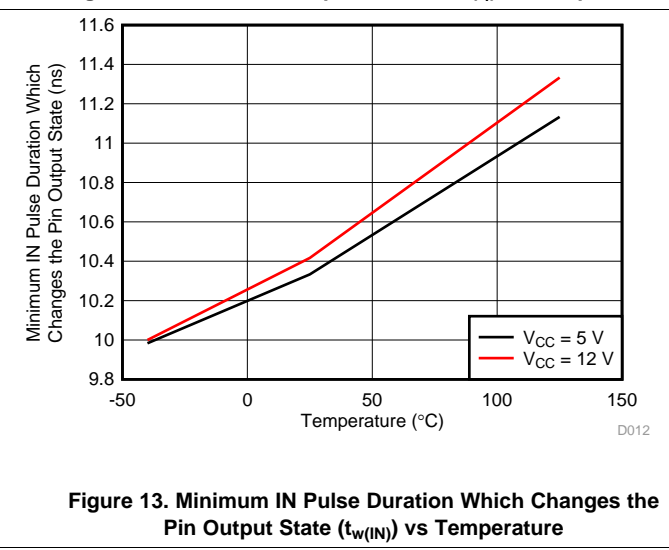
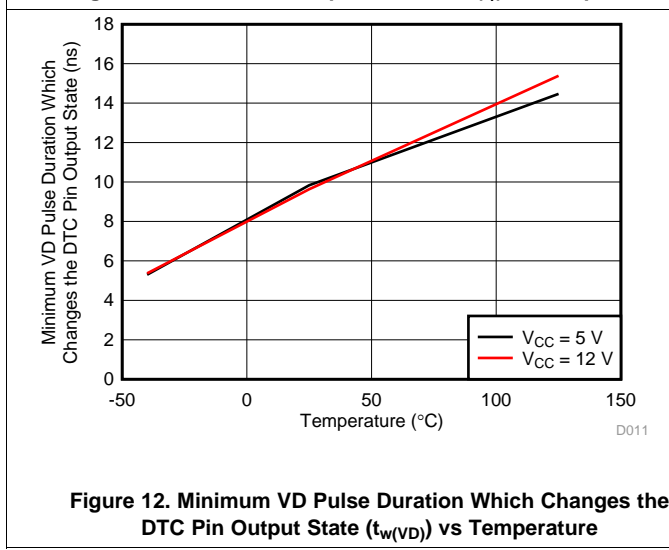
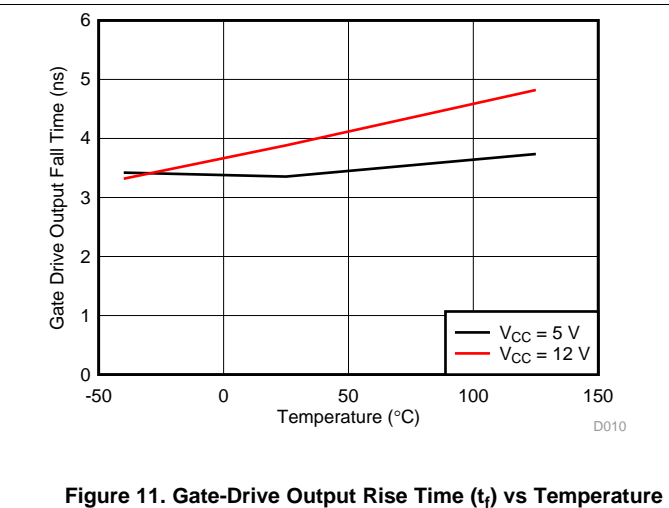
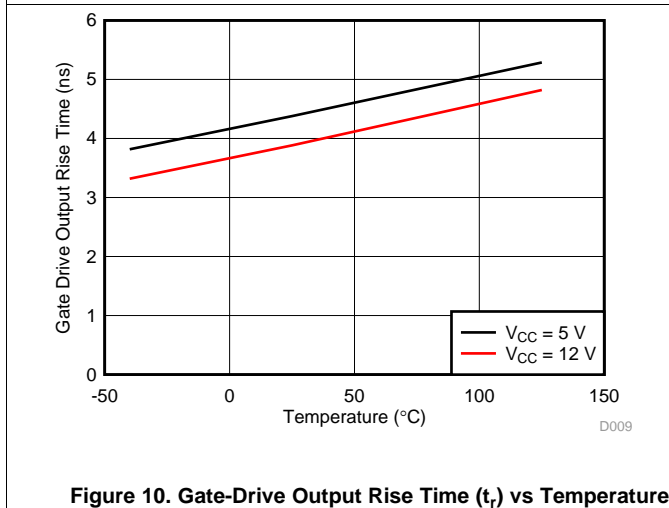
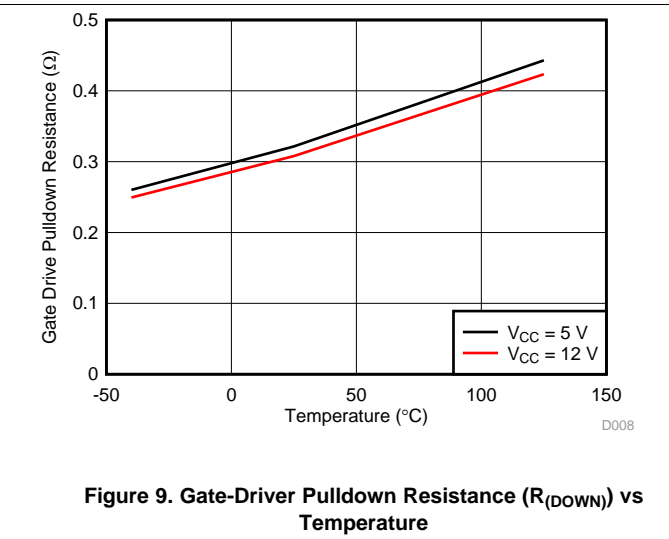
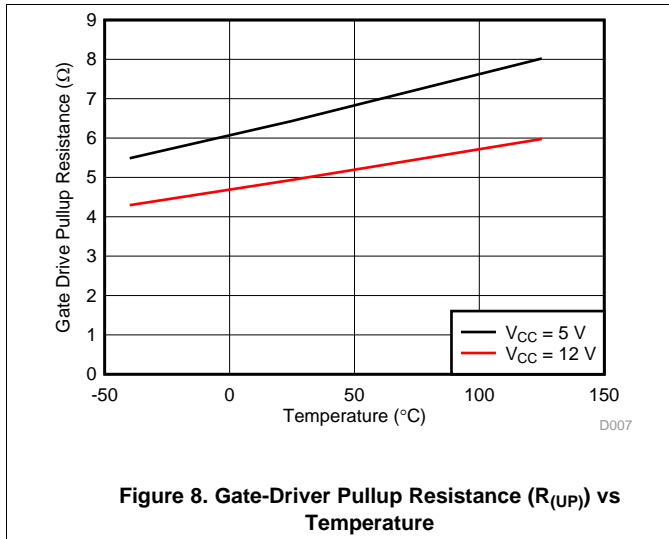

Figure 1. Input Driver Operation

7.7 Typical Characteristics



Typical Characteristics (continued)



Typical Characteristics (continued)

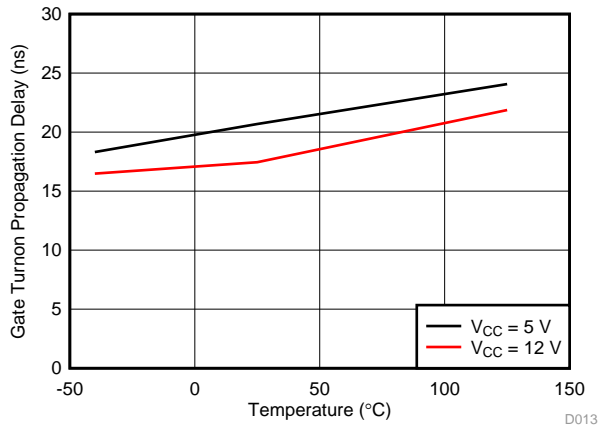

Figure 14. Gate Turnon Propagation Delay ($t_{d(1)}$) vs Temperature

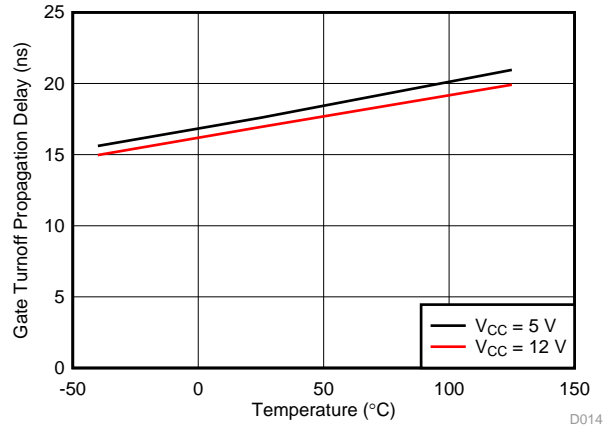

Figure 15. Gate Turnoff Propagation Delay ($t_{d(2)}$) vs Temperature

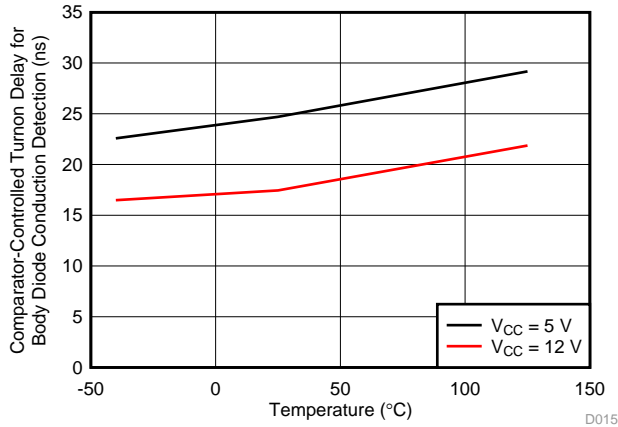

Figure 16. Comparator-Controlled Turnon Delay for Body Diode Conduction Detection ($t_{d(COMP)}$) vs Temperature

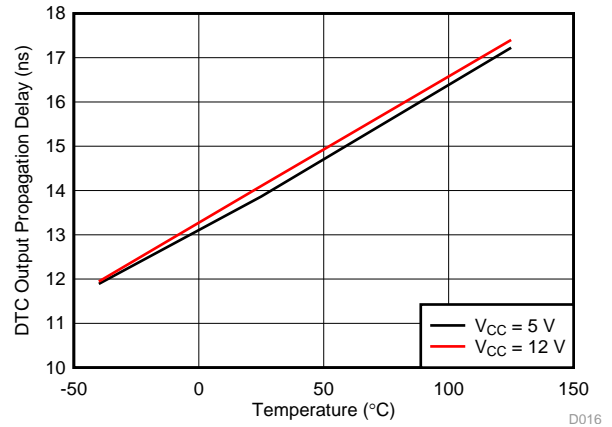

Figure 17. DTC Output Propagation Delay ($t_{d(DTC)}$) vs Temperature

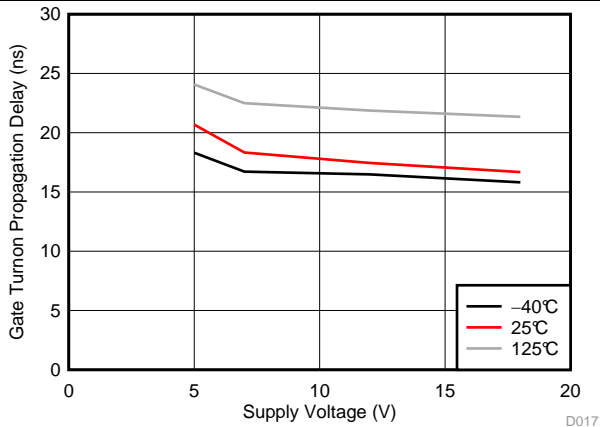

Figure 18. Gate Turnon Propagation Delay ($t_{d(1)}$) vs Supply Voltage (V_{CC})

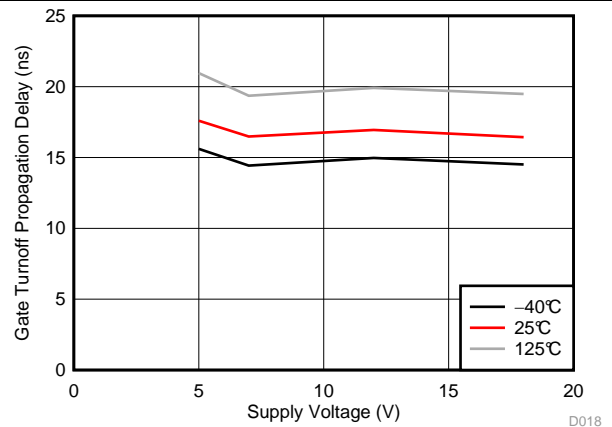

Figure 19. Gate Turnoff Propagation Delay ($t_{d(2)}$) vs Supply Voltage (V_{CC})

Typical Characteristics (continued)

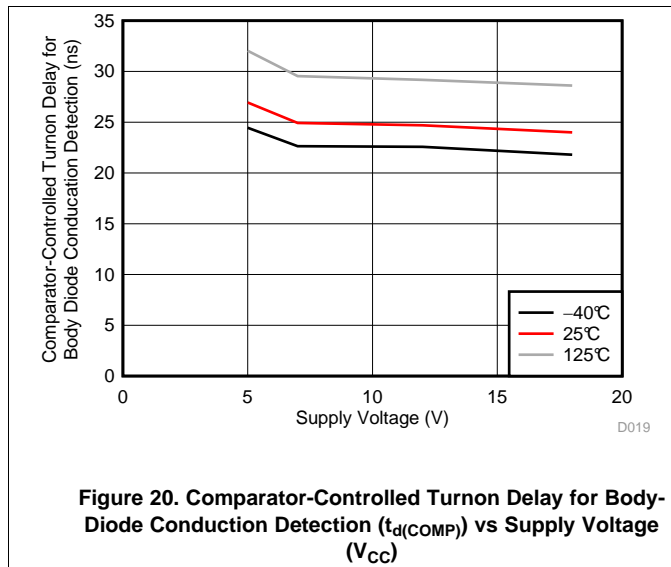

Figure 20. Comparator-Controlled Turnon Delay for Body-Diode Conduction Detection ($t_{d(COMP)}$) vs Supply Voltage (V_{CC})

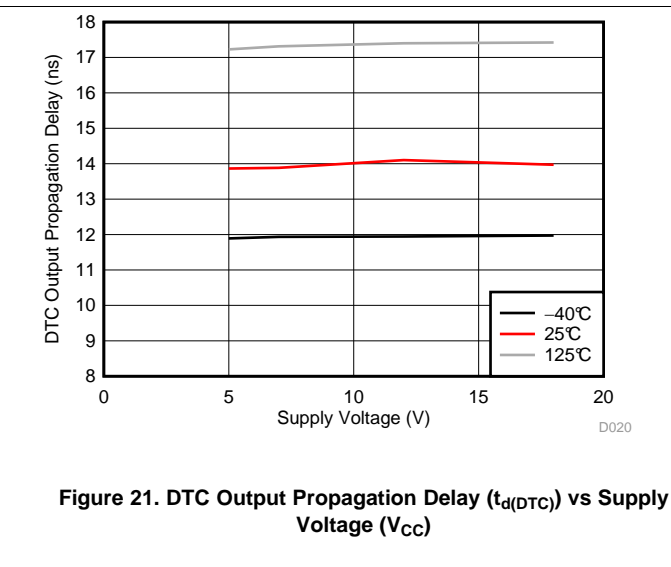

Figure 21. DTC Output Propagation Delay ($t_{d(DTC)}$) vs Supply Voltage (V_{CC})

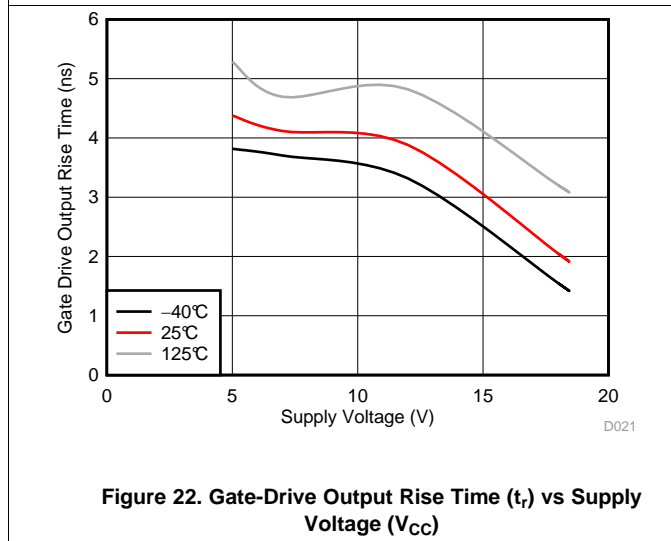

Figure 22. Gate-Drive Output Rise Time (t_r) vs Supply Voltage (V_{CC})

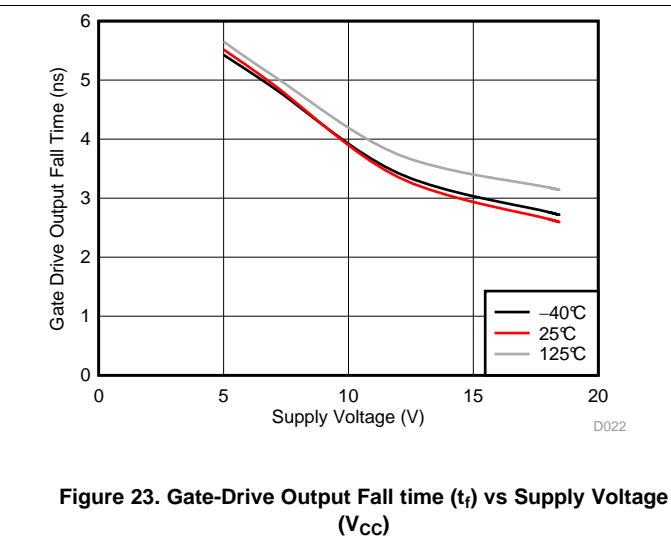

Figure 23. Gate-Drive Output Fall time (t_f) vs Supply Voltage (V_{CC})

8.3 Feature Description

8.3.1 Body-Diode Conduction Detection

In [Figure 24](#), V_{DS} is the drain-to-source voltage which is connected to the VD pin. The IN pin is the gate-driver input-command signal from the UCD3138A digital controller. The DTC pin is the sensed body-diode conduction. The OUT pin is the gate-driver output. The body-diode conduction detection comparator has a -150-mV threshold. When the body diode conducts, the DTC pin is low. If the body diode does not conduct, the DTC pin is high.

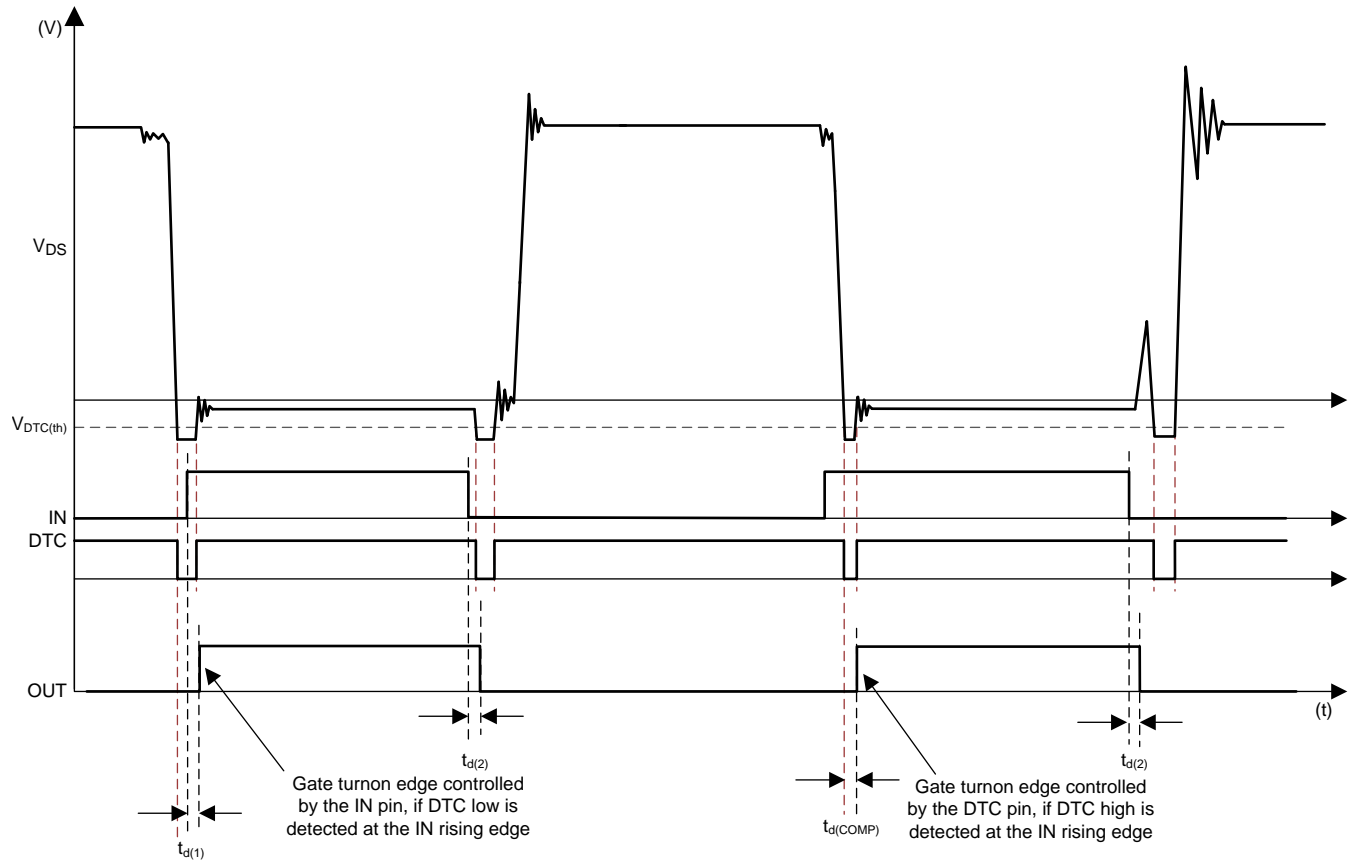

Figure 24. Input-Output Timing Diagram (Turn-On Optimization is Enabled)

To improve noise immunity, the comparator output DTC is blanked when the gate driver output, OUT, is high. The DTC signal always outputs high when OUT is high.

Feature Description (continued)

8.3.2 Gate Turnon and Turnoff

Gate turnon is controlled by both the gate driver input, IN, and body-diode conduction. System robustness is enhanced through internal logic that guarantees that OUT is only allowed high if IN is also high. At the IN rising edge, the UCD7138 gate-driver analyzes the DTC signal and determines the required course of action. The OUT pin is sent high immediately if the DTC comparator output is low at the rising edge of the IN signal. If the DTC pin is high at the rising edge of the IN signal, OUT is held low until DTC goes low. To allow the gate turnon edge to optimize freely, setting the dead time between the primary side falling edge and the IN rising edge smaller than expected in the UCD3138A digital controller is recommended.

The gate turnoff edge is determined by the IN signal only. The gate is turned off immediately at the IN falling edge.

Table 1. Truth Table for CTRL Pin Function

| CTRL PIN CONFIGURATION | FUNCTION |
|------------------------|-------------------------------|
| 0 V or ground | Turn-on optimization disabled |
| 3.3 V or floating | Turn-on optimization enabled |

8.3.3 V_{CC} and Undervoltage Lockout

The UCD7138 device has an internal undervoltage-lockout (UVLO) protection feature based on the V_{CC} -pin voltage. Whenever the driver is in the UVLO condition (such as when the V_{CC} voltage is less than $V_{CC(ON)}$ during power up or when the V_{CC} voltage is less than $V_{CC(OFF)}$ during power down), the device holds all outputs low, regardless of the status of the inputs. The UVLO voltage is typically 3.8 V with a 240-mV hysteresis. This hysteresis helps prevent chatter when low V_{CC} supply voltages have noise from the power supply and also when droops occur in the V_{CC} bias voltage.

For example, at power up, the UCD7138 driver output remains low until the V_{CC} voltage reaches the UVLO threshold. The magnitude of the OUT signal rises with V_{CC} until steady-state V_{CC} is reached. The output remains low until the UVLO threshold is reached. The DTC signal begins to rise when V_{CC} begins to rise. The internal diode conduction detection comparator remains inactive until V_{CC} passes $V_{CC(ON)}$ threshold.

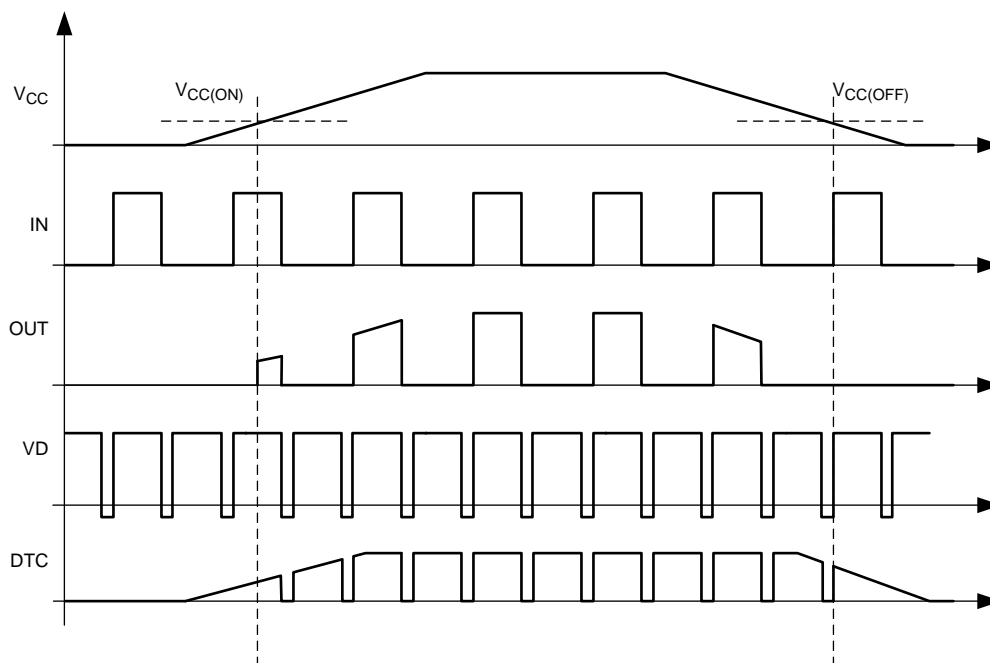

Figure 25. Device Power Up and Power Down

8.3.4 Operating Supply Current

The UCD7138 device features very-low quiescent supply current. The total supply current is the sum of the quiescent supply current, the average I_{OUT} current from switching, and any current related to pull-up resistors on the unused input pin. Knowing the operating frequency (f_S) and the MOSFET gate (Q_G) charge, the average I_{OUT} current can be calculated as product of Q_G and f_S .

8.3.5 Driver Stage

The input pins of the UCD7138 device are based on a CMOS-compatible input-threshold logic that is independent of the V_{CC} supply voltage. The logic-level thresholds can be conveniently driven with PWM control signals derived from 3.3-V.

The output stage of the UCD7138 device features a unique architecture on the pull-up structure. This architecture delivers the highest peak-source current when needed during the Miller-plateau region of the power switch turnon transition (when the power switch drain or collector voltage experiences dV/dt). The output stage pull-up structure features a P-Channel MOSFET and an additional N-Channel MOSFET in parallel. The function of the N-Channel MOSFET is to provide a brief boost in the peak sourcing current to enable fast turnon. This boost occurs by briefly turning on the N-Channel MOSFET when the output is changing state from LOW to HIGH.

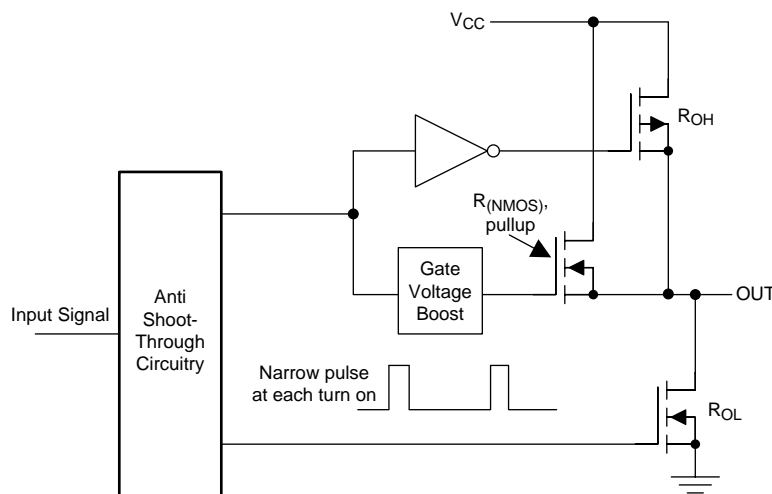

Figure 26. Gate-Driver Output Structure

8.4 Device Functional Modes

8.4.1 UVLO Mode

When the V_{CC} voltage to the device has not reached the $V_{CC(ON)}$ threshold or has fallen below the UVLO threshold, $V_{CC(OFF)}$, the device operates in the low-power UVLO mode. In this mode, most internal functions are disabled and the I_{CC} current is very low. In UVLO mode, the OUT pin is held low. The device passes out of UVLO mode when the V_{CC} voltage increases above the $V_{CC(ON)}$ threshold.

8.4.2 Normal Operation Mode

In this mode, the I_{CC} current is higher because all internal control and timing functions are operating and the gate-driver output, OUT, is driving the controlled MOSFET for synchronous rectification. In this mode, the V_{CC} current is the sum of $I_{CC(ON)}$ plus the average current required to drive the load on the OUT pin.

9 Application and Implementation

NOTE

Information in the following applications sections is not part of the TI component specification, and TI does not warrant its accuracy or completeness. TI's customers are responsible for determining suitability of components for their purposes. Customers should validate and test their design implementation to confirm system functionality.

9.1 Application Information

The UCD7138 device can be used in a wide range of applications. The device can be used on many center-tapped secondary-side rectification topologies. Specifically, the device can be used in half-bridge LLC converters. In these applications, the UCD3138A and UCD7138 chipset enables the synchronous rectifiers to closely approximate the behavior of an ideal diode which is difficult to do in an LLC converter because of the variations in the SR current-conduction time.

The UCD7138 and UCD3138A chipset together can provide an easy-to-use, high-performance and advanced SR-control solution. Without this solution, fine tuning is required for each operation region (including below resonant frequency, at resonant frequency, and above resonant frequency). For LLC converters in production, each power stage may have a different resonant frequency because of tolerances of circuit capacitors and inductors. Calibration is required for each converter to achieve high efficiency. With UCD7138 and UCD3138A advanced SR control, optimal SR operation is easily achieved for every converter without fine tuning and calibration of the resonant tank can be eliminated in production. For more information see *Using UCD7138 and UCD3138A for Advanced Synchronous Rectification Control*, [SLUA737](#).

9.2 Typical Application

9.2.1 Half-Bridge LLC

[Figure 27](#) shows a typical half-bridge LLC application using the UCD7138 device as a secondary-side SR driver and the UCD3138A device as a controller.

Typical Application (continued)

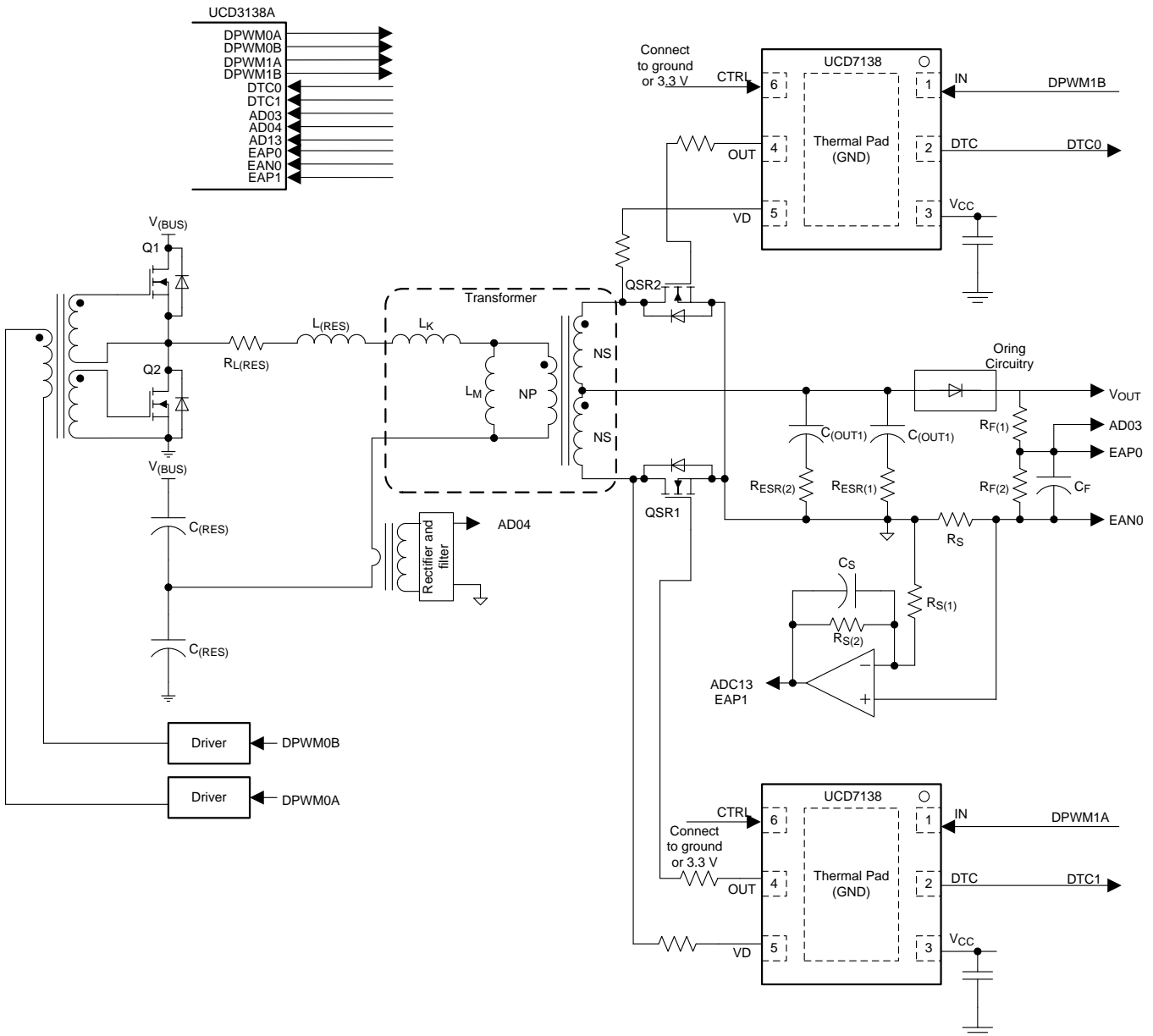

Figure 27. Half-Bridge LLC Typical Application Diagram

In LLC converters, if the SRs are not well optimized, the SR conduction time can either be too long or too short. The duration of the body diode conduction time can be determined by examining the drain-to-source voltage of the MOSFET when it is off. The SR turnon edge is optimized by the UCD7138 device by turning the gate on as soon as body-diode conduction is sensed. The SR turnoff edge is determined when the UCD3138A digital controller analyzes the sensed body-diode conduction time. Figure 28 shows the typical drain-to-source waveforms on a half-bridge LLC converter and the desired waveforms.

Typical Application (continued)

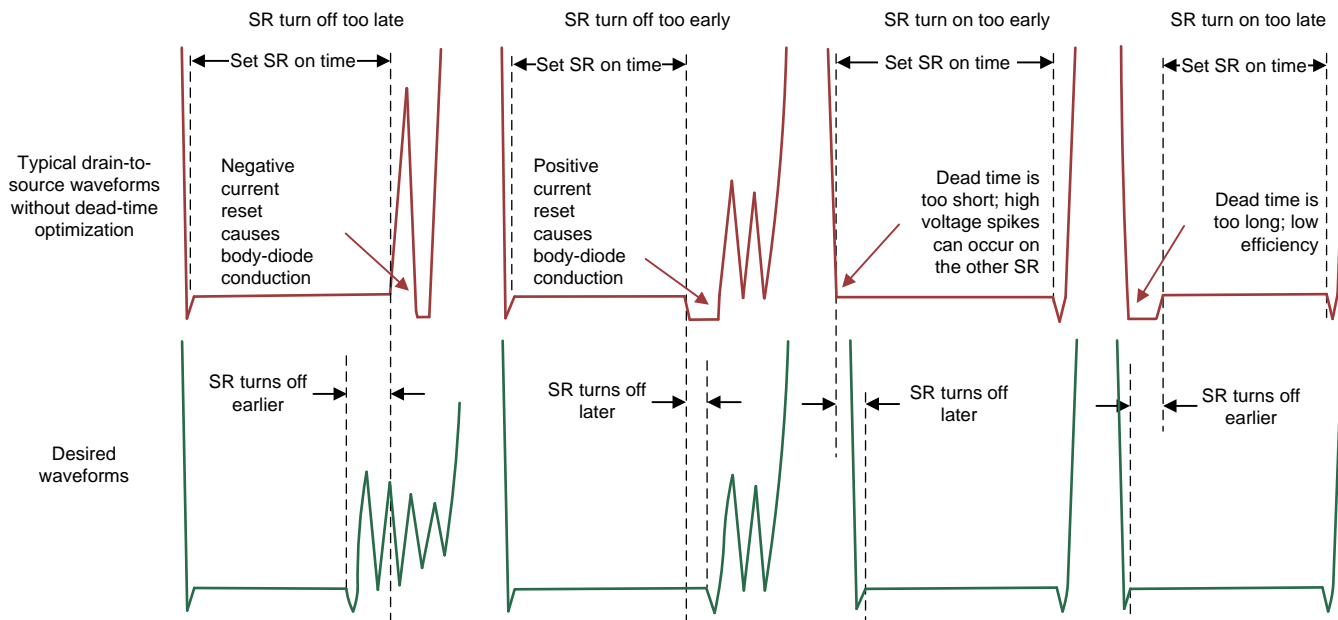

Figure 28. Drain to Source Voltage Waveforms in a Typical Half Bridge LLC Application and Desired Waveforms

As shown in [Figure 29](#), when the SR pulse is on for too long, the drain-to-source voltage shoots up. The upper waveform in [Figure 29](#) shows the SR current. The lower waveform shows the SR drain-to-source voltage. The black segment of the curves show when the SR MOSFET is on. The red and green segments of the curves show when the SR MOSFET is off. The SR current is positive at first, but continues to drop until it is negative. The drain-to-source voltage is close to 0 V when the SR MOSFET is on. As soon as the SR MOSFET is turned off, the negative current must reset. The capacitance across the drain and source terminal is charged, and the drain-to-source voltage increases. The green segments of the curves show when the negative current reset process is complete at which point the body diode of the MOSFET conducts briefly again.

Typical Application (continued)

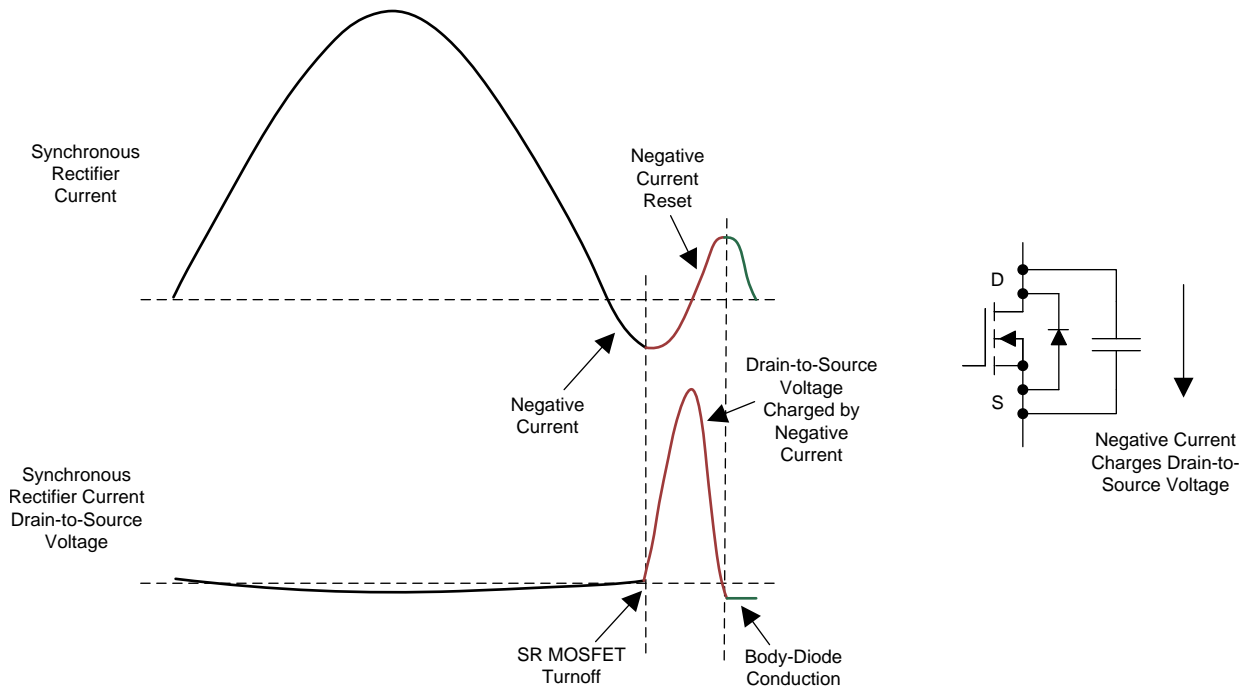

Figure 29. SR Drain-to-Source Voltage Shoot Up When No Negative Current Flow Occurs

For the UCD3138A device, a DTC detection window is generated at the falling edge of the gate drive command IN signal. Only during this detection window is the DTC low time counted by a 4-ns resolution timer capture inside the UCD3138A device. Figure 30 shows the simplified system block diagram. In the two body-diode conduction cases shown in Figure 31, the SR on time should be adjusted in different directions. The detection window identify that these two cases are different. If, during the detection window, a large amount of DTC low time is detected, and the SR turns off too early. If, during the detection window, no or very-short DTC low time is detected and the SR turns off too late.

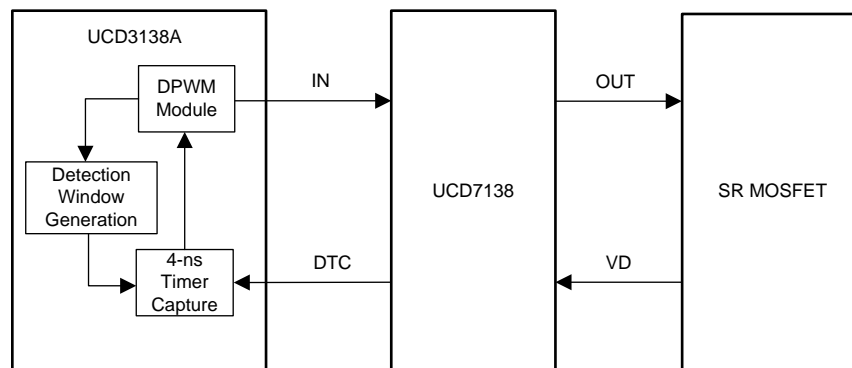

Figure 30. Simplified System Block Diagram

Typical Application (continued)

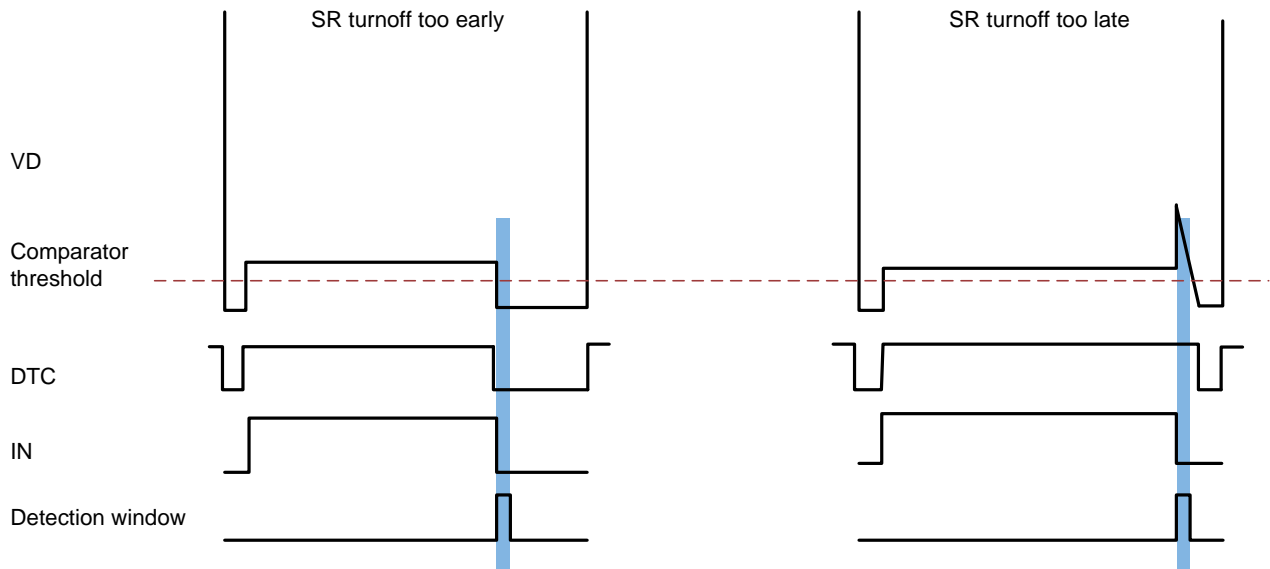

Figure 31. Body-Diode Connection Detection

The UCD3138A digital controller counts the body-diode conduction time of the current cycle and adjusts the SR on time of the next cycle. In Figure 32, the DTC0 and DTC1 signals are the body-diode conduction inputs received from the UCD7138 device. SR0_DPWM and SR1_DPWM are the DPWM waveforms for the SRs. The red and green dashed lines are moving edges controlled by both the UCD3138A digital-compensator output and the DTC interface. In each cycle, directly after the falling edge of the SR DPWM waveform, a detection window is generated for the body-diode conduction time. The detection window is defined by both DETECT_BLANK and DETECT_LEN registers. During this detection window, a 4-ns timer capture counts the conduction time of the body diode. The SR DPWM turnoff edge of the next cycle is then adjusted accordingly.

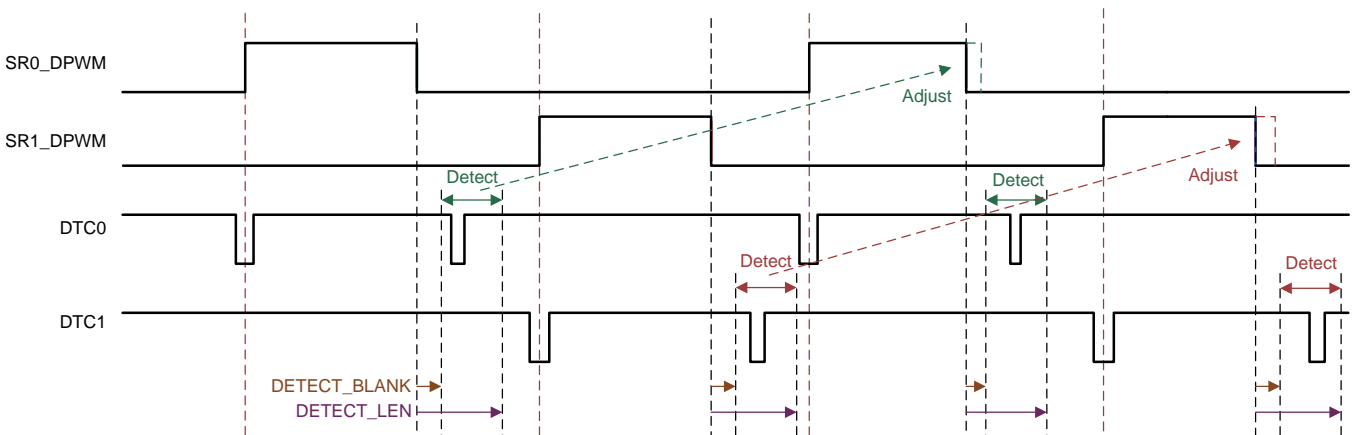

Figure 32. Timing Diagram of the DTC Interface in UCD3138A

Typical Application (continued)

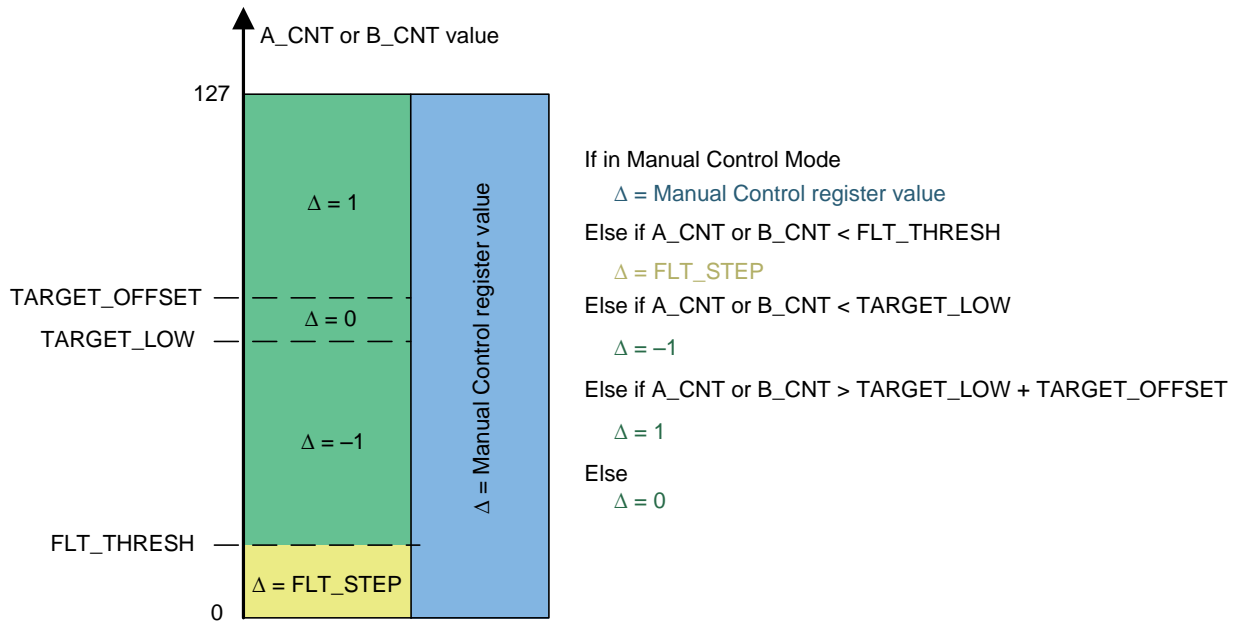

Figure 33. DTC Interface Principle

Figure 33 shows how the SR turnoff edge is adjusted based on the DTC measurement of the previous cycle. The A_CNT or B_CNT is the counted values of diode conduction time of two SRs which ranges from 0 to 127. The two types of SR control modes are automatic-control mode and manual-control mode. If manual-control mode is used, the SR on-time adjustment value is determined by the manual write register. If automatic-control mode is used, the UCD3138A digital controller automatically calculates the SR on-time adjustment amount for the next cycle. The body-diode conduction time at the falling edge of the SR gate is regulated to a target value by step-by-step edge adjustment in the UCD3138A device. The SR on time is reduced by a preprogrammed large amount, when the sensed body-diode conduction time is less than a programmable threshold. This reduction prevents the power supply from damaged caused by negative current in the SRs.

For more information on the DTC interface on UCD3138A see *UCD7138 and UCD3138A for Advanced Synchronous Rectification Control*, [SLAU737](#) and *UCD3138A Highly Integrated Digital Controller for Isolated Power*, [SLUSC66](#).

9.2.1.1 Design Requirements

9.2.1.1.1 Gate Input

The input stage of the driver should be driven by a signal with fast rise and fall times. Caution must be exercised whenever the driver is used with slowly varying input signals, in situations where the device is located in a mechanical socket or PCB layout is not optimal (bad grounding, for example). Ground bounce is often caused by high di/dt current from the driver output, coupled with board-layout parasitic. The differential voltage between the input pin IN and ground pad GND may be modified by ground bounce and trigger an unintended change of output state. Because of short propagation delay, the unintended change of state can ultimately result in high-frequency oscillations, which increases power dissipation and can potentially damage the device. In the worst case, when a slow input signal is used and PCB layout is not optimal, adding a small capacitor (1 nF) between the input pin and ground very close to the driver device may be necessary.

9.2.1.1.2 Gate Output

The output of the gate driver (OUT) must be connected as close to the MOSFET gate as possible. A small resistor may be connected in between to reduce the high-frequency oscillations on the gate. Doing so can also slow down the gate transitions. The DTC detection windows inside UCD3138A may need some adjustment to compensate for the delay caused by the added resistor.

Typical Application (continued)

9.2.1.1.3 Drain-to-Source Voltage Sensing

When the drain-to-source voltage is below 0 V, current flows out of the VD pin to the drain terminal of the MOSFET. This current flow must be limited to ensure proper operation of the device. The recommended current-limiting resistance value is 20Ω.

The highest voltage that can be applied to VD pin is 45 V which is good for applications where 40-V MOSFETs are used for the secondary-side SRs. If a higher voltage is required for VD pin, an external high-voltage blocking circuit can be used together with the UCD7138 device as shown in Figure 34. Depending on the required voltage rating, a different external high-voltage blocking MOSFET can be selected. Usually a small SOT-23 MOSFET can be used. In this circuit, the gate terminal of the external high-voltage blocking MOSFET is connected to V_{CC} of the UCD7138 gate driver. The source terminal is connected with a current-limiting resistor to the VD pin of the UCD7138 device. The drain terminal is connected to the SR MOSFET drain terminal. When a low voltage is presented at the drain terminal, the blocking MOSFET is turned on because of the positive gate-to-source voltage. When the drain voltage becomes higher and higher, the source terminal voltage rises along with the drain terminal until the gate-to-source voltage falls below the threshold. When the source voltage is high enough so that the blocking MOSFET is turned off, the high voltage on the SR drain is blocked.

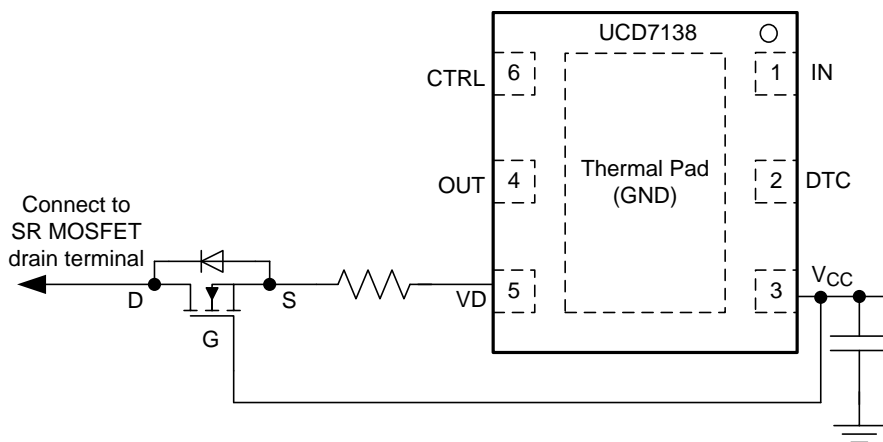

Figure 34. External High-Voltage Blocking Circuit

9.2.1.1.4 DTC Output

The DTC pin is the internal comparator output. This pin should be connected to the DTC0 or DTC1 pin on the UCD3138A device. To keep edges sharp, no filtering is recommended. If noise spikes are observed on the DTC signal, the blanking times in the UCD3138A device can be used to prevent the digital controller from sensing noise. This pin is not designed to drive large current. If filtering must be used, ensure that the sink and source current on this pin is within ±4 mA as specified in the

[Electrical Characteristics](#) table.

9.2.1.1.5 Turn-on Edge Optimization

The turnon edge optimization is useful when a positive current flow is at the rising edge of SRs. To maximize the efficiency gain, the dead time between the falling edge of the primary and the rising edge of the secondary should be programmed to a smaller value than expected, so that the rising edge of the SRs can move freely by UCD7138.

9.2.1.2 Detailed Design Procedure

9.2.1.2.1 Design Without SR-Control Optimization

The design procedure of an LLC converter with synchronous rectification can be greatly simplified by using the UCD7138 and UCD3138A chipset. The converter hardware and firmware can initially be designed without advanced SR optimization and then add SR optimization function in.

Typical Application (continued)

For more information on the UCD3138A-based digital LLC converter, *UCD3138A Highly Integrated Digital Controller for Isolated Power*, [SLUSC66](#).

9.2.1.2.2 Setting the DTC Detection Window

The body-diode conduction should be detected in a specific region for the system to operate correctly. The detection window is defined by a blanking time register `DETECT_BLANK` and a detection length register `DETECT_LEN` in the UCD3138A device. To set the detection window, let the LLC converter operate below resonant frequency. Measure the VD, IN, and DTC waveforms on an oscilloscope. Use cursors to measure the time, t , difference between the IN falling edge and the starting point of body-diode conduction (first falling edge of DTC excluding noise spike). The blanking time should be set to be less than t . Usually the required blanking time is very short or non-existent, so the blanking time can be set to around 10% of t . The detection window length can be set to a few times of the desired body-diode conduction time. For example, if the desired body-diode conduction time is 40 ns, the detection window length can be set to 120 ns. Make sure that the body-diode conduction is well covered inside the detection window when it is at an optimal value. The end point of the detection window should never exceed the first valley on the VD waveform to avoid errors in measurement (see [Figure 35](#)).

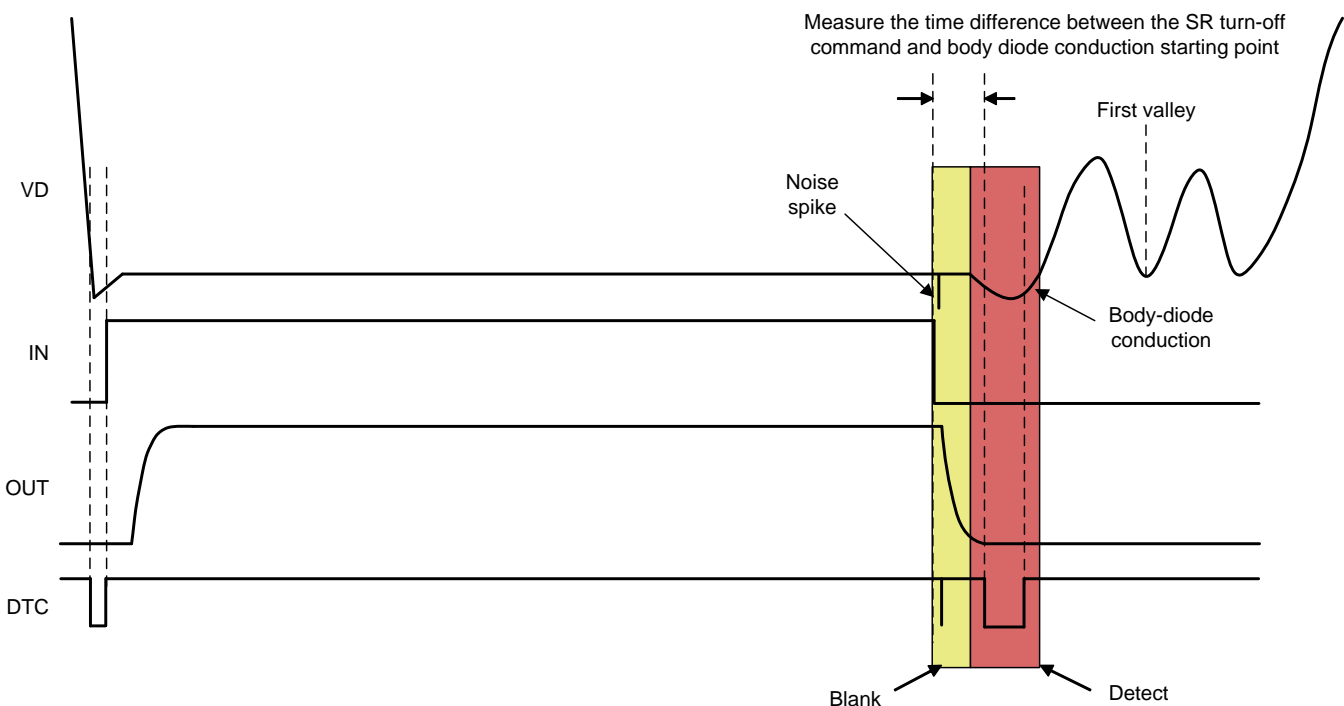

Figure 35. Setting the DTC Detection Window in UCD3138A

After the detection window is set, enable the DTC module in manual control mode. Set the offset in the manual control registers to 0. Change the input voltage and load current to different operation points to verify that the UCD3138A DTC module measures the correct values in the `A_CNT` and `B_CNT` registers. See the *UCD3138A64 Programmer's Manual*, [SLUUB54](#) for detailed register information.

9.2.1.2.3 Setting the Clamps

The SR adjustment accumulator clamps defines the maximum SR turnoff edge offset from the calculated value from the UCD3138A compensator. The maximum clamp can be set to prevent the SR on time from going too long and causing shoot through. The minimum clamp can be set based on the light load condition where the desired SR turnoff edge offset is the maximum.

In addition to the SR adjustment accumulator clamps, the SR pulse falling edge is naturally clamped at 50% or 100% or the switching period in UCD3138A. This natural clamp is a default feature of UCD3138A and does not require any special setting.

Typical Application (continued)

9.2.1.2.4 Setting the DTC Optimization Target and Hysteresis

The body diode must maintain a minimum conduction time for the UCD3138A DTC interface to function properly. The minimum body-diode conduction time is set by the DTC target and target register. A target hysteresis register can also be set to reduce the steady-state output-voltage ripple.

9.2.1.2.5 Setting the DTC Negative Current Fault Protection

If the detected body-diode conduction time is less than the programmed threshold, negative current can occur. This threshold can be set by the fault threshold register in the UCD3138A DTC module. If a DTC fault is detected, the SR on time is reduced by a programmed step size in the next switching cycle. This step size is defined by FLT_STEP register in the DTC module. To avoid noise and jitter in the negative current fault detection, a consecutive DTC fault counter can be used. A fault step is executed only after a consecutive number of faults are detected.

After all these registers are set, enable the UCD3138A DTC module in automatic control mode, enable the turnon-edge optimization on the UCD7138 device, and review the different operation conditions to see the overall system performance. The DTC module can be turned on or off by toggling DTC_EN bit in Loop Mux register in UCD3138A. The performance before and after SR optimization control can be compared very easily as shown in the [Application Curves](#) section.

Typical Application (continued)

9.2.1.3 Application Curves

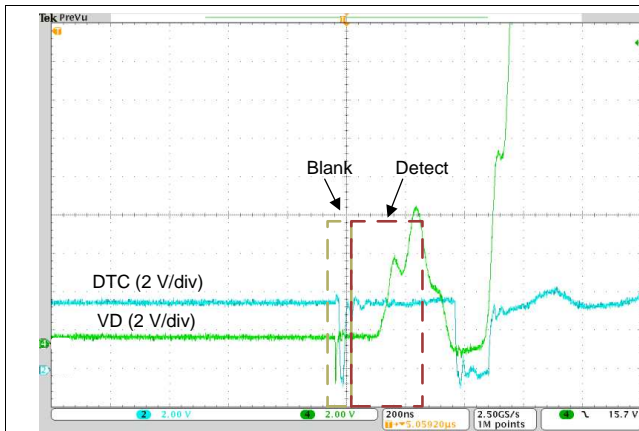

No optimization, SR on time too long.
High V_{DS} stress on the other SR.
Horizontal: 200 ns/div

Figure 36. SR Turnoff Edge Before Optimization

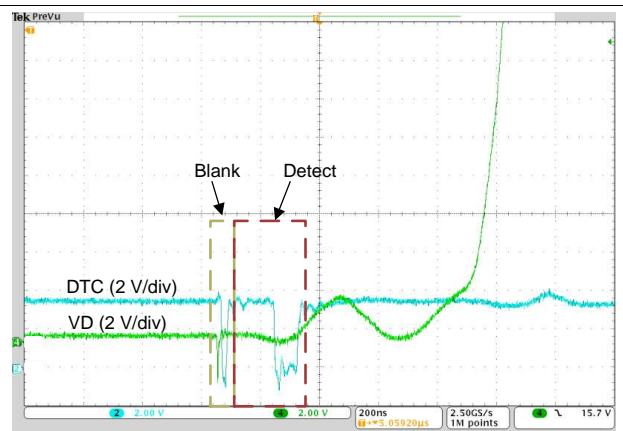

With optimization
Horizontal: 200 ns/div

Figure 37. SR Turnoff Edge After Optimization

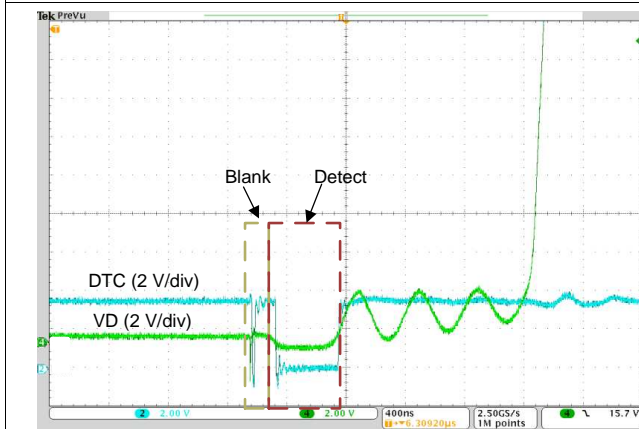

No optimization, SR on time too short. Low efficiency.
Horizontal: 200 ns/div

Figure 38. SR Turnoff Edge Before Optimization

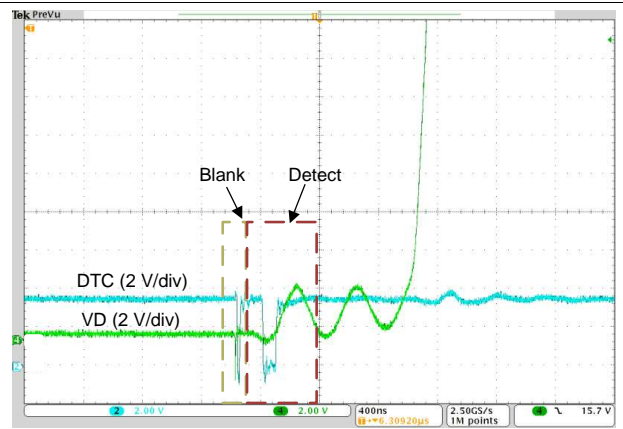

With optimization
Horizontal: 200 ns/div

Figure 39. SR Turnoff Edge After Optimization

Typical Application (continued)

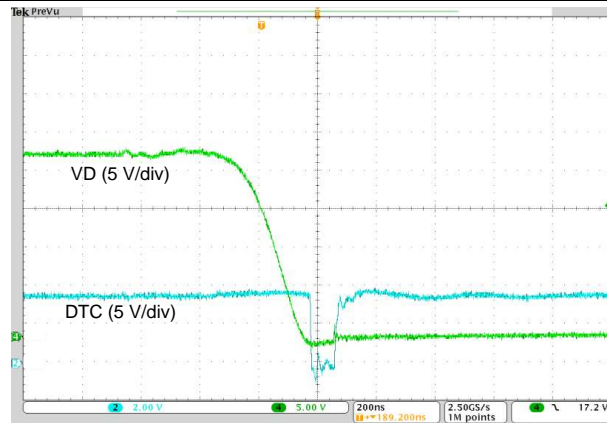

No optimization, SR on turnon too late. Low efficiency.
Horizontal: 200 ns/div

Figure 40. SR Turnon Edge Before Optimization

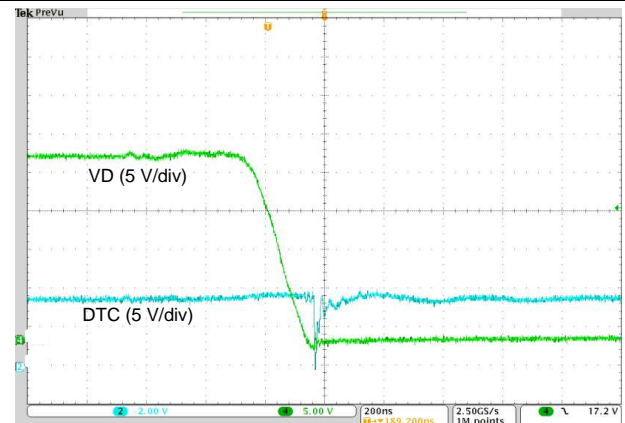

With optimization
Horizontal: 200 ns/div

Figure 41. SR Turnon Edge After Optimization

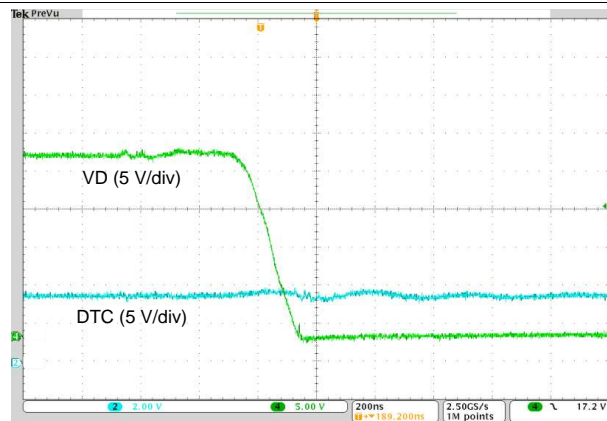

No optimization, SR turnon too early.
Horizontal: 200 ns/div

Figure 42. SR Turnon Edge Before Optimization

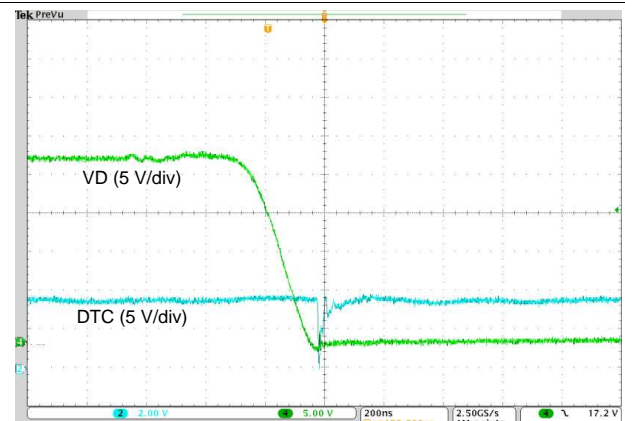

With optimization
Horizontal: 200 ns/div

Figure 43. SR Turnon Edge After Optimization

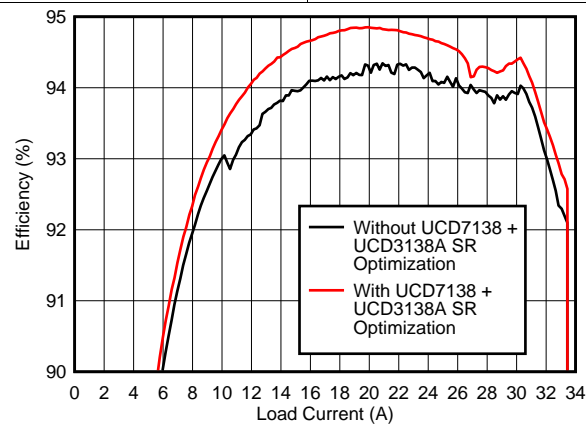

Efficiency increase at peak efficiency: 0.54% Peak efficiency increase (occurs at no-load): 2.62%
Average efficiency increase over constant voltage load range: 0.63%
Peak efficiency with and without SR optimization: 94.85% at 19.92 A

Figure 44. Efficiency Comparison with and without UCD7138 + UCD3138A Advanced SR Control

10 Power Supply Recommendations

Because the driver draws current from the V_{CC} pin to bias all internal circuits, for the best high-speed circuit performance, two V_{CC} bypass capacitors are recommended to prevent noise problems. The use of surface-mount (SM) components is highly recommended. A 1 μ F ceramic capacitor should be placed as close as possible to the V_{CC} to ground pad of the gate driver.

11 Layout

11.1 Layout Guidelines

Proper PCB layout is extremely important in a high-current, fast-switching circuit to provide appropriate device operation and design robustness. The following circuit layout guidelines are strongly recommended.

- Place the driver device as close as possible to power and ground to minimize the length of high-current traces between the output pins and the gate of the power device.
- Place the V_{CC} bypass capacitors between the V_{CC} pin and ground as close as possible to the driver with minimal trace length to improve the noise filtering. These capacitors support the high-peak current that is drawn from the V_{CC} supply during turnon of the power MOSFET. The use of low inductance SM components such as chip resistors and chip capacitors is highly recommended.
- The turnon and turnoff current-loop paths (driver device, power MOSFET, and V_{CC} bypass capacitors) should be minimized as much as possible to keep the stray inductance to a minimum.
- Separate power traces and signal traces, such as output and input signals.
- Star-point grounding is a good way to minimize noise coupling from one current loop to another. The ground of the driver should be connected to the other circuit nodes such as the source of power switch, ground of PWM controller, and others at one single point. The connected paths should be as short as possible and as wide as possible to reduce resistance and inductance.
- Use a ground plane to provide noise shielding. Fast rise and fall times at the OUT pin can corrupt the input signals during transition. The ground plane must not be a conduction path for any current loop. Instead, the ground plane must be connected to the star-point with one single trace to establish the ground potential.
- A 1- Ω resistor may be connected between OUT pin and the gate terminal of the MOSFET to reduce gate to source voltage ringing.
- A 20- Ω resistor should be connected between VD pin and the drain terminal of the MOSFET to limit the current flowing out of VD pin when the drain terminal voltage is negative.

11.2 Layout Example

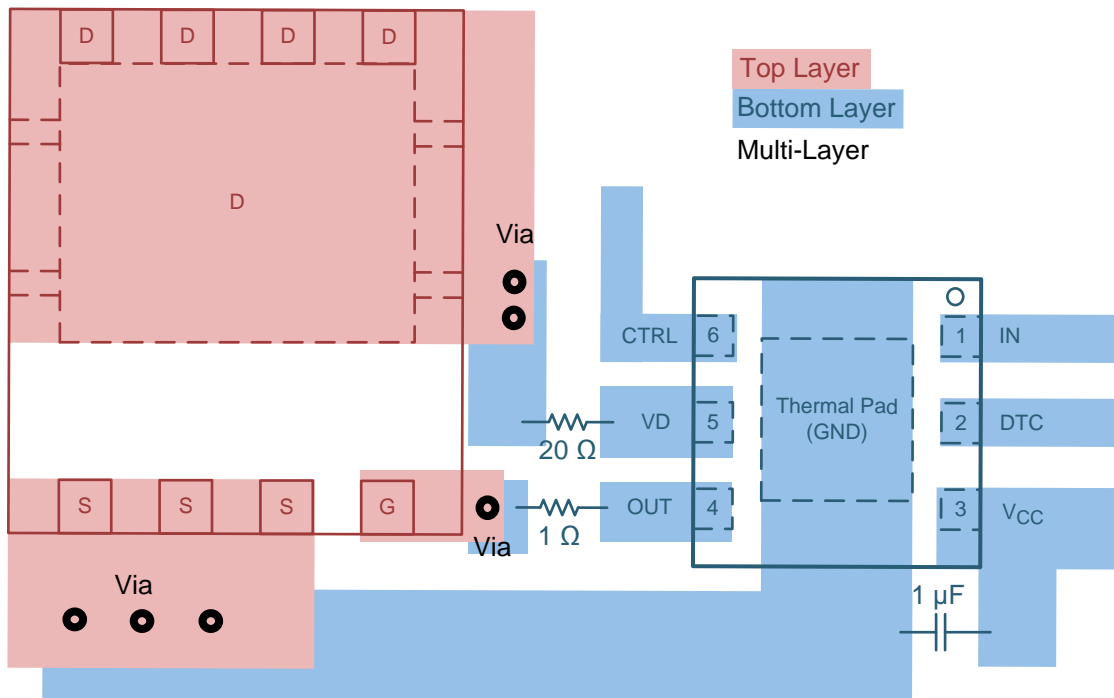

Figure 45. Layout Example With Surface-Mount MOSFET

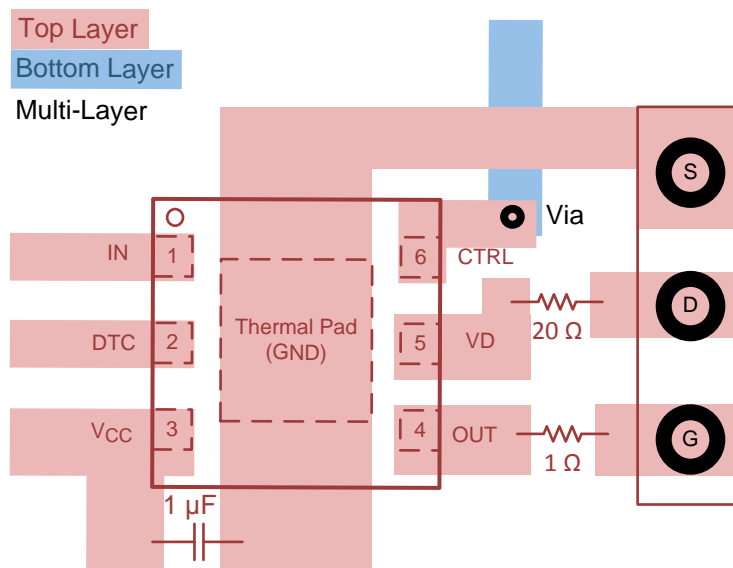

Figure 46. Layout Example With Through-Hole MOSFET

12 Device and Documentation Support

12.1 Documentation Support

12.1.1 Related Documentation

For related documentation, see the following:

- *UCD3138A Highly Integrated Digital Controller for Isolated Power*, [SLUSC66](#)
- *Using UCD7138 and UCD3138A for Advanced Synchronous Rectification Control*, [SLUA737](#)
- *UCD3138 Digital Power Peripherals Programmer's Manual*, [SLUU995](#)
- *UCD3138A Migration Guide*, [SLUA741](#)

12.2 Community Resource

The following links connect to TI community resources. Linked contents are provided "AS IS" by the respective contributors. They do not constitute TI specifications and do not necessarily reflect TI's views; see TI's [Terms of Use](#).

TI E2E™ Online Community *TI's Engineer-to-Engineer (E2E) Community*. Created to foster collaboration among engineers. At e2e.ti.com, you can ask questions, share knowledge, explore ideas and help solve problems with fellow engineers.

Design Support *TI's Design Support* Quickly find helpful E2E forums along with design support tools and contact information for technical support.

12.3 Trademarks

E2E is a trademark of Texas Instruments.
All other trademarks are the property of their respective owners.

12.4 Electrostatic Discharge Caution



These devices have limited built-in ESD protection. The leads should be shorted together or the device placed in conductive foam during storage or handling to prevent electrostatic damage to the MOS gates.

12.5 Glossary

[SLYZ022](#) — *TI Glossary*.

This glossary lists and explains terms, acronyms, and definitions.

13 Mechanical, Packaging, and Orderable Information

The following pages include mechanical, packaging, and orderable information. This information is the most current data available for the designated devices. This data is subject to change without notice and revision of this document. For browser-based versions of this data sheet, refer to the left-hand navigation.

PACKAGING INFORMATION

| Orderable Device | Status (1) | Package Type | Package Drawing | Pins | Package Qty | Eco Plan (2) | Lead/Ball Finish (6) | MSL Peak Temp (3) | Op Temp (°C) | Device Marking (4/5) | Samples |
|------------------|---------------|--------------|-----------------|------|-------------|-------------------------|-------------------------|----------------------|--------------|-------------------------|-------------------------|
| UCD7138DRSR | ACTIVE | SON | DRS | 6 | 3000 | Green (RoHS & no Sb/Br) | CU NIPDAU | Level-2-260C-1 YEAR | -40 to 125 | UD7138 | Samples |
| UCD7138DRST | ACTIVE | SON | DRS | 6 | 250 | Green (RoHS & no Sb/Br) | CU NIPDAU | Level-2-260C-1 YEAR | -40 to 125 | UD7138 | Samples |

(1) The marketing status values are defined as follows:

ACTIVE: Product device recommended for new designs.

LIFEBUY: TI has announced that the device will be discontinued, and a lifetime-buy period is in effect.

NRND: Not recommended for new designs. Device is in production to support existing customers, but TI does not recommend using this part in a new design.

PREVIEW: Device has been announced but is not in production. Samples may or may not be available.

OBSOLETE: TI has discontinued the production of the device.

(2) Eco Plan - The planned eco-friendly classification: Pb-Free (RoHS), Pb-Free (RoHS Exempt), or Green (RoHS & no Sb/Br) - please check <http://www.ti.com/productcontent> for the latest availability information and additional product content details.

TBD: The Pb-Free/Green conversion plan has not been defined.

Pb-Free (RoHS): TI's terms "Lead-Free" or "Pb-Free" mean semiconductor products that are compatible with the current RoHS requirements for all 6 substances, including the requirement that lead not exceed 0.1% by weight in homogeneous materials. Where designed to be soldered at high temperatures, TI Pb-Free products are suitable for use in specified lead-free processes.

Pb-Free (RoHS Exempt): This component has a RoHS exemption for either 1) lead-based flip-chip solder bumps used between the die and package, or 2) lead-based die adhesive used between the die and leadframe. The component is otherwise considered Pb-Free (RoHS compatible) as defined above.

Green (RoHS & no Sb/Br): TI defines "Green" to mean Pb-Free (RoHS compatible), and free of Bromine (Br) and Antimony (Sb) based flame retardants (Br or Sb do not exceed 0.1% by weight in homogeneous material)

(3) MSL, Peak Temp. - The Moisture Sensitivity Level rating according to the JEDEC industry standard classifications, and peak solder temperature.

(4) There may be additional marking, which relates to the logo, the lot trace code information, or the environmental category on the device.

(5) Multiple Device Markings will be inside parentheses. Only one Device Marking contained in parentheses and separated by a "~" will appear on a device. If a line is indented then it is a continuation of the previous line and the two combined represent the entire Device Marking for that device.

(6) Lead/Ball Finish - Orderable Devices may have multiple material finish options. Finish options are separated by a vertical ruled line. Lead/Ball Finish values may wrap to two lines if the finish value exceeds the maximum column width.

Important Information and Disclaimer: The information provided on this page represents TI's knowledge and belief as of the date that it is provided. TI bases its knowledge and belief on information provided by third parties, and makes no representation or warranty as to the accuracy of such information. Efforts are underway to better integrate information from third parties. TI has taken and continues to take reasonable steps to provide representative and accurate information but may not have conducted destructive testing or chemical analysis on incoming materials and chemicals. TI and TI suppliers consider certain information to be proprietary, and thus CAS numbers and other limited information may not be available for release.

In no event shall TI's liability arising out of such information exceed the total purchase price of the TI part(s) at issue in this document sold by TI to Customer on an annual basis.

TAPE AND REEL INFORMATION



QUADRANT ASSIGNMENTS FOR PIN 1 ORIENTATION IN TAPE



*All dimensions are nominal

| Device | Package Type | Package Drawing | Pins | SPQ | Reel Diameter (mm) | Reel Width W1 (mm) | A0 (mm) | B0 (mm) | K0 (mm) | P1 (mm) | W (mm) | Pin1 Quadrant |
|-------------|--------------|-----------------|------|------|--------------------|--------------------|---------|---------|---------|---------|--------|---------------|
| UCD7138DRSR | SON | DRS | 6 | 3000 | 330.0 | 12.4 | 3.3 | 3.3 | 1.1 | 8.0 | 12.0 | Q2 |
| UCD7138DRST | SON | DRS | 6 | 250 | 180.0 | 12.4 | 3.3 | 3.3 | 1.1 | 8.0 | 12.0 | Q2 |

TAPE AND REEL BOX DIMENSIONS

*All dimensions are nominal

| Device | Package Type | Package Drawing | Pins | SPQ | Length (mm) | Width (mm) | Height (mm) |
|-------------|--------------|-----------------|------|------|-------------|------------|-------------|
| UCD7138DRSR | SON | DRS | 6 | 3000 | 367.0 | 367.0 | 35.0 |
| UCD7138DRST | SON | DRS | 6 | 250 | 210.0 | 185.0 | 35.0 |

DRS (S-PWSON-N6)

PLASTIC SMALL OUTLINE NO-LEAD

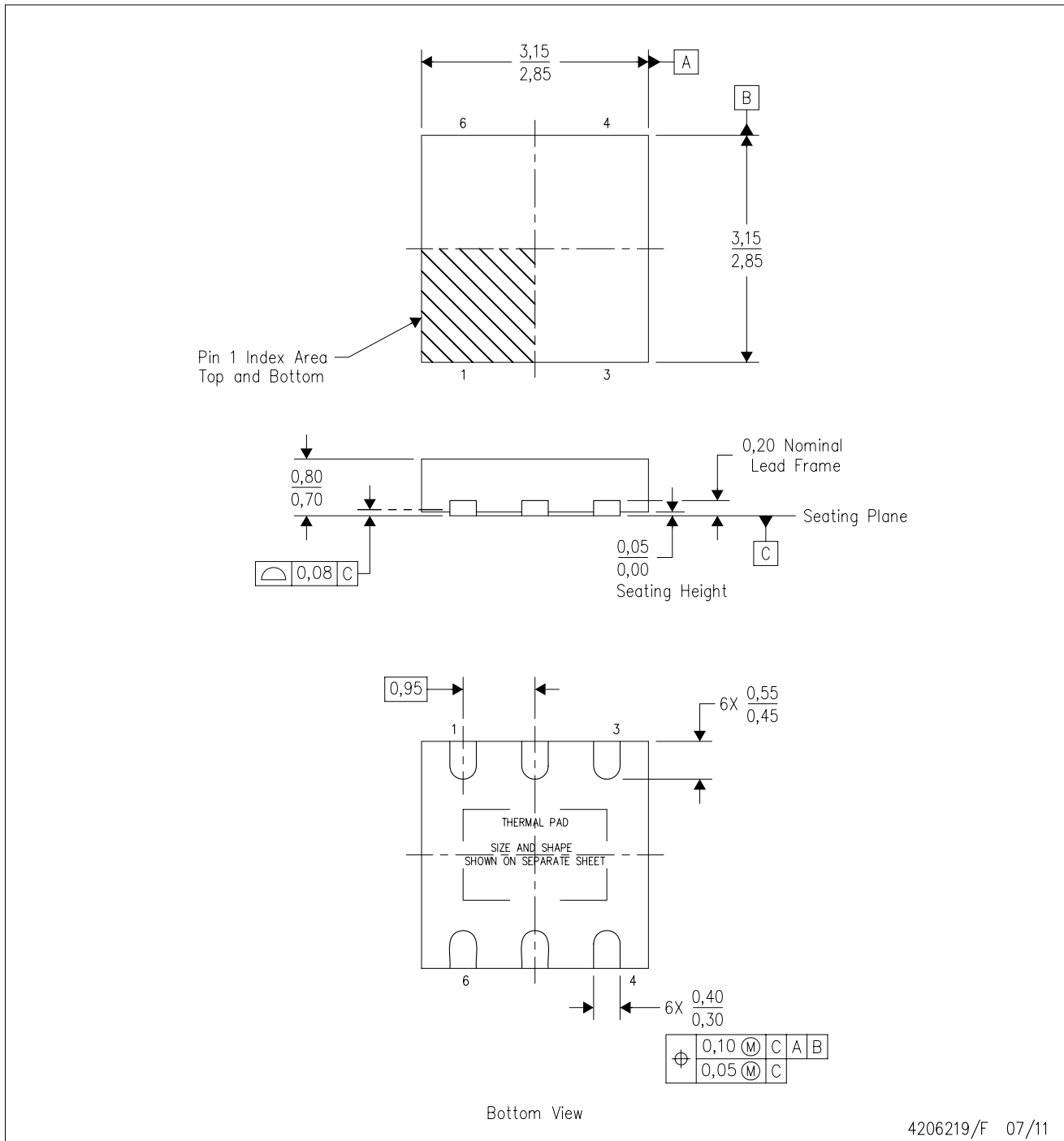

- NOTES:
- All linear dimensions are in millimeters. Dimensioning and tolerancing per ASME Y14.5M-1994.
 - This drawing is subject to change without notice.
 - SON (Small Outline No-Lead) package configuration.
 - The package thermal pad must be soldered to the board for thermal and mechanical performance.
 - See the additional figure in the Product Data Sheet for details regarding the exposed thermal pad features and dimensions.

THERMAL PAD MECHANICAL DATA

DRS (S-PWSON-N6)

PLASTIC SMALL OUTLINE NO-LEAD

THERMAL INFORMATION

This package incorporates an exposed thermal pad that is designed to be attached directly to an external heatsink. The thermal pad must be soldered directly to the printed circuit board (PCB). After soldering, the PCB can be used as a heatsink. In addition, through the use of thermal vias, the thermal pad can be attached directly to the appropriate copper plane shown in the electrical schematic for the device, or alternatively, can be attached to a special heatsink structure designed into the PCB. This design optimizes the heat transfer from the integrated circuit (IC).

For information on the Quad Flatpack No-Lead (QFN) package and its advantages, refer to Application Report, QFN/SON PCB Attachment, Texas Instruments Literature No. SLUA271. This document is available at www.ti.com.

The exposed thermal pad dimensions for this package are shown in the following illustration.

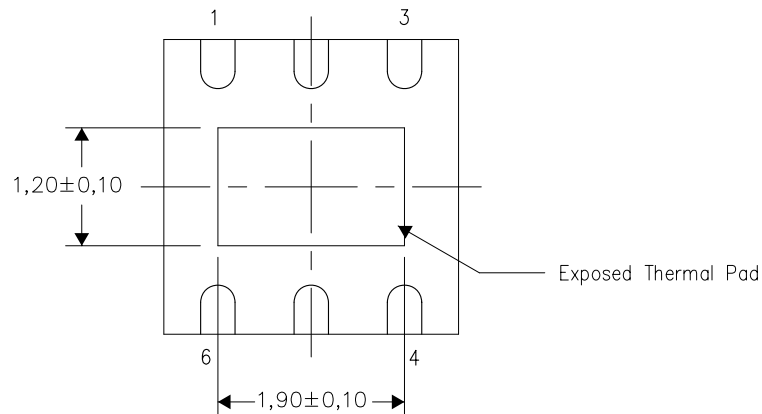

Bottom View

Exposed Thermal Pad Dimensions

4207663/E 07/11

NOTE: All linear dimensions are in millimeters

DRS (S-PWSON-N6)

PLASTIC SMALL OUTLINE NO-LEAD

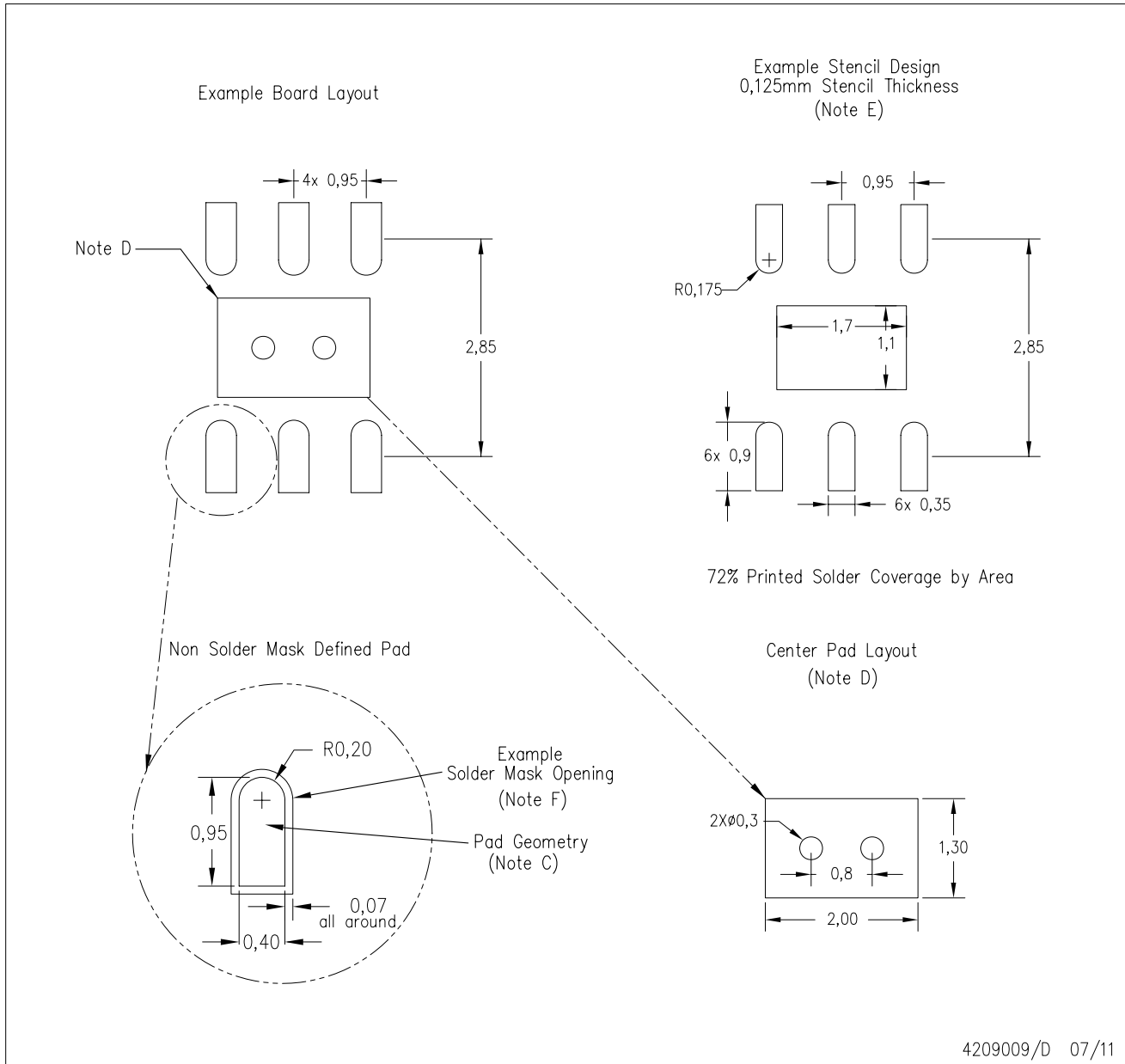

- NOTES:
- A. All linear dimensions are in millimeters.
 - B. This drawing is subject to change without notice.
 - C. Publication IPC-7351 is recommended for alternate designs.
 - D. This package is designed to be soldered to a thermal pad on the board. Refer to Application Note, QFN/SON PCB Attachment, Texas Instruments Literature No. SLUA271, and also the Product Data Sheets for specific thermal information, via requirements, and recommended board layout. These documents are available at www.ti.com <<http://www.ti.com>>.
 - E. Laser cutting apertures with trapezoidal walls and also rounding corners will offer better paste release. Customers should contact their board assembly site for stencil design recommendations. Refer to IPC 7525 for stencil design considerations.
 - F. Customers should contact their board fabrication site for solder mask tolerances.

IMPORTANT NOTICE AND DISCLAIMER

TI PROVIDES TECHNICAL AND RELIABILITY DATA (INCLUDING DATASHEETS), DESIGN RESOURCES (INCLUDING REFERENCE DESIGNS), APPLICATION OR OTHER DESIGN ADVICE, WEB TOOLS, SAFETY INFORMATION, AND OTHER RESOURCES "AS IS" AND WITH ALL FAULTS, AND DISCLAIMS ALL WARRANTIES, EXPRESS AND IMPLIED, INCLUDING WITHOUT LIMITATION ANY IMPLIED WARRANTIES OF MERCHANTABILITY, FITNESS FOR A PARTICULAR PURPOSE OR NON-INFRINGEMENT OF THIRD PARTY INTELLECTUAL PROPERTY RIGHTS.

These resources are intended for skilled developers designing with TI products. You are solely responsible for (1) selecting the appropriate TI products for your application, (2) designing, validating and testing your application, and (3) ensuring your application meets applicable standards, and any other safety, security, or other requirements. These resources are subject to change without notice. TI grants you permission to use these resources only for development of an application that uses the TI products described in the resource. Other reproduction and display of these resources is prohibited. No license is granted to any other TI intellectual property right or to any third party intellectual property right. TI disclaims responsibility for, and you will fully indemnify TI and its representatives against, any claims, damages, costs, losses, and liabilities arising out of your use of these resources.

TI's products are provided subject to TI's Terms of Sale (www.ti.com/legal/termsofsale.html) or other applicable terms available either on ti.com or provided in conjunction with such TI products. TI's provision of these resources does not expand or otherwise alter TI's applicable warranties or warranty disclaimers for TI products.

Mailing Address: Texas Instruments, Post Office Box 655303, Dallas, Texas 75265
Copyright © 2019, Texas Instruments Incorporated

Looking for pricing, stock, or lifecycle information?

Click below to explore more details on WIN SOURCE:

 [View UCD7138DRST](#) on WIN SOURCE

 [Texas Instruments](#) Information

Optimize Your Supply Chain with WIN SOURCE Solutions

-  Global Sourcing Solution
-  Obsolete Management
-  Cost Control Management
-  Shortage Management
-  Alternative Solution
-  Excess Inventory Management