



**THE DATASHEET OF
TRF37C73IDSGT**



TRF37C73 1-6000 MHz RF Gain Block

1 Features

- 1 MHz – 6000 MHz
- Gain: 17 dB
- Noise Figure: 3.5 dB
- Output P1dB: 16.5 dBm at 2000 MHz
- Output IP3: 28.5 dBm at 2000 MHz
- Power Down Mode
- Single Supply: 3.3 V
- Stabilized Performance Over Temperature
- Unconditionally Stable
- Robust ESD: >1 kV HBM; >1 kV CDM

2 Applications

- General Purpose RF Gain Block
- Consumer
- Industrial
- Utility Meters
- Low-cost Radios
- Cellular Base Station
- Wireless Infrastructure
- RF Backhaul
- Radar
- Electronic Warfare
- Software-defined Radio
- Test and Measurement
- Point-to-Point/Multipoint Microwave
- Software Defined Radios
- RF Repeaters
- Distributed Antenna Systems
- LO and PA Driver Amplifier
- Wireless Data, Satellite, DBS, CATV
- IF Amplifier

3 Description

The TRF37C73 is packaged in a 2.00mm x 2.00mm WSON with a power down pin feature making it ideal for applications where space and low power modes are critical.

The TRF37C73 is designed for ease of use. For maximum flexibility, this family of parts uses a common 3.3 V supply and consumes 55 mA. In addition, this family was designed with an active bias circuit that provides a stable and predictable bias current over process, temperature and voltage variations. For gain and linearity budgets the device was designed to provide a flat gain response and excellent OIP3 out to 6000 MHz. For space constrained applications, this family is internally matched to 50 Ω , which simplifies ease of use and minimizes needed PCB area.

Device Information⁽¹⁾

PART NUMBER	PACKAGE	BODY SIZE (NOM)
TRF37C73	WSON (32)	2.00mm x 2.00mm

(1) For all available packages, see the orderable addendum at the end of the datasheet.

Simplified Schematic

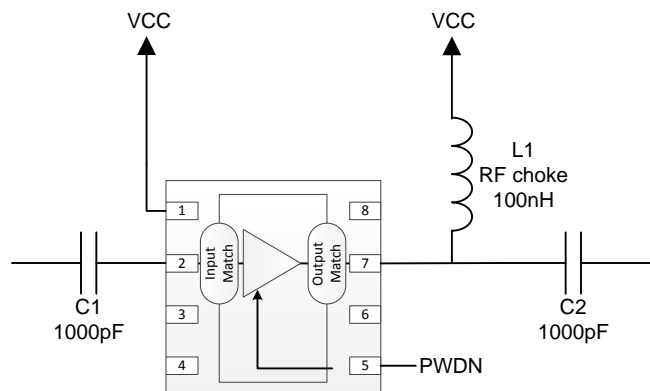

Table of Contents

1 Features	1	7.2 Functional Block Diagram	8
2 Applications	1	7.3 Feature Description.....	8
3 Description	1	7.4 Device Functional Modes.....	8
4 Revision History	2	8 Applications and Implementation	9
5 Pin Configuration and Functions	3	8.1 Application Information.....	9
6 Specifications	4	8.2 Typical Application	9
6.1 Absolute Maximum Ratings	4	9 Power Supply Recommendations	10
6.2 Handling Ratings.....	4	10 Layout	11
6.3 Recommended Operating Conditions.....	4	10.1 Layout Guidelines	11
6.4 Thermal Information	4	10.2 Layout Example	11
6.5 Electrical Characteristics.....	5	11 Device and Documentation Support	12
6.6 Timing Requirements	5	11.1 Trademarks	12
6.7 Typical Characteristics	6	11.2 Electrostatic Discharge Caution.....	12
7 Detailed Description	8	11.3 Glossary	12
7.1 Overview	8	12 Mechanical, Packaging, and Orderable Information	12

4 Revision History

DATE	REVISION	NOTES
May 2014	*	Initial release.

5 Pin Configuration and Functions

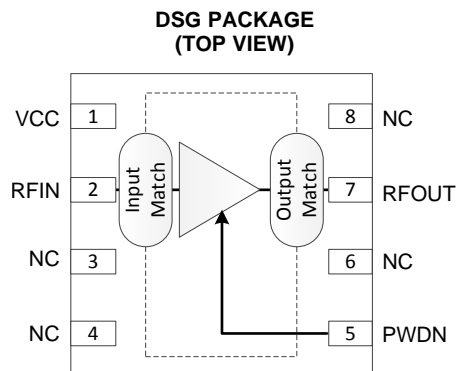

Pin Functions

PIN		DESCRIPTION
NAME	NO.	
VCC	1	DC Bias.
RFIN	2	RF input. Connect to an RF source through a DC-blocking capacitor. Internally matched to 50 Ω.
NC	3, 4, 6, 8	No electrical connection. Connect pad to GND for board level reliability integrity.
PWDN	5	When high the device is in power down state. When LOW or NC the device is in active state. Internal pulldown resistor to GND.
RFOUT	7	RF Output and DC Bias (V_{CC}). Connect to DC supply through an RF choke inductor. Connect to output load through a DC-blocking capacitor. Internally matched to 50 Ω.
GND	PowerPAD™	RF and DC GND. Connect to PCB ground plane.

6 Specifications

6.1 Absolute Maximum Ratings

over operating free-air temperature range (unless otherwise noted) ⁽¹⁾

	MIN	MAX	UNIT
Supply Input voltage	-0.3	3.6	V
Input Power		10	dBm
Operating virtual junction temperature range	-40	150	°C

- (1) Stresses beyond those listed under *Absolute Maximum Ratings* may cause permanent damage to the device. These are stress ratings only, which do not imply functional operation of the device at these or any other conditions beyond those indicated under *Recommended Operating Conditions*. Exposure to absolute-maximum-rated conditions for extended periods may affect device reliability.

6.2 Handling Ratings

		MIN	MAX	UNIT	
T _{STG}	Storage temperature range	-65	150	°C	
V _{ESD}	Electrostatic discharge	Human body model (HBM), per ANSI/ESDA/JEDEC JS-001, all pins ⁽¹⁾	-1	1	kV
		Charged device model (CDM), per JEDEC specification JESD22-C101, all pins ⁽²⁾	-1	1	kV

- (1) JEDEC document JEP155 states that 500-V HBM allows safe manufacturing with a standard ESD control process.
 (2) JEDEC document JEP157 states that 250-V CDM allows safe manufacturing with a standard ESD control process.

6.3 Recommended Operating Conditions

over operating free-air temperature range (unless otherwise noted)

	MIN	NOM	MAX	UNIT
Supply Voltage, V _{CC}	3	3.3	3.45	V
Operating junction temperature, T _J	-40		125	°C

6.4 Thermal Information

THERMAL METRIC ⁽¹⁾		DSG	UNIT
		8 PINS	
R _{θJA}	Junction-to-ambient thermal resistance	79.3	°C/W
R _{θJctop}	Junction-to-case (top) thermal resistance	110	
R _{θJB}	Junction-to-board thermal resistance	49	
ψ _{JT}	Junction-to-top characterization parameter	6	
ψ _{JB}	Junction-to-board characterization parameter	49.4	
R _{θJcbot}	Junction-to-case (bottom) thermal resistance	19.2	

- (1) For more information about traditional and new thermal metrics, see the *IC Package Thermal Metrics* application report, [SPRA953](#).

6.5 Electrical Characteristics

 $V_{CC} = 3V3$, $T_A = 25^\circ C$, $PW_{DN} = Low$, $L_{OUT} = 100\text{ nH}$, $C1 = C2 = 1000\text{ pF}$, $Z_S = Z_L = 50\ \Omega$ (unless otherwise noted)

PARAMETER		TEST CONDITIONS	MIN	TYP	MAX	UNIT
DC PARAMETERS						
I_{CC}	Total supply current			55	65	mA
	Power down current	$PW_{DN} = High$		125		μA
P_{diss}	Power dissipation		0.182			W
RF FREQUENCY RANGE						
	Frequency range		1		6000	MHz
G	Small signal gain	$f_{RF} = 400\text{ MHz}$		18.5		dB
		$f_{RF} = 2000\text{ MHz}$		17.5		dB
		$f_{RF} = 3000\text{ MHz}$		16.5		dB
		$f_{RF} = 4000\text{ MHz}$		15		dB
		$f_{RF} = 5000\text{ MHz}$		13		dB
		$f_{RF} = 6000\text{ MHz}$		11		dB
OP1dB	Output 1dB compression point	At 2000 MHz		16.5		dBm
OIP3	Output 3rd order intercept point	At 2000 MHz, 2-tone 10 MHz apart		28.5		dBm
NF	Noise figure	At 2000 MHz		3.5		dB
$R_{(LI)}$	Input return loss	At 2000 MHz		19		dB
$R_{(LO)}$	Output return loss	At 2000 MHz		13		dB
PW_{DN} PIN						
V_{IH}	High level input level		2			V
V_{IL}	Low level input level				0.8	V
I_{IH}	High level input current			30		μA
I_{IL}	Low level input current			1		μA

6.6 Timing Requirements

			MIN	TYP	MAX	UNIT
PW_{DN} PIN						
t_{ON}	Turn-on Time	50% TTL to 90% P_{OUT}		0.6		μs
t_{OFF}	Turn-off Time	50% TTL to 10% P_{OUT}		1.4		μs

6.7 Typical Characteristics

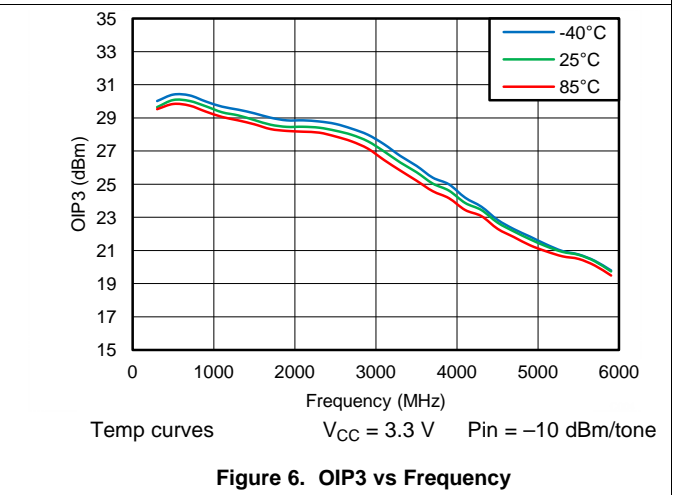
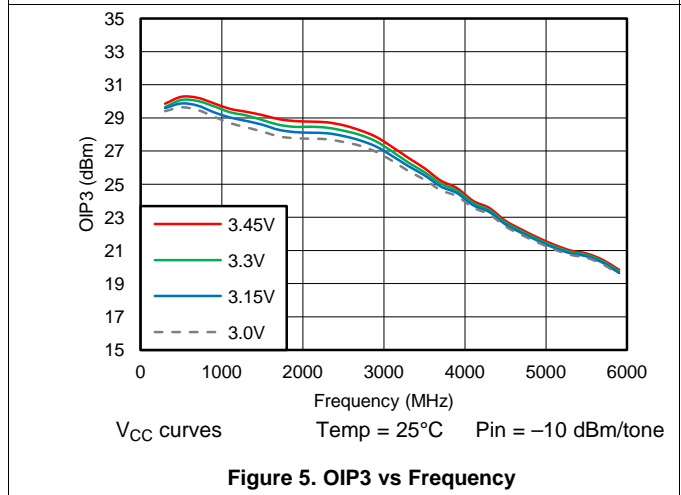
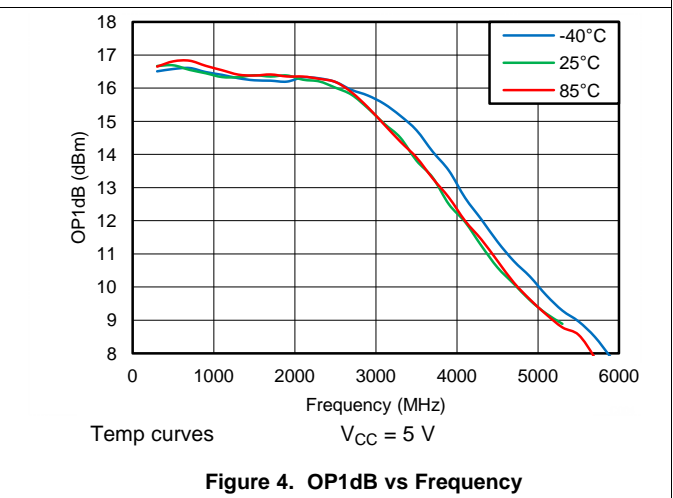
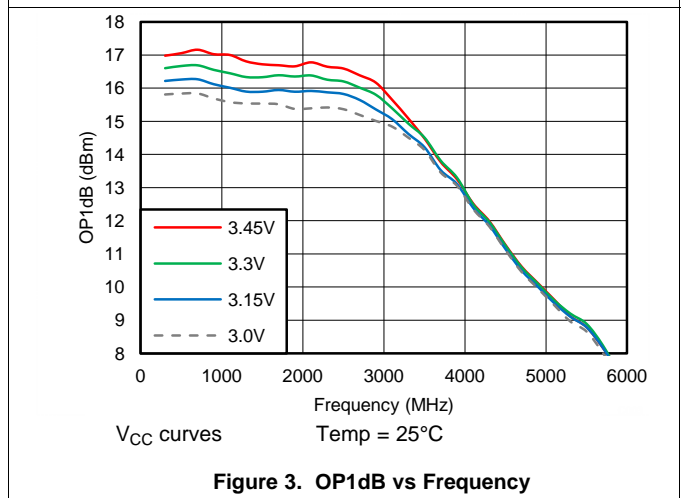
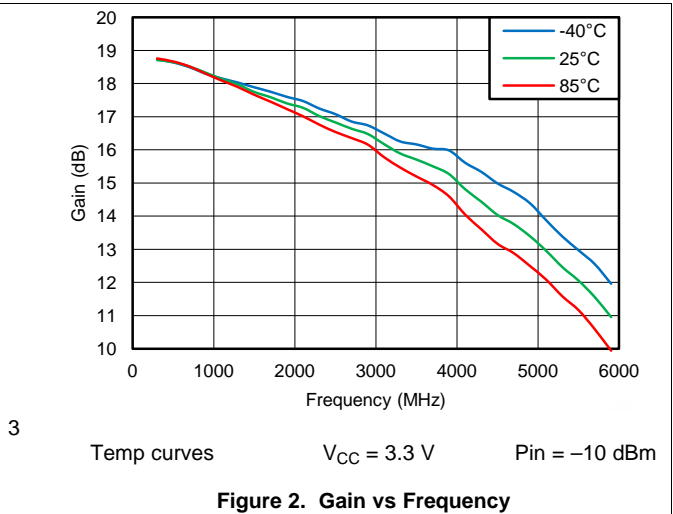
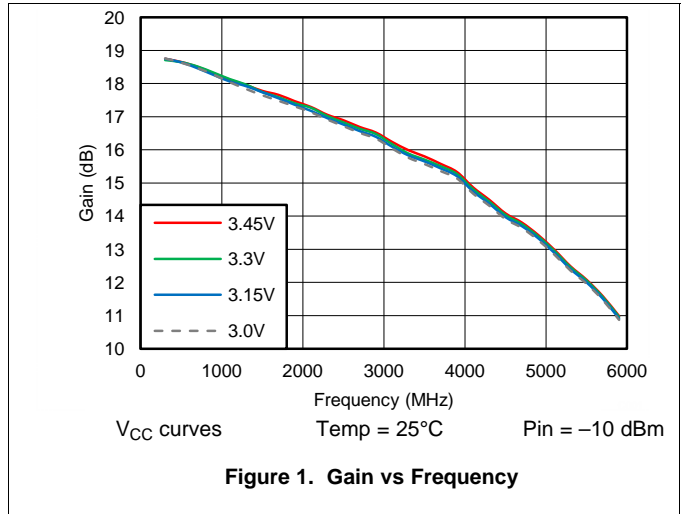

Typical Characteristics (continued)

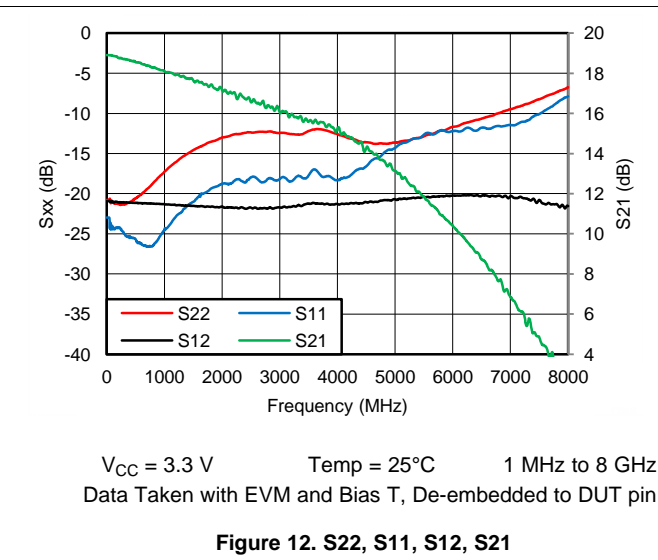
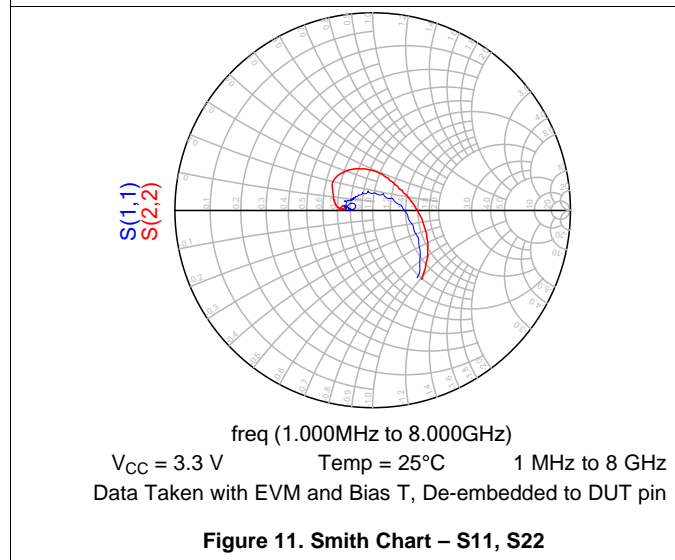
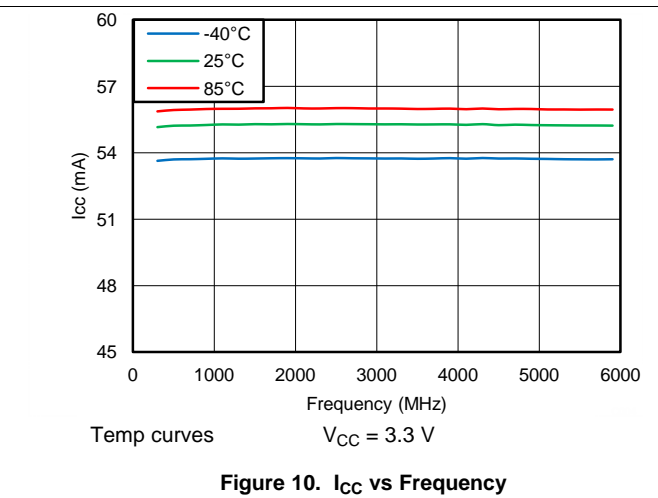
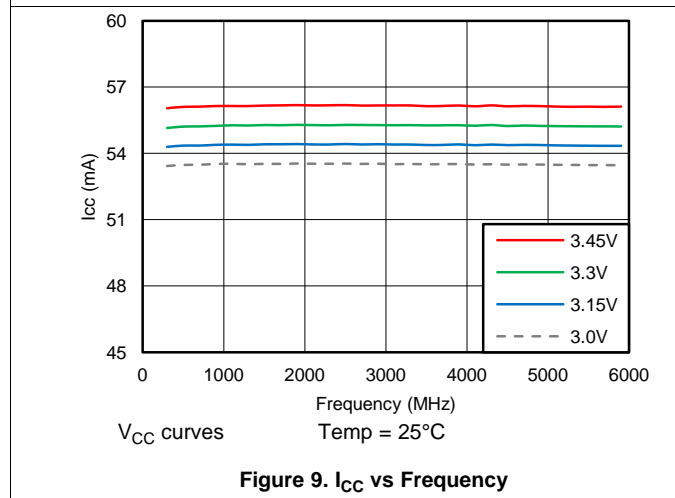
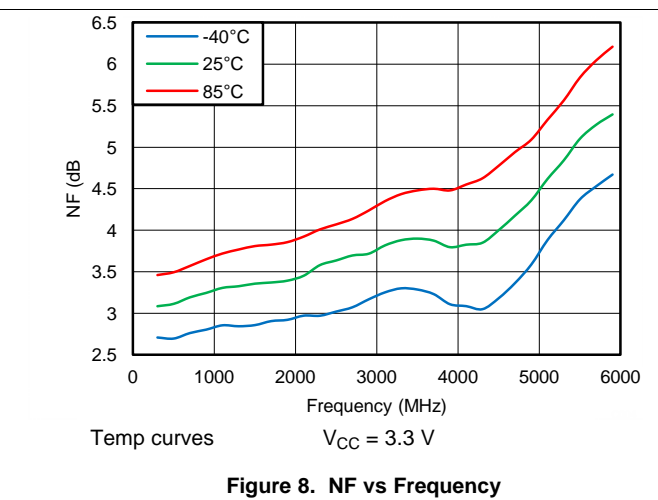
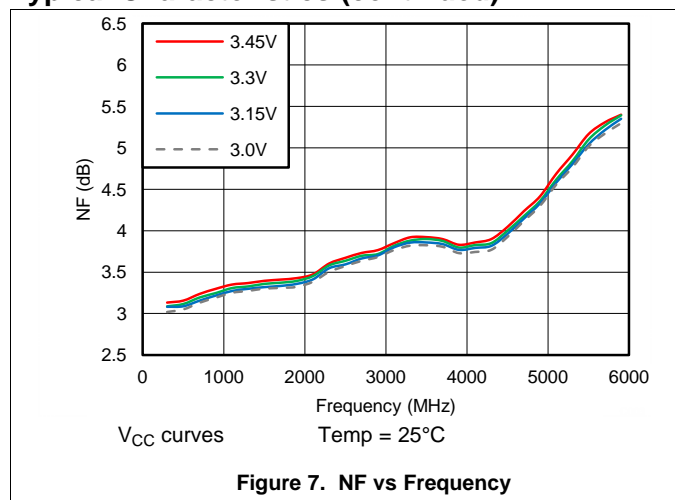

7 Detailed Description

7.1 Overview

The device is a 3.3 V general purpose RF gain block. It is a SiGe Darlington amplifier with integrated 50 Ω input and output matching. The device contains an active bias circuit to maintain performance over a wide temperature and voltage range. The included power down function allows the amplifier to shut down saving power when the amplifier is not needed. Fast shut down and start up enable the amplifier to be used in a host of time division duplex applications.

7.2 Functional Block Diagram

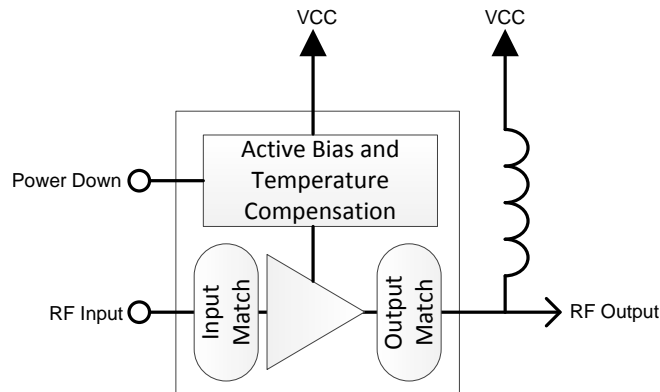

7.3 Feature Description

The TRF37C73 is a fixed gain RF amplifier. It is internally matched to 50 Ω on both the input and output. It is a fully cascadable general purpose amplifier. The included active bias circuitry ensures the amplifier performance is optimized over the full operating temperature and voltage ranges.

7.4 Device Functional Modes

7.4.1 Power Down

The TRF37C73 PWDN pin can be left unconnected for normal operation or a logic-high for disable mode operation. For applications that use the power down mode, normal 5 V TLL levels are supported.

8 Applications and Implementation

8.1 Application Information

The TRF37C73 is a wideband, high performance, general purpose RF amplifier. To maximize its performance, good RF layout and grounding techniques should be employed.

8.2 Typical Application

The TRF37C73 device is typically placed in a system as illustrated in [Figure 13](#).

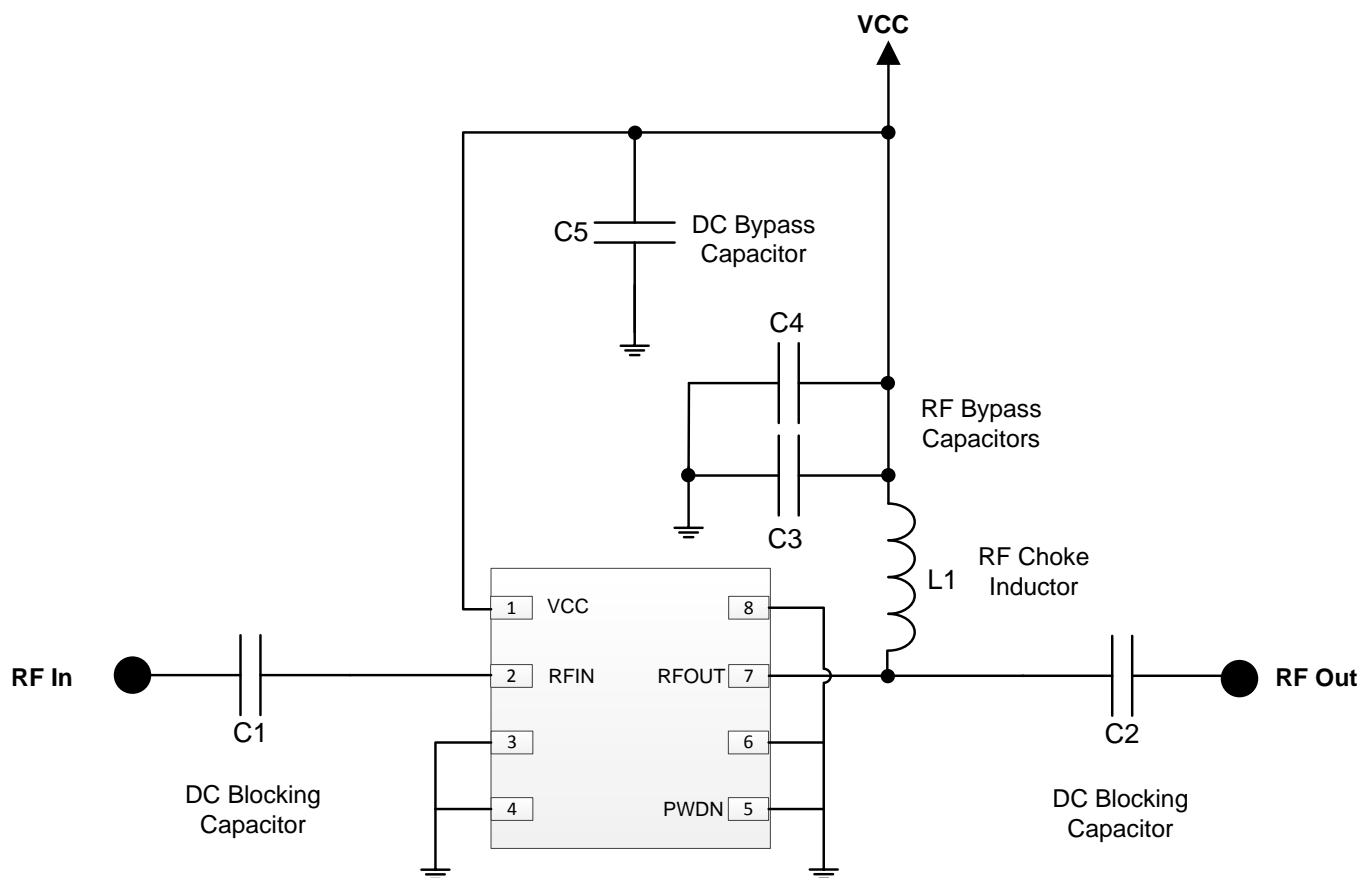

Figure 13. Typical Application Schematic for TRF37C73

8.2.1 Design Requirements

Table 1. Design Parameters

PARAMETERS	EXAMPLE VALUES
Input power range	< 3 dBm
Output power	< 18 dBm
Operating frequency range	1 — 6000 MHz

8.2.2 Detailed Design Procedure

The TRF37C73 is a simple to use internally matched and cascadable RF amplifier. Following the recommended RF layout with good quality RF components and local DC bypass capacitors will ensure optimal performance is achieved. TI provides various support materials including S-Parameter and ADS models to allow the design to be optimized to the user's particular performance needs.

8.2.3 Application Curve

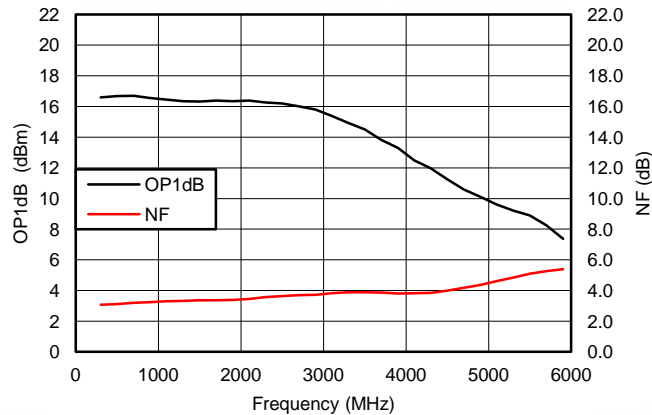

Figure 14. OP1dB and NF vs Frequency

9 Power Supply Recommendations

All supplies may be generated from a common nominal 3.3 V source but should be isolated through decoupling capacitors placed close to the device. The typical application schematic in [Figure 13](#) is an excellent example. Select capacitors with self-resonant frequency near the application frequency. When multiple capacitors are used in parallel to create a broadband decoupling network, place the capacitor with the higher self-resonant frequency closer to the device. Expensive tantalum capacitors are not needed for optimal performance.

10 Layout

10.1 Layout Guidelines

Good layout practice helps to enable excellent linearity and isolation performance. An example of good layout is shown in Figure 15. In the example, only the top signal layer and its adjacent ground reference plane are shown.

- Excellent electrical connection from the PowerPAD™ to the board ground is essential. Use the recommended footprint, solder the pad to the board, and do not include solder mask under the pad.
- Connect pad ground to device terminal ground on the top board layer.
- Verify that the return DC and RF current path have a low impedance ground plane directly under the package and RF signal traces into and out of the amplifier.
- Ensure that ground planes on the top and any internal layers are well stitched with vias.
- Do not route RF signal lines over breaks in the reference ground plane.
- Avoid routing clocks and digital control lines near RF signal lines.
- Do not route RF or DC signal lines over noisy power planes. Ground is the best reference, although clean power planes can serve where necessary.
- Place supply decoupling close to the device.

10.2 Layout Example

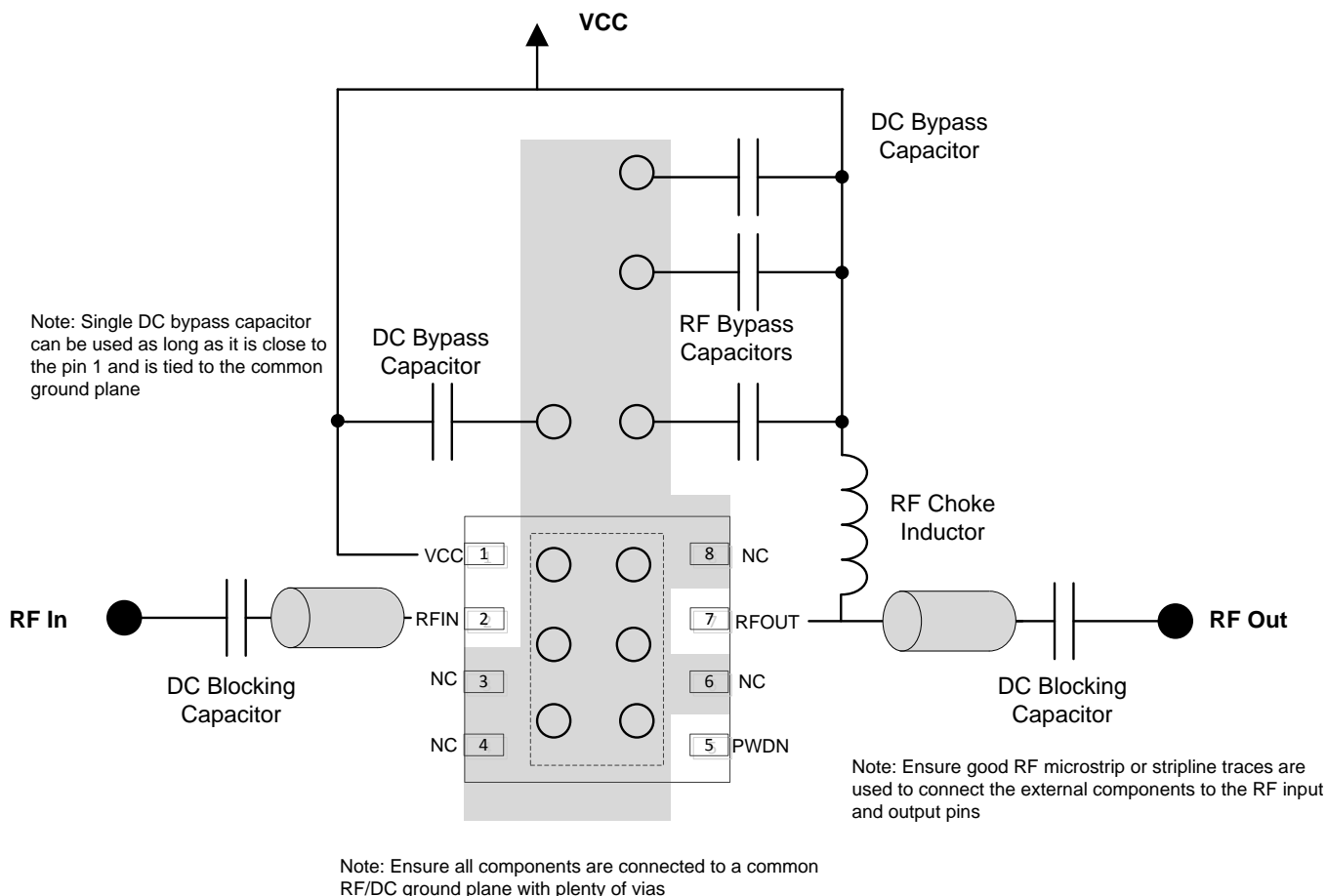

Figure 15. Layout

11 Device and Documentation Support

11.1 Trademarks

PowerPAD is a trademark of Texas Instruments.

11.2 Electrostatic Discharge Caution



These devices have limited built-in ESD protection. The leads should be shorted together or the device placed in conductive foam during storage or handling to prevent electrostatic damage to the MOS gates.

11.3 Glossary

[SLYZ022](#) — *TI Glossary*.

This glossary lists and explains terms, acronyms and definitions.

12 Mechanical, Packaging, and Orderable Information

The following pages include mechanical packaging and orderable information. This information is the most current data available for the designated devices. This data is subject to change without notice and revision of this document. For browser-based versions of this data sheet, refer to the left-hand navigation.

PACKAGING INFORMATION

Orderable Device	Status (1)	Package Type	Package Drawing	Pins	Package Qty	Eco Plan (2)	Lead/Ball Finish (6)	MSL Peak Temp (3)	Op Temp (°C)	Device Marking (4/5)	Samples
TRF37C73IDSGR	ACTIVE	WSON	DSG	8	3000	Green (RoHS & no Sb/Br)	CU NIPDAU	Level-2-260C-1 YEAR	-40 to 85	C73I	Samples
TRF37C73IDSGT	ACTIVE	WSON	DSG	8	250	Green (RoHS & no Sb/Br)	CU NIPDAU	Level-2-260C-1 YEAR	-40 to 85	C73I	Samples

(1) The marketing status values are defined as follows:

ACTIVE: Product device recommended for new designs.

LIFEBUY: TI has announced that the device will be discontinued, and a lifetime-buy period is in effect.

NRND: Not recommended for new designs. Device is in production to support existing customers, but TI does not recommend using this part in a new design.

PREVIEW: Device has been announced but is not in production. Samples may or may not be available.

OBSELETE: TI has discontinued the production of the device.

(2) Eco Plan - The planned eco-friendly classification: Pb-Free (RoHS), Pb-Free (RoHS Exempt), or Green (RoHS & no Sb/Br) - please check <http://www.ti.com/productcontent> for the latest availability information and additional product content details.

TBD: The Pb-Free/Green conversion plan has not been defined.

Pb-Free (RoHS): TI's terms "Lead-Free" or "Pb-Free" mean semiconductor products that are compatible with the current RoHS requirements for all 6 substances, including the requirement that lead not exceed 0.1% by weight in homogeneous materials. Where designed to be soldered at high temperatures, TI Pb-Free products are suitable for use in specified lead-free processes.

Pb-Free (RoHS Exempt): This component has a RoHS exemption for either 1) lead-based flip-chip solder bumps used between the die and package, or 2) lead-based die adhesive used between the die and leadframe. The component is otherwise considered Pb-Free (RoHS compatible) as defined above.

Green (RoHS & no Sb/Br): TI defines "Green" to mean Pb-Free (RoHS compatible), and free of Bromine (Br) and Antimony (Sb) based flame retardants (Br or Sb do not exceed 0.1% by weight in homogeneous material)

(3) MSL, Peak Temp. - The Moisture Sensitivity Level rating according to the JEDEC industry standard classifications, and peak solder temperature.

(4) There may be additional marking, which relates to the logo, the lot trace code information, or the environmental category on the device.

(5) Multiple Device Markings will be inside parentheses. Only one Device Marking contained in parentheses and separated by a "~" will appear on a device. If a line is indented then it is a continuation of the previous line and the two combined represent the entire Device Marking for that device.

(6) Lead/Ball Finish - Orderable Devices may have multiple material finish options. Finish options are separated by a vertical ruled line. Lead/Ball Finish values may wrap to two lines if the finish value exceeds the maximum column width.

Important Information and Disclaimer: The information provided on this page represents TI's knowledge and belief as of the date that it is provided. TI bases its knowledge and belief on information provided by third parties, and makes no representation or warranty as to the accuracy of such information. Efforts are underway to better integrate information from third parties. TI has taken and continues to take reasonable steps to provide representative and accurate information but may not have conducted destructive testing or chemical analysis on incoming materials and chemicals. TI and TI suppliers consider certain information to be proprietary, and thus CAS numbers and other limited information may not be available for release.

In no event shall TI's liability arising out of such information exceed the total purchase price of the TI part(s) at issue in this document sold by TI to Customer on an annual basis.

TAPE AND REEL INFORMATION

QUADRANT ASSIGNMENTS FOR PIN 1 ORIENTATION IN TAPE

*All dimensions are nominal

Device	Package Type	Package Drawing	Pins	SPQ	Reel Diameter (mm)	Reel Width W1 (mm)	A0 (mm)	B0 (mm)	K0 (mm)	P1 (mm)	W (mm)	Pin1 Quadrant
TRF37C73IDSGR	WSON	DSG	8	3000	180.0	8.4	2.3	2.3	1.15	4.0	8.0	Q2
TRF37C73IDSGT	WSON	DSG	8	250	180.0	8.4	2.3	2.3	1.15	4.0	8.0	Q2

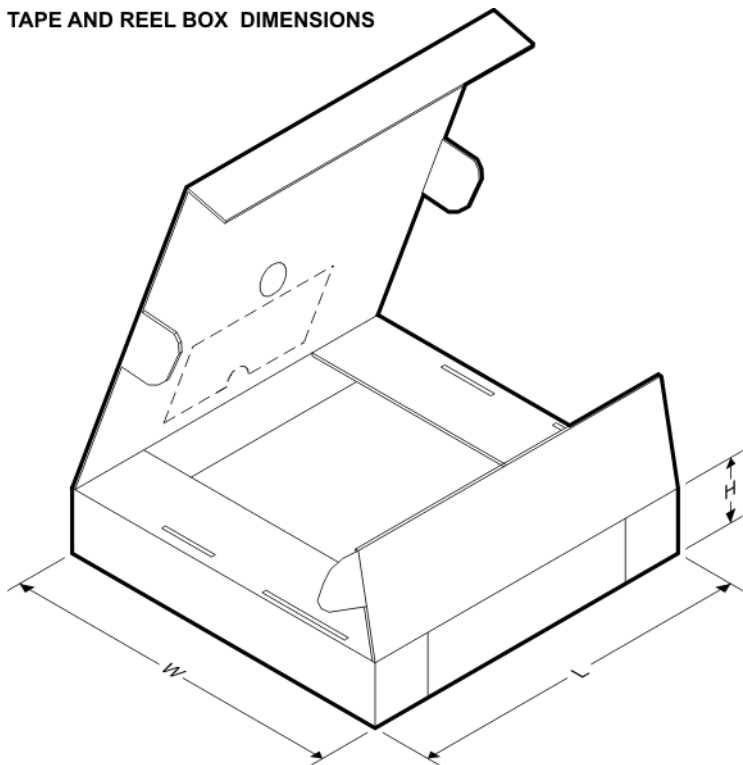
TAPE AND REEL BOX DIMENSIONS

*All dimensions are nominal

Device	Package Type	Package Drawing	Pins	SPQ	Length (mm)	Width (mm)	Height (mm)
TRF37C73IDSGR	WSON	DSG	8	3000	210.0	185.0	35.0
TRF37C73IDSGT	WSON	DSG	8	250	210.0	185.0	35.0

GENERIC PACKAGE VIEW

DSG 8

WSON - 0.8 mm max height

2 x 2, 0.5 mm pitch

PLASTIC SMALL OUTLINE - NO LEAD

This image is a representation of the package family, actual package may vary.
Refer to the product data sheet for package details.

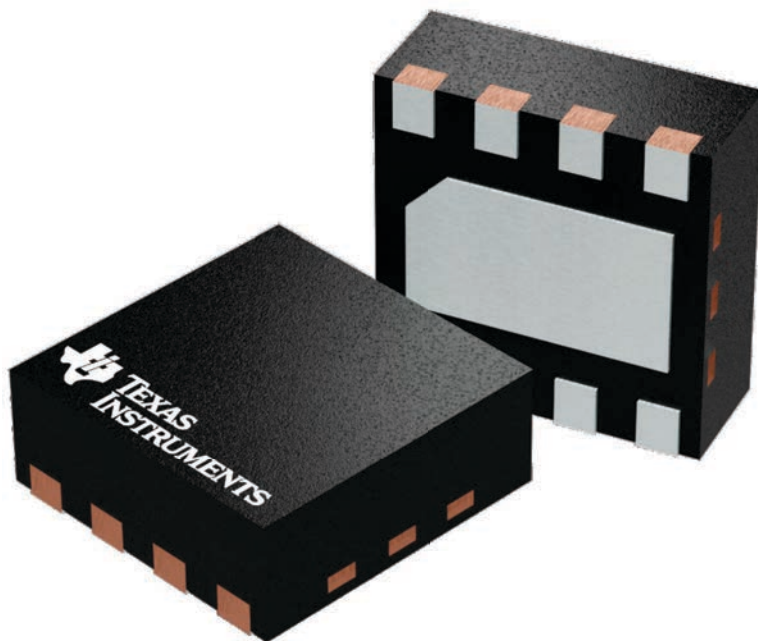

4224783/A

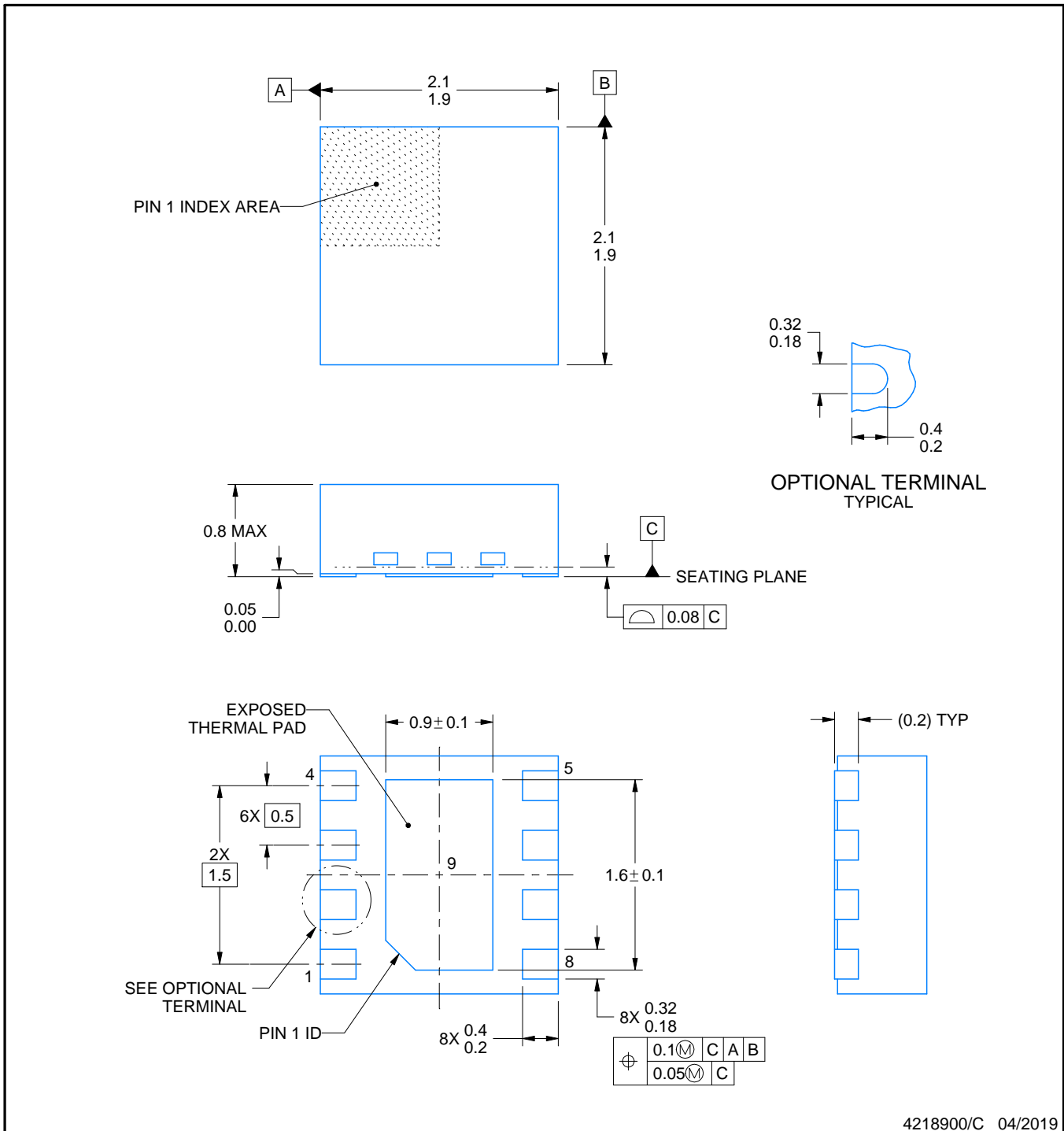
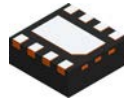

4218900/C 04/2019

NOTES:

1. All linear dimensions are in millimeters. Any dimensions in parenthesis are for reference only. Dimensioning and tolerancing per ASME Y14.5M.
2. This drawing is subject to change without notice.
3. The package thermal pad must be soldered to the printed circuit board for thermal and mechanical performance.

EXAMPLE BOARD LAYOUT

DSG0008A

WSON - 0.8 mm max height

PLASTIC SMALL OUTLINE - NO LEAD

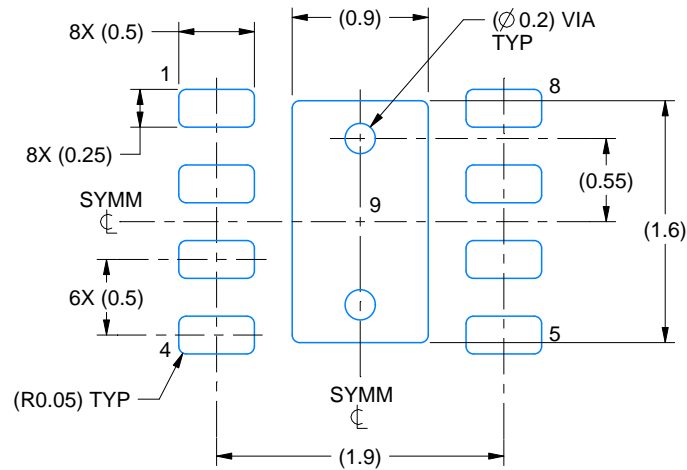

LAND PATTERN EXAMPLE
SCALE:20X

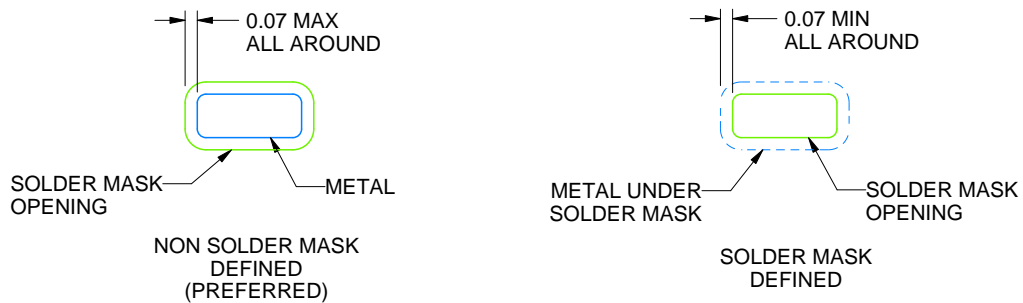

SOLDER MASK DETAILS

4218900/C 04/2019

NOTES: (continued)

4. This package is designed to be soldered to a thermal pad on the board. For more information, see Texas Instruments literature number SLUA271 (www.ti.com/lit/slua271).
5. Vias are optional depending on application, refer to device data sheet. If any vias are implemented, refer to their locations shown on this view. It is recommended that vias under paste be filled, plugged or tented.

EXAMPLE STENCIL DESIGN

DSG0008A

WSON - 0.8 mm max height

PLASTIC SMALL OUTLINE - NO LEAD

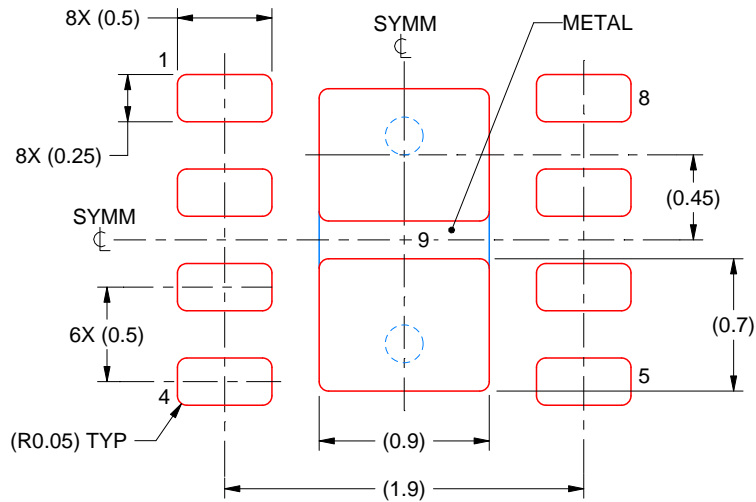

SOLDER PASTE EXAMPLE
BASED ON 0.125 mm THICK STENCIL

EXPOSED PAD 9:
87% PRINTED SOLDER COVERAGE BY AREA UNDER PACKAGE
SCALE:25X

4218900/C 04/2019

NOTES: (continued)

6. Laser cutting apertures with trapezoidal walls and rounded corners may offer better paste release. IPC-7525 may have alternate design recommendations.

IMPORTANT NOTICE AND DISCLAIMER

TI PROVIDES TECHNICAL AND RELIABILITY DATA (INCLUDING DATASHEETS), DESIGN RESOURCES (INCLUDING REFERENCE DESIGNS), APPLICATION OR OTHER DESIGN ADVICE, WEB TOOLS, SAFETY INFORMATION, AND OTHER RESOURCES "AS IS" AND WITH ALL FAULTS, AND DISCLAIMS ALL WARRANTIES, EXPRESS AND IMPLIED, INCLUDING WITHOUT LIMITATION ANY IMPLIED WARRANTIES OF MERCHANTABILITY, FITNESS FOR A PARTICULAR PURPOSE OR NON-INFRINGEMENT OF THIRD PARTY INTELLECTUAL PROPERTY RIGHTS.

These resources are intended for skilled developers designing with TI products. You are solely responsible for (1) selecting the appropriate TI products for your application, (2) designing, validating and testing your application, and (3) ensuring your application meets applicable standards, and any other safety, security, or other requirements. These resources are subject to change without notice. TI grants you permission to use these resources only for development of an application that uses the TI products described in the resource. Other reproduction and display of these resources is prohibited. No license is granted to any other TI intellectual property right or to any third party intellectual property right. TI disclaims responsibility for, and you will fully indemnify TI and its representatives against, any claims, damages, costs, losses, and liabilities arising out of your use of these resources.

TI's products are provided subject to TI's Terms of Sale (www.ti.com/legal/termsofsale.html) or other applicable terms available either on ti.com or provided in conjunction with such TI products. TI's provision of these resources does not expand or otherwise alter TI's applicable warranties or warranty disclaimers for TI products.

Mailing Address: Texas Instruments, Post Office Box 655303, Dallas, Texas 75265
Copyright © 2019, Texas Instruments Incorporated

Looking for pricing, stock, or lifecycle information?

Click below to explore more details on WIN SOURCE:

 [View TRF37C73IDSGT on WIN SOURCE](#)

 [Texas Instruments](#) Information

Optimize Your Supply Chain with WIN SOURCE Solutions

-  Global Sourcing Solution
-  Obsolete Management
-  Cost Control Management
-  Shortage Management
-  Alternative Solution
-  Excess Inventory Management