



**THE DATASHEET OF
TPS75100YFFT**



TPS7510x Low Dropout, Two-Bank LED Driver With PWM Brightness Control

1 Features

- Regulated Output Current with 2% LED-to-LED Matching
- Drives Up to Four LEDs at 25 mA Each in a Common Cathode Topology
- 28-mV Typical Dropout Voltage Extends Usable Supply Range in Li-Ion Battery Applications
- Brightness Control Using PWM Signals
- Two 2-LED Banks With Independent Enable and PWM Brightness Control per Bank
- No Internal Switching Signals—Eliminates EMI
- Default LED Current Eliminates External Components
 - Default Values from 3 mA to 10 mA (in 1-mA Increments) Available Using Innovative Factory EEPROM Programming
 - Optional External Resistor can be Used for High-Accuracy, User-Programmable Current
- Over current and Over temperature Protection
- Available in Wafer Chip-Scale Package or 2.50-mm × 2.50-mm WSON-10

2 Applications

- Keypad and Display Backlighting
- White and Color LEDs
- Cellular Handsets
- PDAs and Smartphones

3 Description

The TPS7510x linear low dropout (LDO) matching LED current source is optimized for low-power keypad and navigation pad LED backlighting applications. The device provides a constant current to up to four unmatched LEDs organized in two banks of two LEDs each in a common-cathode topology. Without an external resistor, the current source defaults to a factory-programmable, preset current level with $\pm 0.5\%$ accuracy (typical). An optional external resistor can be used to set initial brightness to user-programmable values with higher accuracy. Brightness can be varied from off to full brightness by inputting a pulse width modulation (PWM) signal on each enable pin (ENx, where x indicates LED bank A or B). Each bank has independent enable and brightness control, but current matching is done to all four channels concurrently. The input supply range is ideally suited for single-cell Li-Ion battery supplies and the TPS7510x can provide up to 25 mA per LED.

No internal switching signals are used, eliminating troublesome electromagnetic interference (EMI). The TPS7510x is offered in an ultra-small, 9-ball, 0.4-mm ball-pitch wafer chip-scale package (WCSP) and a 2.50-mm × 2.50-mm, 10-pin WSON package, yielding a very compact total solution size ideal for mobile handsets and portable backlighting applications. The device is fully specified over $T_J = -40^\circ\text{C}$ to $+85^\circ\text{C}$.

Device Information⁽¹⁾

PART NUMBER	PACKAGE	BODY SIZE (NOM)
TPS7510x	WSON (10)	2.50 mm × 2.50 mm
	DSBGA (9)	1.208 mm × 1.208 mm

(1) For all available packages, see the orderable addendum at the end of the data sheet.

Typical Application Diagram

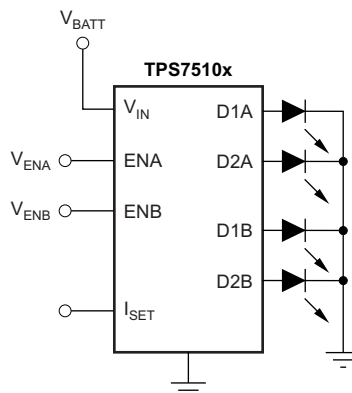

Table of Contents

1 Features	1	8 Application and Implementation	10
2 Applications	1	8.1 Application Information.....	10
3 Description	1	8.2 Typical Application	12
4 Revision History	2	9 Power Supply Recommendations	14
5 Pin Configuration and Functions	3	10 Layout	14
6 Specifications	4	10.1 Layout Guidelines	14
6.1 Absolute Maximum Ratings	4	10.2 Layout Example	14
6.2 ESD Ratings.....	4	11 Device and Documentation Support	15
6.3 Recommended Operating Conditions.....	4	11.1 Device Support.....	15
6.4 Thermal Information	4	11.2 Documentation Support	15
6.5 Electrical Characteristics.....	5	11.3 Related Links	15
6.6 Typical Characteristics	6	11.4 Receiving Notification of Documentation Updates	15
7 Detailed Description	8	11.5 Community Resources.....	15
7.1 Overview	8	11.6 Trademarks	16
7.2 Functional Block Diagram	8	11.7 Electrostatic Discharge Caution.....	16
7.3 Feature Description.....	9	11.8 Glossary	16
7.4 Device Functional Modes.....	9	12 Mechanical, Packaging, and Orderable Information	16

4 Revision History

NOTE: Page numbers for previous revisions may differ from page numbers in the current version.

Changes from Revision I (November 2013) to Revision J	Page
• Added <i>Device Information</i> table, <i>Typical Application Diagram</i> title to front-page diagram, <i>ESD Ratings</i> table, <i>Thermal Information</i> table, <i>Feature Description</i> section, <i>Device Functional Modes</i> section, <i>Application and Implementation</i> section, <i>Power Supply Recommendations</i> section, <i>Layout</i> section, <i>Device and Documentation Support</i> section, and <i>Mechanical, Packaging, and Orderable Information</i> section	1
• Changed SON to WSON throughout document	1
• Deleted pin out drawings from <i>Typical Application Diagram</i> figure.....	1
• Changed I/O status to <i>I</i> from <i>O</i> in D1B row of <i>Pin Functions</i> table	3
• Deleted <i>Dissipation Ratings</i> table.....	4

Changes from Revision H (January 2010) to Revision I	Page
• Changed test conditions for ground current parameter in the Electrical Characteristics	5
• Deleted Figure 14; duplicate mechanical image.	12

Changes from Revision G (March 2009) to Revision H	Page
• Revised ground current parameter, Electrical Characteristics; changed symbol from I_Q to I_{GND} ; added specifications for YFF and DSK packages.....	5
• Added YFF and DSK package specifications for current matching parameter, Electrical Characteristics	5
• Changed diode current accuracy parameter, Electrical Characteristics, to reflect YFF and DSK package specifications....	5
• Deleted operating junction temperature range specification from Electrical Characteristics table to eliminate redundancy .	5

5 Pin Configuration and Functions

**YFF Package
9-Pin DSBGA
Top View**

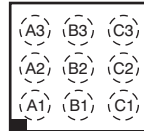

**DSK Package
10-Pin WSON
Top View**

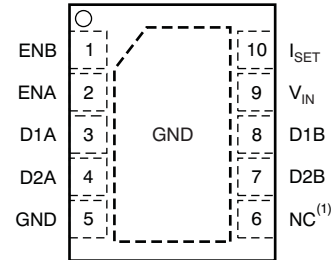

NOTE (1): Not connected

Pin Functions

PIN			I/O	DESCRIPTION
NAME	WCSP	WSON		
ENA	A3	2	I	Enable pin, Bank A. Driving this pin high turns on the current source to Bank A outputs. Driving this pin low turns off the current source to Bank A outputs. An applied PWM signal reduces the LED current (between 0 mA and the maximum current set by I_{SET}) as a function of the duty cycle of the PWM signal. ENA and ENB can be tied together. ENA can be left OPEN or connected to GND if not used. See the Application and Implementation section for more details.
D1A	B3	3	O	Diode source current output, Bank A. Connect to LED anode.
D2A	C3	4	O	Diode source current output, Bank A. Connect to LED anode.
ENB	A2	1	I	Enable pin, Bank B. Driving this pin high turns on the current source to Bank B outputs. Driving this pin low turns off the current source to Bank B outputs. An applied PWM signal reduces the LED current (between 0 mA and the maximum current set by I_{SET}) as a function of the duty cycle of the PWM signal. ENA and ENB can be tied together. ENB can be left OPEN or connected to GND if not used. See the Application and Implementation section for more details.
V_{IN}	B2	9	I	Supply input
GND	C2	5, Pad	—	Ground
I_{SET}	A1	10	I	An optional resistor can be connected between this pin and GND to set the maximum current through the LEDs. If no resistor is connected, I_{SET} defaults to the internally programmed value.
D1B	B1	8	O	Diode source current output, Bank B. Connect to LED anode.
D2B	C1	7	O	Diode source current output, Bank B. Connect to LED anode.
NC	—	6	—	Not internally connected

6 Specifications

6.1 Absolute Maximum Ratings

over operating free-air temperature range (unless otherwise noted)

	MIN	MAX	UNIT
V_{IN} range	-0.3	7	V
V_{ISET} , V_{ENA} , V_{ENB} , V_{DX} range	-0.3	V_{IN}	V
I_{DX} for D1A, D2A, D1B, D2B	35		mA
D1A, D2A, D1B, D2B short-circuit duration	Indefinite		
Continuous total power dissipation	Internally limited		
Junction temperature, T_J	-55	150	°C
Storage temperature, T_{stg}	-55	150	°C

6.2 ESD Ratings

		VALUE	UNIT
$V_{(ESD)}$ Electrostatic discharge	Human-body model (HBM), per ANSI/ESDA/JEDEC JS-001 ⁽¹⁾	±2000	V
	Charged-device model (CDM), per JEDEC specification JESD22-C101 ⁽²⁾	±500	

(1) JEDEC document JEP155 states that 500-V HBM allows safe manufacturing with a standard ESD control process.

(2) JEDEC document JEP157 states that 250-V CDM allows safe manufacturing with a standard ESD control process.

6.3 Recommended Operating Conditions

PARAMETER		MIN	NOM	MAX	UNIT
V_{IN}	Input voltage	2.7		5.5	V
I_{DX}	Operating current per LED	3		25	mA
t_{PWM}	On-time for PWM signal	33			µs
T_J	Operating junction temperature range	-40		85	°C

6.4 Thermal Information

THERMAL METRIC ⁽¹⁾		TPS7510x		UNIT
		YFF (DSBGA)	DSK (WSON)	
		9 PINS	10 PINS	
$R_{\theta JA}$	Junction-to-ambient thermal resistance	101.6	65.3	°C/W
$R_{\theta JC(top)}$	Junction-to-case (top) thermal resistance	1.2	54.0	°C/W
$R_{\theta JB}$	Junction-to-board thermal resistance	17.6	39.5	°C/W
Ψ_{JT}	Junction-to-top characterization parameter	0.6	1.6	°C/W
Ψ_{JB}	Junction-to-board characterization parameter	17.8	39.7	°C/W
$R_{\theta JC(bot)}$	Junction-to-case (bottom) thermal resistance	N/A	23.6	°C/W

(1) For more information about traditional and new thermal metrics, see the [Semiconductor and IC Package Thermal Metrics](#) application report.

6.5 Electrical Characteristics

over operating junction temperature range ($T_J = -40^\circ\text{C}$ to $+85^\circ\text{C}$), $V_{IN} = 3.8\text{ V}$, I_{DXA} and $I_{DXB} = 3.3\text{ V}$, $R_{SET} = 32.4\text{ k}\Omega$, and EN_A and $EN_B = 3.8\text{ V}$ (unless otherwise noted); typical values are at $T_A = 25^\circ\text{C}$

PARAMETER		TEST CONDITIONS		MIN	TYP	MAX	UNIT
I_{SHDN}	Shutdown supply current	$V_{ENA,B} = 0\text{ V}$, $V_{DX} = 0\text{ V}$			0.03	1	μA
I_{GND}	Ground current	DSK package	$I_{DX} \leq 5\text{ mA}$, $V_{IN} = 3.8\text{ V}$		170	230	μA
			$I_{DX} > 5\text{ mA}$, $V_{IN} = 3.8\text{ V}$		250	300	
		YFF package	$I_{DX} \leq 5\text{ mA}$, $V_{IN} = 4.5\text{ V}$		170	200	
			$I_{DX} > 5\text{ mA}$, $V_{IN} = 4.5\text{ V}$		250	300	
ΔI_D	Current matching ($I_{DXMAX} - I_{DXMIN} / I_{DXMAX}$) $\times 100\%$	$T_A = 25^\circ\text{C}$		0%	2%	4%	
		$T_A = -40^\circ\text{C}$ to $+85^\circ\text{C}$	YFF package	0%		5%	
			DSK package	0%		6%	
$\Delta I_{DX}/\Delta V_{IN}$	Line regulation	$3.5\text{ V} \leq V_{IN} \leq 4.5\text{ V}$, $I_{DX} = 5\text{ mA}$			2.0		$\%/V$
$\Delta I_{DX}/\Delta V_{DX}$	Load regulation	$1.8\text{ V} \leq V_{DX} \leq 3.5\text{ V}$, $I_{DX} = 5\text{ mA}$			0.8		$\%/V$
V_{DO}	Dropout voltage of any DX current source (V_{DX} at $I_{DX} = 0.8 \times I_{DX, nom}$)	$I_{DXnom} = 5\text{ mA}$			28	100	mV
		$I_{DXnom} = 15\text{ mA}$			70		
V_{ISET}	Reference voltage for current set			1.183	1.225	1.257	V
I_{OPEN}	Diode current accuracy ⁽¹⁾	$I_{SET} = \text{open}$, $V_{DX} = V_{IN} - 0.2\text{ V}$	YFF package		0.5%	3%	
			DSK package		0.5%	4%	
I_{SET}	I_{SET} pin current range			2.5		62.5	μA
k	I_{SET} to I_{DX} current ratio ⁽¹⁾				420		
V_{IH}	Enable high level input voltage			1.2			V
V_{IL}	Enable low level input voltage					0.4	V
I_{INA}	Enable pin A (V_{ENA}) input current	$V_{ENA} = 3.8\text{ V}$			5.0	6.1	μA
		$V_{ENA} = 1.8\text{ V}$			2.2		
I_{INB}	Enable pin B (V_{ENB}) input current	$V_{ENB} = 3.8\text{ V}$			4.0	4.9	μA
		$V_{ENB} = 1.8\text{ V}$			1.8		
t_{SD}	Shutdown delay time	Delay from EN_A and $EN_B = \text{low}$ to reach shutdown current ($I_{DX} = 0.1 \times I_{DX, nom}$)		5	13	30	μs
T_{SD}	Thermal shutdown temperature	Shutdown, temperature increasing			165		$^\circ\text{C}$
		Reset, temperature decreasing			140		

(1) Average of all four I_{DX} outputs.

6.6 Typical Characteristics

over operating junction temperature range ($T_J = -40^\circ\text{C}$ to $+85^\circ\text{C}$), $V_{IN} = 3.8\text{ V}$, D_{xA} and $D_{xB} = 3.3\text{ V}$, $R_{SET} = 32.4\text{ k}\Omega$, and EN_A and $EN_B = \text{high}$ (unless otherwise noted); typical values are at $T_A = 25^\circ\text{C}$

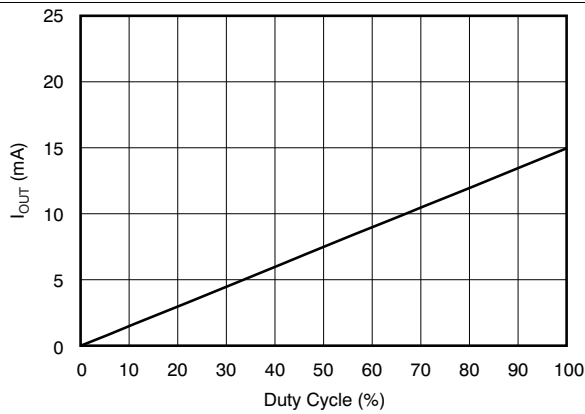

Figure 1. LED Current vs Duty Cycle ($f = 300\text{ Hz}$)

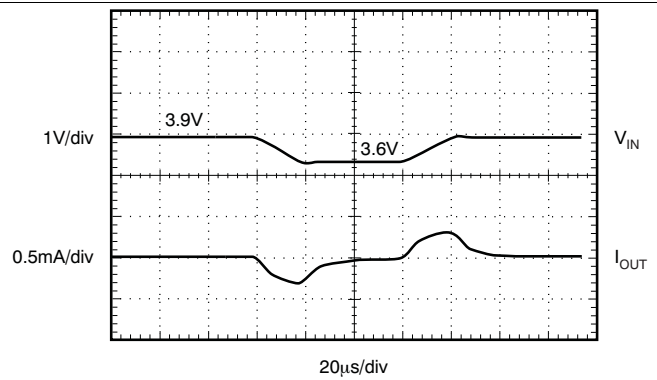

Figure 2. Line Transient (600-mV Pulse)

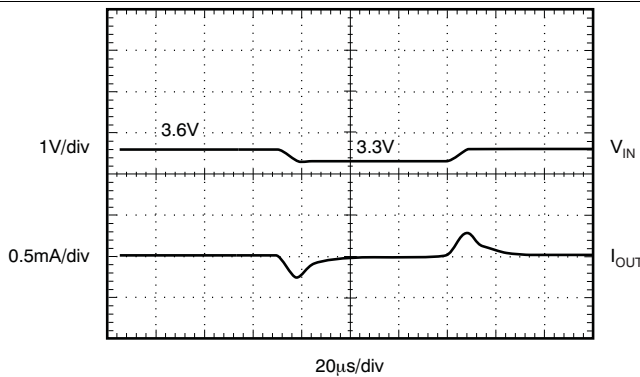

Figure 3. Line Transient (300-mV Pulse)

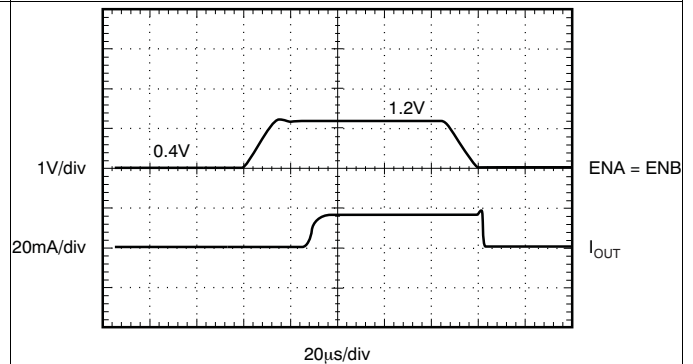

Figure 4. Dimming Response (Both Channels)

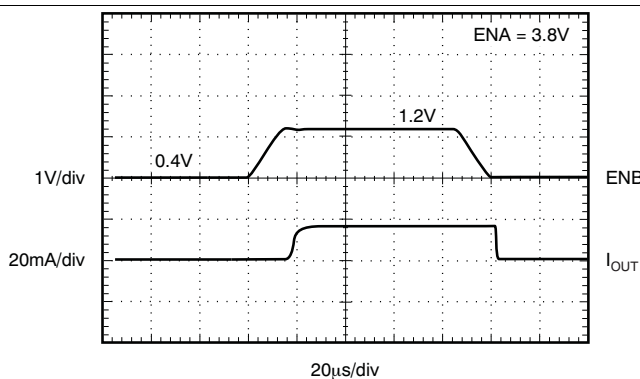

Figure 5. Dimming Response (Single Channel)

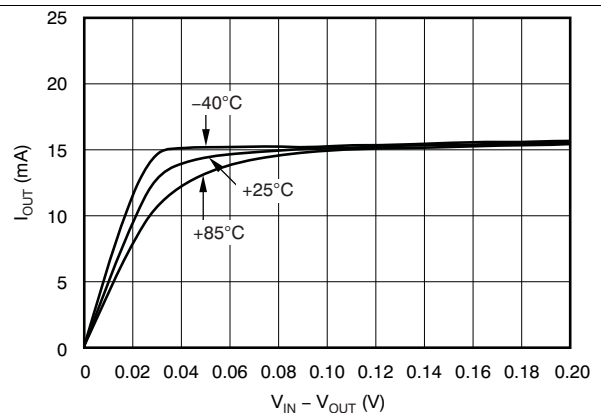

Figure 6. Output Current vs Headroom Voltage

Typical Characteristics (continued)

over operating junction temperature range ($T_J = -40^\circ\text{C}$ to $+85^\circ\text{C}$), $V_{IN} = 3.8\text{ V}$, DxA and $DxB = 3.3\text{ V}$, $R_{SET} = 32.4\text{ k}\Omega$, and ENA and $ENB = \text{high}$ (unless otherwise noted); typical values are at $T_A = 25^\circ\text{C}$

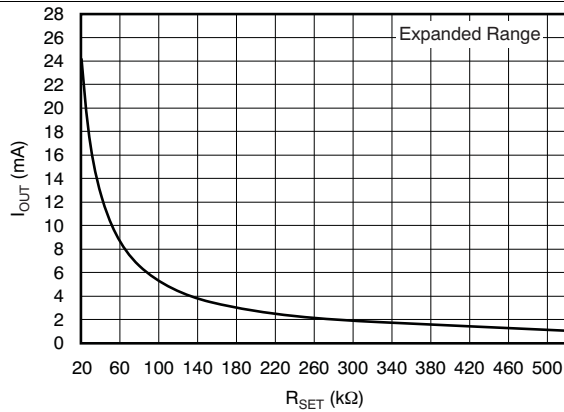

Figure 7. Output Current vs R_{SET}

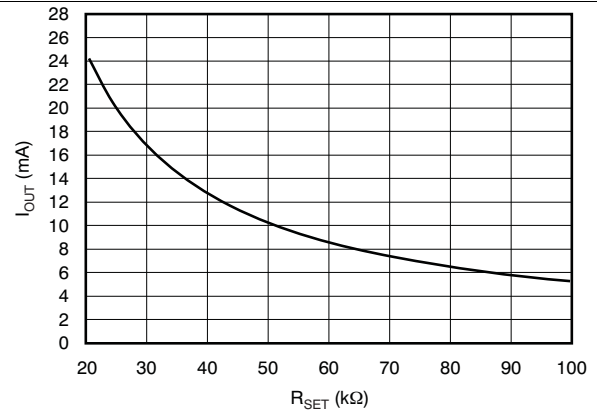

Figure 8. Output Current vs R_{SET}

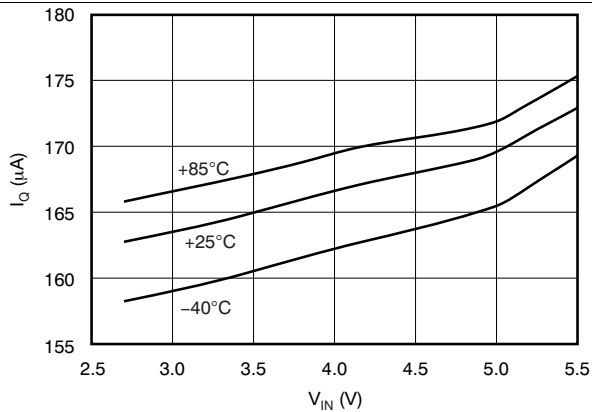
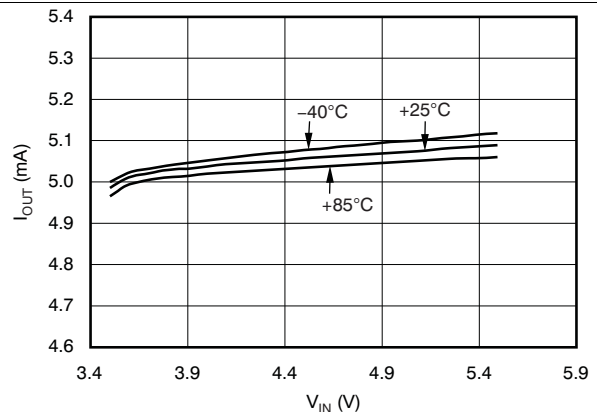
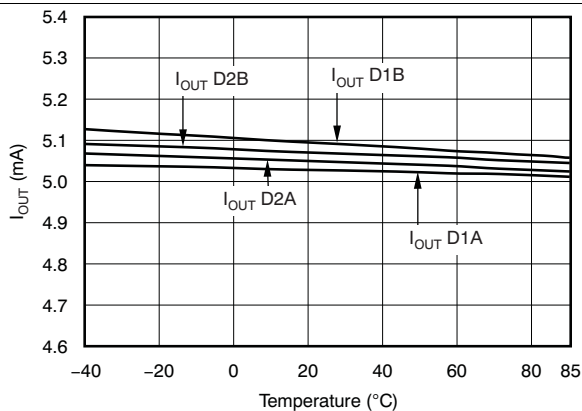

Figure 9. Ground Current vs Input Voltage



**Figure 10. TPS75105 Output Current vs Input Voltage
 $R_{SET} = \text{Open}$**



**Figure 11. TPS75105 Output Current vs Temperature
 $R_{SET} = \text{Open}$**

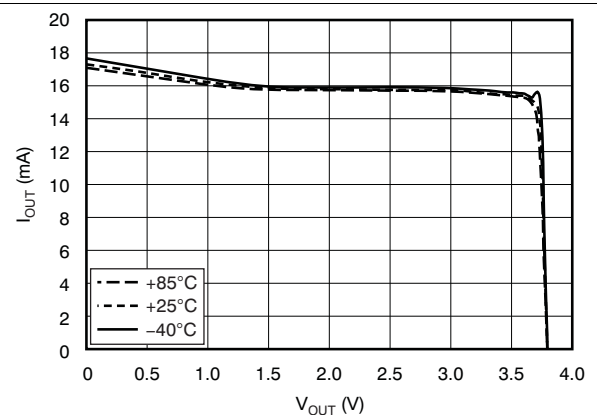

Figure 12. Output Current vs Output Voltage

7 Detailed Description

7.1 Overview

The TPS7510x linear low dropout (LDO) matching LED current source is optimized for low-power keypad and navigation pad LED backlighting applications. The device provides a constant current to up to four unmatched LEDs organized in two banks of two LEDs each in a common-cathode topology. Brightness can be varied from off to full brightness by inputting a pulse width modulation (PWM) signal on each enable pin (ENx, where x indicates LED bank A or B). Each bank has independent enable and brightness control, but current matching is done to all four channels concurrently. The input supply range is ideally suited for single-cell Li-Ion battery supplies and the TPS7510x can provide up to 25 mA per LED.

7.2 Functional Block Diagram

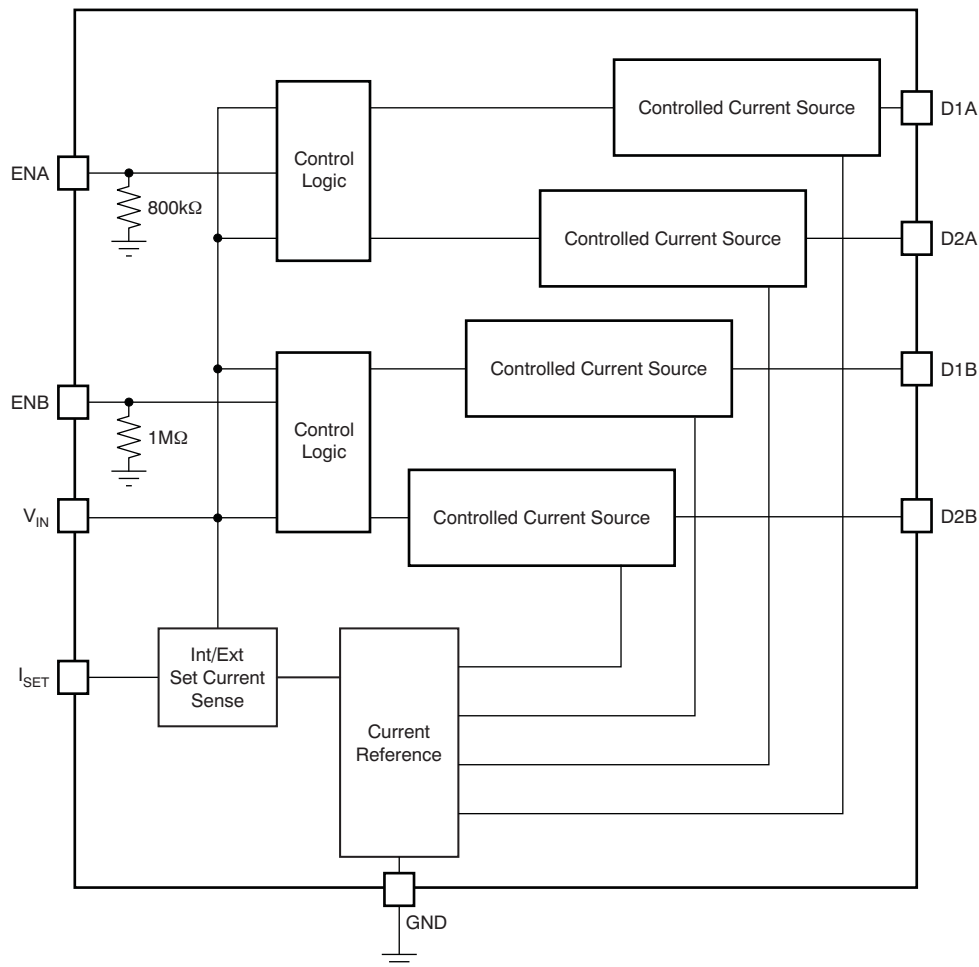

7.3 Feature Description

7.3.1 Load Regulation

The TPS7510x is designed to provide very tight load regulation. In the case of a fixed current source, the output load change is a change in voltage. Tight load regulation means that output voltages (LED forward voltages) with large variations can be used without impacting the fixed current being sourced by the output or the output-to-output current matching. The permissible variation on the output not only allows for large variations in white LED forward voltages, but even permits the use of different color LEDs on different outputs with minimal effect on output current.

7.3.2 Line Regulation

The TPS7510x is also designed to provide very tight line regulation. This architecture allows for voltage transient events to occur on the power supply (battery) without effecting the fixed output current levels or the output-to-output current matching. A prime example of such a supply transient event is the occurrence of a transmit pulse on the radio of a mobile handset. These transient pulses can cause variations of 300 mV and 600 mV on the supply to the TPS7510x. The line regulation limitation is that the lower supply voltage level of the event does not cause the input-to-output voltage difference to drop below the dropout voltage range.

7.4 Device Functional Modes

7.4.1 LED ON

Apply 1.2 V or more to ENx to turn the LED bank on.

7.4.2 LED OFF

Apply a voltage less than or equal to 0.4V to ENx to turn the LED bank off.

8 Application and Implementation

NOTE

Information in the following applications sections is not part of the TI component specification, and TI does not warrant its accuracy or completeness. TI's customers are responsible for determining suitability of components for their purposes. Customers should validate and test their design implementation to confirm system functionality.

8.1 Application Information

The TPS7510x provides a constant current to up to four unmatched LEDs organized in two banks of two LEDs each in a common-cathode topology. Without an external resistor, the current source defaults to a factory-programmable, preset current level with $\pm 0.5\%$ accuracy (typical). An optional external resistor can be used to set initial brightness to user-programmable values with higher accuracy. Brightness can be varied from off to full brightness by inputting a pulse width modulation (PWM) signal on each enable pin (ENx, where x indicates LED bank A or B). Each bank has independent enable and brightness control, but current matching is done to all four channels concurrently. The input supply range is ideally suited for single-cell Li-Ion battery supplies and the TPS7510x can provide up to 25 mA per LED. No internal switching signals are used, eliminating troublesome electromagnetic interference (EMI). The device is fully specified over $T_J = -40^\circ\text{C}$ to $+85^\circ\text{C}$.

8.1.1 Setting the Output Current Level

The TPS7510x is a quad matched current source. Each of the four current source output levels is set by a single reference current. An internal voltage reference of 1.225 V (nominal) in combination with a resistor sets the reference current level. This reference current is then mirrored onto each of the four outputs with a ratio of typically 420:1. The resistor required to set the LED current is calculated using [Equation 1](#):

$$R_{\text{ISET}} = \frac{K \times V_{\text{ISET}}}{I_{\text{LED}}}$$

where:

- K is the current ratio
- V_{ISET} is the internal reference voltage
- I_{LED} is the desired LED current

(1)

For example, to set the LED current level to 10mA, a resistor value of 51.1 k Ω is required. This value sets up a reference current of 23.9 μA (1.22 V / 51.1 k Ω). In turn, this reference current is mirrored to each output current source, resulting in an output current of 10 mA (23.9 μA \times 420).

The TPS7510x offers two methods for setting the output current levels. The LED current is set either by connecting a resistor (calculated using [Equation 1](#)) from the I_{SET} pin to GND, or leaving I_{SET} unconnected to employ the factory-programmed R_{SET} resistance. The internal programmed resistance is implemented using high-precision processing and yields a reference current accuracy of 0.5%, nominal. Accuracy using external resistors is subject to the tolerance of the external resistor and the accuracy of the internal reference voltage.

The TPS7510x automatically detects the presence of an external resistor by monitoring the current out of the I_{SET} pin. Current levels in excess of 3 μA signify the presence of an external resistor and the device uses the external resistor to set the reference current. If the current from I_{SET} is less than 3 μA , the device defaults to the preset internal reference set resistor. The TPS7510x is available with eight preset current levels, from 3 mA to 10 mA (per output) in 1-mA increments. Solutions using the preset internal current level eliminate an external component, thereby increasing accuracy and reducing cost.

Application Information (continued)
Table 1. Recommended (1% Tolerance) Set Resistor Values

R_{SET} (k Ω)	I_{SET} (μ A)	I_{DX} (mA) ⁽¹⁾
511	2.4	1.0
255	4.8	2.0
169	7.2	3.0
127	9.6	4.1
102	12.0	5.0
84.5	14.5	6.1
73.2	16.7	7.0
64.9	18.9	7.9
56.2	21.8	9.2
51.1	24.0	10.1
46.4	26.4	11.1
42.2	29.0	12.2
39.2	31.3	13.1
36.5	33.6	14.1
34.0	36.0	15.1
32.4	37.8	15.9
30.1	40.7	17.1
28.7	42.7	17.9
26.7	45.9	19.3
25.5	48.0	20.2
24.3	50.4	21.2
23.2	52.8	22.2
22.1	55.4	23.3
21.5	57.0	23.9
20.5	59.8	25.1

(1) $I_{DX} = (V_{SET} / R_{SET}) \times k$.

8.1.2 Limitations on LED Forward Voltages

The TPS7510x is a linear current source implementing LDO regulator building blocks. Therefore, to maintain accurate operation, there are some limitations to the forward (output) voltages that can be used. The first limitation is the maximum LED forward voltage. The dropout voltage must be considered because LDO technology is employed. The TPS7510x is an ultra-low dropout device with typical dropouts in the range of 30 mV at 5 mA. Care must be taken in the design to ensure that the difference between the lowest possible input voltage (for example, battery cut-off) and the highest possible forward voltage yields at least 100 mV of headroom. Headroom levels less than dropout decrease the accuracy of the current source (see [Figure 6](#)).

The other limitation to consider is the minimum output voltage required to yield accurate operation. The current source employs NMOS MOSFETs, and a minimum forward LED voltage of approximately 1.5 V on the output is required to maintain highest accuracy. The TPS7510x is ideal for white LEDs and color LEDs with forward voltages greater than 1.5 V. This range includes red LEDs that have typical forward voltages of 1.7 V.

8.1.3 Use of External Capacitors

The TPS7510x does not require the use of any external capacitors for stable operation. Nominal stray and power-supply decoupling capacitance on the input is adequate for stable operation. Capacitors are not needed for stability and are therefore not recommended on the outputs.

8.1.4 Use of Unused Outputs or Tying Outputs Together

Unused outputs can be left unconnected or tied to the V_{IN} supply. Although open outputs are acceptable, tying unused outputs to the V_{IN} supply increases ESD protection. Connecting unused outputs to ground violates the minimum recommended output voltage, results in current levels that potentially exceed the set or preset LED current, and must be avoided.

Connecting outputs in parallel is an acceptable way of increasing the amount of LED current drive. This configuration is a useful trick when the higher current level is a multiple of the preset value.

8.1.5 Use of Enable Pins for PWM Dimming

The TPS7510x divides control of the LED outputs into two banks of two current sources each. Each bank is controlled by the use of an independent, active-high enable pin (ENA and ENB). The enable pin can be used for standard ON or OFF operation of the current source, driven by standard logic levels from processor GPIO pins, for example. Drive ENx high to turn on the bank of LEDs; drive ENx low to turn off the bank of LEDs.

Another use of the enable pins is for LED dimming. LED brightness is a function of the current level being driven across the diode and the time that current is being driven through the diode. The perceived brightness of an LED can be changed by either varying the current level or, more effectively, by changing the time in which that current is present. When a PWM signal is input into the enable pin, the duty cycle (high- or on-time) determines how long the fixed current is driven across the LEDs. Reducing or increasing that duration has the effect of dimming or brightening the LED, without having to employ the more complex method of varying the current level. This technique is particularly useful for reducing LED brightness in low ambient light conditions, where LED brightness is not required, thereby decreasing current consumption. The enable pins can also be used for LED blinking, varying blink rates based on system status.

Although providing many useful applications, PWM dimming does have a minimum duty cycle required to achieve the required current level. The recommended minimum on-time of the TPS7510x is approximately 33 μ s. On-times less than 33 μ s result in reductions in the output current by not allowing enough time for the output to reach the desired current level. Also, having both enables switching together, asynchronously, or having one enable on at all times, effects the minimum recommended on-time (see [Figure 4](#) and [Figure 5](#)). If one enable is already on, the speed at which the other channel turns on is faster than if both channels are turning on together or if the other channel is off. Therefore, already having one channel enabled allows for approximately 10- μ s to 12- μ s shorter minimum on-times for the switching channel.

Unused enable pins can be left unconnected or connected to ground to minimize current consumption. Connecting unused enable pins to ground increases ESD protection. If connected to V_{IN} , a small amount of current drains through the enable input (see the [Electrical Characteristics](#) table).

8.2 Typical Application

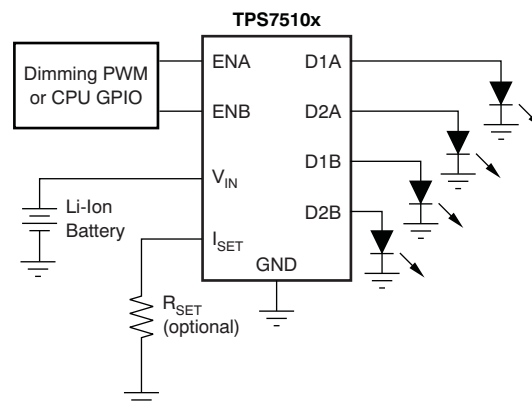

Figure 13. Typical Application Diagram

Typical Application (continued)

8.2.1 Design Requirements

Table 2 shows the design requirements.

Table 2. Design Parameters

PARAMETER	DESIGN REQUIREMENT
Input voltage	3.8 V
Number of LEDs	4
LED current	5 mA (per LED)

8.2.2 Detailed Design Procedure

Select the TPS75105 so that no external resistor is required to set the LED current.

8.2.3 Application Curve

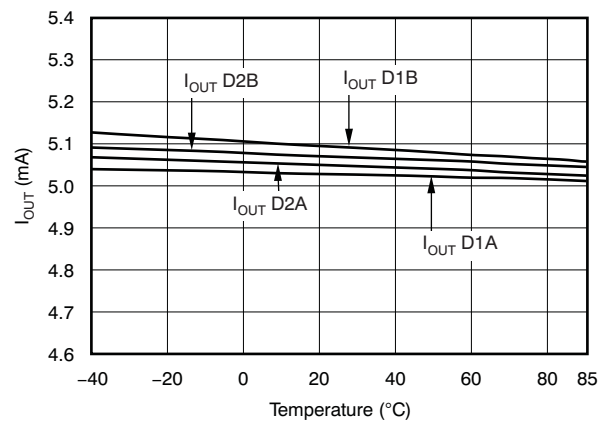

$R_{SET} = \text{open}$

Figure 14. TPS75105 Output Current vs Temperature

9 Power Supply Recommendations

The TPS7510x is designed to operate with an input voltage between 2.7 V to 5.5 V.

10 Layout

10.1 Layout Guidelines

Figure 15 demonstrates an example layout for the WSON package.

10.2 Layout Example

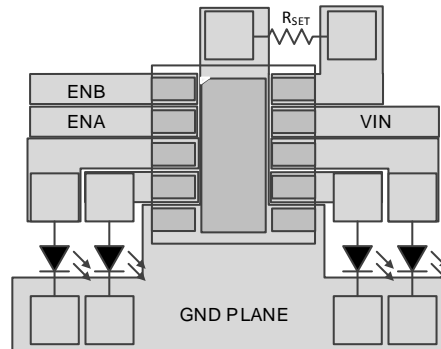

Figure 15. Layout Example for the WSON (DSK) Package

11 Device and Documentation Support

11.1 Device Support

11.1.1 Development Support

Two evaluation modules (EVMs) are available to assist in the initial circuit performance evaluation using the TPS7510x. The TPS75105EVM-174 and TPS75105DSKEVM-529 evaluation modules (and related user guides) can be requested at the Texas Instruments website through the product folders or purchased directly from the TI eStore.

11.1.2 Device Nomenclature

PRODUCT ID	OPTIONS ⁽¹⁾⁽²⁾
TPS7510x <i>yyyz</i>	<p>X is the nominal default diode output current (for example, 3 = 3 mA, 5 = 5 mA, and 0 = 10 mA).</p> <p>YYY is the package designator.</p> <p>Z is the reel quantity (R = 3000, T = 250).</p>

- (1) For the most current package and ordering information see the Package Option Addendum at the end of this document, or see the TI web site at www.ti.com.
- (2) Default set currents from 3 mA to 10 mA in 1-mA increments are available through the use of innovative factory EEPROM programming. Minimum order quantities may apply. Contact factory for details and availability.

11.2 Documentation Support

11.2.1 Related Documentation

For related documentation see the following:

- [TPS75105EVM-174 Evaluation Module](#) (SLVU182)
- [TPS75105DSKEVM-529 Evaluation Module](#) (SLVU334)

11.3 Related Links

The table below lists quick access links. Categories include technical documents, support and community resources, tools and software, and quick access to sample or buy.

Table 3. Related Links

PARTS	PRODUCT FOLDER	SAMPLE & BUY	TECHNICAL DOCUMENTS	TOOLS & SOFTWARE	SUPPORT & COMMUNITY
TPS75100	Click here	Click here	Click here	Click here	Click here
TPS75103	Click here	Click here	Click here	Click here	Click here
TPS75105	Click here	Click here	Click here	Click here	Click here

11.4 Receiving Notification of Documentation Updates

To receive notification of documentation updates, navigate to the device product folder on ti.com. In the upper right corner, click on *Alert me* to register and receive a weekly digest of any product information that has changed. For change details, review the revision history included in any revised document.

11.5 Community Resources

The following links connect to TI community resources. Linked contents are provided "AS IS" by the respective contributors. They do not constitute TI specifications and do not necessarily reflect TI's views; see TI's [Terms of Use](#).

TI E2E™ Online Community *TI's Engineer-to-Engineer (E2E) Community*. Created to foster collaboration among engineers. At e2e.ti.com, you can ask questions, share knowledge, explore ideas and help solve problems with fellow engineers.

Design Support *TI's Design Support* Quickly find helpful E2E forums along with design support tools and contact information for technical support.

11.6 Trademarks

E2E is a trademark of Texas Instruments.
All other trademarks are the property of their respective owners.

11.7 Electrostatic Discharge Caution



This integrated circuit can be damaged by ESD. Texas Instruments recommends that all integrated circuits be handled with appropriate precautions. Failure to observe proper handling and installation procedures can cause damage.

ESD damage can range from subtle performance degradation to complete device failure. Precision integrated circuits may be more susceptible to damage because very small parametric changes could cause the device not to meet its published specifications.

11.8 Glossary

[SLYZ022](#) — *TI Glossary*.

This glossary lists and explains terms, acronyms, and definitions.

12 Mechanical, Packaging, and Orderable Information

The following pages include mechanical, packaging, and orderable information. This information is the most current data available for the designated devices. This data is subject to change without notice and revision of this document. For browser-based versions of this data sheet, refer to the left-hand navigation.

PACKAGING INFORMATION

Orderable Device	Status (1)	Package Type	Package Drawing	Pins	Package Qty	Eco Plan (2)	Lead/Ball Finish (6)	MSL Peak Temp (3)	Op Temp (°C)	Device Marking (4/5)	Samples
TPS75100DSKR	ACTIVE	SON	DSK	10	3000	Green (RoHS & no Sb/Br)	CU NIPDAU	Level-1-260C-UNLIM	-40 to 85	SKX	Samples
TPS75100DSKT	ACTIVE	SON	DSK	10	250	Green (RoHS & no Sb/Br)	CU NIPDAU	Level-1-260C-UNLIM	-40 to 85	SKX	Samples
TPS75100YFFR	ACTIVE	DSBGA	YFF	9	3000	Green (RoHS & no Sb/Br)	SNAGCU	Level-1-260C-UNLIM	-40 to 85	FB	Samples
TPS75100YFFT	ACTIVE	DSBGA	YFF	9	250	Green (RoHS & no Sb/Br)	SNAGCU	Level-1-260C-UNLIM	-40 to 85	FB	Samples
TPS75103YFFR	ACTIVE	DSBGA	YFF	9	3000	Green (RoHS & no Sb/Br)	SNAGCU	Level-1-260C-UNLIM	-40 to 85	FC	Samples
TPS75103YFFT	ACTIVE	DSBGA	YFF	9	250	Green (RoHS & no Sb/Br)	SNAGCU	Level-1-260C-UNLIM	-40 to 85	FC	Samples
TPS75105DSKR	ACTIVE	SON	DSK	10	3000	Green (RoHS & no Sb/Br)	CU NIPDAU	Level-1-260C-UNLIM	-40 to 85	CHH	Samples
TPS75105DSKT	ACTIVE	SON	DSK	10	250	Green (RoHS & no Sb/Br)	CU NIPDAU	Level-1-260C-UNLIM	-40 to 85	CHH	Samples
TPS75105YFFR	ACTIVE	DSBGA	YFF	9	3000	Green (RoHS & no Sb/Br)	SNAGCU	Level-1-260C-UNLIM	-40 to 85	FE	Samples
TPS75105YFFT	ACTIVE	DSBGA	YFF	9	250	Green (RoHS & no Sb/Br)	SNAGCU	Level-1-260C-UNLIM	-40 to 85	FE	Samples

(1) The marketing status values are defined as follows:

ACTIVE: Product device recommended for new designs.

LIFEBUY: TI has announced that the device will be discontinued, and a lifetime-buy period is in effect.

NRND: Not recommended for new designs. Device is in production to support existing customers, but TI does not recommend using this part in a new design.

PREVIEW: Device has been announced but is not in production. Samples may or may not be available.

OBSOLETE: TI has discontinued the production of the device.

(2) Eco Plan - The planned eco-friendly classification: Pb-Free (RoHS), Pb-Free (RoHS Exempt), or Green (RoHS & no Sb/Br) - please check <http://www.ti.com/productcontent> for the latest availability information and additional product content details.

TBD: The Pb-Free/Green conversion plan has not been defined.

Pb-Free (RoHS): TI's terms "Lead-Free" or "Pb-Free" mean semiconductor products that are compatible with the current RoHS requirements for all 6 substances, including the requirement that lead not exceed 0.1% by weight in homogeneous materials. Where designed to be soldered at high temperatures, TI Pb-Free products are suitable for use in specified lead-free processes.

Pb-Free (RoHS Exempt): This component has a RoHS exemption for either 1) lead-based flip-chip solder bumps used between the die and package, or 2) lead-based die adhesive used between the die and leadframe. The component is otherwise considered Pb-Free (RoHS compatible) as defined above.

Green (RoHS & no Sb/Br): TI defines "Green" to mean Pb-Free (RoHS compatible), and free of Bromine (Br) and Antimony (Sb) based flame retardants (Br or Sb do not exceed 0.1% by weight in homogeneous material)

- (3) MSL, Peak Temp. - The Moisture Sensitivity Level rating according to the JEDEC industry standard classifications, and peak solder temperature.
- (4) There may be additional marking, which relates to the logo, the lot trace code information, or the environmental category on the device.
- (5) Multiple Device Markings will be inside parentheses. Only one Device Marking contained in parentheses and separated by a "~" will appear on a device. If a line is indented then it is a continuation of the previous line and the two combined represent the entire Device Marking for that device.
- (6) Lead/Ball Finish - Orderable Devices may have multiple material finish options. Finish options are separated by a vertical ruled line. Lead/Ball Finish values may wrap to two lines if the finish value exceeds the maximum column width.

Important Information and Disclaimer:The information provided on this page represents TI's knowledge and belief as of the date that it is provided. TI bases its knowledge and belief on information provided by third parties, and makes no representation or warranty as to the accuracy of such information. Efforts are underway to better integrate information from third parties. TI has taken and continues to take reasonable steps to provide representative and accurate information but may not have conducted destructive testing or chemical analysis on incoming materials and chemicals. TI and TI suppliers consider certain information to be proprietary, and thus CAS numbers and other limited information may not be available for release.

In no event shall TI's liability arising out of such information exceed the total purchase price of the TI part(s) at issue in this document sold by TI to Customer on an annual basis.

TAPE AND REEL INFORMATION



QUADRANT ASSIGNMENTS FOR PIN 1 ORIENTATION IN TAPE



*All dimensions are nominal

Device	Package Type	Package Drawing	Pins	SPQ	Reel Diameter (mm)	Reel Width W1 (mm)	A0 (mm)	B0 (mm)	K0 (mm)	P1 (mm)	W (mm)	Pin1 Quadrant
TPS75100DSKR	SON	DSK	10	3000	179.0	8.4	2.73	2.73	0.8	4.0	8.0	Q2
TPS75100DSKT	SON	DSK	10	250	179.0	8.4	2.73	2.73	0.8	4.0	8.0	Q2
TPS75100YFFR	DSBGA	YFF	9	3000	180.0	8.4	1.34	1.34	0.81	4.0	8.0	Q1
TPS75100YFFT	DSBGA	YFF	9	250	180.0	8.4	1.34	1.34	0.81	4.0	8.0	Q1
TPS75103YFFR	DSBGA	YFF	9	3000	180.0	8.4	1.45	1.45	0.8	4.0	8.0	Q1
TPS75103YFFT	DSBGA	YFF	9	250	180.0	8.4	1.45	1.45	0.8	4.0	8.0	Q1
TPS75105DSKR	SON	DSK	10	3000	179.0	8.4	2.73	2.73	0.8	4.0	8.0	Q2
TPS75105DSKT	SON	DSK	10	250	179.0	8.4	2.73	2.73	0.8	4.0	8.0	Q2
TPS75105YFFR	DSBGA	YFF	9	3000	180.0	8.4	1.45	1.45	0.8	4.0	8.0	Q1
TPS75105YFFT	DSBGA	YFF	9	250	180.0	8.4	1.45	1.45	0.8	4.0	8.0	Q1

TAPE AND REEL BOX DIMENSIONS

*All dimensions are nominal

Device	Package Type	Package Drawing	Pins	SPQ	Length (mm)	Width (mm)	Height (mm)
TPS75100DSKR	SON	DSK	10	3000	203.0	203.0	35.0
TPS75100DSKT	SON	DSK	10	250	203.0	203.0	35.0
TPS75100YFFR	DSBGA	YFF	9	3000	182.0	182.0	20.0
TPS75100YFFT	DSBGA	YFF	9	250	182.0	182.0	20.0
TPS75103YFFR	DSBGA	YFF	9	3000	210.0	185.0	35.0
TPS75103YFFT	DSBGA	YFF	9	250	210.0	185.0	35.0
TPS75105DSKR	SON	DSK	10	3000	203.0	203.0	35.0
TPS75105DSKT	SON	DSK	10	250	203.0	203.0	35.0
TPS75105YFFR	DSBGA	YFF	9	3000	210.0	185.0	35.0
TPS75105YFFT	DSBGA	YFF	9	250	210.0	185.0	35.0

YFF0009

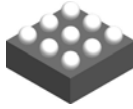

PACKAGE OUTLINE

DSBGA - 0.625 mm max height

DIE SIZE BALL GRID ARRAY

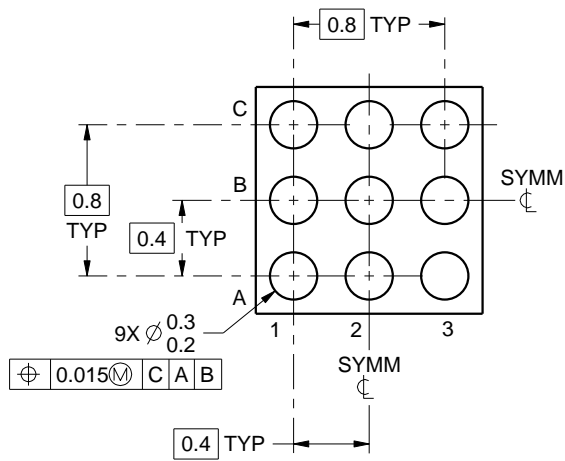
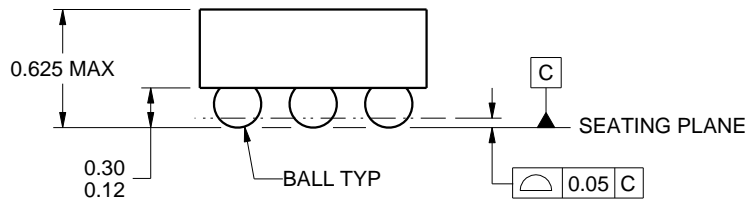
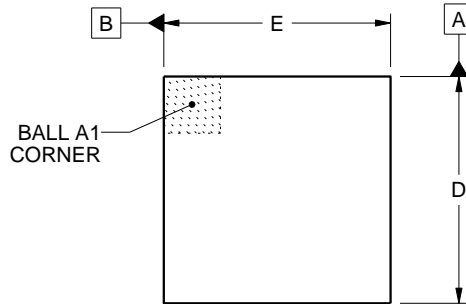

D: Max = 1.238 mm, Min = 1.178 mm
E: Max = 1.238 mm, Min = 1.178 mm

4219552/A 05/2016

NOTES:

- 1. All linear dimensions are in millimeters. Any dimensions in parenthesis are for reference only. Dimensioning and tolerancing per ASME Y14.5M.
- 2. This drawing is subject to change without notice.

EXAMPLE BOARD LAYOUT

YFF0009

DSBGA - 0.625 mm max height

DIE SIZE BALL GRID ARRAY

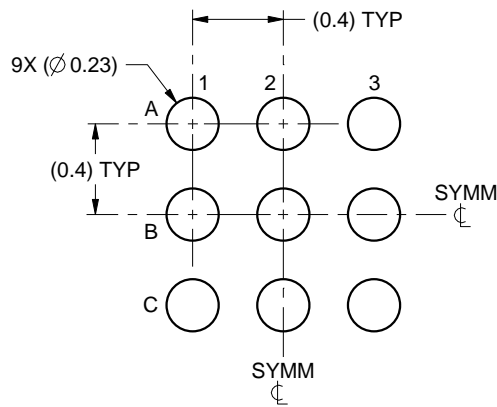

LAND PATTERN EXAMPLE
SCALE:30X

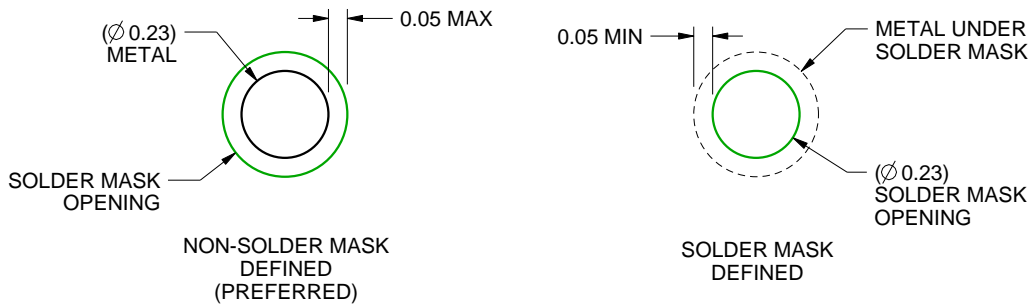

SOLDER MASK DETAILS
NOT TO SCALE

4219552/A 05/2016

NOTES: (continued)

3. Final dimensions may vary due to manufacturing tolerance considerations and also routing constraints. For more information, see Texas Instruments literature number SNVA009 (www.ti.com/lit/snva009).

EXAMPLE STENCIL DESIGN

YFF0009

DSBGA - 0.625 mm max height

DIE SIZE BALL GRID ARRAY

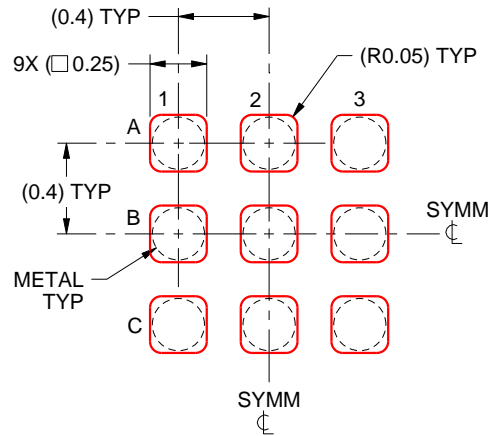

SOLDER PASTE EXAMPLE
BASED ON 0.1 mm THICK STENCIL
SCALE:30X

4219552/A 05/2016

NOTES: (continued)

4. Laser cutting apertures with trapezoidal walls and rounded corners may offer better paste release.

DSK (S-PDSO-N10)

PLASTIC QUAD FLATPACK

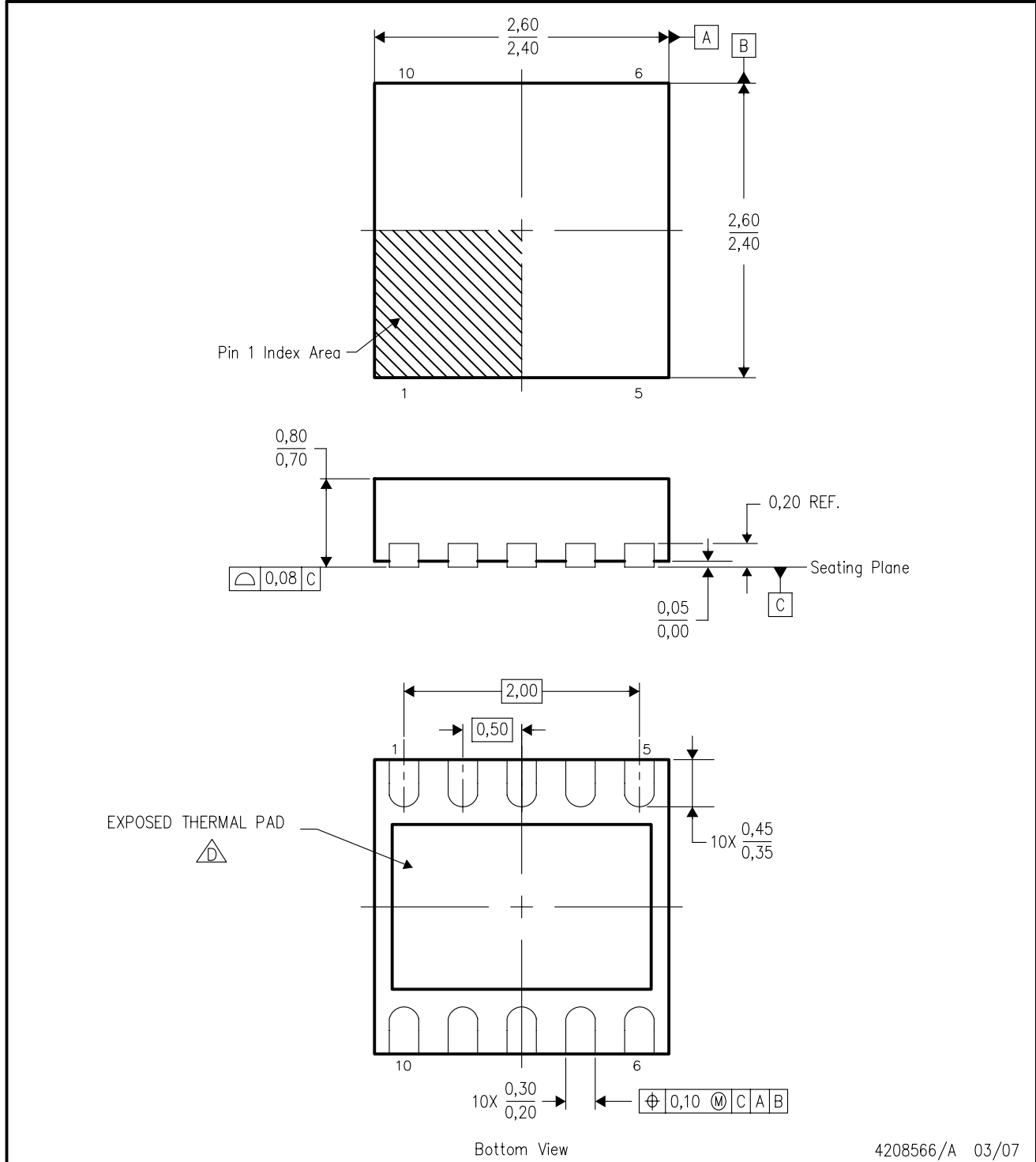

4208566/A 03/07

- NOTES:
- A. All linear dimensions are in millimeters. Dimensioning and tolerancing per ASME Y14.5M-1994.
 - B. This drawing is subject to change without notice.
 - C. Small Outline No-Lead (SON) package configuration.
 -  The package thermal pad must be soldered to the board for thermal and mechanical performance. See the Product Data Sheet for details regarding the exposed thermal pad dimensions.

THERMAL PAD MECHANICAL DATA

DSK (R-PWSON-N10)

PLASTIC SMALL OUTLINE NO-LEAD

THERMAL INFORMATION

This package incorporates an exposed thermal pad that is designed to be attached directly to an external heatsink. The thermal pad must be soldered directly to the printed circuit board (PCB). After soldering, the PCB can be used as a heatsink. In addition, through the use of thermal vias, the thermal pad can be attached directly to the appropriate copper plane shown in the electrical schematic for the device, or alternatively, can be attached to a special heatsink structure designed into the PCB. This design optimizes the heat transfer from the integrated circuit (IC).

For information on the Quad Flatpack No-Lead (QFN) package and its advantages, refer to Application Report, QFN/SON PCB Attachment, Texas Instruments Literature No. SLUA271. This document is available at www.ti.com.

The exposed thermal pad dimensions for this package are shown in the following illustration.

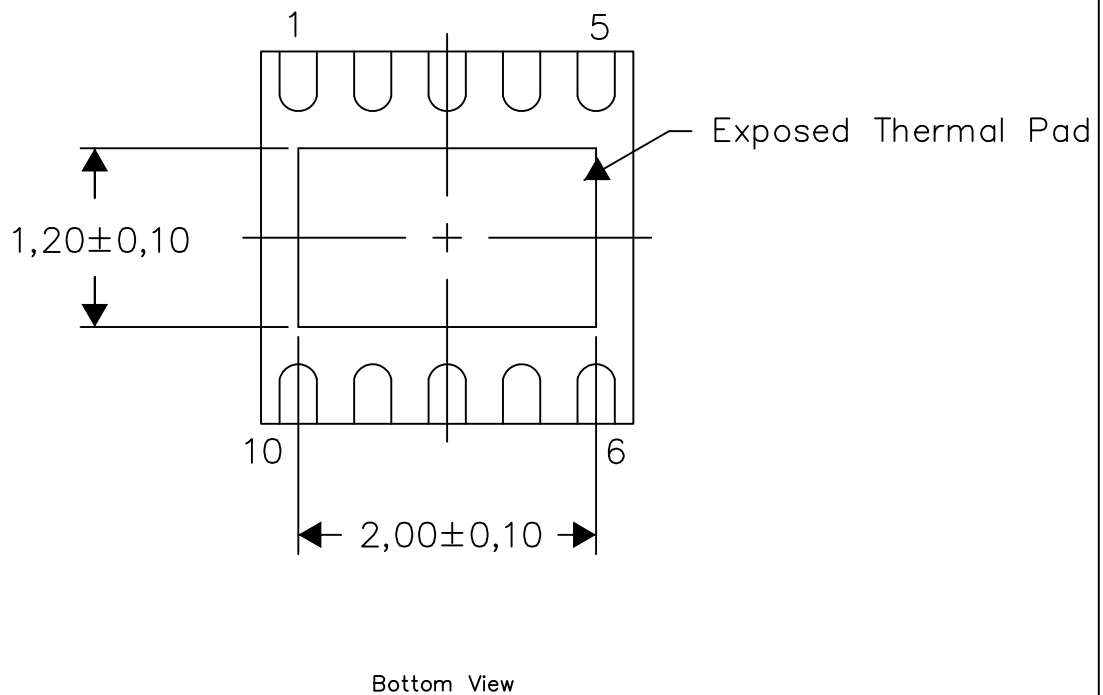

Exposed Thermal Pad Dimensions

4208579-2/E 12/12

NOTE: All linear dimensions are in millimeters

DSK (R-PWSON-N10)

PLASTIC SMALL OUTLINE NO-LEAD

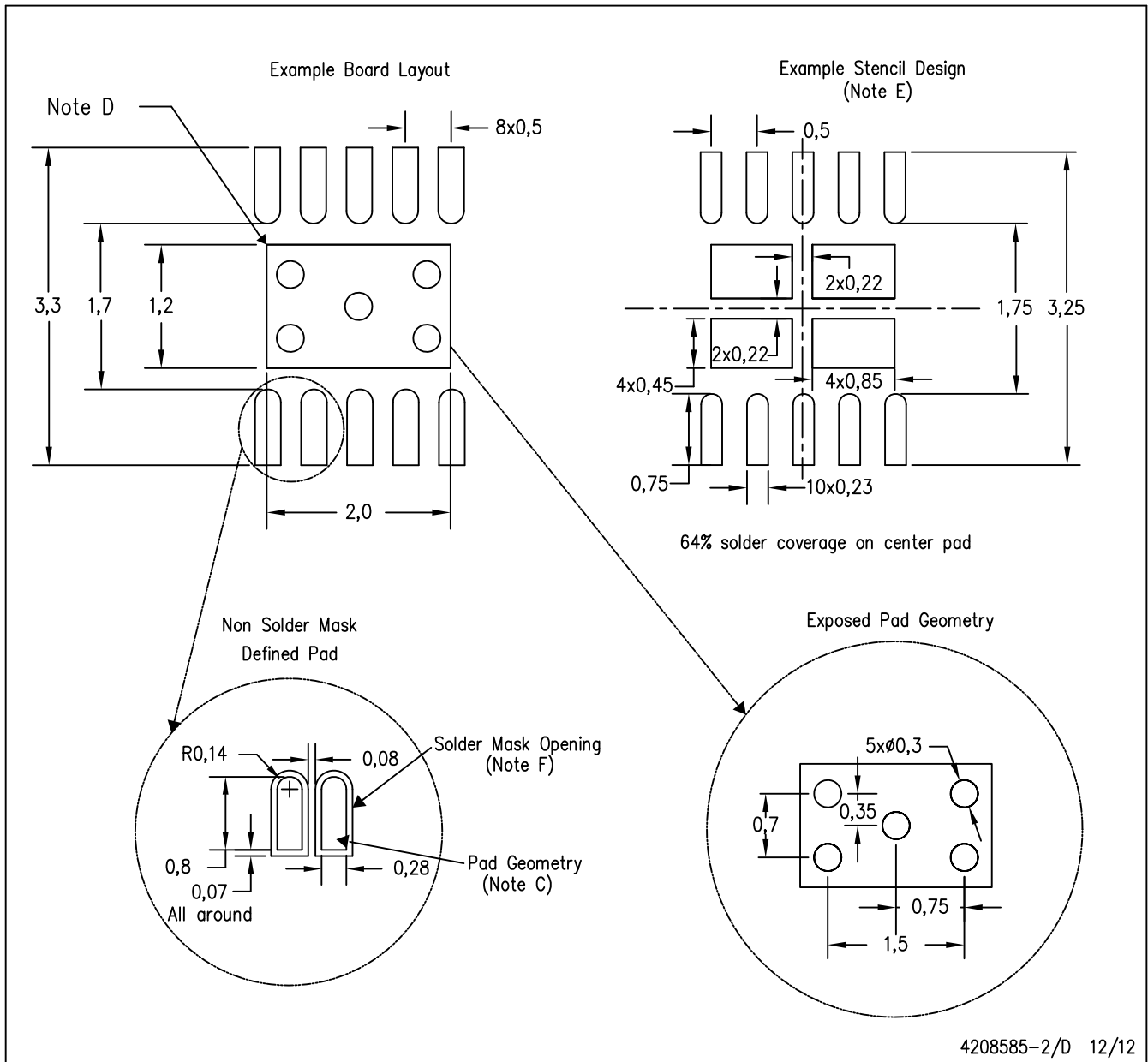

- NOTES:
- All linear dimensions are in millimeters.
 - This drawing is subject to change without notice.
 - Publication IPC-SM-782 is recommended for alternate designs.
 - This package is designed to be soldered to a thermal pad on the board. Refer to Application Note, Quad Flat-Pack Packages, Texas Instruments Literature No. SLUA271, and also the Product Data Sheets for specific thermal information, via requirements, and recommended board layout. These documents are available at www.ti.com <<http://www.ti.com>>.
 - Laser cutting apertures with trapezoidal walls and also rounding corners will offer better paste release. Customers should contact their board assembly site for stencil design recommendations. Refer to IPC 7525 for stencil design considerations.
 - Customers should contact their board fabrication site for minimum solder mask web tolerances between signal pads.

IMPORTANT NOTICE

Texas Instruments Incorporated (TI) reserves the right to make corrections, enhancements, improvements and other changes to its semiconductor products and services per JESD46, latest issue, and to discontinue any product or service per JESD48, latest issue. Buyers should obtain the latest relevant information before placing orders and should verify that such information is current and complete.

TI's published terms of sale for semiconductor products (<http://www.ti.com/sc/docs/stdterms.htm>) apply to the sale of packaged integrated circuit products that TI has qualified and released to market. Additional terms may apply to the use or sale of other types of TI products and services.

Reproduction of significant portions of TI information in TI data sheets is permissible only if reproduction is without alteration and is accompanied by all associated warranties, conditions, limitations, and notices. TI is not responsible or liable for such reproduced documentation. Information of third parties may be subject to additional restrictions. Resale of TI products or services with statements different from or beyond the parameters stated by TI for that product or service voids all express and any implied warranties for the associated TI product or service and is an unfair and deceptive business practice. TI is not responsible or liable for any such statements.

Buyers and others who are developing systems that incorporate TI products (collectively, "Designers") understand and agree that Designers remain responsible for using their independent analysis, evaluation and judgment in designing their applications and that Designers have full and exclusive responsibility to assure the safety of Designers' applications and compliance of their applications (and of all TI products used in or for Designers' applications) with all applicable regulations, laws and other applicable requirements. Designer represents that, with respect to their applications, Designer has all the necessary expertise to create and implement safeguards that (1) anticipate dangerous consequences of failures, (2) monitor failures and their consequences, and (3) lessen the likelihood of failures that might cause harm and take appropriate actions. Designer agrees that prior to using or distributing any applications that include TI products, Designer will thoroughly test such applications and the functionality of such TI products as used in such applications.

TI's provision of technical, application or other design advice, quality characterization, reliability data or other services or information, including, but not limited to, reference designs and materials relating to evaluation modules, (collectively, "TI Resources") are intended to assist designers who are developing applications that incorporate TI products; by downloading, accessing or using TI Resources in any way, Designer (individually or, if Designer is acting on behalf of a company, Designer's company) agrees to use any particular TI Resource solely for this purpose and subject to the terms of this Notice.

TI's provision of TI Resources does not expand or otherwise alter TI's applicable published warranties or warranty disclaimers for TI products, and no additional obligations or liabilities arise from TI providing such TI Resources. TI reserves the right to make corrections, enhancements, improvements and other changes to its TI Resources. TI has not conducted any testing other than that specifically described in the published documentation for a particular TI Resource.

Designer is authorized to use, copy and modify any individual TI Resource only in connection with the development of applications that include the TI product(s) identified in such TI Resource. NO OTHER LICENSE, EXPRESS OR IMPLIED, BY ESTOPPEL OR OTHERWISE TO ANY OTHER TI INTELLECTUAL PROPERTY RIGHT, AND NO LICENSE TO ANY TECHNOLOGY OR INTELLECTUAL PROPERTY RIGHT OF TI OR ANY THIRD PARTY IS GRANTED HEREIN, including but not limited to any patent right, copyright, mask work right, or other intellectual property right relating to any combination, machine, or process in which TI products or services are used. Information regarding or referencing third-party products or services does not constitute a license to use such products or services, or a warranty or endorsement thereof. Use of TI Resources may require a license from a third party under the patents or other intellectual property of the third party, or a license from TI under the patents or other intellectual property of TI.

TI RESOURCES ARE PROVIDED "AS IS" AND WITH ALL FAULTS. TI DISCLAIMS ALL OTHER WARRANTIES OR REPRESENTATIONS, EXPRESS OR IMPLIED, REGARDING RESOURCES OR USE THEREOF, INCLUDING BUT NOT LIMITED TO ACCURACY OR COMPLETENESS, TITLE, ANY EPIDEMIC FAILURE WARRANTY AND ANY IMPLIED WARRANTIES OF MERCHANTABILITY, FITNESS FOR A PARTICULAR PURPOSE, AND NON-INFRINGEMENT OF ANY THIRD PARTY INTELLECTUAL PROPERTY RIGHTS. TI SHALL NOT BE LIABLE FOR AND SHALL NOT DEFEND OR INDEMNIFY DESIGNER AGAINST ANY CLAIM, INCLUDING BUT NOT LIMITED TO ANY INFRINGEMENT CLAIM THAT RELATES TO OR IS BASED ON ANY COMBINATION OF PRODUCTS EVEN IF DESCRIBED IN TI RESOURCES OR OTHERWISE. IN NO EVENT SHALL TI BE LIABLE FOR ANY ACTUAL, DIRECT, SPECIAL, COLLATERAL, INDIRECT, PUNITIVE, INCIDENTAL, CONSEQUENTIAL OR EXEMPLARY DAMAGES IN CONNECTION WITH OR ARISING OUT OF TI RESOURCES OR USE THEREOF, AND REGARDLESS OF WHETHER TI HAS BEEN ADVISED OF THE POSSIBILITY OF SUCH DAMAGES.

Unless TI has explicitly designated an individual product as meeting the requirements of a particular industry standard (e.g., ISO/TS 16949 and ISO 26262), TI is not responsible for any failure to meet such industry standard requirements.

Where TI specifically promotes products as facilitating functional safety or as compliant with industry functional safety standards, such products are intended to help enable customers to design and create their own applications that meet applicable functional safety standards and requirements. Using products in an application does not by itself establish any safety features in the application. Designers must ensure compliance with safety-related requirements and standards applicable to their applications. Designer may not use any TI products in life-critical medical equipment unless authorized officers of the parties have executed a special contract specifically governing such use. Life-critical medical equipment is medical equipment where failure of such equipment would cause serious bodily injury or death (e.g., life support, pacemakers, defibrillators, heart pumps, neurostimulators, and implantables). Such equipment includes, without limitation, all medical devices identified by the U.S. Food and Drug Administration as Class III devices and equivalent classifications outside the U.S.

TI may expressly designate certain products as completing a particular qualification (e.g., Q100, Military Grade, or Enhanced Product). Designers agree that it has the necessary expertise to select the product with the appropriate qualification designation for their applications and that proper product selection is at Designers' own risk. Designers are solely responsible for compliance with all legal and regulatory requirements in connection with such selection.

Designer will fully indemnify TI and its representatives against any damages, costs, losses, and/or liabilities arising out of Designer's non-compliance with the terms and provisions of this Notice.

Looking for pricing, stock, or lifecycle information?

Click below to explore more details on WIN SOURCE:

 [View TPS75100YFFT on WIN SOURCE](#)

 [Texas Instruments](#) Information

Optimize Your Supply Chain with WIN SOURCE Solutions

-  Global Sourcing Solution
-  Obsolete Management
-  Cost Control Management
-  Shortage Management
-  Alternative Solution
-  Excess Inventory Management