

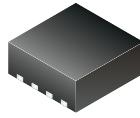

**THE DATASHEET OF
TPS51601ADRBT**





Dual High Efficiency Synchronous MOSFET Driver

Check for Samples: [TPS51601A](#)

FEATURES

- High Voltage Synchronous Buck Driver
- Integrated Boost Switch for Bootstrap Action
- Adaptive Dead Time Control and Shoot-through Protection
- 0.4-Ω Sink Resistance for Low-side Drive
- 1.0-Ω Source Resistance for High-side Drive
- SKIP Pin to Improve Light-Load Efficiency
- Adaptive Zero-Crossing Detection for Optimal Light-Load Efficiency
- 8-Pin 3 mm × 3 mm SON (DRB) Package

DESCRIPTION

The TPS51601A is a synchronous buck MOSFET driver with integrated boost switch. This high-performance driver is capable of driving high-side and low-side side N-channel FETs with the highest speed and lowest switching loss. Adaptive dead-time control and shoot-through protection are included.

The TPS51601A is available in the space-saving 8-pin 3 mm × 3 mm SON package and operates between -40°C and 105°C.

APPLICATIONS

- Mobile core regulator products
- High frequency DC-DC Converters
- High input voltage DC-DC converters
- Multiphase DC-DC converters

SIMPLIFIED APPLICATION

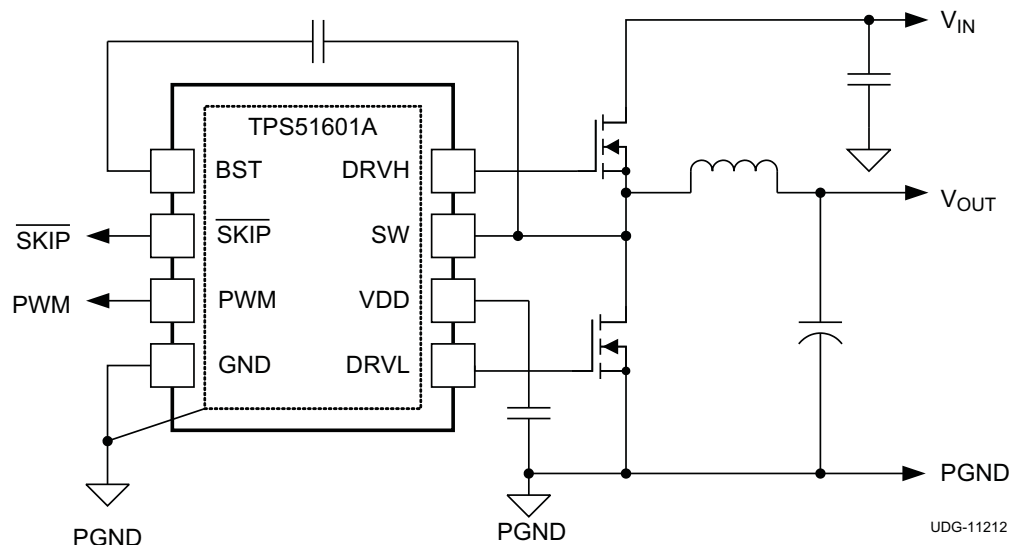

Please be aware that an important notice concerning availability, standard warranty, and use in critical applications of Texas Instruments semiconductor products and disclaimers thereto appears at the end of this data sheet.



These devices have limited built-in ESD protection. The leads should be shorted together or the device placed in conductive foam during storage or handling to prevent electrostatic damage to the MOS gates.

ORDERING INFORMATION⁽¹⁾⁽²⁾

T _A	PACKAGE	ORDERABLE NUMBER	PINS	TRANSPORT MEDIA	MINIMUM QUANTITY	ECO PLAN
-40°C to 105°C	Plastic Small Outline No-Lead (SON)	TPS51601ADRBT	8	Tape-and-reel (large)	250	Green (RoHS and no Sb/Br)
		TPS51601ADRBR		Tape-and-reel (small)	3000	

- (1) For the most current package and ordering information see the *Package Option Addendum* at the end of this document, or see the TI web site at www.ti.com.
- (2) Package drawings, thermal data, and symbolization are available at www.ti.com/packaging.

ABSOLUTE MAXIMUM RATINGS⁽¹⁾⁽²⁾⁽³⁾

		MIN	MAX	UNIT
Input voltage	VDD	-0.3	6	V
	PWM, $\overline{\text{SKIP}}$	-0.3	6	
Output voltages	BST to SW	-0.3	6	V
	DRVH to SW	-0.3	6	
	DRVL	-0.3	6	
	SW	-1	32	
Ground	GND	-0.3	0.3	V
Operating junction temperature, T _J		-40	125	°C
Storage temperature, T _{stg}		-55	150	°C

- (1) Stresses beyond those listed in this table may cause permanent damage to the device. These are stress ratings only and functional operation of the device at these or any other conditions beyond those indicated in the **RECOMMENDED OPERATING CONDITIONS** table is not implied. Exposure to absolute-maximum-rated conditions for extended periods may affect device reliability.
- (2) All voltage values are with respect to the network ground terminal unless otherwise noted.
- (3) Voltage values are with respect to the corresponding LL terminal.

THERMAL INFORMATION

THERMAL METRIC ⁽¹⁾		TPS51601	UNITS
		DRB	
		8 PINS	
θ_{JA}	Junction-to-ambient thermal resistance ⁽²⁾	42.6	°C/W
θ_{Jctop}	Junction-to-case (top) thermal resistance ⁽³⁾	3.0	
θ_{JB}	Junction-to-board thermal resistance ⁽⁴⁾	18.9	
Ψ_{JT}	Junction-to-top characterization parameter ⁽⁵⁾	62.1	
Ψ_{JB}	Junction-to-board characterization parameter ⁽⁶⁾	19.1	
θ_{Jcbot}	Junction-to-case (bottom) thermal resistance ⁽⁷⁾	12.7	

- (1) For more information about traditional and new thermal metrics, see the *IC Package Thermal Metrics* application report, [SPRA953](#).
- (2) The junction-to-ambient thermal resistance under natural convection is obtained in a simulation on a JEDEC-standard, high-K board, as specified in JESD51-7, in an environment described in JESD51-2a.
- (3) The junction-to-case (top) thermal resistance is obtained by simulating a cold plate test on the package top. No specific JEDEC-standard test exists, but a close description can be found in the ANSI SEMI standard G30-88.
- (4) The junction-to-board thermal resistance is obtained by simulating in an environment with a ring cold plate fixture to control the PCB temperature, as described in JESD51-8.
- (5) The junction-to-top characterization parameter, Ψ_{JT} , estimates the junction temperature of a device in a real system and is extracted from the simulation data for obtaining θ_{JA} , using a procedure described in JESD51-2a (sections 6 and 7).
- (6) The junction-to-board characterization parameter, Ψ_{JB} , estimates the junction temperature of a device in a real system and is extracted from the simulation data for obtaining θ_{JA} , using a procedure described in JESD51-2a (sections 6 and 7).
- (7) The junction-to-case (bottom) thermal resistance is obtained by simulating a cold plate test on the exposed (power) pad. No specific JEDEC standard test exists, but a close description can be found in the ANSI SEMI standard G30-88.

RECOMMENDED OPERATING CONDITIONS

		MIN	TYP	MAX	UNIT
Input voltages	VDD	4.5		5.5	V
	PWM, $\overline{\text{SKIP}}$	-0.1		5.5	
Output voltages	BST to SW	-0.1		5.5	V
	DRVH to SW	-0.1		5.5	
	DRVL	-0.1		5.5	
	SW	-1		30	
Ground	GND	-0.1		0.1	V
Operating junction temperature, T _J		-40		105	°C

ELECTRICAL CHARACTERISTICS

over operating free-air temperature range, $V_{DD} = 5.0$ V (unless otherwise noted)

PARAMETER		CONDITIONS	MIN	TYP	MAX	UNIT	
SUPPLY, UNDERVOLTAGE LOCKOUT							
I_{VDD}	VDD bias current	PWM = HI		160	220	μ A	
		PWM = LO		500			
		PWM = float		50			
$V_{UVLO(h)}$	VDD UVLO 'OK' threshold		3.5	3.7	3.9	V	
$V_{UVLO(l)}$	VDD UVLO fault threshold		3.3	3.5	3.7	V	
$V_{UVLO(hys)}$	VDD UVLO hysteresis			0.2		V	
PWM INPUT							
$V_{IH(pwm)}$	HIGH-level PWM input		4.0			V	
$V_{IL(pwm)}$	LOW-level PWM input				0.7	V	
$R_{VDD-PWM}$	VDD-to-PWM resistance			30		k Ω	
$R_{PWM-GND}$	PWM-to-GND resistance			20		k Ω	
$V_{PWM(tri)}$	PWM tri-state voltage	PWM floating	1.5		2.5	V	
SKIP INPUT							
$V_{IH(skip)}$	HIGH-level \overline{SKIP} input logic		2.2			V	
$V_{IL(\overline{skip})}$	LOW-level \overline{SKIP} input logic				0.7	V	
$I_{L\overline{SKIP-GND}}$	\overline{SKIP} -to-GND leakage	$V_{\overline{SKIP}} = 5$ V			2	μ A	
GATE DRIVE OUTPUT							
R_{DRVH}	DRVH on resistance	Source resistance, $(V_{BST} - V_{LL}) = 5$ V, HIGH-state $(V_{BST} - V_{DRVH}) = 0.1$ V		1.0	2.5	Ω	
		Sink resistance, $(V_{BST} - V_{LL}) = 5$ V, LOW-state $(V_{DRVH} - V_{LL}) = 0.1$ V		0.5	1.5		
R_{DRVL}	DRVL on resistance	Source resistance, $(V_{VDD} - GND) = 5$ V, HIGH-state, $V_{VDD} - V_{DRVL} = 0.1$ V		0.8	1.5	Ω	
		Sink resistance, $V_{VDD} - GND = 5$ V LOW-state, $V_{DRVL} - GND = 0.1$ V		0.4	1.0		
TIMING CHARACTERISTICS							
t_{DRVH}	DRVH transition time	DRVH rising, $C_{DRVH} = 3.3$ nF		15	35	ns	
		DRVH falling, $C_{DRVH} = 3.3$ nF		10	35		
t_{DRVL}	DRVL transition time	DRVL rising, $C_{DRVL} = 3.3$ nF		15	35	ns	
		DRVL, falling, $C_{DRVL} = 3.3$ nF		10	35		
$t_{NONOVL P}$	Driver non-overlap time	DRVH LOW to DRVL HIGH		5	20	ns	
		DRVL LOW to DRVH HIGH		5	20		
$t_{DLY(ri se)}$	PWM rising to drive output delay	DCM mode: PWM rising to DRVH rising		25		ns	
		CCM mode: PWM rising to DRVL falling		25			
$t_{DLY(fall)}$	PWM falling to drive output delay	PWM falling to DRVH falling		25		ns	
t_{DLY1}	3-state propagation delay to LOW	PWM floating to PWM LOW		40		ns	
t_{DLY2}	3-state propagation delay to HIGH	PWM floating to PWM HIGH		50		ns	
$t_{TS(hold)}$	3-state hold-off time	PWM entering tri-state from HIGH or LOW		150		ns	
$t_{\overline{SKIP}(pdh)}$	\overline{SKIP} LOW-to-HIGH propagation delay			15		ns	
$t_{\overline{SKIP}(pdl)}$	\overline{SKIP} HIGH-to-LOW propagation delay			15		ns	
$t_{DRVH(min)}$	Minimum DRVH width				80	ns	
$t_{DRVL(min)}$	Minimum DRVL width	Minimum DRVL width before Zero-crossing can turn OFF DRVL		400	500	ns	
BOOT-STRAP SWITCH (BST)							
R_{BST}	BST switch on-resistance	$I_{BST} = 10$ mA		4	10	20	Ω
$I_{BST(leak)}$	BST switch leakage current	$V_{BST} = 34$ V, $V_{SW} = 28$ V				2	μ A

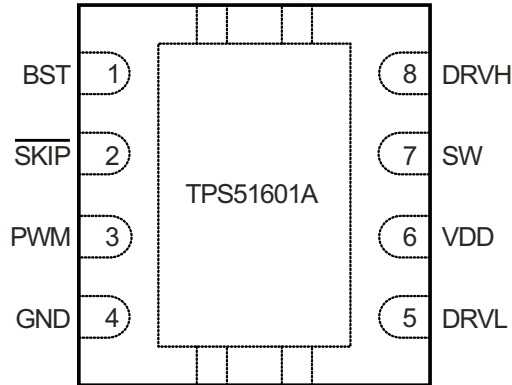
DEVICE INFORMATION
**QFN (DRB) PACKAGE
8 PINS
(TOP VIEW)**

PIN FUNCTIONS

PIN NAME	I/O	DESCRIPTION
BST	I	High-side, N-channel FET bootstrap voltage input, supply for high-side driver
DRVH	O	High-side, N-channel FET gate drive output.
DRVL	O	Low-side, synchronous N-channel FET gate drive output
GND	–	Low-side, synchronous N-channel FET gate drive return and device ground.
PWM	I	PWM input. This defines the on-time for the high-side FET of the converter. Input is coming from PWM controller. A 3-state voltage on this pin turns OFF both the high-side (DRVH) and low-side drivers (DRVL)
PwrPAD	–	Thermal pad. This is a non-electrical pad and is recommended to be connected to GND.
$\overline{\text{SKIP}}$	I	If $\overline{\text{SKIP}}$ is LOW, then the inductor current zero-crossing is active and DRVH turns off when inductor current goes to zero. (discontinuous conduction mode active) If $\overline{\text{SKIP}}$ is HIGH, then the DRVH stays HIGH as long as PWM stays LOW. (forced continuous conduction mode)
SW	I/O	High-side N-channel FET gate drive return. Also used as input for sensing inductor current for zero-crossing.
VDD	I	5-V power supply input for the device.

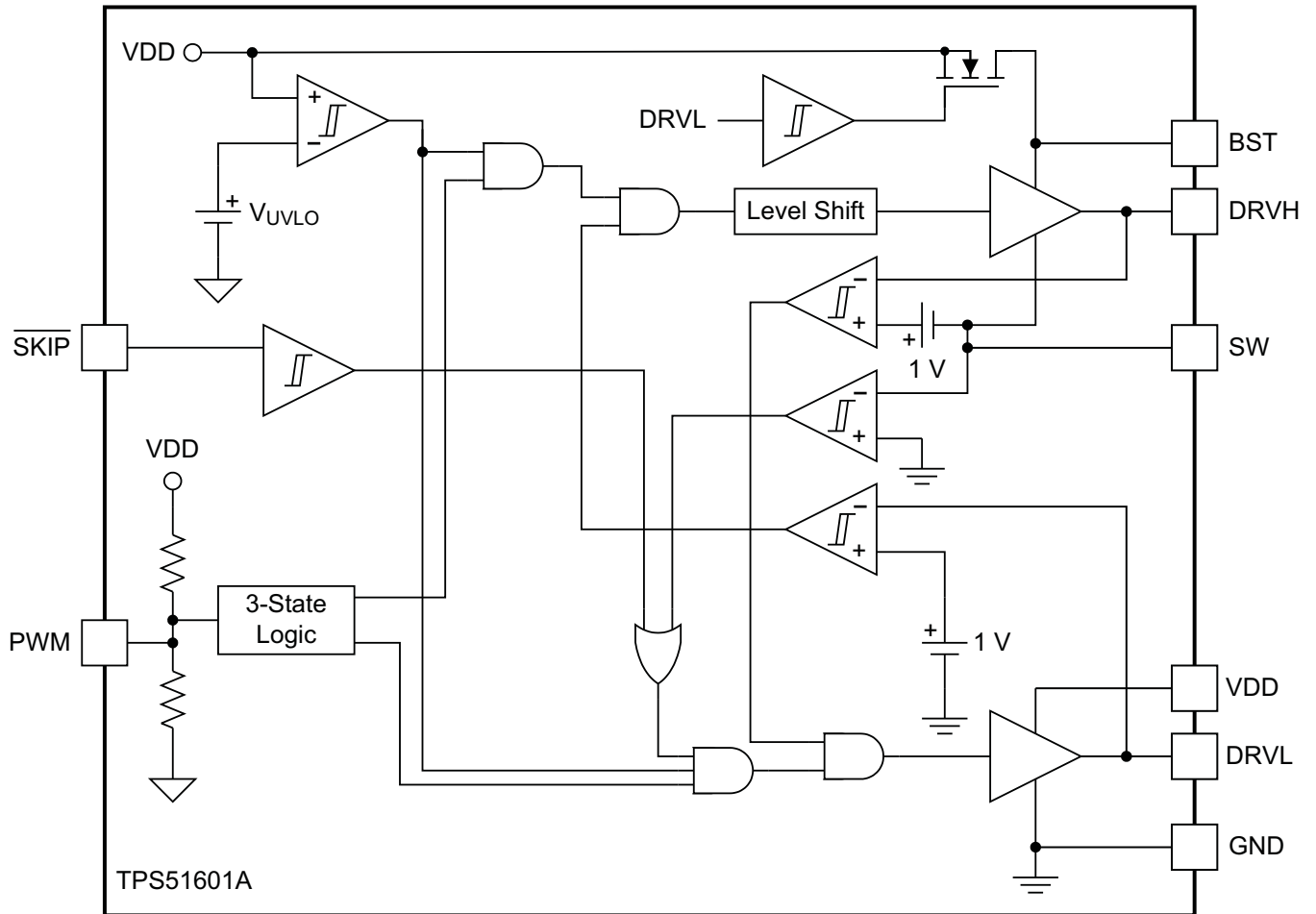
FUNCTIONAL BLOCK DIAGRAM



UDG-11213

TYPICAL CHARACTERISTICS

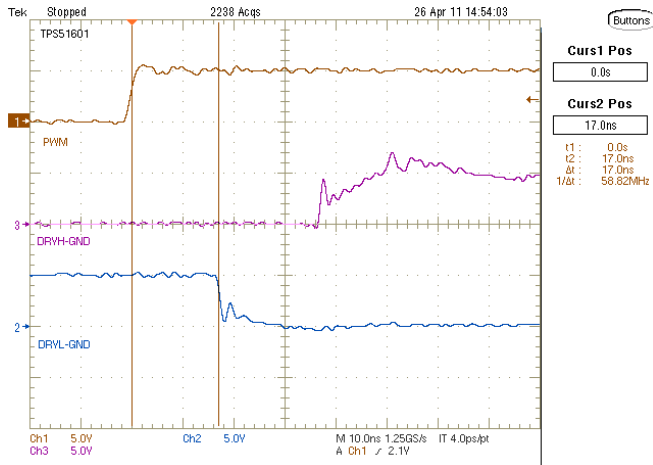

Figure 1. PWM Rising to DRVL Falling

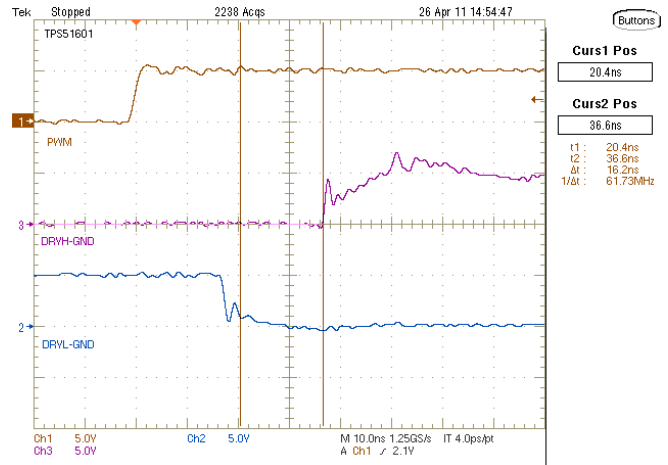

Figure 2. DRVL Falling to DRVH rising

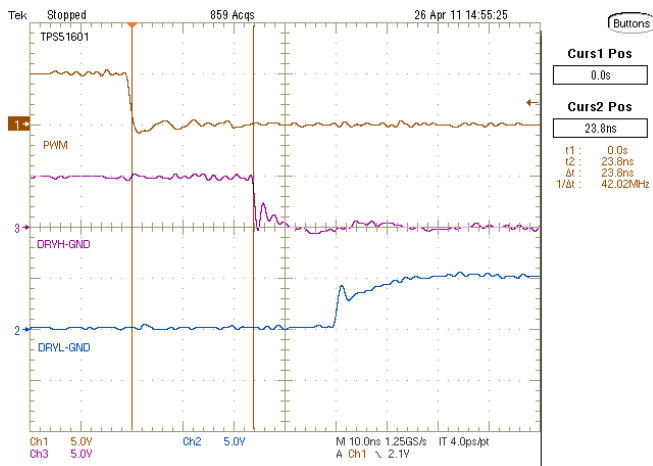

Figure 3. PWM Falling to DRVH Falling

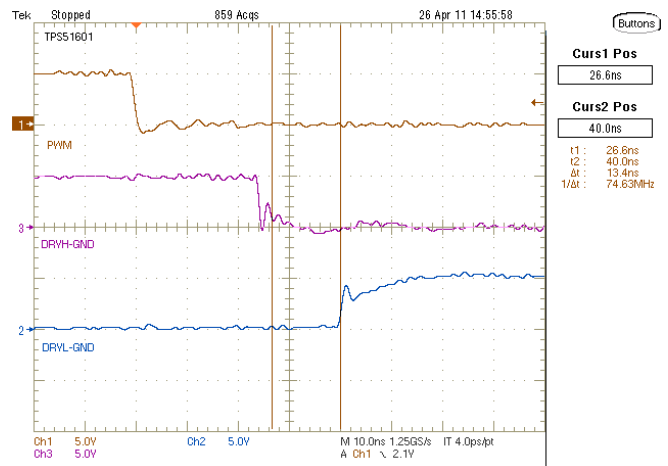

Figure 4. SW-Node Falling to DRVL Rising

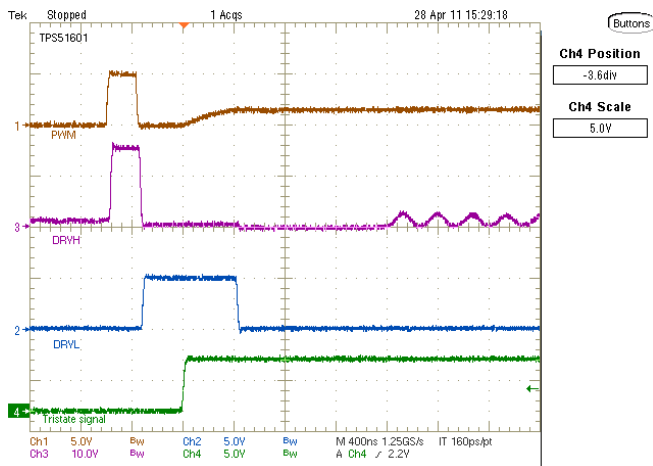

Figure 5. 3-State Entry on DRVL

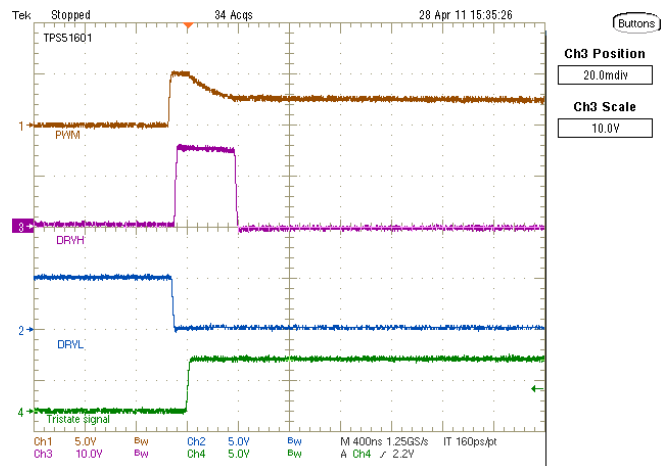

Figure 6. 3-State Entry on DRVH

TYPICAL CHARACTERISTICS (continued)

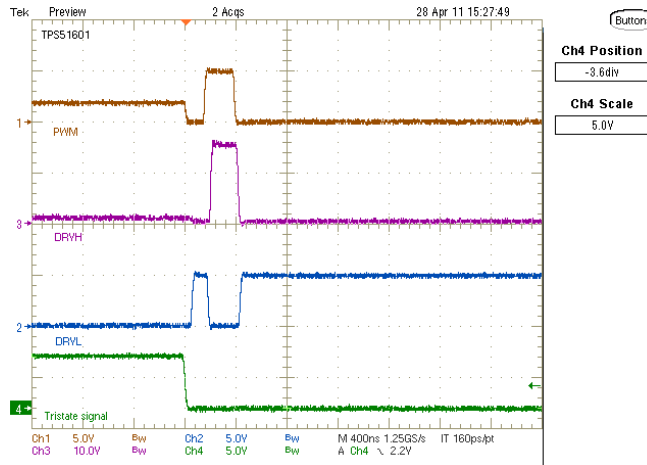

Figure 7. 3-State Exit on DRVL

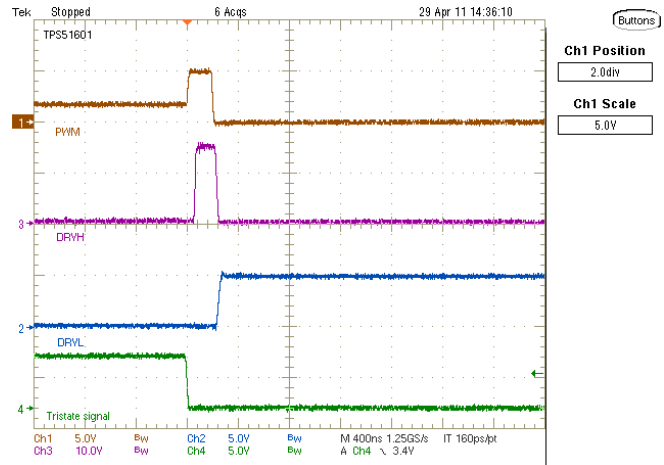

Figure 8. 3-State Exit on DRVH

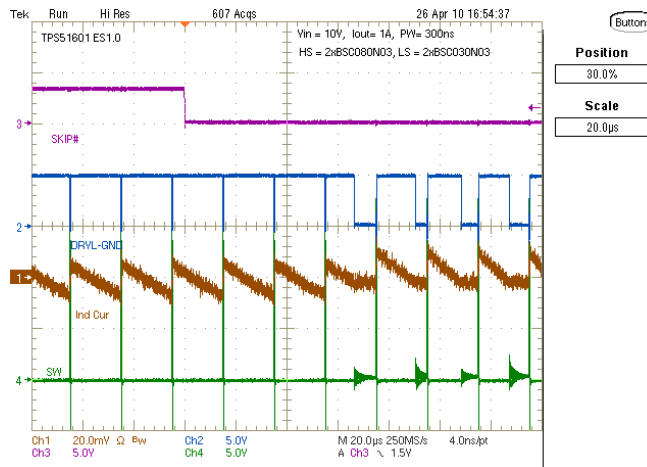

Figure 9. FCCM Exit and SKIP Mode Entry

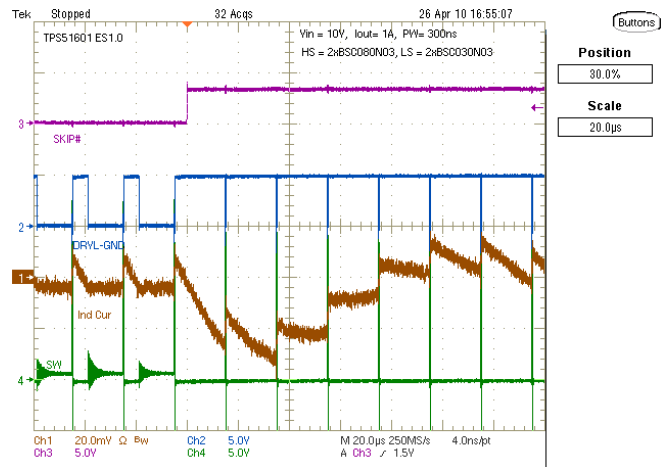

Figure 10. SKIP Mode Exit and FCCM Entry

TYPICAL CHARACTERISTICS

For Figure 11 through Figure 16 high-side FET used is CSD17302Q5A and low-side FET used is CSD17303Q5.

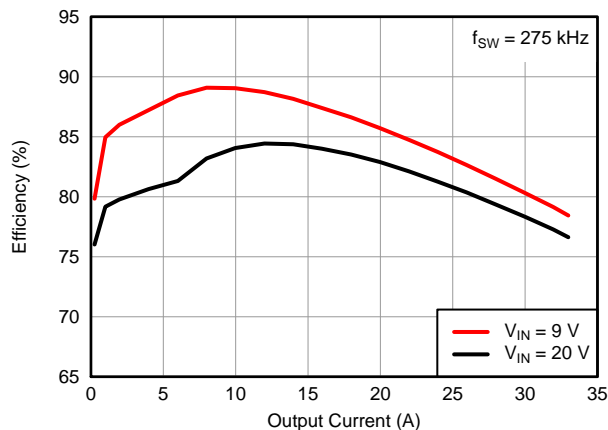

Figure 11. Efficiency vs. Output Current

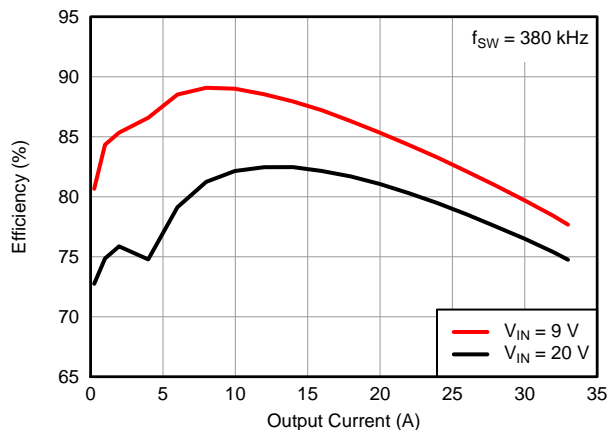

Figure 12. Efficiency vs. Output Current

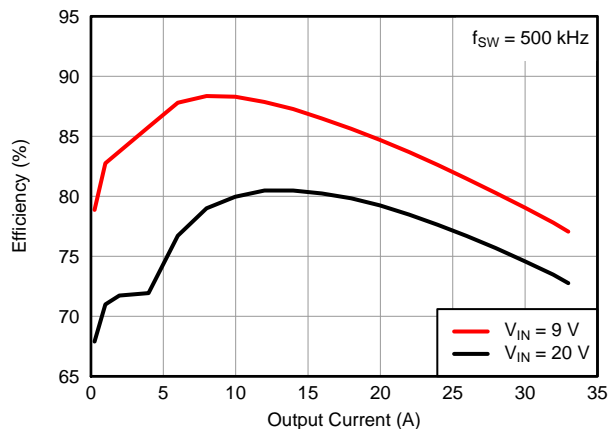

Figure 13. Efficiency vs. Output Current

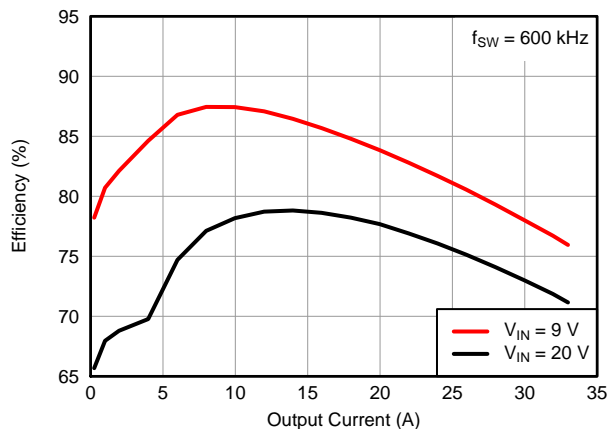

Figure 14. Efficiency vs. Output Current

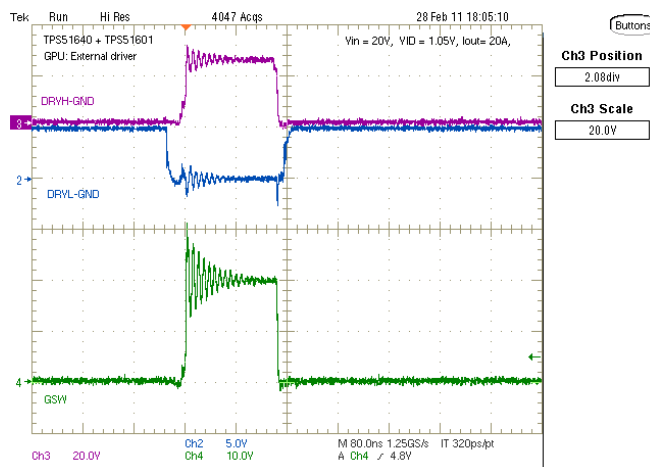

Figure 15. Gate Driver Waveforms Using TPS51640 Controller and TPS51601A Driver at $V_{IN} = 9\text{ V}$

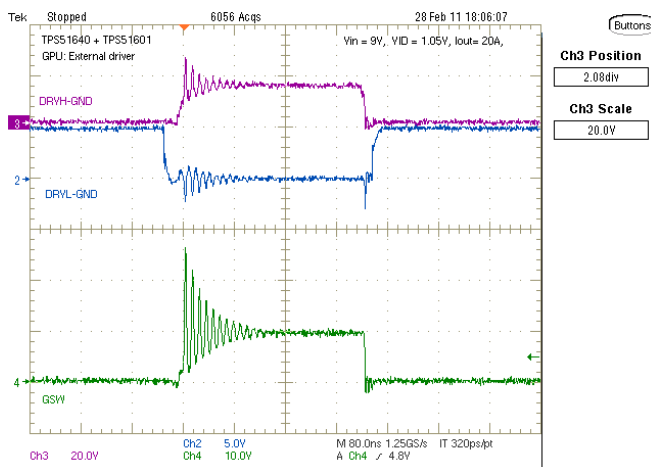

Figure 16. Gate Driver Waveforms Using TPS51640 Controller and TPS51601A Driver at $V_{IN} = 20\text{ V}$

DETAILED DESCRIPTION

UVLO

The TPS51601A includes an undervoltage lockout circuit that disables the driver and external power FETs in an OFF state when the input supply voltage, (V_{VDD}) is insufficient to drive external power FET reliably. During the power-up sequence, both gate drive outputs remain low until the VDD voltage reaches UVLO-H threshold, typically 3.7 V. Once the UVLO threshold is reached, the condition of the gate drive outputs is defined by the input PWM and SKIP signals. During the power-down sequence, the UVLO threshold is set lower, typically 3.5 V.

PWM Input

Once the input supply voltage is above the UVLO threshold, the gate drive outputs are defined by the PWM input and $\overline{\text{SKIP}}$ input. Prior to PWM going HIGH, both the gate drive outputs, (DRVH and DRVL) are held LOW. The DRVL is LOW until the first PWM HIGH pulse to support pre-biased start-up. Once PWM goes HIGH for the first time, DRVH goes HIGH. Then, when PWM goes LOW, DRVH goes LOW first. After the non-overlap time, DRVL goes HIGH.

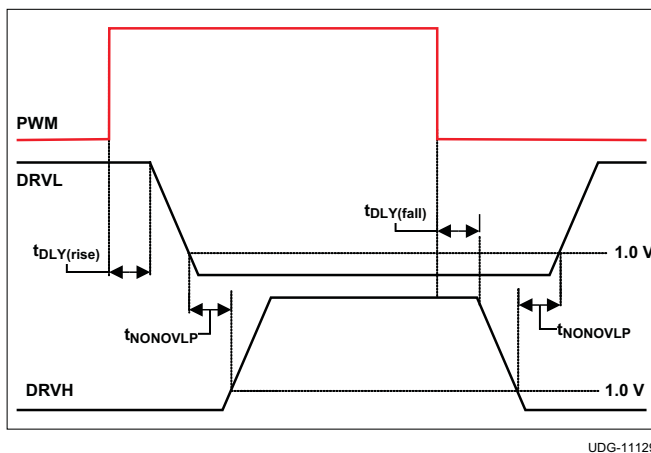

Figure 17. Continuous Conduction Mode Waveforms

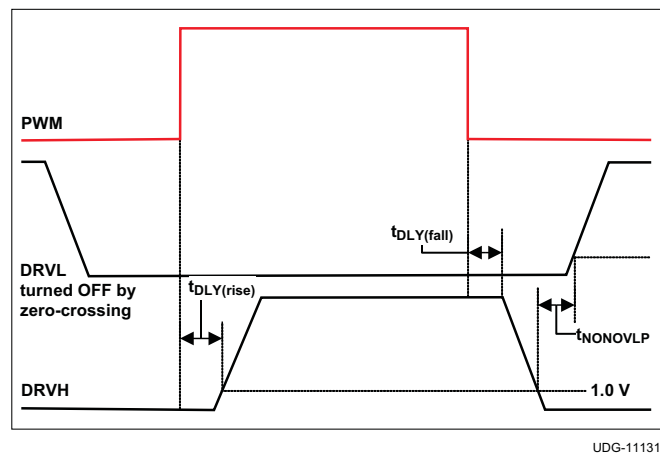

Figure 18. Discontinuous Conduction Mode Waveforms

SKIP/FCCM Mode Operation

The TPS51601A can be configured in two ways. When used as the external driver for Phase 1, this pin connects to the corresponding SKIP pin of the PWM controller. The SKIP pin is active low signal. This means when SKIP is low, then the zero crossing detection circuit of the driver is active. When SKIP is high, the zero-crossing detector is disabled and the converter operates in forced continuous conduction mode (FCCM).

Adaptive Zero-Crossing

The TPS51601A has an adaptive zero-crossing detector. Zero crossing accuracy is detected by checking the switch-node voltage at an appropriate time after the low-side FET is turned OFF by DRVL going low. Then the zero-crossing comparator offset is updated based on previous result. After several zero-crossing events, the comparator offset is optimized to give the best efficiency.

Adaptive Dead-Time Control (Anti-Cross Conduction)

The TPS51601A has an adaptive dead-time control logic to minimize the non-overlap time between DRVH and DRVL signals. The internal signal to the low-side driver goes HIGH only when the DRVH-SW voltage goes below approximately 1 V and DRVH goes below approximately 1 V to ensure the high-side MOSFET has turned OFF. Additional driver delays ensure that there is some non-overlap time between DRVH falling edge and DRVL rising edge. Similarly, the internal signal to the DRVH goes high only after DRVL-GND goes below 1 V.

Integrated Boost-Switch

To maintain a BST-SW voltage close to VDD (to get lower conduction losses on the high-side FET), the conventional diode from VDD to BST is replaced by a FET which is gated by DRVL signal.

APPLICATION INFORMATION

Figure 19 shows a typical application. Resistors R1 and R2 can be used if necessary to reduce the switch-node ringing.

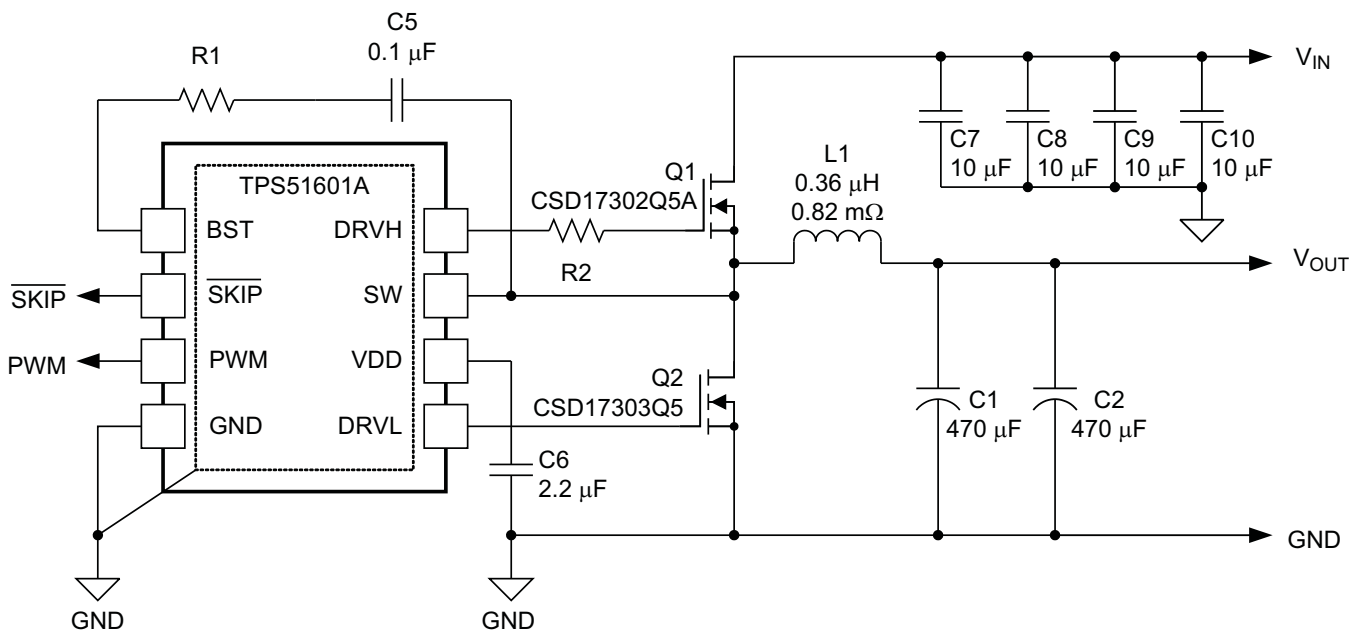

UDG-11214

Figure 19. Typical Application

PCB Layout Guidelines

Figure 20 shows the primary current loops in each phase, numbered in order of importance. The most important loop to minimize the area of is Loop 1, the path from the input capacitor through the high-side and low-side FETs, and back to the capacitor through ground. Loop 2 is from the inductor through the output capacitor, ground and Q2. The layout of the low side gate drive (loops 3a and 3b) is important. The guidelines for gate drive layout are:

- Make the low-side gate drive as short as possible (1 inch or less preferred).
- Make the DRVL width to length ratio of 1:10, wider (1:5) if possible.
- If changing layers is necessary, use at least two vias.
- Decouple VDD to GND (C_D in Figure 20) with at ceramic capacitor with a value of least a 2.2- μ F.

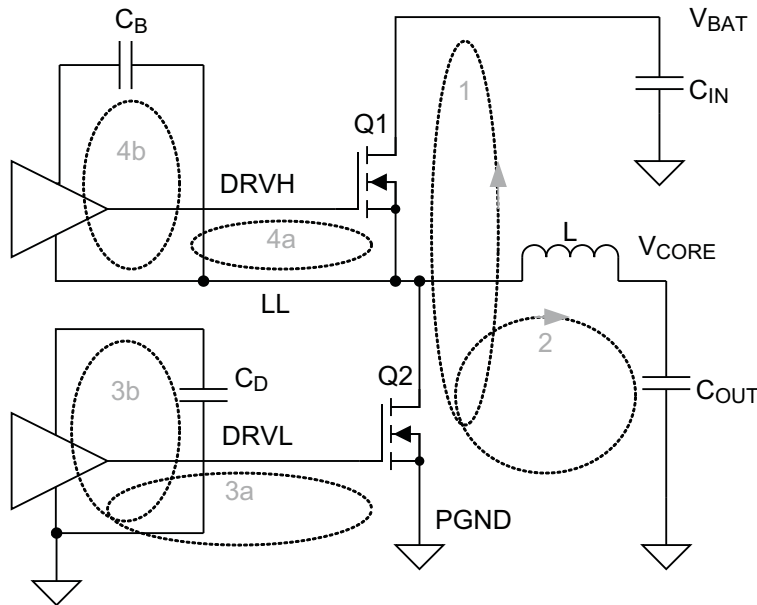

UDG-11040

Figure 20. Minimizing Current Loops

PACKAGING INFORMATION

Orderable Device	Status (1)	Package Type	Package Drawing	Pins	Package Qty	Eco Plan (2)	Lead/Ball Finish	MSL Peak Temp (3)	Op Temp (°C)	Top-Side Markings (4)	Samples
TPS51601ADRBR	ACTIVE	SON	DRB	8	3000	Green (RoHS & no Sb/Br)	CU NIPDAU	Level-2-260C-1 YEAR	-40 to 105	601A	Samples
TPS51601ADRBT	ACTIVE	SON	DRB	8	250	Green (RoHS & no Sb/Br)	CU NIPDAU	Level-2-260C-1 YEAR	-40 to 105	601A	Samples

(1) The marketing status values are defined as follows:

ACTIVE: Product device recommended for new designs.

LIFEBUY: TI has announced that the device will be discontinued, and a lifetime-buy period is in effect.

NRND: Not recommended for new designs. Device is in production to support existing customers, but TI does not recommend using this part in a new design.

PREVIEW: Device has been announced but is not in production. Samples may or may not be available.

OBSOLETE: TI has discontinued the production of the device.

(2) Eco Plan - The planned eco-friendly classification: Pb-Free (RoHS), Pb-Free (RoHS Exempt), or Green (RoHS & no Sb/Br) - please check <http://www.ti.com/productcontent> for the latest availability information and additional product content details.

TBD: The Pb-Free/Green conversion plan has not been defined.

Pb-Free (RoHS): TI's terms "Lead-Free" or "Pb-Free" mean semiconductor products that are compatible with the current RoHS requirements for all 6 substances, including the requirement that lead not exceed 0.1% by weight in homogeneous materials. Where designed to be soldered at high temperatures, TI Pb-Free products are suitable for use in specified lead-free processes.

Pb-Free (RoHS Exempt): This component has a RoHS exemption for either 1) lead-based flip-chip solder bumps used between the die and package, or 2) lead-based die adhesive used between the die and leadframe. The component is otherwise considered Pb-Free (RoHS compatible) as defined above.

Green (RoHS & no Sb/Br): TI defines "Green" to mean Pb-Free (RoHS compatible), and free of Bromine (Br) and Antimony (Sb) based flame retardants (Br or Sb do not exceed 0.1% by weight in homogeneous material)

(3) MSL, Peak Temp. -- The Moisture Sensitivity Level rating according to the JEDEC industry standard classifications, and peak solder temperature.

(4) Multiple Top-Side Markings will be inside parentheses. Only one Top-Side Marking contained in parentheses and separated by a "~" will appear on a device. If a line is indented then it is a continuation of the previous line and the two combined represent the entire Top-Side Marking for that device.

Important Information and Disclaimer: The information provided on this page represents TI's knowledge and belief as of the date that it is provided. TI bases its knowledge and belief on information provided by third parties, and makes no representation or warranty as to the accuracy of such information. Efforts are underway to better integrate information from third parties. TI has taken and continues to take reasonable steps to provide representative and accurate information but may not have conducted destructive testing or chemical analysis on incoming materials and chemicals. TI and TI suppliers consider certain information to be proprietary, and thus CAS numbers and other limited information may not be available for release.

In no event shall TI's liability arising out of such information exceed the total purchase price of the TI part(s) at issue in this document sold by TI to Customer on an annual basis.

TAPE AND REEL INFORMATION

QUADRANT ASSIGNMENTS FOR PIN 1 ORIENTATION IN TAPE

*All dimensions are nominal

Device	Package Type	Package Drawing	Pins	SPQ	Reel Diameter (mm)	Reel Width W1 (mm)	A0 (mm)	B0 (mm)	K0 (mm)	P1 (mm)	W (mm)	Pin1 Quadrant
TPS51601ADRBR	SON	DRB	8	3000	330.0	12.4	3.3	3.3	1.1	8.0	12.0	Q2
TPS51601ADRBT	SON	DRB	8	250	180.0	12.4	3.3	3.3	1.1	8.0	12.0	Q2

TAPE AND REEL BOX DIMENSIONS

*All dimensions are nominal

Device	Package Type	Package Drawing	Pins	SPQ	Length (mm)	Width (mm)	Height (mm)
TPS51601ADRBR	SON	DRB	8	3000	367.0	367.0	35.0
TPS51601ADRBT	SON	DRB	8	250	210.0	185.0	35.0

DRB 8

GENERIC PACKAGE VIEW

VSON - 1 mm max height

PLASTIC SMALL OUTLINE - NO LEAD

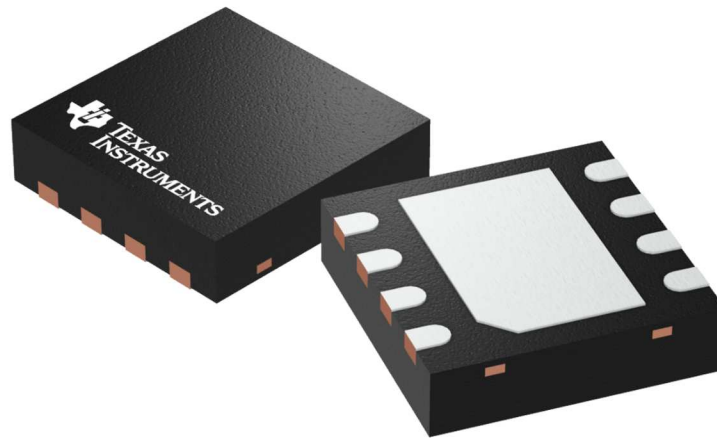

Images above are just a representation of the package family, actual package may vary.
Refer to the product data sheet for package details.

4203482/L

DRB0008B

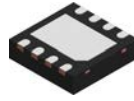

PACKAGE OUTLINE

VSON - 1 mm max height

PLASTIC SMALL OUTLINE - NO LEAD

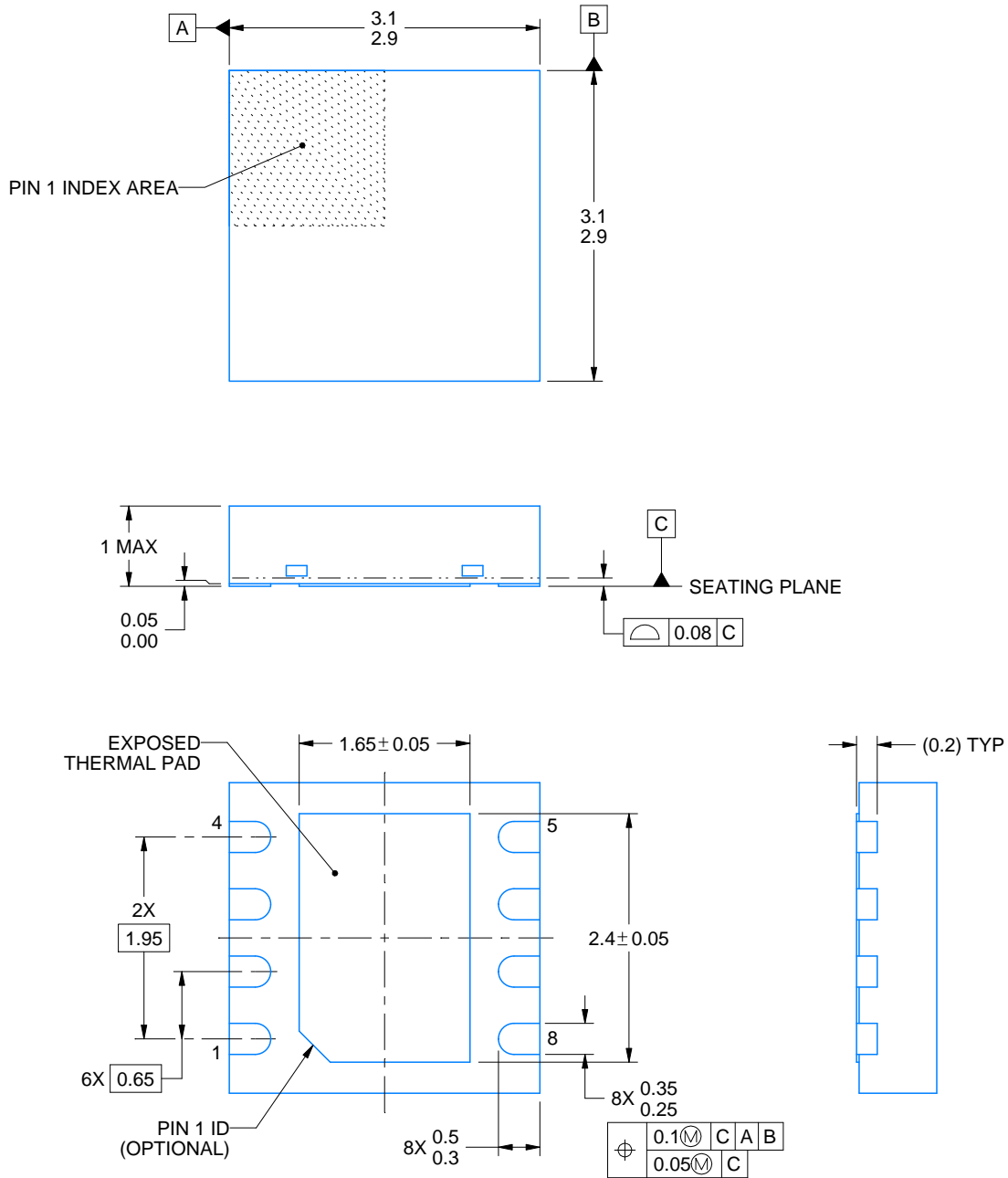

4218876/A 12/2017

NOTES:

1. All linear dimensions are in millimeters. Any dimensions in parenthesis are for reference only. Dimensioning and tolerancing per ASME Y14.5M.
2. This drawing is subject to change without notice.
3. The package thermal pad must be soldered to the printed circuit board for thermal and mechanical performance.

EXAMPLE BOARD LAYOUT

DRB0008B

VSON - 1 mm max height

PLASTIC SMALL OUTLINE - NO LEAD

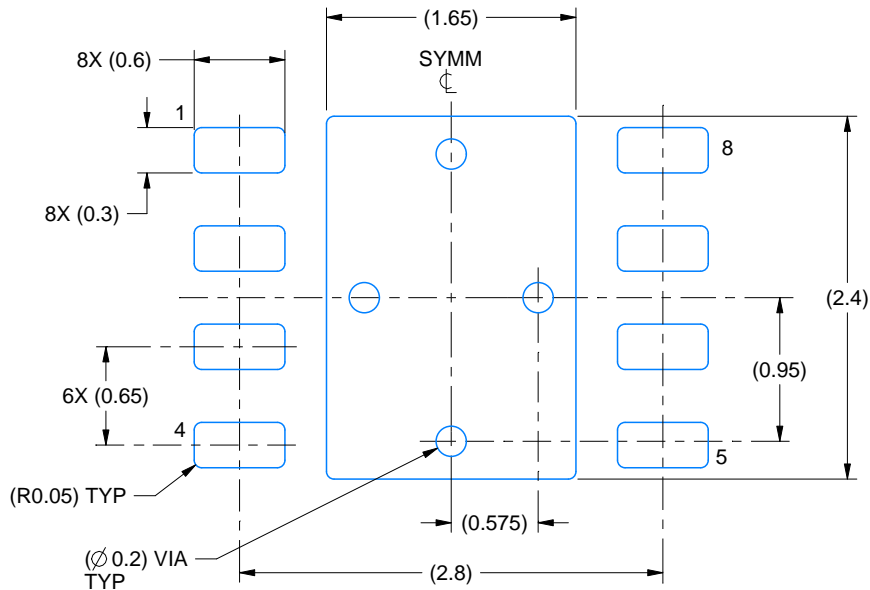

LAND PATTERN EXAMPLE
SCALE:20X

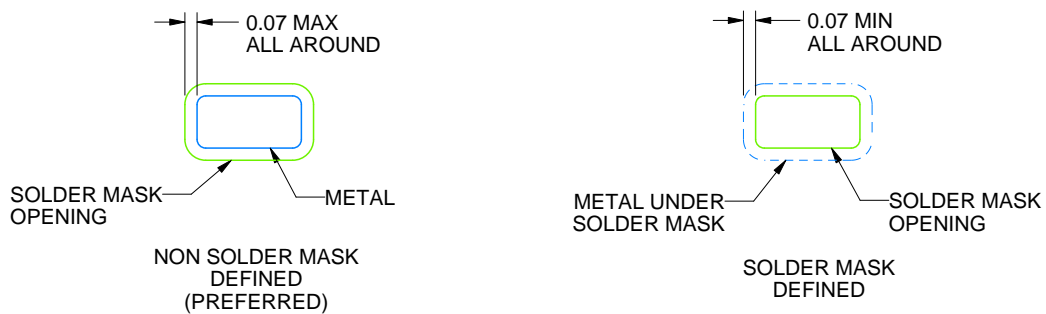

SOLDER MASK DETAILS

4218876/A 12/2017

NOTES: (continued)

4. This package is designed to be soldered to a thermal pad on the board. For more information, see Texas Instruments literature number SLUA271 (www.ti.com/lit/sluea271).
5. Vias are optional depending on application, refer to device data sheet. If any vias are implemented, refer to their locations shown on this view. It is recommended that vias under paste be filled, plugged or tented.

EXAMPLE STENCIL DESIGN

DRB0008B

VSON - 1 mm max height

PLASTIC SMALL OUTLINE - NO LEAD

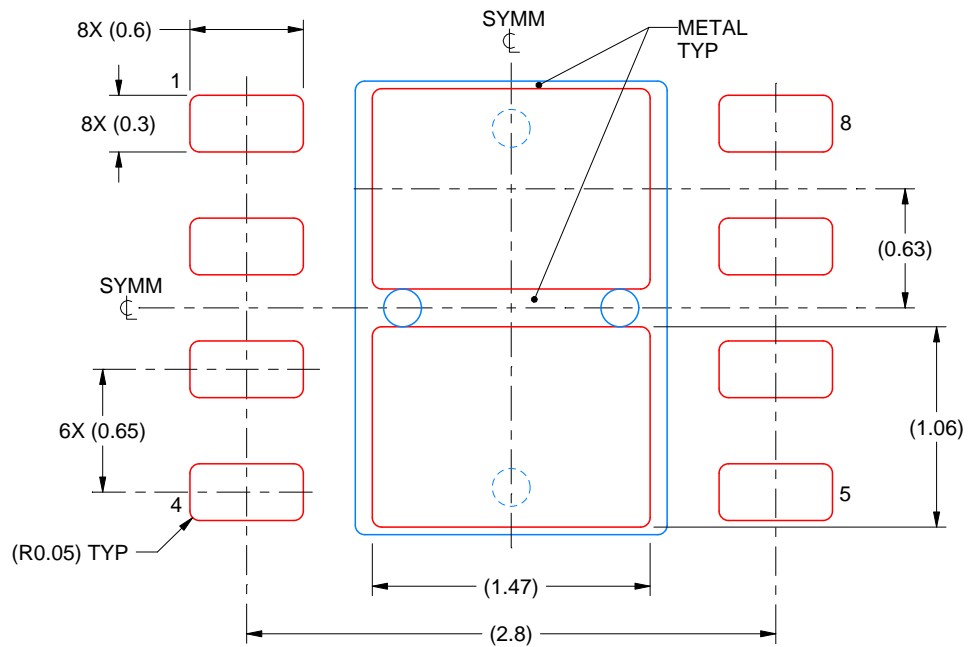

SOLDER PASTE EXAMPLE
BASED ON 0.125 mm THICK STENCIL

EXPOSED PAD
81% PRINTED SOLDER COVERAGE BY AREA
SCALE:25X

4218876/A 12/2017

NOTES: (continued)

6. Laser cutting apertures with trapezoidal walls and rounded corners may offer better paste release. IPC-7525 may have alternate design recommendations.

IMPORTANT NOTICE

Texas Instruments Incorporated (TI) reserves the right to make corrections, enhancements, improvements and other changes to its semiconductor products and services per JESD46, latest issue, and to discontinue any product or service per JESD48, latest issue. Buyers should obtain the latest relevant information before placing orders and should verify that such information is current and complete.

TI's published terms of sale for semiconductor products (<http://www.ti.com/sc/docs/stdterms.htm>) apply to the sale of packaged integrated circuit products that TI has qualified and released to market. Additional terms may apply to the use or sale of other types of TI products and services.

Reproduction of significant portions of TI information in TI data sheets is permissible only if reproduction is without alteration and is accompanied by all associated warranties, conditions, limitations, and notices. TI is not responsible or liable for such reproduced documentation. Information of third parties may be subject to additional restrictions. Resale of TI products or services with statements different from or beyond the parameters stated by TI for that product or service voids all express and any implied warranties for the associated TI product or service and is an unfair and deceptive business practice. TI is not responsible or liable for any such statements.

Buyers and others who are developing systems that incorporate TI products (collectively, "Designers") understand and agree that Designers remain responsible for using their independent analysis, evaluation and judgment in designing their applications and that Designers have full and exclusive responsibility to assure the safety of Designers' applications and compliance of their applications (and of all TI products used in or for Designers' applications) with all applicable regulations, laws and other applicable requirements. Designer represents that, with respect to their applications, Designer has all the necessary expertise to create and implement safeguards that (1) anticipate dangerous consequences of failures, (2) monitor failures and their consequences, and (3) lessen the likelihood of failures that might cause harm and take appropriate actions. Designer agrees that prior to using or distributing any applications that include TI products, Designer will thoroughly test such applications and the functionality of such TI products as used in such applications.

TI's provision of technical, application or other design advice, quality characterization, reliability data or other services or information, including, but not limited to, reference designs and materials relating to evaluation modules, (collectively, "TI Resources") are intended to assist designers who are developing applications that incorporate TI products; by downloading, accessing or using TI Resources in any way, Designer (individually or, if Designer is acting on behalf of a company, Designer's company) agrees to use any particular TI Resource solely for this purpose and subject to the terms of this Notice.

TI's provision of TI Resources does not expand or otherwise alter TI's applicable published warranties or warranty disclaimers for TI products, and no additional obligations or liabilities arise from TI providing such TI Resources. TI reserves the right to make corrections, enhancements, improvements and other changes to its TI Resources. TI has not conducted any testing other than that specifically described in the published documentation for a particular TI Resource.

Designer is authorized to use, copy and modify any individual TI Resource only in connection with the development of applications that include the TI product(s) identified in such TI Resource. NO OTHER LICENSE, EXPRESS OR IMPLIED, BY ESTOPPEL OR OTHERWISE TO ANY OTHER TI INTELLECTUAL PROPERTY RIGHT, AND NO LICENSE TO ANY TECHNOLOGY OR INTELLECTUAL PROPERTY RIGHT OF TI OR ANY THIRD PARTY IS GRANTED HEREIN, including but not limited to any patent right, copyright, mask work right, or other intellectual property right relating to any combination, machine, or process in which TI products or services are used. Information regarding or referencing third-party products or services does not constitute a license to use such products or services, or a warranty or endorsement thereof. Use of TI Resources may require a license from a third party under the patents or other intellectual property of the third party, or a license from TI under the patents or other intellectual property of TI.

TI RESOURCES ARE PROVIDED "AS IS" AND WITH ALL FAULTS. TI DISCLAIMS ALL OTHER WARRANTIES OR REPRESENTATIONS, EXPRESS OR IMPLIED, REGARDING RESOURCES OR USE THEREOF, INCLUDING BUT NOT LIMITED TO ACCURACY OR COMPLETENESS, TITLE, ANY EPIDEMIC FAILURE WARRANTY AND ANY IMPLIED WARRANTIES OF MERCHANTABILITY, FITNESS FOR A PARTICULAR PURPOSE, AND NON-INFRINGEMENT OF ANY THIRD PARTY INTELLECTUAL PROPERTY RIGHTS. TI SHALL NOT BE LIABLE FOR AND SHALL NOT DEFEND OR INDEMNIFY DESIGNER AGAINST ANY CLAIM, INCLUDING BUT NOT LIMITED TO ANY INFRINGEMENT CLAIM THAT RELATES TO OR IS BASED ON ANY COMBINATION OF PRODUCTS EVEN IF DESCRIBED IN TI RESOURCES OR OTHERWISE. IN NO EVENT SHALL TI BE LIABLE FOR ANY ACTUAL, DIRECT, SPECIAL, COLLATERAL, INDIRECT, PUNITIVE, INCIDENTAL, CONSEQUENTIAL OR EXEMPLARY DAMAGES IN CONNECTION WITH OR ARISING OUT OF TI RESOURCES OR USE THEREOF, AND REGARDLESS OF WHETHER TI HAS BEEN ADVISED OF THE POSSIBILITY OF SUCH DAMAGES.

Unless TI has explicitly designated an individual product as meeting the requirements of a particular industry standard (e.g., ISO/TS 16949 and ISO 26262), TI is not responsible for any failure to meet such industry standard requirements.

Where TI specifically promotes products as facilitating functional safety or as compliant with industry functional safety standards, such products are intended to help enable customers to design and create their own applications that meet applicable functional safety standards and requirements. Using products in an application does not by itself establish any safety features in the application. Designers must ensure compliance with safety-related requirements and standards applicable to their applications. Designer may not use any TI products in life-critical medical equipment unless authorized officers of the parties have executed a special contract specifically governing such use. Life-critical medical equipment is medical equipment where failure of such equipment would cause serious bodily injury or death (e.g., life support, pacemakers, defibrillators, heart pumps, neurostimulators, and implantables). Such equipment includes, without limitation, all medical devices identified by the U.S. Food and Drug Administration as Class III devices and equivalent classifications outside the U.S.

TI may expressly designate certain products as completing a particular qualification (e.g., Q100, Military Grade, or Enhanced Product). Designers agree that it has the necessary expertise to select the product with the appropriate qualification designation for their applications and that proper product selection is at Designers' own risk. Designers are solely responsible for compliance with all legal and regulatory requirements in connection with such selection.

Designer will fully indemnify TI and its representatives against any damages, costs, losses, and/or liabilities arising out of Designer's non-compliance with the terms and provisions of this Notice.

Looking for pricing, stock, or lifecycle information?

Click below to explore more details on WIN SOURCE:

 [View TPS51601ADRBT on WIN SOURCE](#)

 [Texas Instruments](#) Information

Optimize Your Supply Chain with WIN SOURCE Solutions

-  Global Sourcing Solution
-  Obsolete Management
-  Cost Control Management
-  Shortage Management
-  Alternative Solution
-  Excess Inventory Management