



# THE DATASHEET OF TPS22968DPUT



## TPS22968 Dual Channel, Ultra-Low Resistance Load Switch

### 1 Features

- Integrated Dual Channel Load Switch
- Input Voltage Range: 0.8 V to 5.5 V
- VBIAS Voltage Range: 2.5 V to 5.5 V
  - Ideal for 1S Battery Configuration
- Ultra-Low  $R_{ON}$  Resistance
  - $R_{ON} = 27\text{ m}\Omega$  at  $V_{IN} = 5\text{ V}$  ( $V_{BIAS} = 5\text{ V}$ )
  - $R_{ON} = 25\text{ m}\Omega$  at  $V_{IN} = 3.3\text{ V}$  ( $V_{BIAS} = 5\text{ V}$ )
  - $R_{ON} = 25\text{ m}\Omega$  at  $V_{IN} = 1.8\text{ V}$  ( $V_{BIAS} = 5\text{ V}$ )
- 4-A Maximum Continuous Switch Current per Channel
- Low Quiescent Current
  - $55\text{ }\mu\text{A}$  at  $V_{BIAS} = 5\text{ V}$  (Both Channels)
  - $55\text{ }\mu\text{A}$  at  $V_{BIAS} = 5\text{ V}$  (Single Channel)
- Low Control Input Threshold Enables Use of 1.2-, 1.8-, 2.5-, 3.3-V Logic
- Configurable Rise Time<sup>(1)</sup>
- Quick Output Discharge (QOD)<sup>(2)</sup> (Optional)
- SON 14-Pin Package with Thermal Pad
- ESD Performance Tested per JEDEC Standard
  - 2-kV HBM and 1-kV CDM
- Latch-Up Performance Exceeds 100 mA per JESD 78, Class II
- GPIO Enable – Active High
- TPS22968N: Product Preview Only

(1) See the [Application Information](#) section for CT value vs. rise time

(2) This feature discharges the output of the switch to GND through a 270- $\Omega$  resistor, preventing the output from floating.

### 2 Applications

- Ultrabook™
- Notebooks and Netbooks
- Tablets
- Consumer Electronics
- Set-Top Boxes
- Telecom Systems

### 3 Description

The TPS22968x is a small, ultra-low  $R_{ON}$ , dual-channel load switch with controlled turn on. The device contains two N-channel MOSFETs that can operate over an input voltage range of 0.8 to 5.5 V and can support a maximum continuous current of 4 A per channel. Each switch is independently controlled by an on and off input (ON1 and ON2), which is capable of interfacing directly with low-voltage control signals. In TPS22968, a 270- $\Omega$  on-chip load resistor is added for output quick discharge when switch is turned off.

The TPS22968x is available in a small, space-saving package (DPU) with integrated thermal pad allowing for high power dissipation. The device is characterized for operation over the free-air temperature range of  $-40$  to  $+105^\circ\text{C}$ .

#### Device Information <sup>(1)</sup>

PART NUMBER	PACKAGE	BODY SIZE (NOM)
TPS22968	WSON (14)	3.00 mm x 2.00 mm
TPS22968N		

(1) For all available packages, see the orderable addendum at the end of the data sheet.

#### Typical Application Schematic

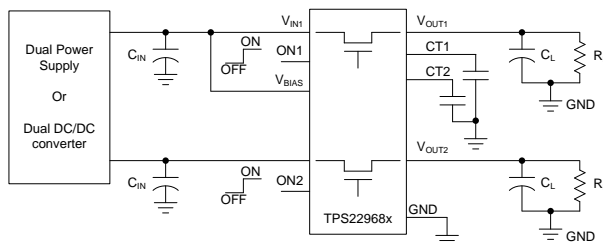

Copyright © 2016, Texas Instruments Incorporated



## Table of Contents

<b>1 Features</b> .....	<b>1</b>	9.3 Feature Description .....	<b>16</b>
<b>2 Applications</b> .....	<b>1</b>	9.4 Device Functional Modes .....	<b>17</b>
<b>3 Description</b> .....	<b>1</b>	<b>10 Application and Implementation</b> .....	<b>18</b>
<b>4 Revision History</b> .....	<b>2</b>	10.1 Application Information .....	<b>18</b>
<b>5 Device Comparison</b> .....	<b>4</b>	10.2 Typical Application .....	<b>21</b>
<b>6 Pin Configuration and Functions</b> .....	<b>4</b>	<b>11 Power Supply Recommendations</b> .....	<b>24</b>
<b>7 Specifications</b> .....	<b>5</b>	<b>12 Layout</b> .....	<b>24</b>
7.1 Absolute Maximum Ratings .....	<b>5</b>	12.1 Layout Guidelines .....	<b>24</b>
7.2 ESD Ratings .....	<b>5</b>	12.2 Layout Example .....	<b>24</b>
7.3 Recommended Operating Conditions .....	<b>5</b>	<b>13 Device and Documentation Support</b> .....	<b>25</b>
7.4 Thermal Information .....	<b>5</b>	13.1 Device Support .....	<b>25</b>
7.5 Electrical Characteristics (V <sub>BIAS</sub> = 5 V) .....	<b>6</b>	13.2 Documentation Support .....	<b>25</b>
7.6 Electrical Characteristics (V <sub>BIAS</sub> = 2.5 V) .....	<b>7</b>	13.3 Related Links .....	<b>25</b>
7.7 Switching Characteristics .....	<b>8</b>	13.4 Receiving Notification of Documentation Updates .....	<b>25</b>
7.8 Typical DC Characteristics .....	<b>8</b>	13.5 Community Resources .....	<b>25</b>
7.9 Typical AC Characteristics .....	<b>12</b>	13.6 Trademarks .....	<b>25</b>
<b>8 Parameter Measurement Information</b> .....	<b>14</b>	13.7 Electrostatic Discharge Caution .....	<b>26</b>
<b>9 Detailed Description</b> .....	<b>15</b>	13.8 Glossary .....	<b>26</b>
9.1 Overview .....	<b>15</b>	<b>14 Mechanical, Packaging, and Orderable Information</b> .....	<b>26</b>
9.2 Functional Block Diagram .....	<b>15</b>		

## 4 Revision History

<b>Changes from Revision D (March 2016) to Revision E</b>	<b>Page</b>
• Changed QOD description from <i>(TPS22968 only)</i> to <i>(Optional)</i> in <i>Features</i> section .....	<b>1</b>
<hr/>	
<b>Changes from Revision E (July 2016) to Revision F</b>	<b>Page</b>
• Changed <i>Functional Block Diagram</i> .....	<b>1</b>
<hr/>	
<b>Changes from Revision C (October 2015) to Revision D</b>	<b>Page</b>
• Made Changes to <i>Thermal Considerations</i> .....	<b>22</b>
<hr/>	
<b>Changes from Revision B (June 2015) to Revision C</b>	<b>Page</b>
• Updated information for TPS22968N release. ....	<b>1</b>
• Updated “TEST CONDITIONS” for RON. ....	<b>6</b>
• Updated “TEST CONDITIONS” for RON. ....	<b>7</b>
<hr/>	
<b>Changes from Revision A (July 2014) to Revision B</b>	<b>Page</b>
• Updated Typical Characteristics graphs. ....	<b>8</b>
<hr/>	
<b>Changes from Original (January 2014) to Revision A</b>	<b>Page</b>
• Added <i>Handling Rating</i> table, <i>Feature Description</i> section, <i>Device Functional Modes</i> , <i>Application and Implementation</i> section, <i>Power Supply Recommendations</i> section, <i>Layout</i> section, <i>Device and Documentation Support</i> section, and <i>Mechanical, Packaging, and Orderable Information</i> section .....	<b>1</b>

## 5 Device Comparison

DEVICE	Ron (typ) at VIN = 3.3 V, VBIAS = 5 V	QUICK OUTPUT DISCHARGE	MAXIMUM OUTPUT CURRENT	ENABLE
TPS22968	25 mΩ	Yes	4 A	Active High
TPS22968N	25 mΩ	No	4 A	Active High

## 6 Pin Configuration and Functions



### Pin Functions

PIN		I/O	DESCRIPTION
NO.	NAME		
1	VIN1	I	Switch 1 input. Bypass this input with a ceramic capacitor to GND
2			
3	ON1	I	Active-high switch 1 control input. Do not leave floating
4	VBIAS	I	Bias voltage. Power supply to the device. Recommended voltage range for this pin is 2.5 V to 5.5 V. See the <a href="#">VIN and VBIAS Voltage Range</a> section
5	ON2	I	Active-high switch 2 control input. Do not leave floating
6	VIN2	I	Switch 2 input. Bypass this input with a ceramic capacitor to GND
7			
8	VOUT2	O	Switch 2 output
9			
10	CT2	O	Switch 2 slew rate control. Can be left floating
11	GND	—	Ground
12	CT1	O	Switch 1 slew rate control. Can be left floating
13	VOUT1	O	Switch 2 output
14			
15	Thermal Pad	—	Thermal pad (exposed center pad) to alleviate thermal stress. Tie to GND. See the <a href="#">Application Information</a> section for layout guidelines

## 7 Specifications

### 7.1 Absolute Maximum Ratings

Over operating free-air temperature (unless otherwise noted)<sup>(1)</sup>

		MIN	MAX	UNIT <sup>(2)</sup>
V <sub>IN1,2</sub>	Input voltage	-0.3	6	V
V <sub>BIAS</sub>	Bias voltage	-0.3	6	V
V <sub>OUT1,2</sub>	Output voltage	-0.3	6	V
V <sub>ON1,2</sub>	ON voltage	-0.3	6	V
I <sub>MAX</sub>	Maximum continuous switch current per channel, T <sub>A</sub> = 30 °C		4	A
I <sub>PLS</sub>	Maximum pulsed switch current, pulse < 300 μs, 2% duty cycle		6	A
T <sub>J</sub>	Maximum junction temperature		125	°C
T <sub>stg</sub>	Storage temperature	-65	150	°C

- Stresses beyond those listed under *Absolute Maximum Ratings* may cause permanent damage to the device. These are stress ratings only, which do not imply functional operation of the device at these or any other conditions beyond those indicated under *Recommended Operating Conditions*. Exposure to absolute-maximum-rated conditions for extended periods may affect device reliability.
- All voltage values are with respect to network ground terminal.

### 7.2 ESD Ratings

		VALUE	UNIT
V <sub>(ESD)</sub>	Electrostatic discharge	Human-body model (HBM), per ANSI/ESDA/JEDEC JS-001 <sup>(1)</sup>	±2000
		Charged-device model (CDM), per JEDEC specification JESD22-C101 <sup>(2)</sup>	±1000

- JEDEC document JEP155 states that 500-V HBM allows safe manufacturing with a standard ESD control process. Manufacturing with less than 500-V HBM is possible with the necessary precautions.
- JEDEC document JEP157 states that 250-V CDM allows safe manufacturing with a standard ESD control process. Manufacturing with less than 250-V CDM is possible with the necessary precautions.

### 7.3 Recommended Operating Conditions

		MIN	MAX	UNIT
V <sub>IN1,2</sub>	Input voltage	0.8	V <sub>BIAS</sub>	V
V <sub>BIAS</sub>	Bias voltage	2.5	5.5	V
V <sub>ON1,2</sub>	ON voltage	0	5.5	V
V <sub>OUT1,2</sub>	Output voltage		V <sub>IN</sub>	V
V <sub>IH, ON1,2</sub>	High-level input voltage, ON1,2	V <sub>BIAS</sub> = 2.5 V to 5.5 V		V
V <sub>IL, ON1,2</sub>	Low-level input voltage, ON1,2	V <sub>BIAS</sub> = 2.5 V to 5.5 V		V
C <sub>IN1,2</sub>	Input capacitor	1 <sup>(1)</sup>		μF
T <sub>A</sub>	Operating free-air temperature <sup>(2)</sup>	-40	105	°C

- See the [Application Information](#) section.
- In applications where high power dissipation and/or poor package thermal resistance is present, the maximum ambient temperature may have to be derated. Maximum ambient temperature [T<sub>A(max)</sub>] is dependent on the maximum operating junction temperature [T<sub>J(max)</sub>], the maximum power dissipation of the device in the application [P<sub>D(max)</sub>], and the junction-to-ambient thermal resistance of the part/package in the application (R<sub>θJA</sub>), as given by the following equation: T<sub>A(max)</sub> = T<sub>J(max)</sub> - (R<sub>θJA</sub> × P<sub>D(max)</sub>).

### 7.4 Thermal Information

	THERMAL METRIC <sup>(1)</sup> (2)	TPS22968	UNIT
		DPU (WSON)	
		14 PINS	
R <sub>θJA</sub>	Junction-to-ambient thermal resistance	62.5	°C/W
R <sub>θJC(top)</sub>	Junction-to-case (top) thermal resistance	70.2	°C/W
R <sub>θJB</sub>	Junction-to-board thermal resistance	23.2	°C/W
ψ <sub>JT</sub>	Junction-to-top characterization parameter	2.5	°C/W

- For more information about traditional and new thermal metrics, see the [Semiconductor and IC Package Thermal Metrics](#) application report.
- For thermal estimates of this device based on PCB copper area, see the [TI PCB Thermal Calculator](#).

**Thermal Information (continued)**

THERMAL METRIC <sup>(1)</sup> <sup>(2)</sup>		TPS22968	UNIT
		DPU (WSON)	
		14 PINS	
$\psi_{JB}$	Junction-to-board characterization parameter	23.2	°C/W
$R_{\theta JC(bot)}$	Junction-to-case (bottom) thermal resistance	9	°C/W

**7.5 Electrical Characteristics ( $V_{BIAS} = 5\text{ V}$ )**

Unless otherwise noted, the specification in the following table applies over the operating ambient temperature  $-40^{\circ}\text{C} \leq T_A \leq +105^{\circ}\text{C}$  (full) and  $V_{BIAS} = 5\text{ V}$ . Typical values are for  $T_A = 25^{\circ}\text{C}$  (unless otherwise noted).

PARAMETER		TEST CONDITIONS	$T_A$	MIN	TYP	MAX	UNIT			
<b>POWER SUPPLIES AND CURRENTS</b>										
$I_{Q, VBIAS}$	$V_{BIAS}$ quiescent current (both channels)	$I_{OUT1} = I_{OUT2} = 0, V_{IN1,2} = V_{ON1,2} = V_{BIAS} = 5\text{ V}$	$-40^{\circ}\text{C}$ to $+105^{\circ}\text{C}$	55	70		$\mu\text{A}$			
	$V_{BIAS}$ quiescent current (single channel)	$I_{OUT1} = I_{OUT2} = 0, V_{ON2} = 0\text{ V}, V_{IN1,2} = V_{ON1} = V_{BIAS} = 5\text{ V}$	$-40^{\circ}\text{C}$ to $+105^{\circ}\text{C}$	55	68		$\mu\text{A}$			
$I_{SD, VBIAS}$	$V_{BIAS}$ shutdown current	$V_{ON1,2} = 0\text{ V}, V_{OUT1,2} = 0\text{ V}$	$-40^{\circ}\text{C}$ to $+105^{\circ}\text{C}$	1	2		$\mu\text{A}$			
$I_{SD, VIN1,2}$	$V_{IN1,2}$ shutdown current (per channel)	$V_{ON1,2} = 0\text{ V}, V_{OUT1,2} = 0\text{ V}$	$V_{IN1,2} = 5\text{ V}$	$-40^{\circ}\text{C}$ to $+85^{\circ}\text{C}$	0.5	8	$\mu\text{A}$			
				$-40^{\circ}\text{C}$ to $+105^{\circ}\text{C}$		10				
			$V_{IN1,2} = 3.3\text{ V}$	$-40^{\circ}\text{C}$ to $+85^{\circ}\text{C}$	0.1	3				
				$-40^{\circ}\text{C}$ to $+105^{\circ}\text{C}$		4				
			$V_{IN1,2} = 1.8\text{ V}$	$-40^{\circ}\text{C}$ to $+85^{\circ}\text{C}$	0.07	2				
				$-40^{\circ}\text{C}$ to $+105^{\circ}\text{C}$		3				
			$V_{IN1,2} = 1.2\text{ V}$	$-40^{\circ}\text{C}$ to $+85^{\circ}\text{C}$	0.05	1				
				$-40^{\circ}\text{C}$ to $+105^{\circ}\text{C}$		2				
		$V_{IN1,2} = 0.8\text{ V}$	$-40^{\circ}\text{C}$ to $+85^{\circ}\text{C}$	0.04	1					
			$-40^{\circ}\text{C}$ to $+105^{\circ}\text{C}$		2					
$I_{ON1,2}$	ON pin input leakage current	$V_{ON} = 5.5\text{ V}$	$-40^{\circ}\text{C}$ to $+105^{\circ}\text{C}$		0.1		$\mu\text{A}$			
<b>RESISTANCE CHARACTERISTICS</b>										
$R_{ON}$	On-state resistance	$I_{OUT} = -200\text{ mA}, V_{BIAS} = 5\text{ V}, V_{ON1,2} = 5\text{ V}$	$V_{IN} = 5\text{ V}$	25°C	27	36	$\text{m}\Omega$			
				$-40^{\circ}\text{C}$ to $+85^{\circ}\text{C}$		40				
				$-40^{\circ}\text{C}$ to $+105^{\circ}\text{C}$		42				
			$V_{IN} = 3.3\text{ V}$	25°C	25	34	$\text{m}\Omega$			
				$-40^{\circ}\text{C}$ to $+85^{\circ}\text{C}$		38				
				$-40^{\circ}\text{C}$ to $+105^{\circ}\text{C}$		40				
			$V_{IN} = 1.8\text{ V}$	25°C	25	34	$\text{m}\Omega$			
				$-40^{\circ}\text{C}$ to $+85^{\circ}\text{C}$		38				
				$-40^{\circ}\text{C}$ to $+105^{\circ}\text{C}$		40				
			$V_{IN} = 1.5\text{ V}$	25°C	25	34	$\text{m}\Omega$			
				$-40^{\circ}\text{C}$ to $+85^{\circ}\text{C}$		38				
				$-40^{\circ}\text{C}$ to $+105^{\circ}\text{C}$		40				
			$V_{IN} = 1.2\text{ V}$	25°C	25	34	$\text{m}\Omega$			
				$-40^{\circ}\text{C}$ to $+85^{\circ}\text{C}$		38				
				$-40^{\circ}\text{C}$ to $+105^{\circ}\text{C}$		40				
			$V_{IN} = 0.8\text{ V}$	25°C	25	34	$\text{m}\Omega$			
				$-40^{\circ}\text{C}$ to $+85^{\circ}\text{C}$		38				
				$-40^{\circ}\text{C}$ to $+105^{\circ}\text{C}$		40				
			$R_{PD}^{(1)}$	Output pulldown resistance	$V_{IN} = 5\text{ V}, V_{ON} = 0\text{ V}, I_{OUT} = 10\text{ mA}$	$-40^{\circ}\text{C}$ to $+105^{\circ}\text{C}$	270	320		$\Omega$

(1) TPS22968 only.

## 7.6 Electrical Characteristics ( $V_{BIAS} = 2.5\text{ V}$ )

Unless otherwise noted, the specification in the following table applies over the operating ambient temperature  $-40\text{ °C} \leq T_A \leq +105\text{ °C}$  (full) and  $V_{BIAS} = 2.5\text{ V}$ . Typical values are for  $T_A = 25\text{ °C}$  (unless otherwise noted).

PARAMETER		TEST CONDITIONS	$T_A$	MIN	TYP	MAX	UNIT
<b>POWER SUPPLIES AND CURRENTS</b>							
$I_Q, V_{BIAS}$	$V_{BIAS}$ quiescent current (both channels)	$I_{OUT1} = I_{OUT2} = 0, V_{IN1,2} = V_{ON1,2} = V_{BIAS} = 2.5\text{ V}$	$-40\text{ °C}$ to $+105\text{ °C}$	18	27		$\mu\text{A}$
	$V_{BIAS}$ quiescent current (single channel)	$I_{OUT1} = I_{OUT2} = 0, V_{ON2} = 0\text{ V}, V_{IN1,2} = V_{ON1} = V_{BIAS} = 2.5\text{ V}$	$-40\text{ °C}$ to $+105\text{ °C}$	18	27		$\mu\text{A}$
$I_{SD}, V_{BIAS}$	$V_{BIAS}$ shutdown current	$V_{ON1,2} = 0\text{ V}, V_{OUT1,2} = 0\text{ V}$	$-40\text{ °C}$ to $+105\text{ °C}$	0.5	2		$\mu\text{A}$
$I_{SD}, V_{IN1,2}$	$V_{IN1,2}$ shutdown current (per channel)	$V_{ON1,2} = 0\text{ V}, V_{OUT1,2} = 0\text{ V}$	$V_{IN1,2} = 2.5\text{ V}$	$-40\text{ °C}$ to $+85\text{ °C}$	0.1	2	$\mu\text{A}$
				$-40\text{ °C}$ to $+105\text{ °C}$		4	
			$V_{IN1,2} = 1.8\text{ V}$	$-40\text{ °C}$ to $+85\text{ °C}$	0.07	2	
				$-40\text{ °C}$ to $+105\text{ °C}$		3	
			$V_{IN1,2} = 1.2\text{ V}$	$-40\text{ °C}$ to $+85\text{ °C}$	0.05	1	
	$-40\text{ °C}$ to $+105\text{ °C}$		2				
	$V_{IN1,2} = 0.8\text{ V}$	$-40\text{ °C}$ to $+85\text{ °C}$	0.04	1			
		$-40\text{ °C}$ to $+105\text{ °C}$		2			
$I_{ON1,2}$	ON pin input leakage current	$V_{ON} = 5.5\text{ V}$	$-40\text{ °C}$ to $+85\text{ °C}$		0.1		$\mu\text{A}$
<b>RESISTANCE CHARACTERISTICS</b>							
$R_{ON}$	On-state resistance	$I_{OUT} = -200\text{ mA}, V_{BIAS} = 2.5\text{ V}, V_{ON1,2} = 5\text{ V}$	$V_{IN} = 2.5\text{ V}$	25 $^{\circ}\text{C}$	30	39	$\text{m}\Omega$
				$-40\text{ °C}$ to $+85\text{ °C}$		44	
				$-40\text{ °C}$ to $+105\text{ °C}$		46	
			$V_{IN} = 1.8\text{ V}$	25 $^{\circ}\text{C}$	28	36	$\text{m}\Omega$
				$-40\text{ °C}$ to $+85\text{ °C}$		41	
				$-40\text{ °C}$ to $+105\text{ °C}$		43	
			$V_{IN} = 1.5\text{ V}$	25 $^{\circ}\text{C}$	28	36	$\text{m}\Omega$
				$-40\text{ °C}$ to $+85\text{ °C}$		41	
				$-40\text{ °C}$ to $+105\text{ °C}$		43	
			$V_{IN} = 1.2\text{ V}$	25 $^{\circ}\text{C}$	27	36	$\text{m}\Omega$
				$-40\text{ °C}$ to $+85\text{ °C}$		41	
				$-40\text{ °C}$ to $+105\text{ °C}$		43	
$V_{IN} = 0.8\text{ V}$	25 $^{\circ}\text{C}$	26	35	$\text{m}\Omega$			
	$-40\text{ °C}$ to $+85\text{ °C}$		39				
	$-40\text{ °C}$ to $+105\text{ °C}$		41				
$R_{PD}^{(1)}$	Output pulldown resistance	$V_{IN} = 2.5\text{ V}, V_{ON} = 0\text{ V}, I_{OUT} = 10\text{ mA}$	$-40\text{ °C}$ to $+105\text{ °C}$	270	320		$\Omega$

(1) TPS22968 only.

### 7.7 Switching Characteristics

PARAMETER	TEST CONDITION	MIN	TYP	MAX	UNIT
<b><math>V_{IN} = V_{ON} = V_{BIAS} = 5\text{ V}</math>, <math>T_A = 25\text{ }^\circ\text{C}</math> (unless otherwise noted)</b>					
$t_{ON}$ Turnon time	$R_L = 10\ \Omega$ , $C_L = 0.1\ \mu\text{F}$ , $C_T = 1000\ \text{pF}$		1128		$\mu\text{s}$
$t_{OFF}$ Turnoff time	$R_L = 10\ \Omega$ , $C_L = 0.1\ \mu\text{F}$ , $C_T = 1000\ \text{pF}$		5		
$t_R$ $V_{OUT}$ rise time	$R_L = 10\ \Omega$ , $C_L = 0.1\ \mu\text{F}$ , $C_T = 1000\ \text{pF}$		1387		
$t_F$ $V_{OUT}$ fall time	$R_L = 10\ \Omega$ , $C_L = 0.1\ \mu\text{F}$ , $C_T = 1000\ \text{pF}$		2		
$t_D$ ON delay time	$R_L = 10\ \Omega$ , $C_L = 0.1\ \mu\text{F}$ , $C_T = 1000\ \text{pF}$		455		
<b><math>V_{IN} = 0.8\text{ V}</math>, <math>V_{ON} = V_{BIAS} = 5\text{ V}</math>, <math>T_A = 25\text{ }^\circ\text{C}</math> (unless otherwise noted)</b>					
$t_{ON}$ Turnon time	$R_L = 10\ \Omega$ , $C_L = 0.1\ \mu\text{F}$ , $C_T = 1000\ \text{pF}$		508		$\mu\text{s}$
$t_{OFF}$ Turnoff time	$R_L = 10\ \Omega$ , $C_L = 0.1\ \mu\text{F}$ , $C_T = 1000\ \text{pF}$		33		
$t_R$ $V_{OUT}$ rise time	$R_L = 10\ \Omega$ , $C_L = 0.1\ \mu\text{F}$ , $C_T = 1000\ \text{pF}$		273		
$t_F$ $V_{OUT}$ fall time	$R_L = 10\ \Omega$ , $C_L = 0.1\ \mu\text{F}$ , $C_T = 1000\ \text{pF}$		2		
$t_D$ ON delay time	$R_L = 10\ \Omega$ , $C_L = 0.1\ \mu\text{F}$ , $C_T = 1000\ \text{pF}$		377		
<b><math>V_{IN} = 2.5\text{ V}</math>, <math>V_{ON} = 5\text{ V}</math>, <math>V_{BIAS} = 2.5\text{ V}</math>, <math>T_A = 25\text{ }^\circ\text{C}</math> (unless otherwise noted)</b>					
$t_{ON}$ Turnon time	$R_L = 10\ \Omega$ , $C_L = 0.1\ \mu\text{F}$ , $C_T = 1000\ \text{pF}$		1718		$\mu\text{s}$
$t_{OFF}$ Turnoff time	$R_L = 10\ \Omega$ , $C_L = 0.1\ \mu\text{F}$ , $C_T = 1000\ \text{pF}$		7		
$t_R$ $V_{OUT}$ rise time	$R_L = 10\ \Omega$ , $C_L = 0.1\ \mu\text{F}$ , $C_T = 1000\ \text{pF}$		1701		
$t_F$ $V_{OUT}$ fall time	$R_L = 10\ \Omega$ , $C_L = 0.1\ \mu\text{F}$ , $C_T = 1000\ \text{pF}$		2		
$t_D$ ON delay time	$R_L = 10\ \Omega$ , $C_L = 0.1\ \mu\text{F}$ , $C_T = 1000\ \text{pF}$		859		
<b><math>V_{IN} = 0.8\text{ V}</math>, <math>V_{ON} = 5\text{ V}</math>, <math>V_{BIAS} = 2.5\text{ V}</math>, <math>T_A = 25\text{ }^\circ\text{C}</math> (unless otherwise noted)</b>					
$t_{ON}$ Turnon time	$R_L = 10\ \Omega$ , $C_L = 0.1\ \mu\text{F}$ , $C_T = 1000\ \text{pF}$		1117		$\mu\text{s}$
$t_{OFF}$ Turnoff time	$R_L = 10\ \Omega$ , $C_L = 0.1\ \mu\text{F}$ , $C_T = 1000\ \text{pF}$		30		
$t_R$ $V_{OUT}$ rise time	$R_L = 10\ \Omega$ , $C_L = 0.1\ \mu\text{F}$ , $C_T = 1000\ \text{pF}$		651		
$t_F$ $V_{OUT}$ fall time	$R_L = 10\ \Omega$ , $C_L = 0.1\ \mu\text{F}$ , $C_T = 1000\ \text{pF}$		2		
$t_D$ ON delay time	$R_L = 10\ \Omega$ , $C_L = 0.1\ \mu\text{F}$ , $C_T = 1000\ \text{pF}$		775		

### 7.8 Typical DC Characteristics

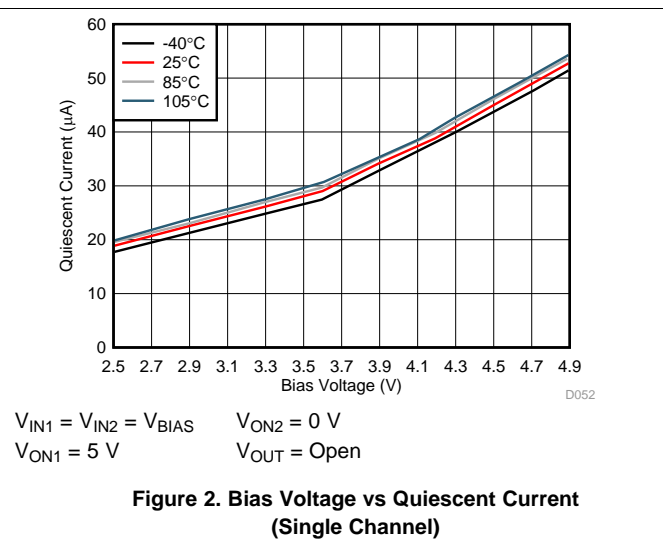
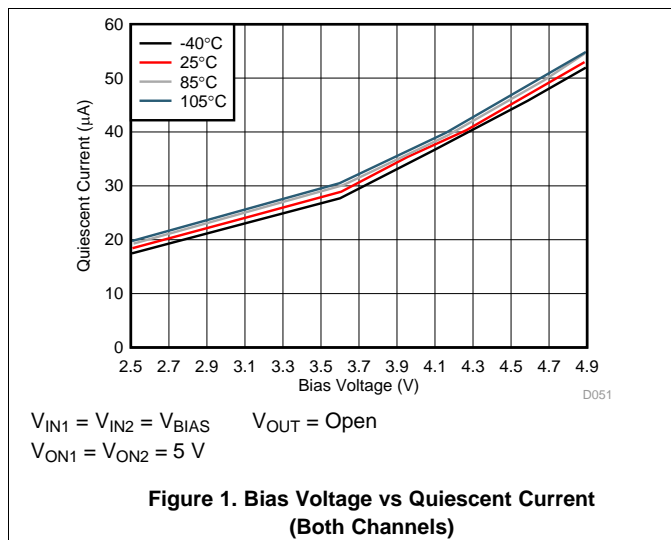

Typical DC Characteristics (continued)

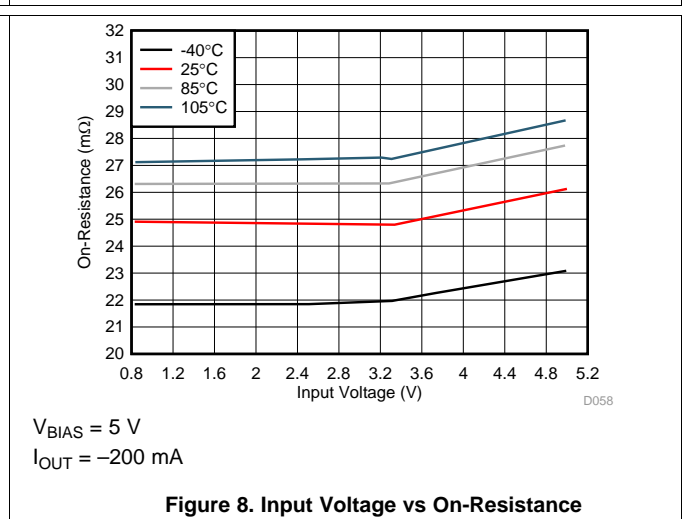
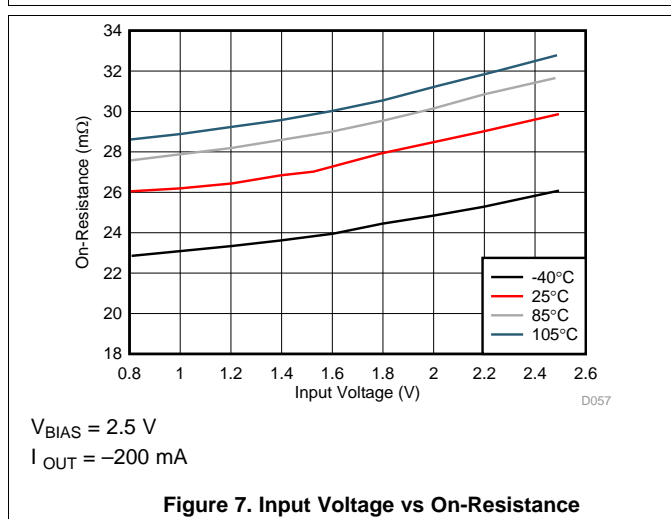
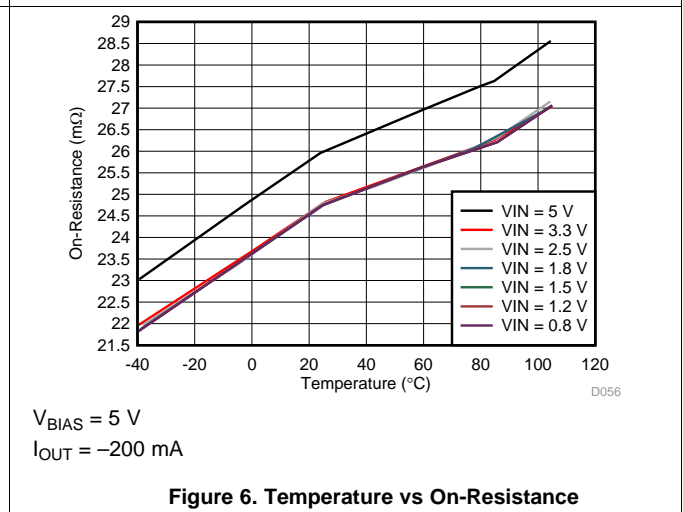
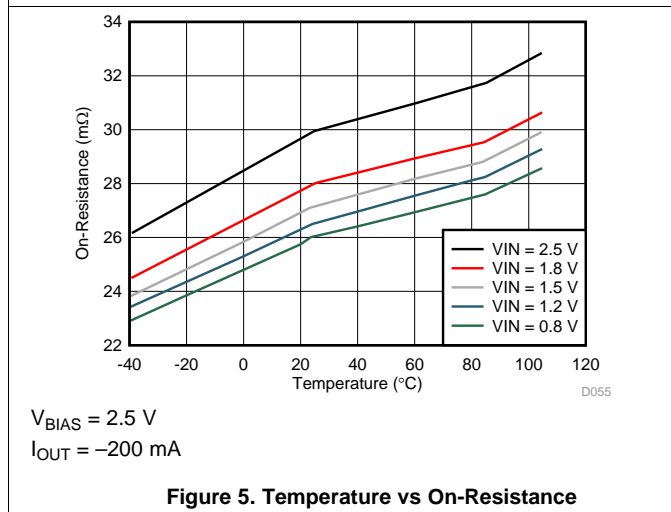
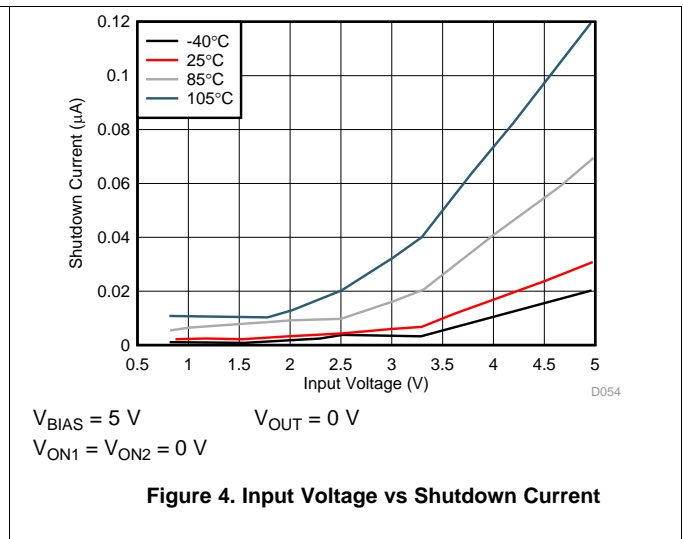
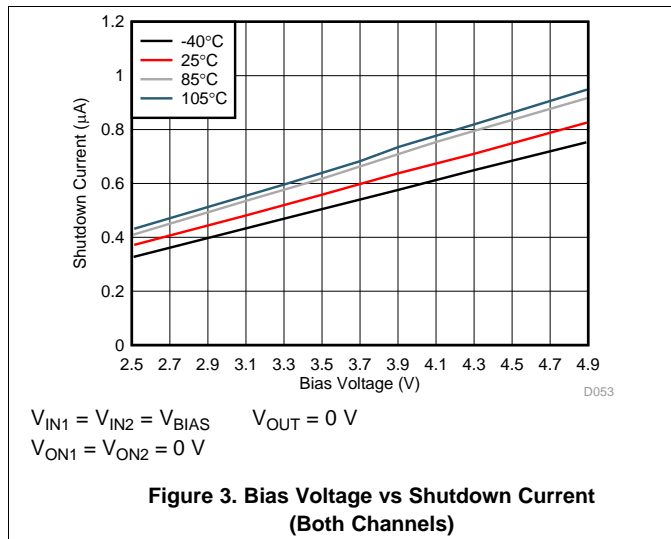

Typical DC Characteristics (continued)

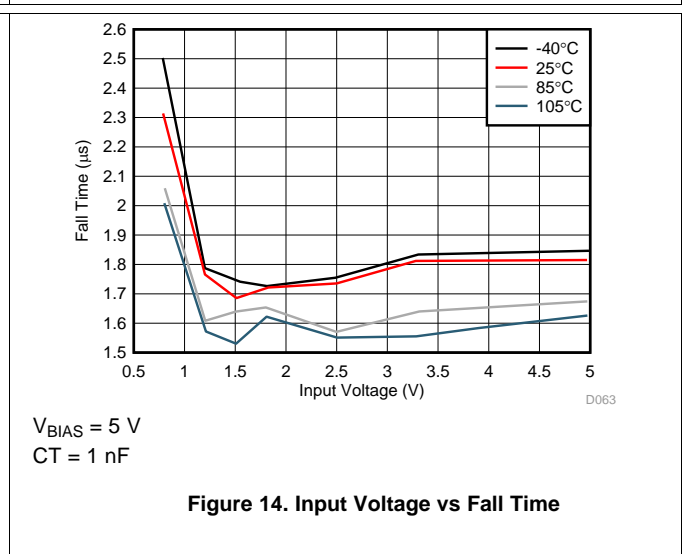
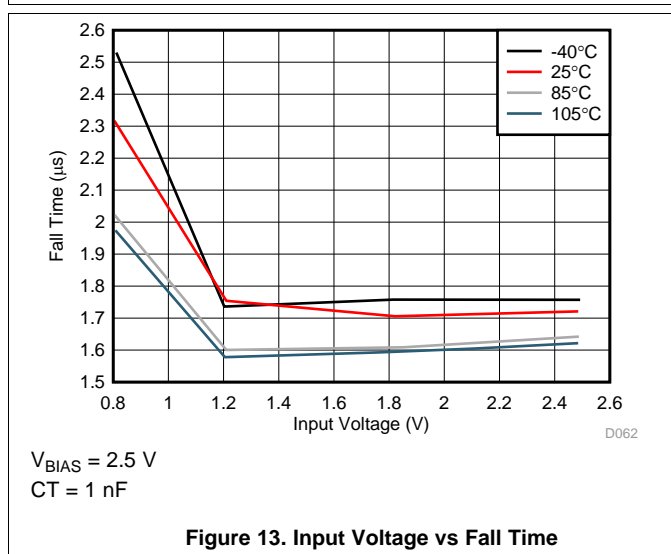
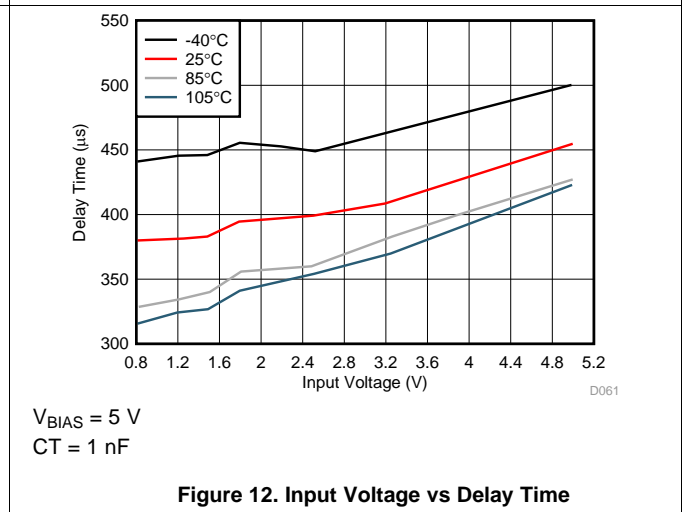
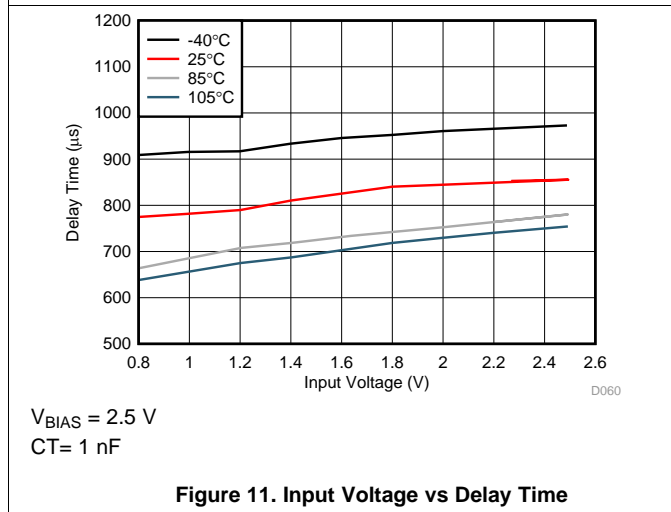
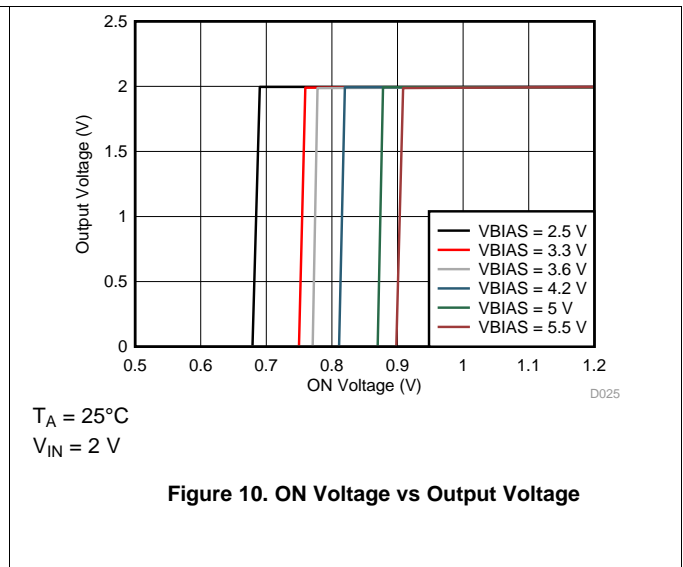
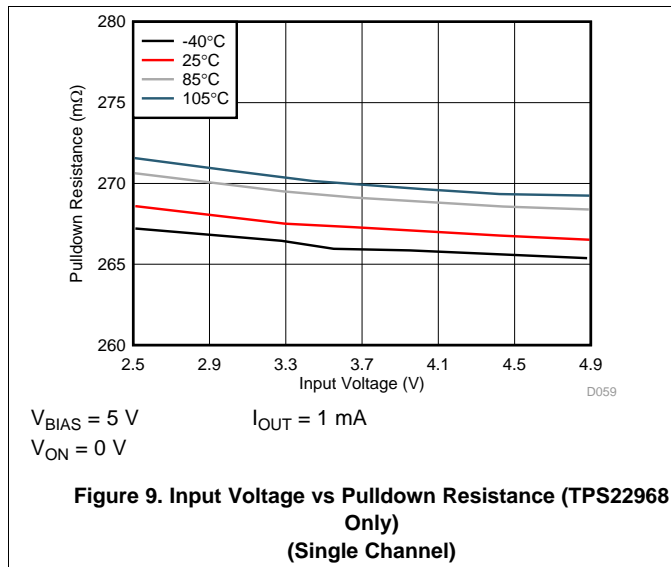

Typical DC Characteristics (continued)

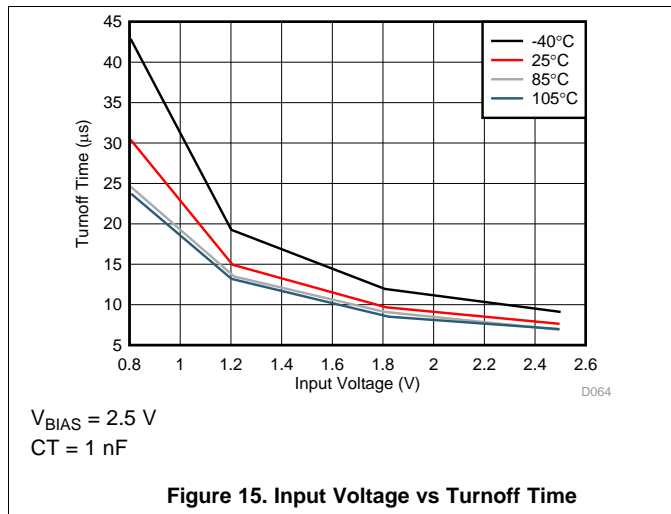

Figure 15. Input Voltage vs Turnoff Time

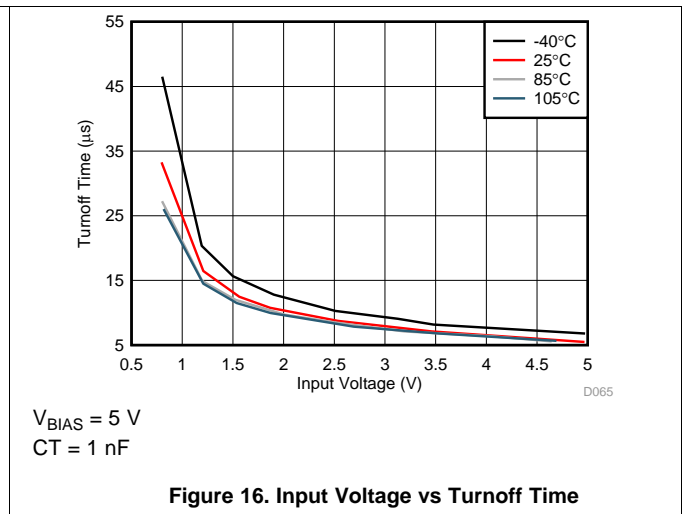

Figure 16. Input Voltage vs Turnoff Time

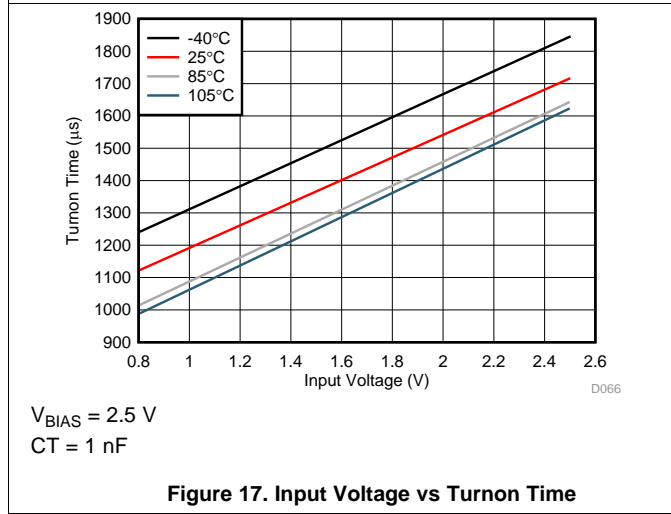

Figure 17. Input Voltage vs Turnon Time

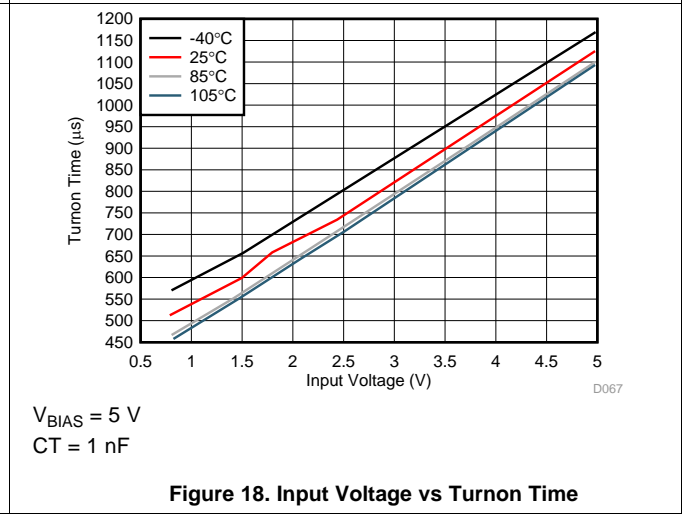

Figure 18. Input Voltage vs Turnon Time

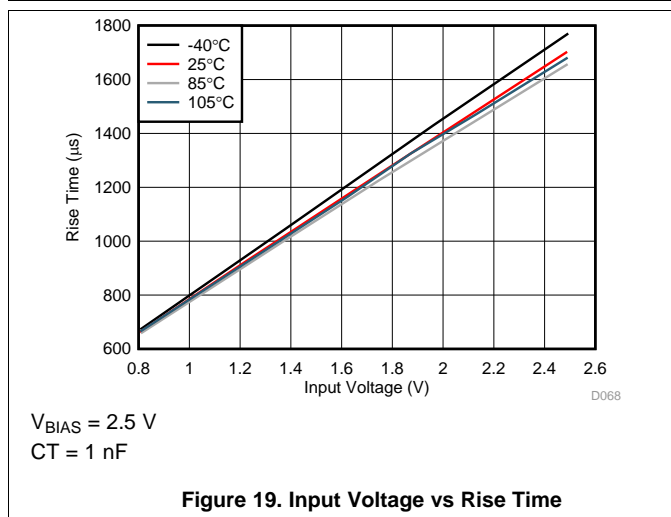

Figure 19. Input Voltage vs Rise Time

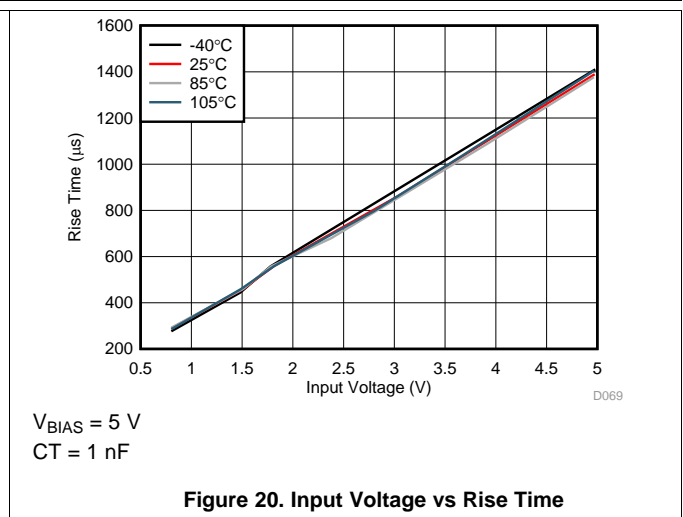

Figure 20. Input Voltage vs Rise Time

### 7.9 Typical AC Characteristics

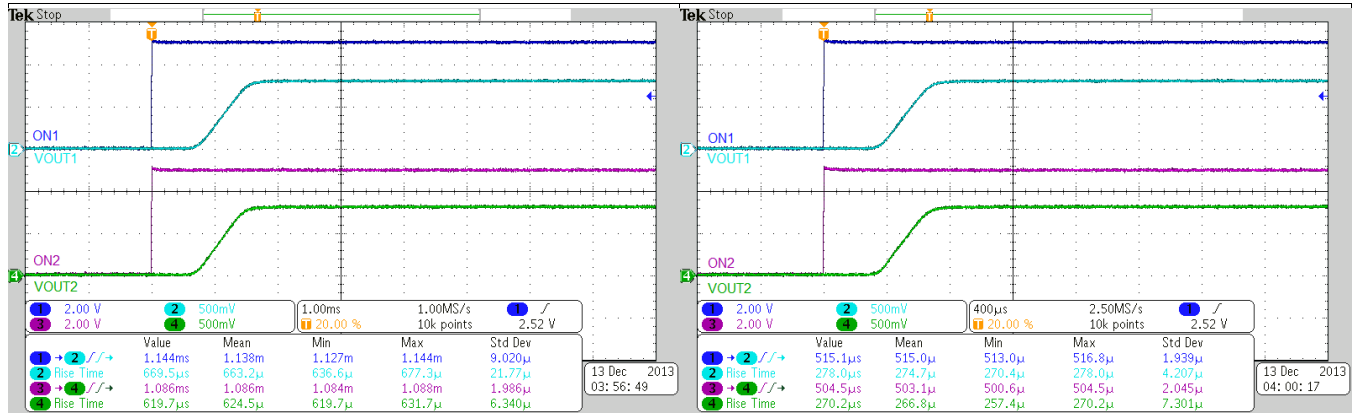

Figure 21. Turnon Response Time

Figure 22. Turnon Response Time

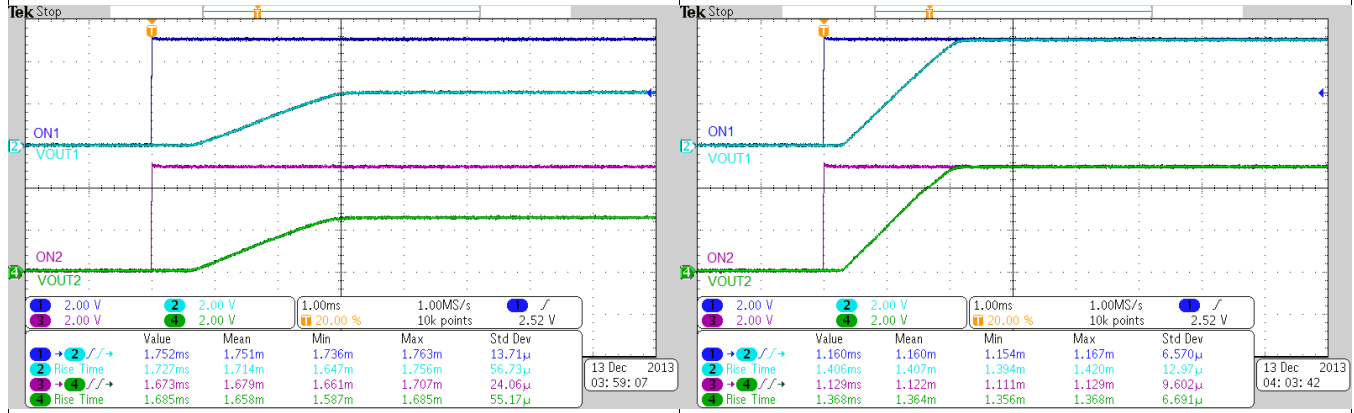

Figure 23. Turnon Response Time

Figure 24. Turnon Response Time

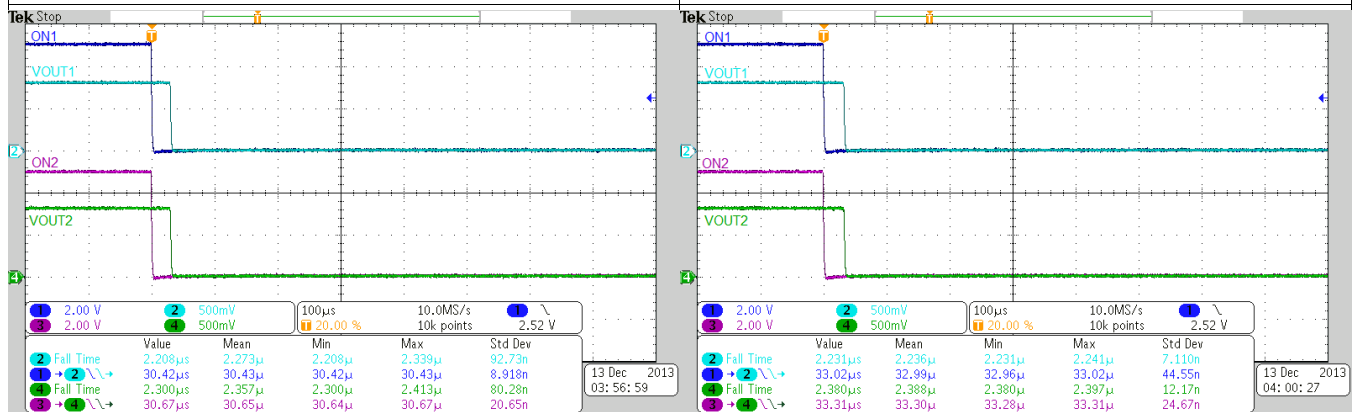
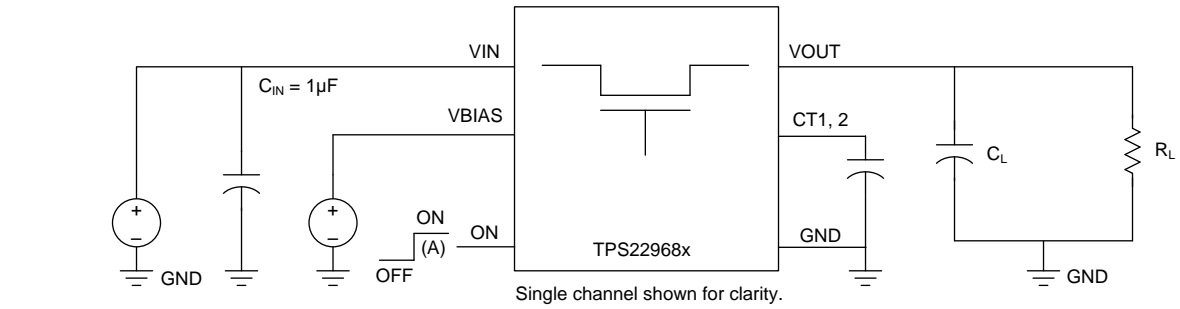

Figure 25. TurnOff Response Time

Figure 26. Turnoff Response Time



## 8 Parameter Measurement Information



Copyright © 2016, Texas Instruments Incorporated

TEST CIRCUIT

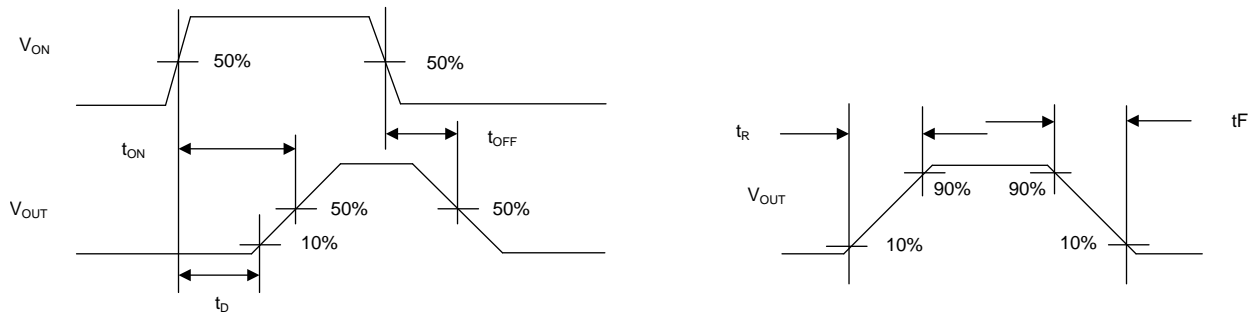

TIMING DIAGRAMS

- A. Rise and fall times of the control signal is 100 ns.

**Figure 29. Test Circuit and Timing Waveforms**

## 9 Detailed Description

### 9.1 Overview

The TPS22968 is a 5.5-V, 4-A, dual-channel ultra-low  $R_{ON}$  load switch with controlled turnon. The device contains two N-channel MOSFETs. Each channel can support a maximum continuous current of 4 A and is controlled by an on and off GPIO-compatible input. The ON pin must be connected and cannot be left floating. The device is designed to control the turnon rate and therefore the inrush current. By controlling the inrush current, power supply sag can be reduced during turnon. The slew rate for each channel is set by connecting a capacitor to GND on the CT pins.

The slew rate is proportional to the capacitor on the CT pin. See the [Adjustable Rise Time](#) section to determine the correct CT value for a desired rise time.

The internal circuitry is powered by the VBIAS pin, which supports voltages from 2.5 V to 5.5 V. This circuitry includes the charge pump, QOD (optional), and control logic. For these internal blocks to function correctly, a voltage between 2.5 V and 5.5 V must be supplied to VBIAS.

When a voltage is supplied to VBIAS, the ON1 pin goes low, and the ON2 pins go low, the QOD turns on. This connects VOUT1 and VOUT2 to GND through an on-chip resistor. The typical pulldown resistance ( $R_{PD}$ ) is 270  $\Omega$ .

### 9.2 Functional Block Diagram

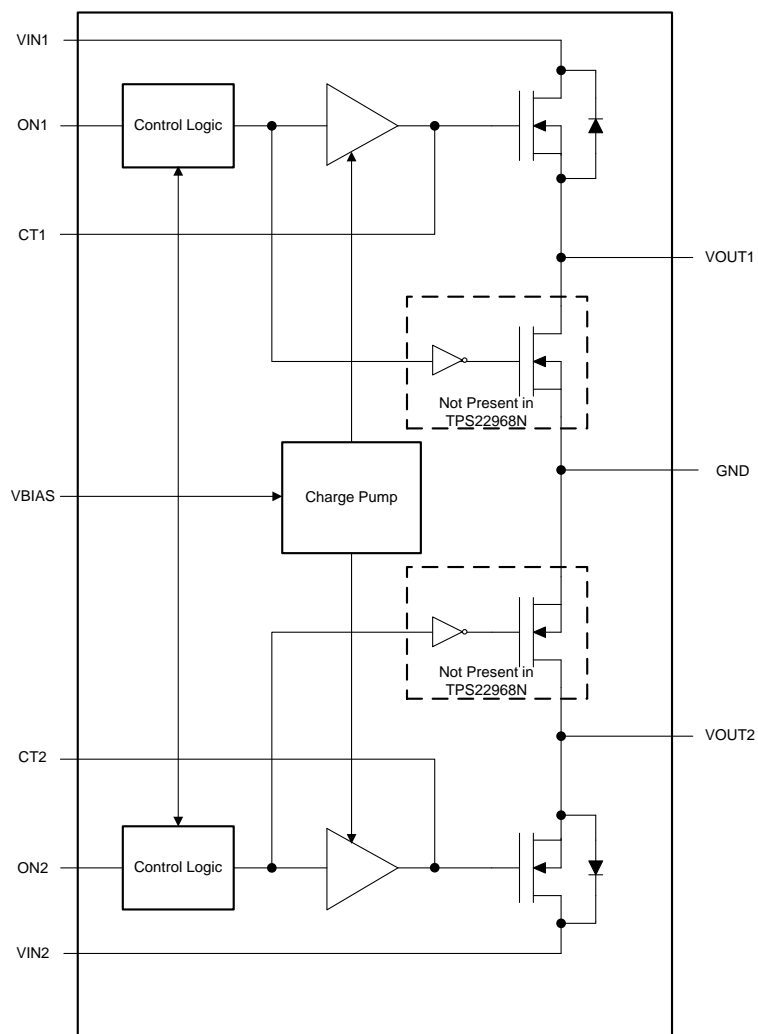

Copyright © 2017, Texas Instruments Incorporated

## 9.3 Feature Description

### 9.3.1 ON and OFF Control

The ON pins control the state of the switch. Asserting ON high enables the switch. ON is active high and has a low threshold, making it capable of interfacing with low-voltage signals. The ON pin is compatible with standard GPIO logic threshold. It can be used with any microcontroller with 1.2 V or higher GPIO voltage. This pin cannot be left floating and must be tied either high or low for proper functionality.

### 9.3.2 Input Capacitor (Optional)

When the switch turns on into a discharged load capacitor or short-circuit, a capacitor must be placed between VIN and GND to limit the voltage drop on the input supply caused by transient inrush currents. A 1- $\mu$ F ceramic capacitor ( $C_{IN}$ ), placed close to the pins, is sufficient. Higher values of  $C_{IN}$  can be used to further reduce the voltage drop during high-current application. When switching heavy loads, TI recommends having an input capacitor 10x higher than the output capacitor to avoid excessive voltage drop.

### 9.3.3 Output Capacitor (Optional)

TI highly recommends a  $C_{IN}$  greater than  $C_L$ , because of the integrated body diode in the NMOS switch. A  $C_L$  greater than  $C_{IN}$  can cause the voltage on VOUT to exceed VIN when the system supply is removed. This could result in current flow through the body diode from VOUT to VIN. TI recommends a  $C_{IN}$  to  $C_L$  ratio of 10 to 1 for minimizing  $V_{IN}$  dip caused by inrush currents during startup.

### 9.3.4 QOD (Optional)

The TPS22968 includes a QOD feature. When the switch is disabled, a discharge resistor is connected between VOUT and GND. This resistor has a typical value of 270  $\Omega$  and prevents the output from floating while the switch is disabled.

### 9.3.5 VIN and VBIAS Voltage Range

For optimal  $R_{ON}$  performance, make sure  $V_{IN} \leq V_{BIAS}$ . The device is still functional if  $V_{IN} > V_{BIAS}$ , but it exhibits  $R_{ON}$  greater than what is listed in the [Electrical Characteristics \( \$V\_{BIAS} = 5 V\$ \)](#) and [Electrical Characteristics \( \$V\_{BIAS} = 2.5 V\$ \)](#) table. See [Figure 30](#) for an example of a typical device. Notice the increasing  $R_{ON}$  as  $V_{IN}$  exceeds  $V_{BIAS}$  voltage. Be sure to never exceed the maximum voltage rating for  $V_{IN}$  and  $V_{BIAS}$ .

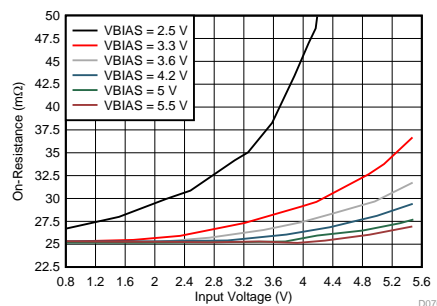

Temperature = 25°C

$I_{OUT} = 200 \text{ mA}$

Figure 30. On-Resistance vs Input Voltage

## Feature Description (continued)

### 9.3.6 Adjustable Rise Time

A capacitor to GND on the CT pins sets the slew rate for each channel. The capacitor to GND on the CT pins must be rated for 25 V and above. An approximate formula for the relationship between CT and slew rate with  $V_{BIAS} = 5\text{ V}$  is shown in [Equation 1](#).

$$SR = 0.32 \times CT + 13.7$$

where

- SR is the slew rate (in  $\mu\text{s/V}$ )
- CT is the capacitance value on the CT pin (in pF)
- The units for the constant 13.7 is in  $\mu\text{s/V}$ .

(1)

Rise time can be calculated by multiplying the input voltage by the slew rate. [Table 1](#) contains rise time values measured on a typical device.

**Table 1. Rise Time Table**

CTx (pF)	Typical values at 25°C with a 25-V X7R 10% ceramic capacitor on CT <sup>(1)</sup>						
	VIN = 5 V	VIN = 3.3 V	VIN = 2.5 V	VIN = 1.8 V	VIN = 1.5 V	VIN = 1.2V	VIN = 0.8 V
0	65	48	41	35	31	29	24
220	378	253	197	152	131	111	83
470	704	474	363	272	234	192	140
1000	1387	931	717	544	449	372	273
2200	3062	2021	1536	1173	991	825	595
4700	7091	4643	3547	2643	2213	1828	1349
10000	14781	9856	7330	5507	4600	3841	2805

(1) RISE TIME ( $\mu\text{s}$ ) 10% - 90%,  $C_L = 0.1\ \mu\text{F}$ ,  $C_{IN} = 1\ \mu\text{F}$ ,  $R_L = 10\ \Omega$ ,  $V_{BIAS} = 5\text{ V}$

## 9.4 Device Functional Modes

[Table 2](#) lists the device function table.

**Table 2. Functional Table**

ONx	VINx to VOUTx	VOUTx to GND
L	Off	On
H	On	Off

## 10 Application and Implementation

### NOTE

Information in the following applications sections is not part of the TI component specification, and TI does not warrant its accuracy or completeness. TI's customers are responsible for determining suitability of components for their purposes. Customers should validate and test their design implementation to confirm system functionality.

### 10.1 Application Information

This section highlights some of the design considerations for implementing this device in various applications. A PSPICE model for this device is also available on the [product page](#) for additional information.

#### 10.1.1 Parallel Configuration

To increase the current capabilities and lower the  $R_{ON}$  by approximately 50%, both channels can be placed in parallel as shown in [Figure 31](#) (parallel configuration). With this configuration, the CT1 and CT2 pins can be tied together to use one capacitor, CT, as shown in [Figure 31](#). With a single CT capacitor, the rise time is half of the typical rise-time value. Refer to the [Table 1](#) for typical timing values.

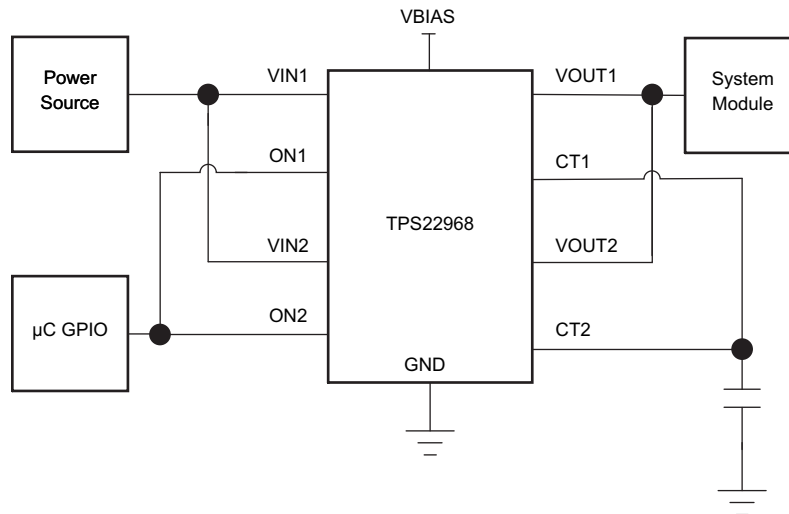
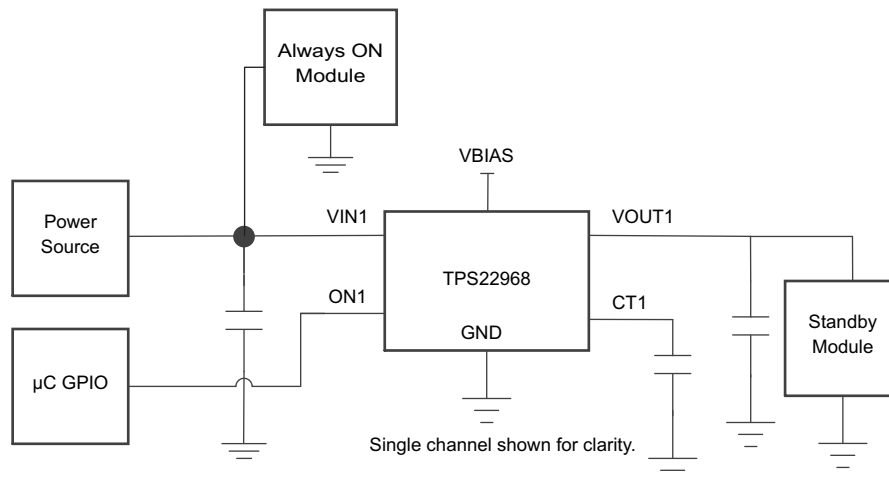

Figure 31. Parallel Configuration

## Application Information (continued)

### 10.1.2 Standby Power Reduction

Any end equipment that is powered from the battery has a need to reduce current consumption to keep the battery charged for a longer time. TPS22968 helps to accomplish this by turning off the supply to the modules that are in standby state, and therefore, significantly reduces the leakage current overhead of the standby modules. See [Figure 32](#).



**Figure 32. Standby Power Reduction**

### 10.1.3 Power Supply Sequencing Without a GPIO Input

In many end equipments, there is a need to power up various modules in a predetermined manner. The TPS22968 can solve the problem of power sequencing without adding any complexity to the overall system. See [Figure 33](#).

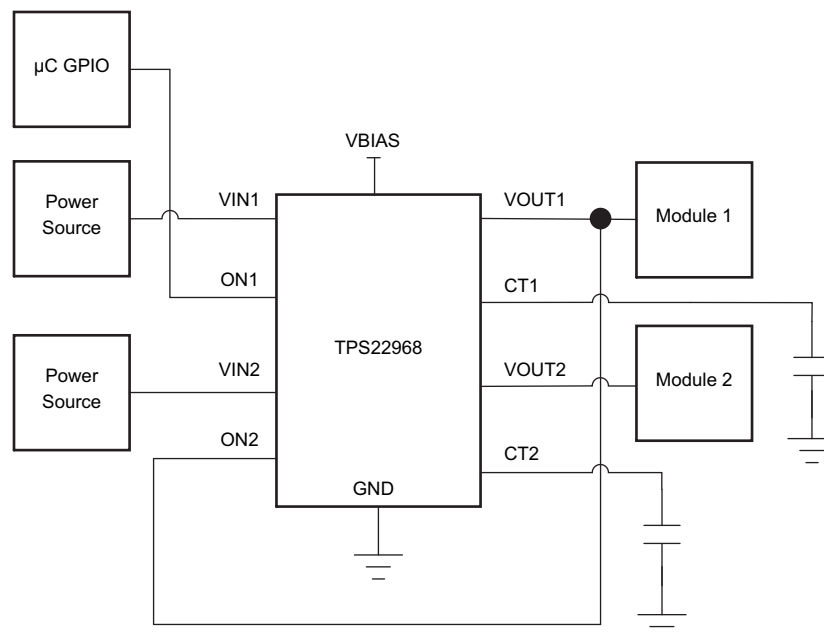

VIN1 must be greater  $V_{IH}$ .

**Figure 33. Power Sequencing Without a GPIO Input**

## Application Information (continued)

### 10.1.4 Reverse Current Blocking

In certain applications, it may be desirable to have reverse current blocking. Reverse current blocking prevents current from flowing from the output to the input of the load switch when the device is disabled. With the following configuration, the TPS22968 can be converted into a single-channel switch with reverse current blocking. In this configuration, VIN1 or VIN2 can be used as the input and VIN2 or VIN1 is the output. See [Figure 34](#).

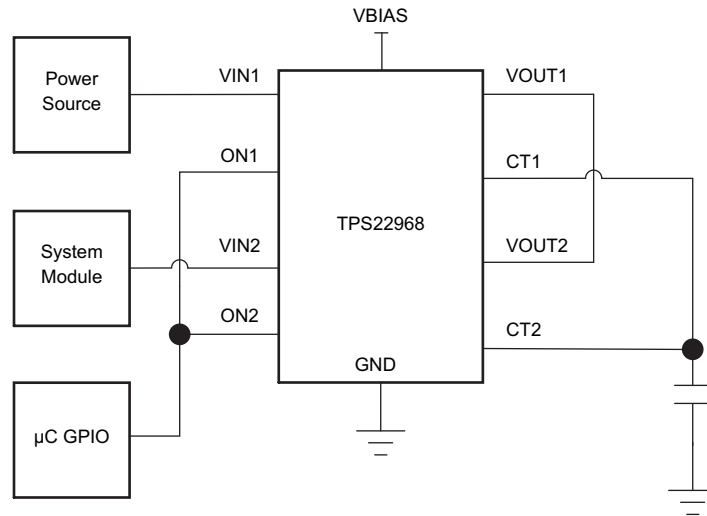

**Figure 34. Reverse Current Blocking**

## 10.2 Typical Application

This application demonstrates how the TPS22968 can be used to power downstream modules with large capacitances. The example in [Figure 35](#) TPS22968 is powering a 100- $\mu$ F capacitive output load.

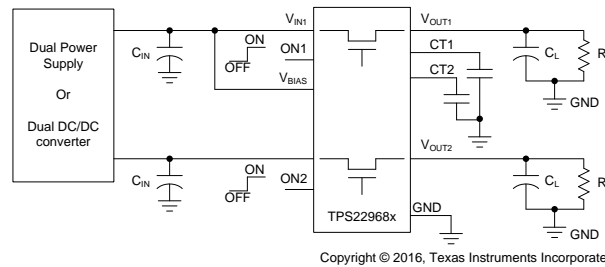

Copyright © 2016, Texas Instruments Incorporated

**Figure 35. Typical Application Schematic for Powering a Downstream Module**

### 10.2.1 Design Requirements

For this design example, use the following [Table 3](#) as the input parameters.

**Table 3. Design Parameters**

DESIGN PARAMETER	EXAMPLE VALUE
$V_{IN}$	3.3 V
$V_{BIAS}$	5 V
Load current	4 A
Output capacitance ( $C_L$ )	22 $\mu$ F
Allowable inrush current on VOUT	0.33 A

### 10.2.2 Detailed Design Procedure

To begin the design process, the designer must know the following:

- $V_{IN}$  voltage
- $V_{BIAS}$  voltage
- Load current
- Allowable inrush current on VOUT due to  $C_L$  capacitor

#### 10.2.2.1 $V_{IN}$ to $V_{OUT}$ Voltage Drop

The  $V_{IN}$  to  $V_{OUT}$  voltage drop in the device is determined by the  $R_{ON}$  of the device and the load current. The  $R_{ON}$  of the device depends upon the  $V_{IN}$  and  $V_{BIAS}$  conditions of the device. Refer to the  $R_{ON}$  specification of the device in the [Electrical Characteristics \( \$V\_{BIAS} = 5\$  V\)](#) and [Electrical Characteristics \( \$V\_{BIAS} = 2.5\$  V\)](#). After the  $R_{ON}$  of the device is determined based upon the  $V_{IN}$  and  $V_{BIAS}$  conditions, use [Equation 2](#) to calculate the  $V_{IN}$  to  $V_{OUT}$  voltage drop:

$$\Delta V = I_{LOAD} \times R_{ON}$$

where

- $\Delta V$  is the voltage drop from  $V_{IN}$  to  $V_{OUT}$
  - $I_{LOAD}$  is the load current
  - $R_{ON}$  is the On-resistance of the device for a specific  $V_{IN}$  and  $V_{BIAS}$  combination
- (2)

An appropriate  $I_{LOAD}$  must be chosen such that the  $I_{MAX}$  specification of the device is not violated.

#### 10.2.2.2 Inrush Current

To determine how much inrush current is caused by the  $C_L$  capacitor, use [Equation 3](#).

$$I_{INRUSH} = C_L \times \frac{dV_{OUT}}{dt}$$

where

- $I_{\text{INRUSH}}$  is the amount of inrush caused by  $C_L$
- $C_L$  is the capacitance on  $V_{\text{OUT}}$
- $dt$  is the time it takes for change in  $V_{\text{OUT}}$  during the ramp up of  $V_{\text{OUT}}$  when the device is enabled
- $dV_{\text{OUT}}$  is the change in  $V_{\text{OUT}}$  during the ramp up of  $V_{\text{OUT}}$  when the device is enabled

(3)

The device offers adjustable rise time for  $V_{\text{OUT}}$ . This feature allows the user to control the inrush current during turnon through the CTx pins. The appropriate rise time can be calculated using the design requirements and the inrush current equation ( [Equation 3](#)). See [Equation 4](#) and [Equation 5](#).

$$330 \text{ mA} = 22 \text{ } \mu\text{F} \times 3.3 \text{ V} / dt \quad (4)$$

$$dt = 220 \text{ } \mu\text{s} \quad (5)$$

To ensure an inrush current of less than 330 mA, choose a CT based on [Table 1](#) or [Equation 1](#) value that yields a rise time of more than 220  $\mu\text{s}$ . See the oscilloscope captures in the [Application Curves](#) for an example of how the CT capacitor can be used to reduce inrush current. See [Table 1](#) for correlation between rise times and CT values.

An appropriate  $C_L$  value must be placed on  $V_{\text{OUT}}$  such that the  $I_{\text{MAX}}$  and  $I_{\text{PLS}}$  specifications of the device are not violated.

### 10.2.2.3 Thermal Considerations

The maximum IC junction temperature must be restricted to 125°C under normal operating conditions. To calculate the maximum allowable dissipation,  $P_{\text{D(max)}}$  for a given output current and ambient temperature, use [Equation 6](#).

$$P_{\text{D(MAX)}} = \frac{T_{\text{J(MAX)}} - T_{\text{A}}}{R_{\theta\text{JA}}}$$

where

- $P_{\text{D(max)}}$  is the maximum allowable power dissipation
- $T_{\text{J(max)}}$  is the maximum allowable junction temperature (125°C for the TPS22968)
- $T_{\text{A}}$  is the ambient temperature of the device
- $R_{\theta\text{JA}}$  is the junction to air thermal impedance. See the [Thermal Information](#) table. This parameter is highly dependent upon board layout.

(6)

[Equation 7](#) to [Equation 10](#) and [Equation 11](#) to [Equation 13](#) show two examples to determine how to use this information correctly:

For  $V_{\text{BIAS}} = 5 \text{ V}$ ,  $V_{\text{IN}} = 5 \text{ V}$ , the maximum ambient temperature with a 4-A load through each channel can be determined by using [Equation 7](#) to [Equation 10](#):

$$P_{\text{D}} = I^2 \times R \times 2 \text{ (multiplied by 2 because there are two channels)} \quad (7)$$

$$2 \times I^2 \times R = \frac{T_{\text{J(MAX)}} - T_{\text{A}}}{R_{\theta\text{JA}}} \quad (8)$$

$$T_{\text{A}} = T_{\text{J(MAX)}} - R_{\theta\text{JA}} \times 2 \times I^2 \times R \quad (9)$$

$$T_{\text{A}} = 125^\circ\text{C} - 62.5^\circ\text{C/W} \times 2 \times (4 \text{ A})^2 \times 27 \text{ m}\Omega = 71^\circ\text{C} \quad (10)$$

For  $V_{\text{BIAS}} = 5 \text{ V}$ ,  $V_{\text{IN}} = 5 \text{ V}$ , the maximum continuous current for an ambient temperature of 85°C with the same current flowing through each channel can be determined by using [Equation 11](#) to [Equation 13](#):

$$2 \times I^2 \times R = \frac{T_{\text{J(MAX)}} - T_{\text{A}}}{R_{\theta\text{JA}}} \quad (11)$$

$$I = \sqrt{\frac{T_{J(MAX)} - T_A}{2 \times R \times R_{\theta JA}}} \tag{12}$$

$$I = \sqrt{\frac{125^\circ\text{C} - 105^\circ\text{C}}{2 \times 27\text{m}\Omega \times 62.5^\circ\text{C/W}}} = 3.44 \text{ A per channel} \tag{13}$$

### 10.2.3 Application Curves

The twp scope captures show the usage of a CT capacitor in conjunction with the device. A higher CT value results in a slower rise and a lower inrush current.

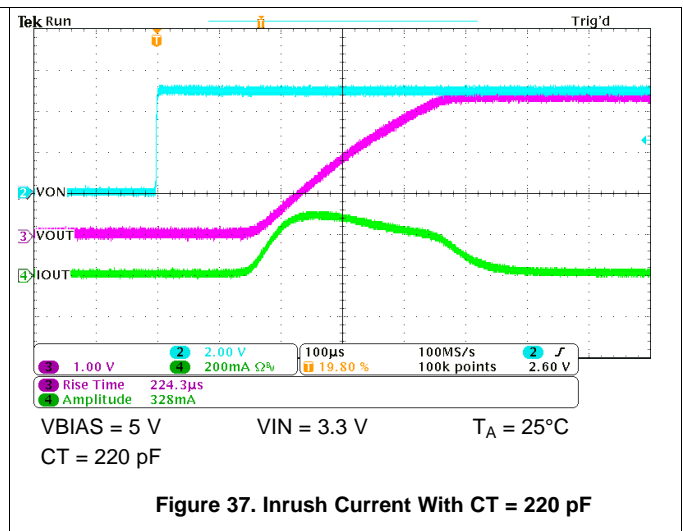
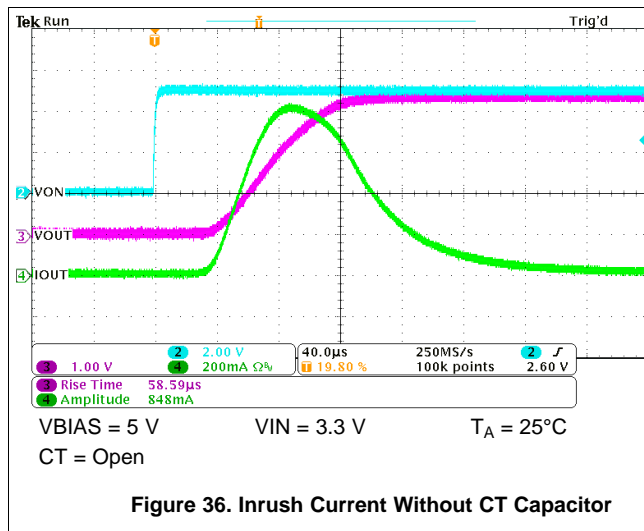

## 11 Power Supply Recommendations

The device is designed to operate from a  $V_{BIAS}$  range of 2.5 V to 5.5 V and  $V_{IN}$  range of 0.8 V to 5.5 V. This supply must be well regulated and placed as close to the device pin as possible with the recommended 1- $\mu$ F bypass capacitor. If the supply is located more than a few inches from the device pins, additional bulk capacitance may be required in addition to the ceramic bypass capacitors. If additional bulk capacitance is required, an electrolytic, tantalum, or ceramic capacitor of 10  $\mu$ F may be sufficient.

## 12 Layout

### 12.1 Layout Guidelines

- $V_{IN}$  and  $V_{OUT}$  traces must be as short and wide as possible to accommodate for high current.
- Use vias under the exposed thermal pad for thermal relief for high current operation.
- $V_{INx}$  pins must be bypassed to ground with low-ESR ceramic bypass capacitors. The typical recommended bypass capacitance is 1- $\mu$ F ceramic with X5R or X7R dielectric. This capacitor must be placed as close to the device pins as possible.
- $V_{OUTx}$  pins must be bypassed to ground with low-ESR ceramic bypass capacitors. The typical recommended bypass capacitance is one-tenth of the  $V_{INx}$  bypass capacitor of X5R or X7R dielectric rating. This capacitor must be placed as close to the device pins as possible.
- The  $V_{BIAS}$  pin must be bypassed to ground with low-ESR ceramic bypass capacitors. The typical recommended bypass capacitance is 0.1- $\mu$ F ceramic with X5R or X7R dielectric.
- The  $CTx$  capacitors must be placed as close to the device pins as possible. The typical recommended  $CTx$  capacitance is a capacitor of X5R or X7R dielectric rating with a rating of 25 V or higher.

### 12.2 Layout Example

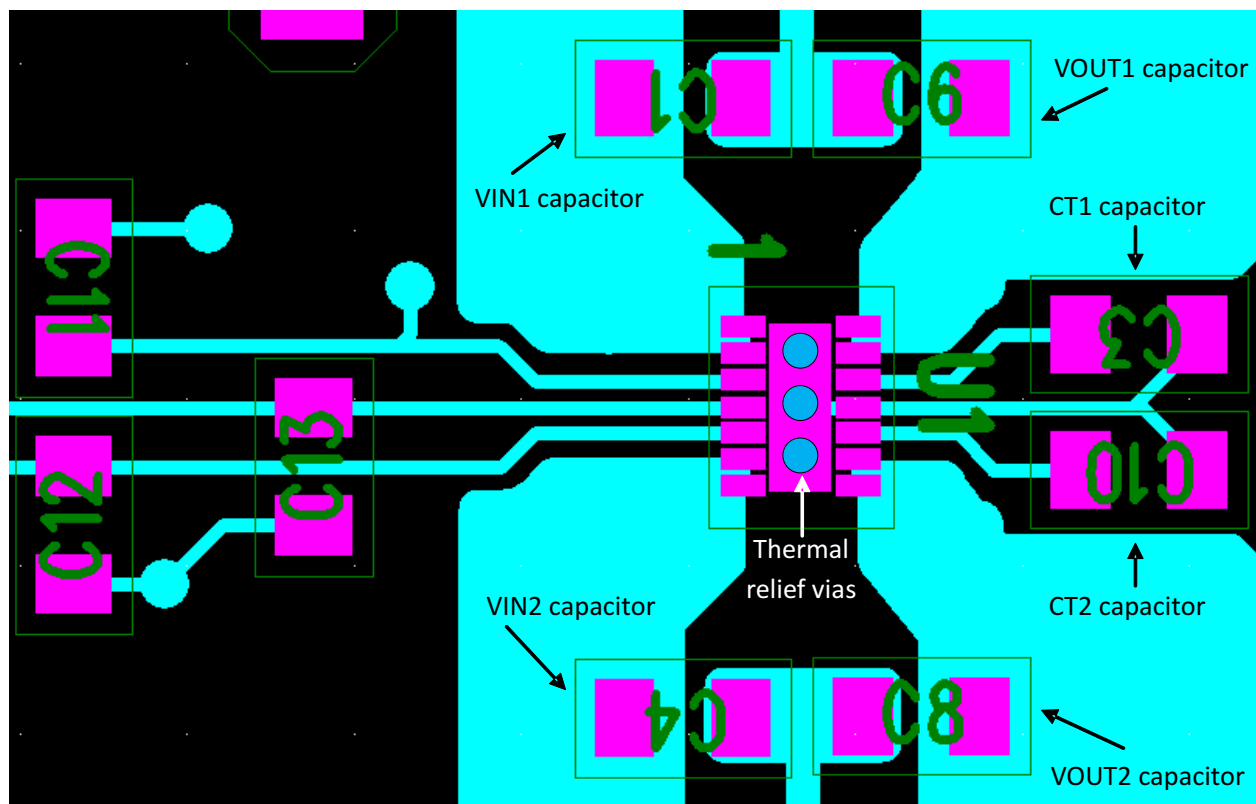

## 13 Device and Documentation Support

### 13.1 Device Support

#### 13.1.1 Development Support

For the TPS22968 and TPS22968-Q1 PSpice Transient Model, see [SLVMA29](#).

For the TPS22968N and TPS22968N-Q1 PSpice Transient Model, see [SLVMBA9](#).

### 13.2 Documentation Support

#### 13.2.1 Related Documentation

For related documentation see the following:

- *Managing Inrush Current*, [SLVA670A](#)
- *Quiescent Current vs Shutdown Current for Load Switch Power Consumption*, [SLVA757](#)
- *TPS22968EVM-007 Dual 4A Load Switch*, [SLVUA30](#)
- *Load Switch Thermal Considerations*, [SLVUA74](#)
- *TPS22968/68N-Q1 Dual-Channel 5.5-V 4-A 27-mΩ Load Switch EVM User's Guide*, [SLVUAE2A](#)
- *TPS22968NEVM Dual 4 A Load Switch*, [SLVUAL0](#)

### 13.3 Related Links

The table below lists quick access links. Categories include technical documents, support and community resources, tools and software, and quick access to sample or buy.

**Table 4. Related Links**

PARTS	PRODUCT FOLDER	SAMPLE & BUY	TECHNICAL DOCUMENTS	TOOLS & SOFTWARE	SUPPORT & COMMUNITY
TPS22968	<a href="#">Click here</a>	<a href="#">Click here</a>	<a href="#">Click here</a>	<a href="#">Click here</a>	<a href="#">Click here</a>
TPS22968N	<a href="#">Click here</a>	<a href="#">Click here</a>	<a href="#">Click here</a>	<a href="#">Click here</a>	<a href="#">Click here</a>

### 13.4 Receiving Notification of Documentation Updates

To receive notification of documentation updates, navigate to the device product folder on [ti.com](http://ti.com). In the upper right corner, click on *Alert me* to register and receive a weekly digest of any product information that has changed. For change details, review the revision history included in any revised document.

### 13.5 Community Resources

The following links connect to TI community resources. Linked contents are provided "AS IS" by the respective contributors. They do not constitute TI specifications and do not necessarily reflect TI's views; see TI's [Terms of Use](#).

**TI E2E™ Online Community** *TI's Engineer-to-Engineer (E2E) Community*. Created to foster collaboration among engineers. At [e2e.ti.com](http://e2e.ti.com), you can ask questions, share knowledge, explore ideas and help solve problems with fellow engineers.

**Design Support** *TI's Design Support* Quickly find helpful E2E forums along with design support tools and contact information for technical support.

### 13.6 Trademarks

E2E is a trademark of Texas Instruments.

Ultrabook is a trademark of Intel.

### 13.7 Electrostatic Discharge Caution



This integrated circuit can be damaged by ESD. Texas Instruments recommends that all integrated circuits be handled with appropriate precautions. Failure to observe proper handling and installation procedures can cause damage.

ESD damage can range from subtle performance degradation to complete device failure. Precision integrated circuits may be more susceptible to damage because very small parametric changes could cause the device not to meet its published specifications.

### 13.8 Glossary

[SLYZ022](#) — *TI Glossary*.

This glossary lists and explains terms, acronyms, and definitions.

## 14 Mechanical, Packaging, and Orderable Information

The following pages include mechanical, packaging, and orderable information. This information is the most current data available for the designated devices. This data is subject to change without notice and revision of this document. For browser-based versions of this data sheet, refer to the left-hand navigation.

**PACKAGING INFORMATION**

Orderable Device	Status (1)	Package Type	Package Drawing	Pins	Package Qty	Eco Plan (2)	Lead/Ball Finish (6)	MSL Peak Temp (3)	Op Temp (°C)	Device Marking (4/5)	Samples
TPS22968DPUR	ACTIVE	WSON	DPU	14	3000	Green (RoHS & no Sb/Br)	CU NIPDAU	Level-2-260C-1 YEAR	-40 to 105	RB968	<a href="#">Samples</a>
TPS22968DPUT	ACTIVE	WSON	DPU	14	250	Green (RoHS & no Sb/Br)	CU NIPDAU	Level-2-260C-1 YEAR	-40 to 105	RB968	<a href="#">Samples</a>
TPS22968NDPUR	ACTIVE	WSON	DPU	14	3000	Green (RoHS & no Sb/Br)	CU NIPDAU	Level-2-260C-1 YEAR	-40 to 105	RB968N	<a href="#">Samples</a>
TPS22968NDPUT	ACTIVE	WSON	DPU	14	250	Green (RoHS & no Sb/Br)	CU NIPDAU	Level-2-260C-1 YEAR	-40 to 105	RB968N	<a href="#">Samples</a>

(1) The marketing status values are defined as follows:

**ACTIVE:** Product device recommended for new designs.

**LIFEBUY:** TI has announced that the device will be discontinued, and a lifetime-buy period is in effect.

**NRND:** Not recommended for new designs. Device is in production to support existing customers, but TI does not recommend using this part in a new design.

**PREVIEW:** Device has been announced but is not in production. Samples may or may not be available.

**OBSOLETE:** TI has discontinued the production of the device.

(2) **RoHS:** TI defines "RoHS" to mean semiconductor products that are compliant with the current EU RoHS requirements for all 10 RoHS substances, including the requirement that RoHS substance do not exceed 0.1% by weight in homogeneous materials. Where designed to be soldered at high temperatures, "RoHS" products are suitable for use in specified lead-free processes. TI may reference these types of products as "Pb-Free".

**RoHS Exempt:** TI defines "RoHS Exempt" to mean products that contain lead but are compliant with EU RoHS pursuant to a specific EU RoHS exemption.

**Green:** TI defines "Green" to mean the content of Chlorine (Cl) and Bromine (Br) based flame retardants meet JS709B low halogen requirements of <=1000ppm threshold. Antimony trioxide based flame retardants must also meet the <=1000ppm threshold requirement.

(3) MSL, Peak Temp. - The Moisture Sensitivity Level rating according to the JEDEC industry standard classifications, and peak solder temperature.

(4) There may be additional marking, which relates to the logo, the lot trace code information, or the environmental category on the device.

(5) Multiple Device Markings will be inside parentheses. Only one Device Marking contained in parentheses and separated by a "-" will appear on a device. If a line is indented then it is a continuation of the previous line and the two combined represent the entire Device Marking for that device.

(6) Lead/Ball Finish - Orderable Devices may have multiple material finish options. Finish options are separated by a vertical ruled line. Lead/Ball Finish values may wrap to two lines if the finish value exceeds the maximum column width.

**Important Information and Disclaimer:** The information provided on this page represents TI's knowledge and belief as of the date that it is provided. TI bases its knowledge and belief on information provided by third parties, and makes no representation or warranty as to the accuracy of such information. Efforts are underway to better integrate information from third parties. TI has taken and

continues to take reasonable steps to provide representative and accurate information but may not have conducted destructive testing or chemical analysis on incoming materials and chemicals. TI and TI suppliers consider certain information to be proprietary, and thus CAS numbers and other limited information may not be available for release.

In no event shall TI's liability arising out of such information exceed the total purchase price of the TI part(s) at issue in this document sold by TI to Customer on an annual basis.

**OTHER QUALIFIED VERSIONS OF TPS22968 :**

- Automotive: [TPS22968-Q1](#)

**NOTE: Qualified Version Definitions:**

- Automotive - Q100 devices qualified for high-reliability automotive applications targeting zero defects

**TAPE AND REEL INFORMATION**

**QUADRANT ASSIGNMENTS FOR PIN 1 ORIENTATION IN TAPE**

\*All dimensions are nominal

Device	Package Type	Package Drawing	Pins	SPQ	Reel Diameter (mm)	Reel Width W1 (mm)	A0 (mm)	B0 (mm)	K0 (mm)	P1 (mm)	W (mm)	Pin1 Quadrant
TPS22968DPUR	WSO	DPU	14	3000	180.0	8.4	2.25	3.25	1.05	4.0	8.0	Q1
TPS22968DPUR	WSO	DPU	14	3000	180.0	8.4	2.25	3.25	1.05	4.0	8.0	Q1
TPS22968DPUT	WSO	DPU	14	250	180.0	8.4	2.25	3.25	1.05	4.0	8.0	Q1
TPS22968DPUT	WSO	DPU	14	250	180.0	8.4	2.25	3.25	1.05	4.0	8.0	Q1
TPS22968NDPUR	WSO	DPU	14	3000	180.0	8.4	2.25	3.25	1.05	4.0	8.0	Q1
TPS22968NDPUT	WSO	DPU	14	250	180.0	8.4	2.25	3.25	1.05	4.0	8.0	Q1

**TAPE AND REEL BOX DIMENSIONS**

\*All dimensions are nominal

Device	Package Type	Package Drawing	Pins	SPQ	Length (mm)	Width (mm)	Height (mm)
TPS22968DPUR	WSON	DPU	14	3000	210.0	185.0	35.0
TPS22968DPUR	WSON	DPU	14	3000	210.0	185.0	35.0
TPS22968DPUT	WSON	DPU	14	250	210.0	185.0	35.0
TPS22968DPUT	WSON	DPU	14	250	210.0	185.0	35.0
TPS22968NDPUR	WSON	DPU	14	3000	210.0	185.0	35.0
TPS22968NDPUT	WSON	DPU	14	250	210.0	185.0	35.0

DPU (R-PWSON-N14)

PLASTIC SMALL OUTLINE NO-LEAD

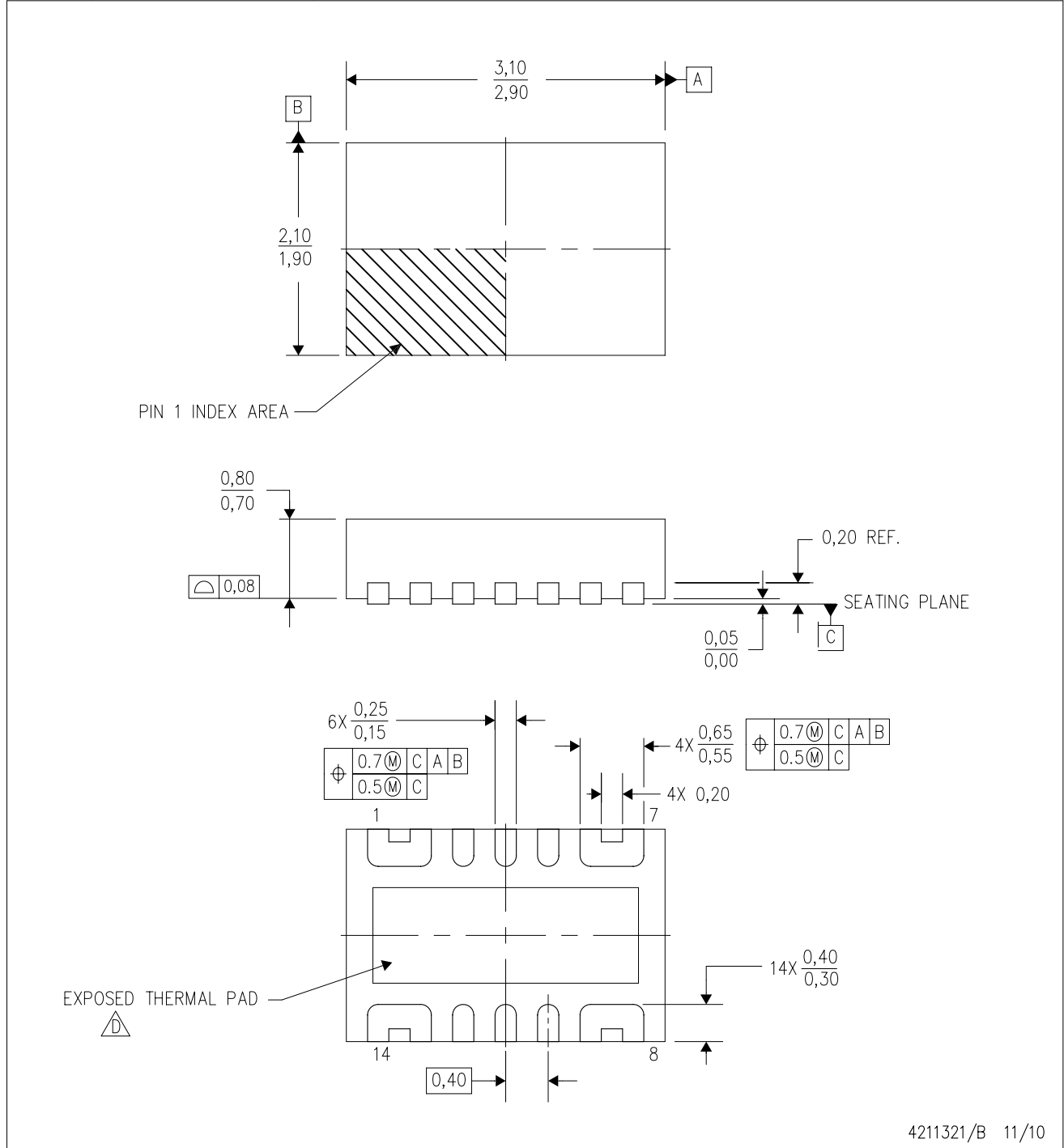

- NOTES:
- All linear dimensions are in millimeters. Dimensioning and tolerancing per ASME Y14.5M-1994.
  - This drawing is subject to change without notice.
  - Small Outline No-Lead (SON) package configuration.
  - The package thermal pad must be soldered to the board for thermal and mechanical performance. See the Product Data Sheet for details regarding the exposed thermal pad dimensions.
  - This package is Pb-free.

## THERMAL PAD MECHANICAL DATA

DPU (R-PWSON-N14)

PLASTIC SMALL OUTLINE NO-LEAD

### THERMAL INFORMATION

This package incorporates an exposed thermal pad that is designed to be attached directly to an external heatsink. The thermal pad must be soldered directly to the printed circuit board (PCB). After soldering, the PCB can be used as a heatsink. In addition, through the use of thermal vias, the thermal pad can be attached directly to the appropriate copper plane shown in the electrical schematic for the device, or alternatively, can be attached to a special heatsink structure designed into the PCB. This design optimizes the heat transfer from the integrated circuit (IC).

For information on the Quad Flatpack No-Lead (QFN) package and its advantages, refer to Application Report, QFN/SON PCB Attachment, Texas Instruments Literature No. SLUA271. This document is available at [www.ti.com](http://www.ti.com).

The exposed thermal pad dimensions for this package are shown in the following illustration.

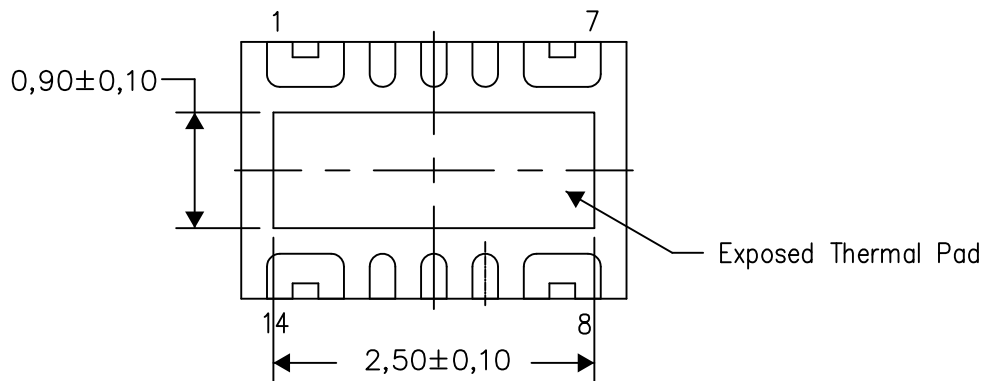

Bottom View

Exposed Thermal Pad Dimensions

4211395/C 04/15

NOTE: All linear dimensions are in millimeters

DPU (R-PWSON-N14)

PLASTIC SMALL OUTLINE NO-LEAD

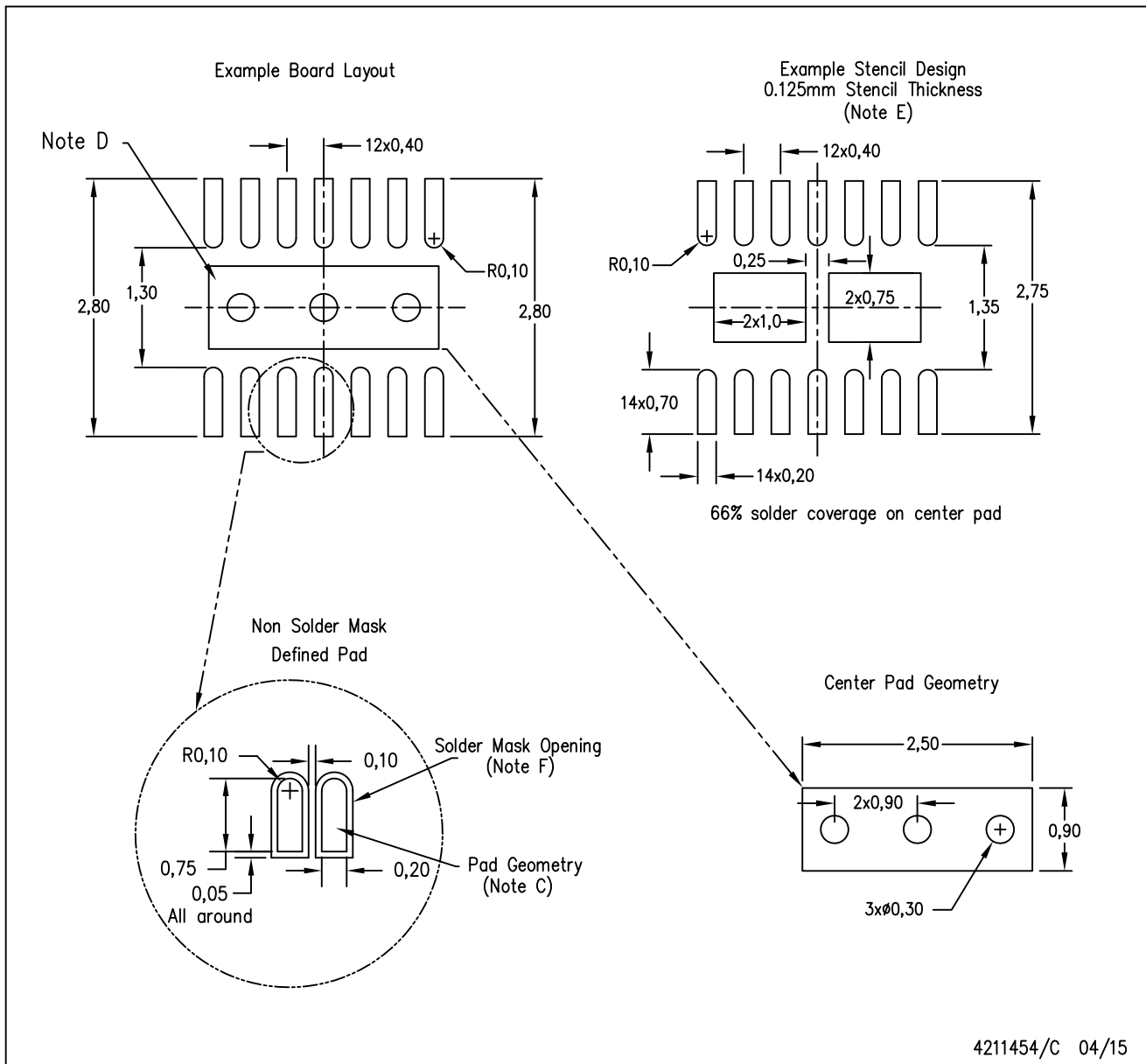

4211454/C 04/15

- NOTES:
- All linear dimensions are in millimeters.
  - This drawing is subject to change without notice.
  - Publication IPC-7351 is recommended for alternate designs.
  - This package is designed to be soldered to a thermal pad on the board. Refer to Application Note, QFN/SON PCB Attachment, Texas Instruments Literature No. SLUA271, and also the Product Data Sheets for specific thermal information, via requirements, and recommended board layout. These documents are available at [www.ti.com](http://www.ti.com) <<http://www.ti.com>>.
  - Laser cutting apertures with trapezoidal walls and also rounding corners will offer better paste release. Customers should contact their board assembly site for stencil design recommendations. Refer to IPC 7525 for stencil design considerations.
  - Customers should contact their board fabrication site for minimum solder mask web tolerances between signal pads.

## IMPORTANT NOTICE AND DISCLAIMER

TI PROVIDES TECHNICAL AND RELIABILITY DATA (INCLUDING DATASHEETS), DESIGN RESOURCES (INCLUDING REFERENCE DESIGNS), APPLICATION OR OTHER DESIGN ADVICE, WEB TOOLS, SAFETY INFORMATION, AND OTHER RESOURCES "AS IS" AND WITH ALL FAULTS, AND DISCLAIMS ALL WARRANTIES, EXPRESS AND IMPLIED, INCLUDING WITHOUT LIMITATION ANY IMPLIED WARRANTIES OF MERCHANTABILITY, FITNESS FOR A PARTICULAR PURPOSE OR NON-INFRINGEMENT OF THIRD PARTY INTELLECTUAL PROPERTY RIGHTS.

These resources are intended for skilled developers designing with TI products. You are solely responsible for (1) selecting the appropriate TI products for your application, (2) designing, validating and testing your application, and (3) ensuring your application meets applicable standards, and any other safety, security, or other requirements. These resources are subject to change without notice. TI grants you permission to use these resources only for development of an application that uses the TI products described in the resource. Other reproduction and display of these resources is prohibited. No license is granted to any other TI intellectual property right or to any third party intellectual property right. TI disclaims responsibility for, and you will fully indemnify TI and its representatives against, any claims, damages, costs, losses, and liabilities arising out of your use of these resources.

TI's products are provided subject to TI's Terms of Sale ([www.ti.com/legal/termsofsale.html](http://www.ti.com/legal/termsofsale.html)) or other applicable terms available either on [ti.com](http://ti.com) or provided in conjunction with such TI products. TI's provision of these resources does not expand or otherwise alter TI's applicable warranties or warranty disclaimers for TI products.

Mailing Address: Texas Instruments, Post Office Box 655303, Dallas, Texas 75265  
Copyright © 2019, Texas Instruments Incorporated

## Looking for pricing, stock, or lifecycle information?

Click below to explore more details on WIN SOURCE:

 [View TPS22968DPUT on WIN SOURCE](#)

 [Texas Instruments](#) Information

## Optimize Your Supply Chain with WIN SOURCE Solutions

-  Global Sourcing Solution
-  Obsolete Management
-  Cost Control Management
-  Shortage Management
-  Alternative Solution
-  Excess Inventory Management