



**THE DATASHEET OF
TPS22961DNYT**



TPS22961 3.5-V, 6-A, Ultra-low Resistance Load Switch

1 Features

- Integrated Single Channel Load Switch
- VBIAS Voltage Range: 3 V to 5.5 V
- Input Voltage Range: 0.8 V to 3.5 V
- Ultra low R_{ON} Resistance
 - $R_{ON} = 4.4 \text{ m}\Omega$ at $V_{IN} = 1.05 \text{ V}$ ($V_{BIAS} = 5 \text{ V}$)
- 6A Maximum Continuous Switch Current
- Low Quiescent Current $< 1 \mu\text{A}$ (max)
- Low Control Input Threshold Enables use of 1.2-V/1.8-V/2.5-V/3.3-V Logic
- Controlled Slew Rate
 - $t_R = 4.2 \mu\text{s}$ at $V_{IN} = 1.05 \text{ V}$ ($V_{BIAS} = 5 \text{ V}$)
- Quick Output Discharge (QOD)
- SON 8-terminal Package with Thermal Pad
- ESD Performance Tested per JESD 22
 - 2-kV HBM and 1-kV CDM

2 Applications

- Ultrabook™/Notebooks
- Desktops
- Servers
- Set-top Boxes
- Telecom Systems
- Tablet PC

3 Description

The TPS22961 is a small, ultra-low R_{ON} , single channel load switch with controlled turn on. The device contains an N-channel MOSFET that can operate over an input voltage range of 0.8 V to 3.5 V and supports a maximum continuous current of 6 A.

The combination of ultra-low R_{ON} and high current capability of the device makes it ideal for driving processor rails with very tight voltage dropout tolerances. Quick rise time of the device allows for power rails to come up quickly when the device is enabled, thereby reducing response time for power distribution. The switch can be independently controlled via the ON terminal, which is capable of interfacing directly with low-voltage control signals originating from microcontrollers or low voltage discrete logic. The device further reduces the total solution size by integrating a 260 Ω pull-down transistor for quick output discharge (QOD) when the switch is turned off.

The TPS22961 is available in a small, space-saving 3 mm x 3 mm 8-SON package (DNY) with integrated thermal pad allowing for high power dissipation. The device is characterized for operation over the free-air temperature range of -40°C to 85°C .

Device Information⁽¹⁾

PART NUMBER	PACKAGE	BODY SIZE
TPS22961	WSON (8)	3.00 mm x 3.00 mm

(1) For all available packages, see the orderable addendum at the end of the datasheet.

4 Simplified Schematic

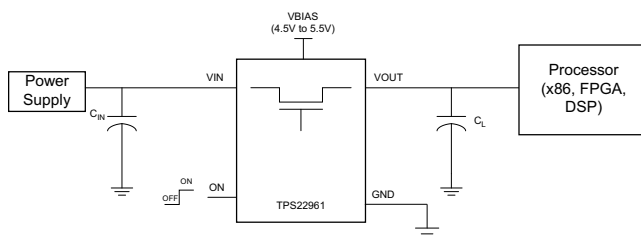

Typical Application: driving high current core rails for a processor

R_{ON} vs V_{IN} ($V_{BIAS} = 5 \text{ V}$, $I_{OUT} = -200 \text{ mA}$)

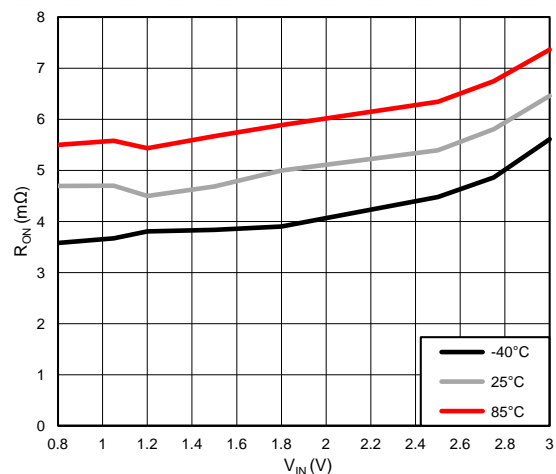

Table of Contents

1 Features	1	8.1 Overview	12
2 Applications	1	8.2 Functional Block Diagram	12
3 Description	1	8.3 Feature Description	13
4 Simplified Schematic	1	9 Applications and Implementation	14
5 Revision History	2	9.1 Application Information	14
6 Terminal Configuration and Functions	3	9.2 Typical Application	14
7 Specifications	3	10 Power Supply Recommendations	18
7.1 Absolute Maximum Ratings	3	11 Layout	19
7.2 Handling Ratings	4	11.1 Layout Guidelines	19
7.3 Recommended Operating Conditions	4	11.2 Layout Example	19
7.4 Thermal Information	4	12 Device and Documentation Support	20
7.5 Electrical Characteristics, $V_{BIAS} = 5.0\text{ V}$	5	12.1 Trademarks	20
7.6 Electrical Characteristics, $V_{BIAS} = 3.0\text{ V}$	5	12.2 Electrostatic Discharge Caution	20
7.7 Switching Characteristics	6	12.3 Glossary	20
7.8 Typical Characteristics	8	13 Mechanical, Packaging, and Orderable Information	20
8 Detailed Description	12		

5 Revision History

Changes from Revision A (February 2014) to Revision B	Page
• Fixed caption error in Filtered Output curve.	18

Changes from Original (February 2014) to Revision A	Page
• Initial release of full version.	1

6 Terminal Configuration and Functions

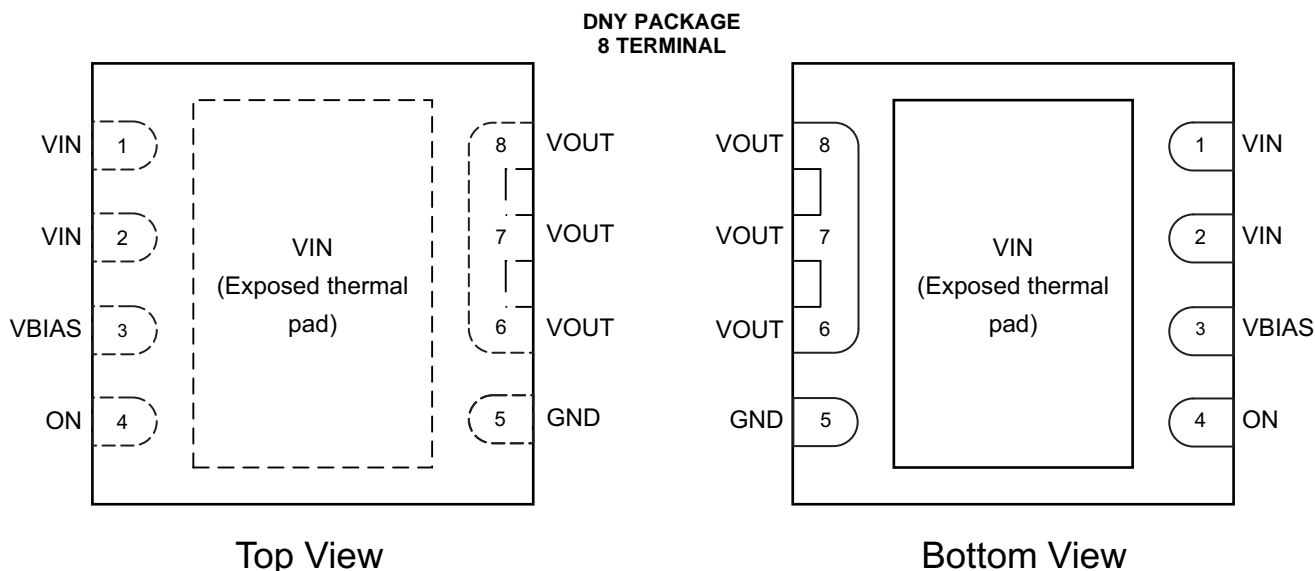

Pin Functions

PIN		I/O	DESCRIPTION
NAME	NO.		
VIN	1, 2	I	Switch input. Place ceramic bypass capacitor(s) between this terminal and GND. See Detailed Description section for more information.
VIN	Exposed thermal Pad	I	Switch input. Place ceramic bypass capacitor(s) between this terminal and GND. See Detailed Description section for more information.
VBIAS	3	I	Bias voltage. Power supply to the device.
ON	4	I	Active high switch control input. Do not leave floating.
GND	5	–	Ground.
VOUT	6, 7, 8	O	Switch output. Place ceramic bypass capacitor(s) between this terminal and GND. See Detailed Description section for more information.

7 Specifications

7.1 Absolute Maximum Ratings

Over operating free-air temperature range (unless otherwise noted)⁽¹⁾

		MIN	MAX	UNIT
V_{IN}	Input voltage range	–0.3	4	V
V_{BIAS}	Bias voltage range	–0.3	6	V
V_{OUT}	Output voltage range	–0.3	4	V
V_{ON}	ON pin voltage range	–0.3	6	V
I_{MAX}	Maximum Continuous Switch Current		6	A
I_{PLS}	Maximum Pulsed Switch Current, pulse < 300 μ s, 2% duty cycle		8	A
T_A	Operating free-air temperature range	–40	85	°C
T_J	Maximum junction temperature		125	°C

- (1) Stresses beyond those listed under [Absolute Maximum Ratings](#) may cause permanent damage to the device. These are stress ratings only, which do not imply functional operation of the device at these or any other conditions beyond those indicated under [Recommended Operating Conditions](#). Exposure to absolute-maximum-rated conditions for extended periods may affect device reliability.

7.2 Handling Ratings

		MIN	MAX	UNIT
T _{STG}	Storage temperature range	-65	150	°C
T _{LEAD}	Maximum lead temperature (10-s soldering time)		300	°C
V _{ESD} ⁽¹⁾	Human-Body Model (HBM) ⁽²⁾		2	kV
	Charged-Device Model (CDM) ⁽³⁾		1	kV

- (1) Electrostatic discharge (ESD) to measure device sensitivity and immunity to damage caused by assembly line electrostatic discharges in to the device.
- (2) Level listed above is the passing level per ANSI, ESDA, and JEDEC JS-001. JEDEC document JEP155 states that 500-V HBM allows safe manufacturing with a standard ESD control process.
- (3) Level listed above is the passing level per EIA-JEDEC JESD22-C101. JEDEC document JEP157 states that 250-V CDM allows safe manufacturing with a standard ESD control process.

7.3 Recommended Operating Conditions

Over operating free-air temperature range (unless otherwise noted)

		MIN	MAX	UNIT		
V _{IN}	Input voltage range	0.8	V _{BIAS} – 1.95	V		
V _{BIAS}	Bias voltage range	3	5.5	V		
V _{ON}	ON voltage range	0	5.5	V		
V _{OUT}	Output voltage range		V _{IN}	V		
V _{IH, ON}	High-level voltage, ON	V _{BIAS} = 3 V to 5.5 V		1.2	5.5	V
V _{IL, ON}	Low-level voltage, ON	V _{BIAS} = 3 V to 5.5 V		0	0.5	V
C _{IN}	Input Capacitor	1 ⁽¹⁾			μF	

- (1) Refer to [Detailed Description](#) section.

7.4 Thermal Information

THERMAL METRIC ⁽¹⁾		TPS22961		UNIT
		DNY		
		8 PINS		
θ _{JA}	Junction-to-ambient thermal resistance	44.6		°C/W
θ _{JCtop}	Junction-to-case (top) thermal resistance	44.4		
θ _{JB}	Junction-to-board thermal resistance	17.6		
ψ _{JT}	Junction-to-top characterization parameter	0.4		
ψ _{JB}	Junction-to-board characterization parameter	17.4		
θ _{JCbot}	Junction-to-case (bottom) thermal resistance	1.1		

- (1) For more information about traditional and new thermal metrics, see the *IC Package Thermal Metrics* application report, [SPRA953](#).

7.5 Electrical Characteristics, $V_{BIAS} = 5.0\text{ V}$

Unless otherwise noted, the specification in the following table applies over the operating ambient temperature $-40^{\circ}\text{C} \leq T_A \leq 85^{\circ}\text{C}$ (full) and $V_{BIAS} = 5.0\text{ V}$. Typical values are for $T_A = 25^{\circ}\text{C}$ (unless otherwise noted).

PARAMETER		TEST CONDITIONS	T_A	MIN	TYP	MAX	UNIT
POWER SUPPLIES AND CURRENTS							
$I_{Q, V_{BIAS}}$	V_{BIAS} quiescent current	$I_{OUT} = 0, V_{IN} = 3\text{ V}, V_{ON} = V_{BIAS} = 5.0\text{ V}$	Full		0.6	1	μA
$I_{SD, V_{BIAS}}$	V_{BIAS} shutdown current	$V_{ON} = 0\text{ V}, V_{OUT} = 0\text{ V}$	Full		0.6	1	μA
$I_{SD, V_{IN}}$	V_{IN} shutdown current	$V_{ON} = 0\text{ V}, V_{OUT} = 0\text{ V}$	Full	$V_{IN} = 3.0\text{ V}$	0.0009	0.1	μA
				$V_{IN} = 2.5\text{ V}$	0.0008	0.1	
				$V_{IN} = 2.0\text{ V}$	0.0007	0.1	
				$V_{IN} = 1.05\text{ V}$	0.0007	0.1	
				$V_{IN} = 0.8\text{ V}$	0.0006	0.1	
I_{ON}	ON terminal input leakage current	$V_{ON} = 5.5\text{ V}$	Full			0.1	μA
RESISTANCE CHARACTERISTICS							
R_{ON}	ON-state resistance	$I_{OUT} = -200\text{ mA}, V_{BIAS} = 5.0\text{ V}$	$V_{IN} = 3.0\text{ V}$	25°C	6.5	8	$\text{m}\Omega$
				Full		8.8	
			$V_{IN} = 2.5\text{ V}$	25°C	5.3	6.3	$\text{m}\Omega$
				Full		7.2	
			$V_{IN} = 2.0\text{ V}$	25°C	4.8	5.8	$\text{m}\Omega$
				Full		6.7	
			$V_{IN} = 1.05\text{ V}$	25°C	4.4	5.3	$\text{m}\Omega$
				Full		6.2	
			$V_{IN} = 0.8\text{ V}$	25°C	4.3	5.3	$\text{m}\Omega$
				Full		6.1	
R_{PD}	Output pulldown resistance	$V_{IN} = 5.0\text{ V}, V_{ON} = 0\text{ V}, V_{OUT} = 1\text{ V}$	Full		260	300	Ω

7.6 Electrical Characteristics, $V_{BIAS} = 3.0\text{ V}$

Unless otherwise noted, the specification in the following table applies over the operating ambient temperature $-40^{\circ}\text{C} \leq T_A \leq 85^{\circ}\text{C}$ (full) and $V_{BIAS} = 3.0\text{ V}$. Typical values are for $T_A = 25^{\circ}\text{C}$ unless otherwise noted.

PARAMETER		TEST CONDITIONS	T_A	MIN	TYP	MAX	UNIT
POWER SUPPLIES AND CURRENTS							
$I_{Q, V_{BIAS}}$	V_{BIAS} quiescent current	$I_{OUT} = 0, V_{IN} = 1\text{ V}, V_{ON} = V_{BIAS} = 3.0\text{ V}$	Full		0.3	1	μA
$I_{SD, V_{BIAS}}$	V_{BIAS} shutdown current	$V_{ON} = 0\text{ V}, V_{OUT} = 0\text{ V}$	Full		0.3	1	μA
$I_{SD, V_{IN}}$	V_{IN} shutdown current	$V_{ON} = 0\text{ V}, V_{OUT} = 0\text{ V}$	Full	$V_{IN} = 1.05\text{ V}$	0.001	0.1	μA
				$V_{IN} = 0.8\text{ V}$	0.0008	0.1	
I_{ON}	ON terminal input leakage current	$V_{ON} = 5.5\text{ V}$	Full			0.1	μA
RESISTANCE CHARACTERISTICS							
R_{ON}	ON-state resistance	$I_{OUT} = -200\text{ mA}, V_{BIAS} = 3.0\text{ V}$	$V_{IN} = 1.05\text{ V}$	25°C	6.7	8.4	$\text{m}\Omega$
				Full		9.2	
			$V_{IN} = 0.8\text{ V}$	25°C	5.8	7.0	$\text{m}\Omega$
				Full		7.9	
R_{PD}	Output pull-down resistance	$V_{IN} = 3\text{ V}, V_{ON} = 0\text{ V}, V_{OUT} = 1\text{ V}$	Full		260	300	Ω

7.7 Switching Characteristics

Refer to the timing test circuit in [Figure 1](#) (unless otherwise noted) for references to external components used for the test condition in the switching characteristics table.

PARAMETER		TEST CONDITION	MIN	TYP	MAX	UNIT	
$V_{IN} = 2.5\text{ V}$, $V_{ON} = V_{BIAS} = 5\text{ V}$, $T_A = 25^\circ\text{C}$ (unless otherwise noted)							
t_{ON}	Turn-on time	$R_L = 10\ \Omega$, $C_L = 0.1\ \mu\text{F}$		10.0		μs	
t_{OFF}	Turn-off time			3.5			
t_R	V_{OUT} rise time			6.3			
t_F	V_{OUT} fall time			2.0			
t_D	Delay time			8.1			
$V_{IN} = 1.05\text{ V}$, $V_{ON} = V_{BIAS} = 5\text{ V}$, $T_A = 25^\circ\text{C}$ (unless otherwise noted)							
t_{ON}	Turn-on time	$L = 2.2\ \mu\text{H}$ (DCR = 0.33 Ω), $C = 2 \times 22\ \mu\text{F}$ (Refer to Typical Application Powering Rails Sensitive to Ringing and Overvoltage due to Fast Rise Time and Figure 31)	8.1	11.3	17.3	μs	
t_{OFF}	Turn-off time			13700			
t_R	V_{OUT} rise time			5	9.5		12.5
t_F	V_{OUT} fall time			44200			
t_D	Delay time			6.7	9.3		12.5
$V_{IN} = 0.8\text{ V}$, $V_{ON} = V_{BIAS} = 5\text{ V}$, $T_A = 25^\circ\text{C}$ (unless otherwise noted)							
t_{ON}	Turn-on time	$R_L = 10\ \Omega$, $C_L = 0.1\ \mu\text{F}$		9.7		μs	
t_{OFF}	Turn-off time			6.0			
t_R	V_{OUT} rise time			3.2			
t_F	V_{OUT} fall time			1.8			
t_D	Delay time			8.1			
$V_{IN} = 1.05\text{ V}$, $V_{ON} = 5\text{ V}$, $V_{BIAS} = 3.0\text{ V}$, $T_A = 25^\circ\text{C}$ (unless otherwise noted)							
t_{ON}	Turn-on time	$R_L = 10\ \Omega$, $C_L = 0.1\ \mu\text{F}$		19.1		μs	
t_{OFF}	Turn-off time			4.7			
t_R	V_{OUT} rise time			9.0			
t_F	V_{OUT} fall time			2.0			
t_D	Delay time			15.6			
$V_{IN} = 0.8\text{ V}$, $V_{ON} = 5\text{ V}$, $V_{BIAS} = 3.0\text{ V}$, $T_A = 25^\circ\text{C}$ (unless otherwise noted)							
t_{ON}	Turn-on time	$R_L = 10\ \Omega$, $C_L = 0.1\ \mu\text{F}$		19.0		μs	
t_{OFF}	Turn-off time			5.4			
t_R	V_{OUT} rise time			7.0			
t_F	V_{OUT} fall time			1.9			
t_D	Delay time			15.7			

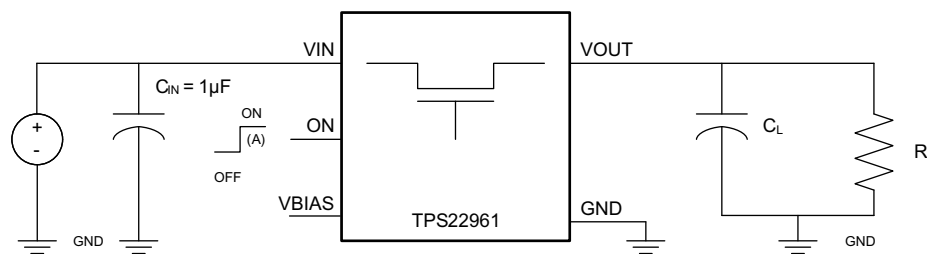

Timing Test Circuit

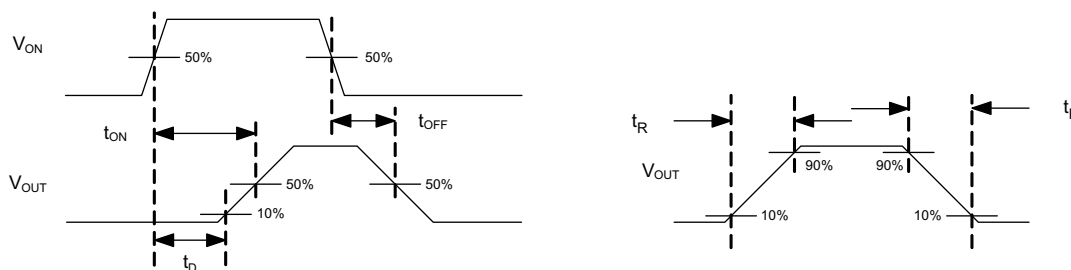

Timing Waveforms

(A) Rise and fall times of the control signal is 100ns.

Figure 1. Switching Characteristics Measurement Setup and Definitions

7.8 Typical Characteristics

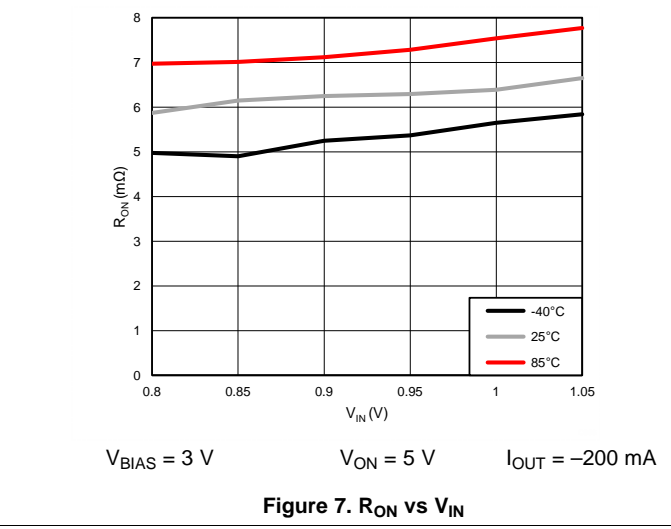
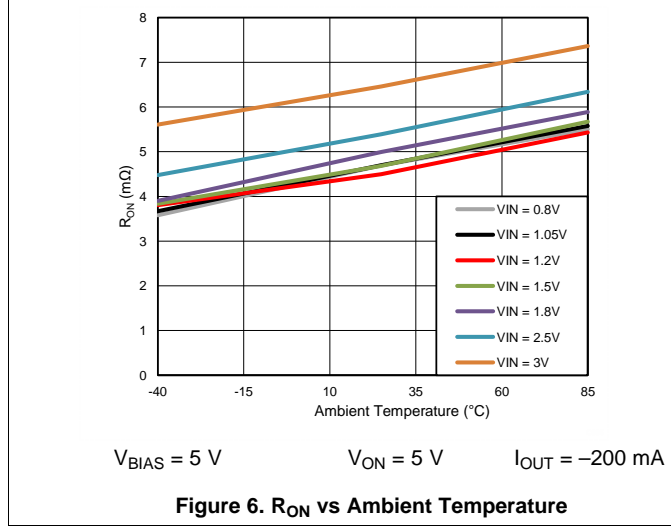
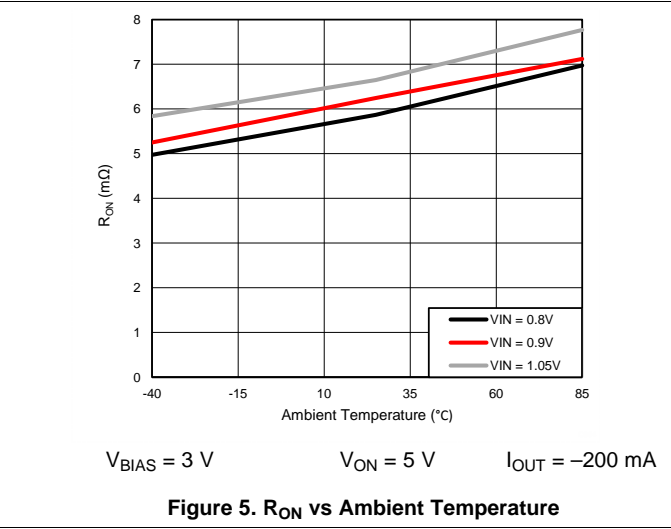
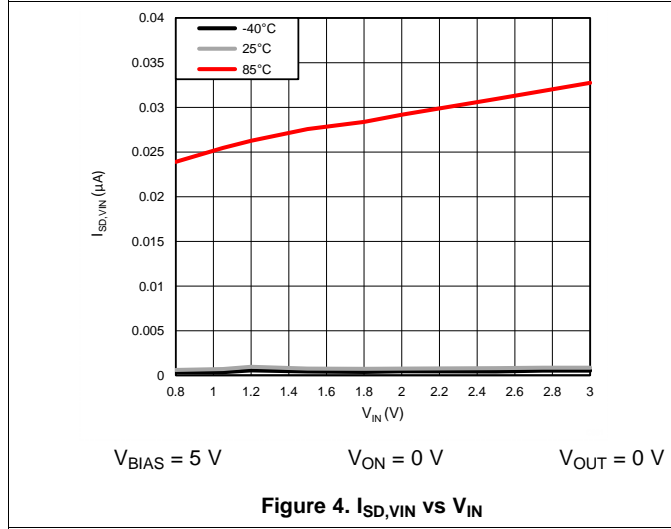
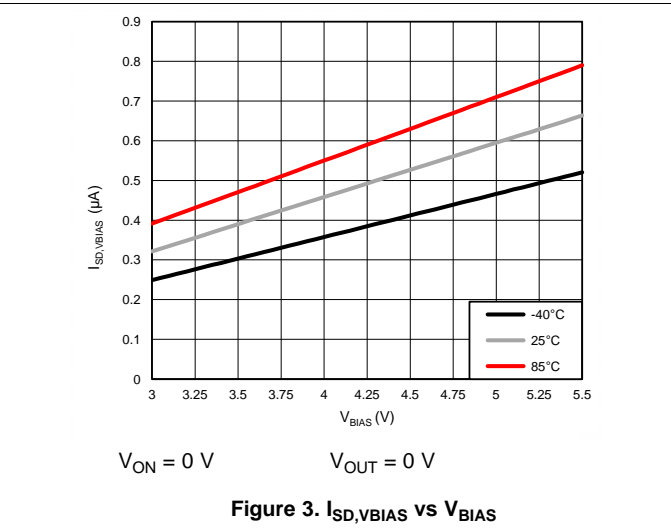
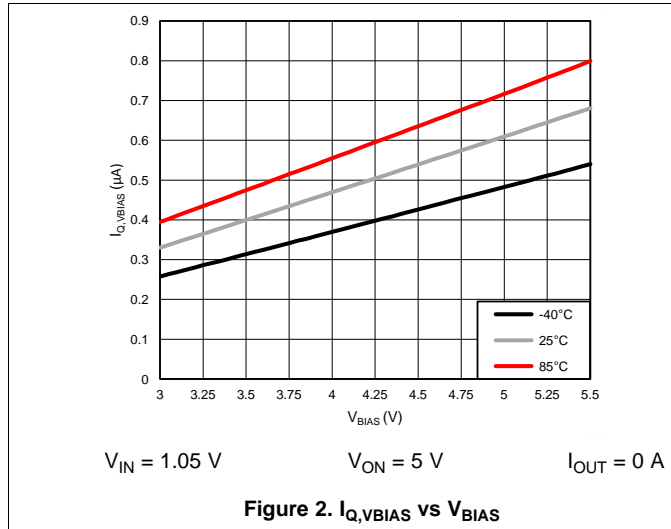

Typical Characteristics (continued)

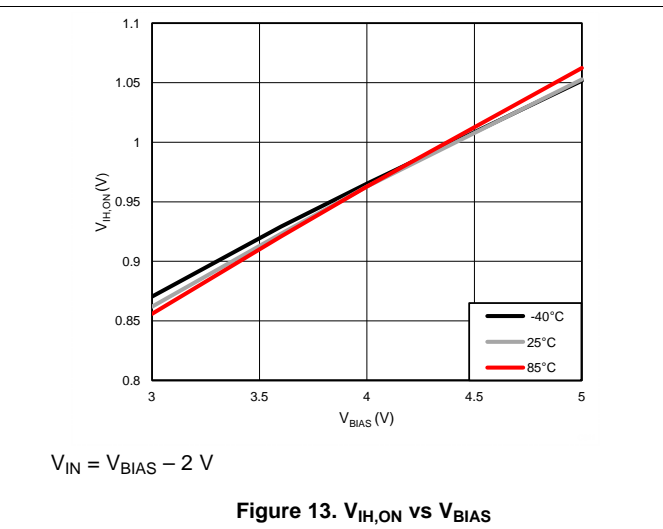
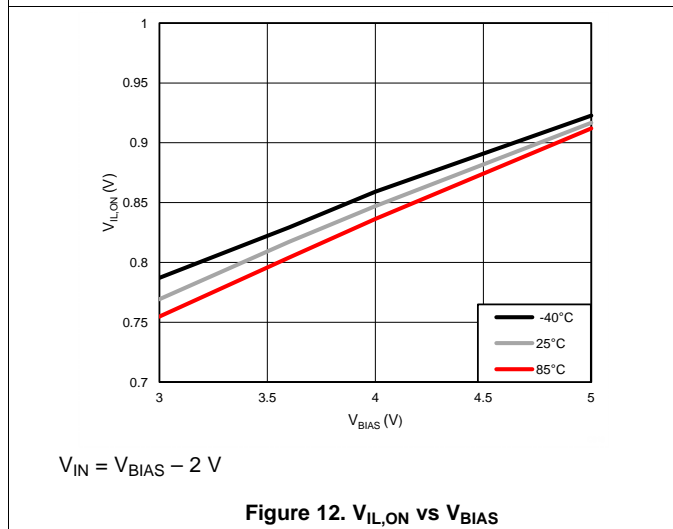
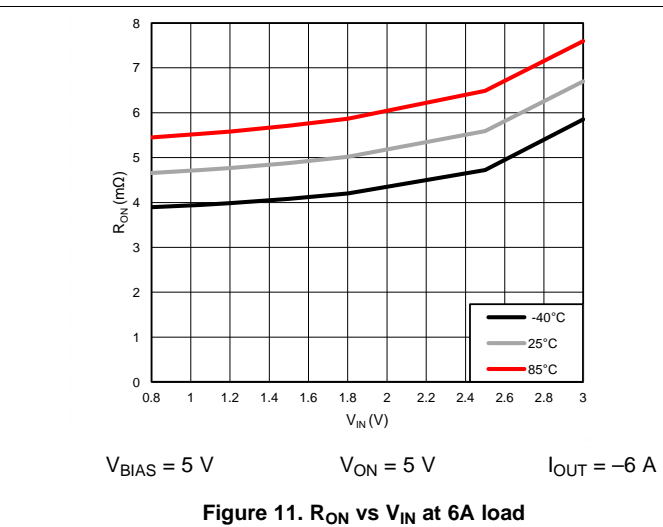
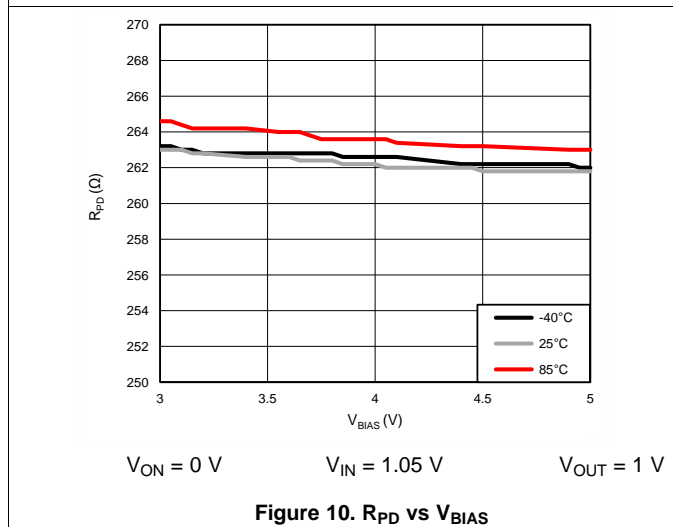
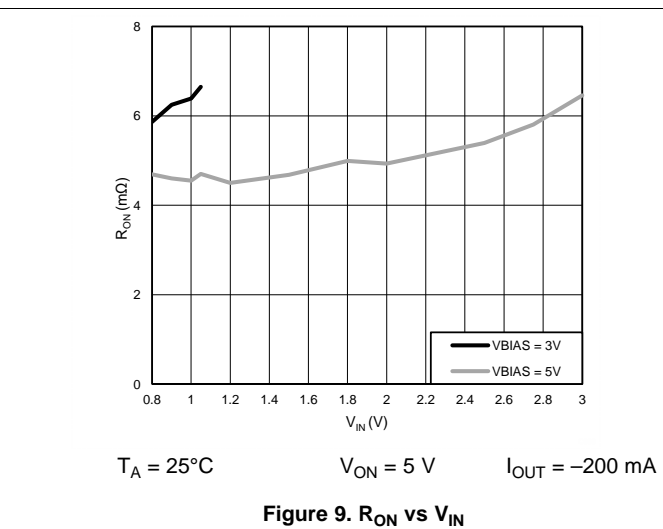
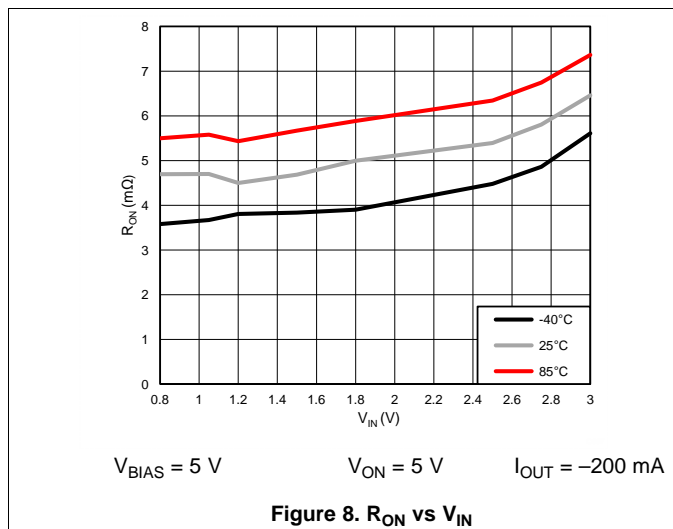

Typical Characteristics (continued)

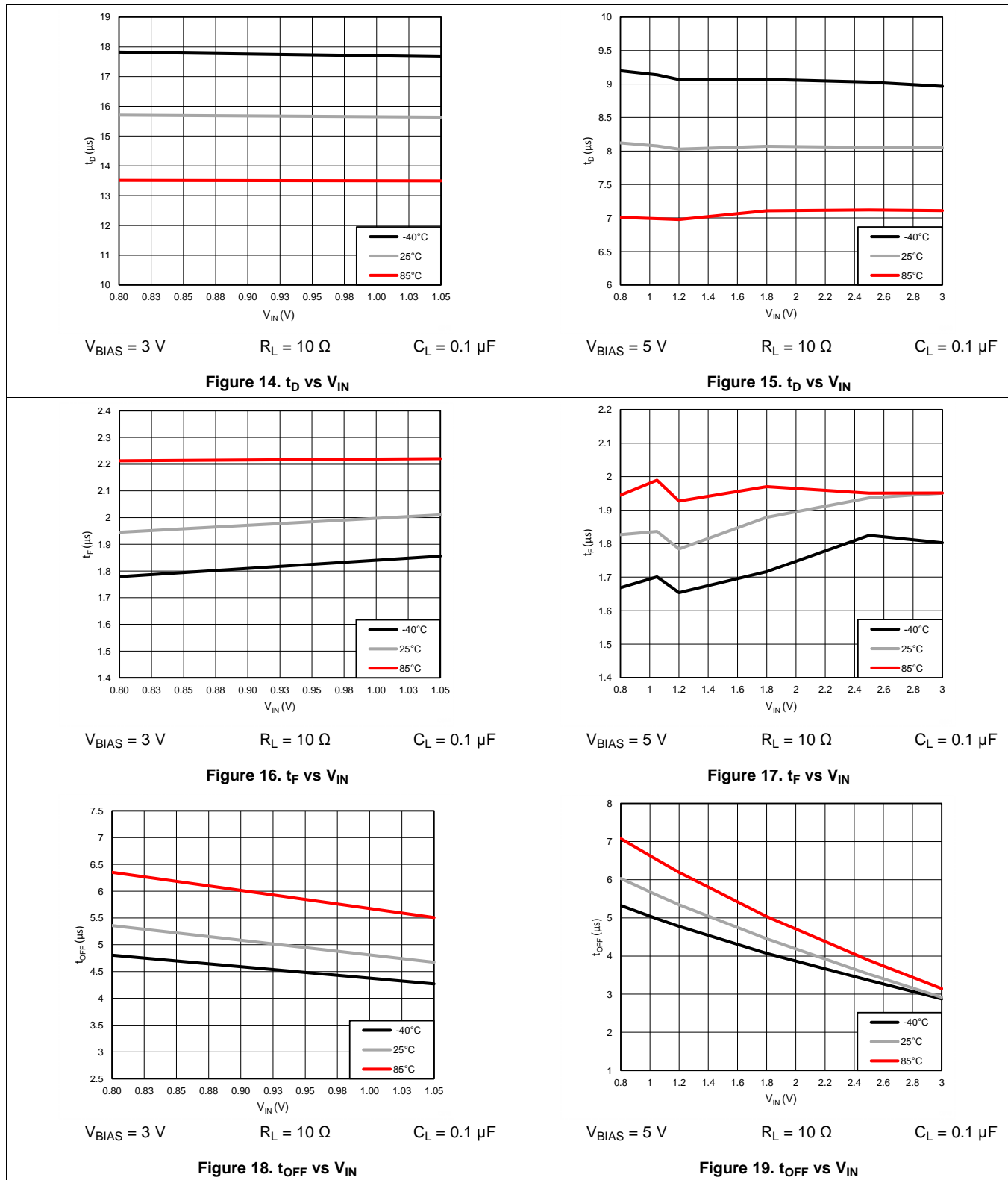

Typical Characteristics (continued)

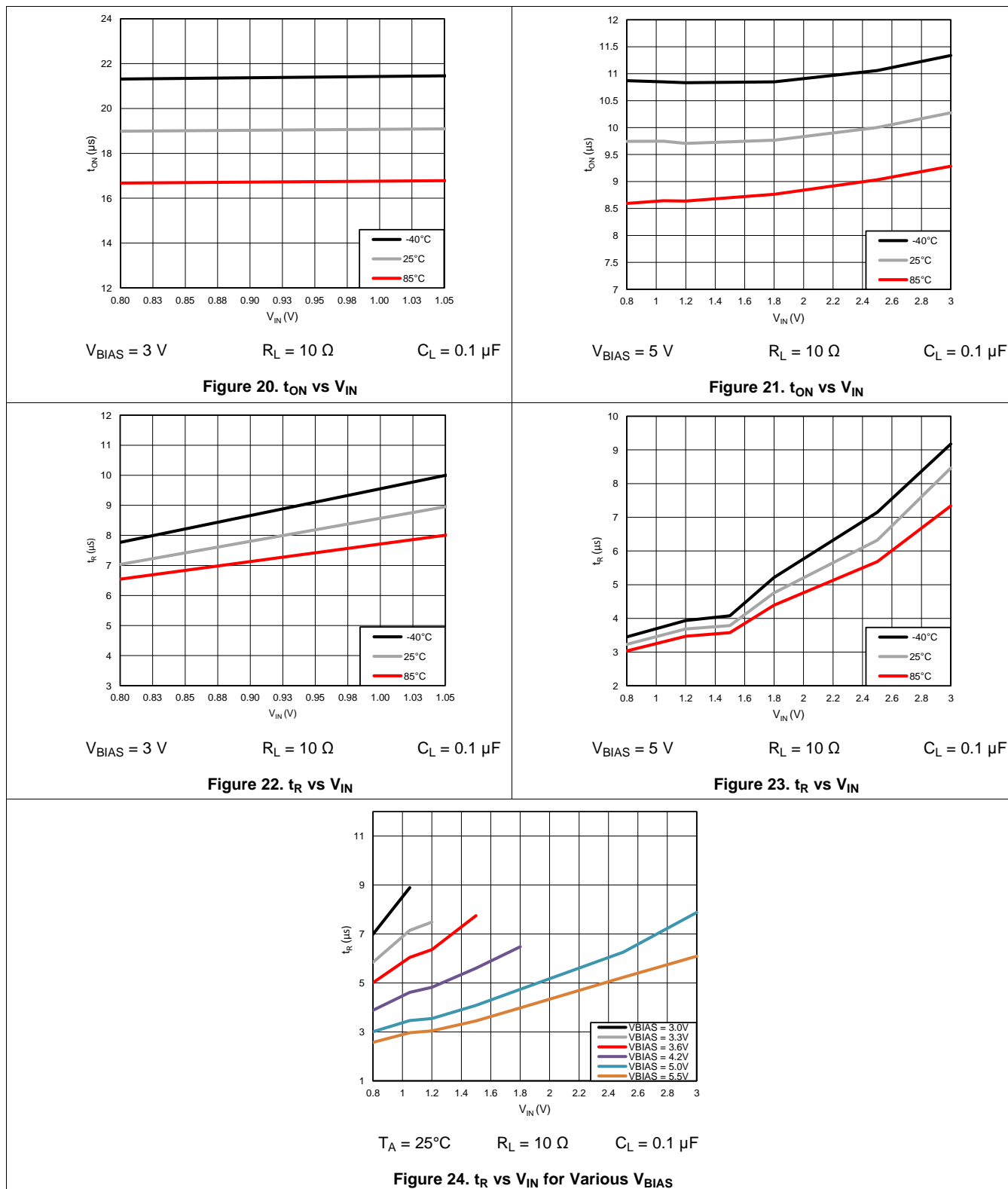

8 Detailed Description

8.1 Overview

The device is a 3.5 V, 6 A load switch in a 8-terminal SON package. To reduce voltage drop for low voltage and high current rails, the device implements an ultra-low resistance N-channel MOSFET which reduces the drop out voltage through the device at very high currents.

The device has a controlled, yet quick, fixed slew rate for applications that require quick turn-on response. During shutdown, the device has very low leakage currents, thereby reducing unnecessary leakages for downstream modules during standby. Integrated control logic, driver, and output discharge FET eliminates the need for any external components, which reduces solution size and BOM count.

8.2 Functional Block Diagram

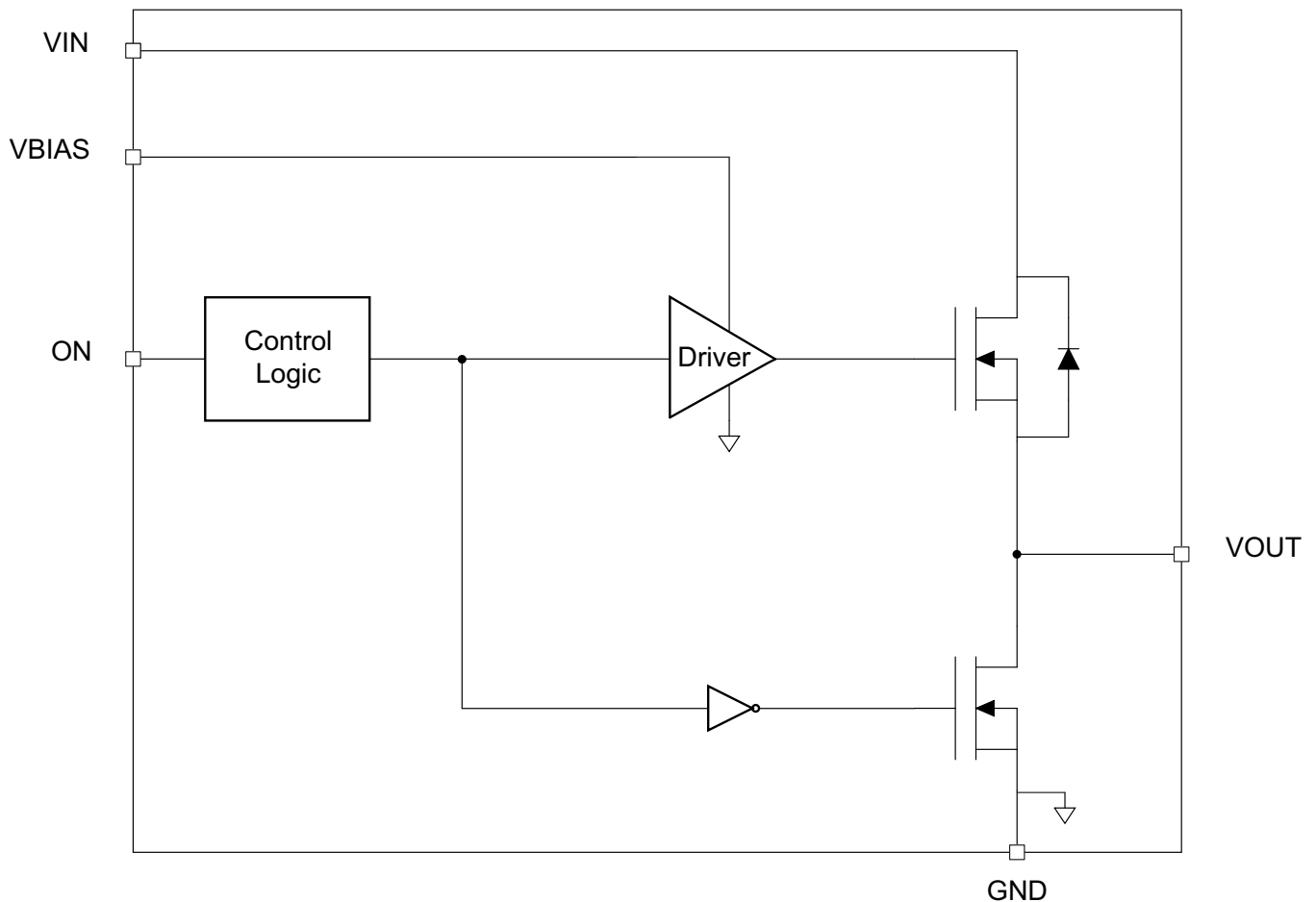

8.3 Feature Description

8.3.1 On/off Control

The ON terminal controls the state of the load switch, and asserting the terminal high (active high) enables the switch. The ON terminal is compatible with standard GPIO logic threshold and can be used with any microcontroller or discrete logic with 1.2 V or higher GPIO voltage. This terminal cannot be left floating and must be tied either high or low for proper functionality.

8.3.2 Input Capacitor (C_{IN})

To limit the voltage drop on the input supply caused by transient in-rush currents when the switch turns on into a discharged load capacitor or short-circuit, a capacitor needs to be placed between V_{IN} and GND. A 1 μ F ceramic capacitor, C_{IN} , placed close to the terminals, is usually sufficient. Higher values of C_{IN} can be used to further reduce the voltage drop in high-current application. When switching heavy loads, it is recommended to have an input capacitor 10 times higher than the output capacitor to avoid excessive voltage drop.

8.3.3 Output Capacitor (C_L)

Due to the integrated body diode in the NMOS switch, a C_{IN} greater than C_L is highly recommended. A C_L greater than C_{IN} can cause V_{OUT} to exceed V_{IN} when the system supply is removed. This could result in current flow through the body diode from V_{OUT} to V_{IN} . A C_{IN} to C_L ratio of 10 to 1 is recommended for minimizing V_{IN} dip caused by inrush currents during startup, however a 10 to 1 ratio for capacitance is not required for proper functionality of the device. A ratio smaller than 10 to 1 (such as 1 to 1) could cause a V_{IN} dip upon turn-on due to inrush currents.

8.3.4 V_{IN} and V_{BIAS} Voltage Range

For optimal R_{ON} performance, make sure $V_{IN} \leq (V_{BIAS} - 1.95 \text{ V})$. For example, in order to have $V_{IN} = 3.5\text{V}$, V_{BIAS} must be 5.5 V. The device will still be functional if $V_{IN} > (V_{BIAS} - 1.95 \text{ V})$ but it will exhibit R_{ON} greater than what is listed in the [Electrical Characteristics, \$V_{BIAS} = 5.0 \text{ V}\$](#) table. See [Figure 25](#) for an example of a typical device. Notice the increasing R_{ON} as V_{IN} increases. Be sure to never exceed the maximum voltage rating for V_{IN} and V_{BIAS} .

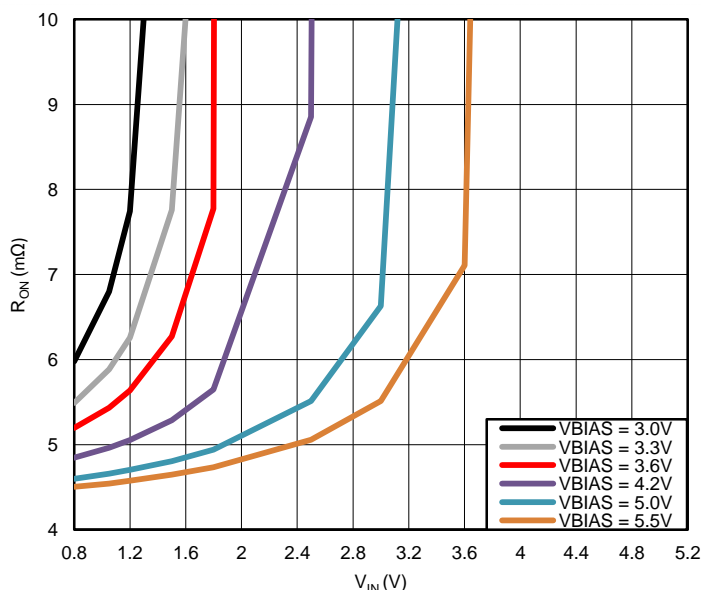

Figure 25. R_{ON} vs V_{IN} ($V_{IN} > V_{BIAS}$)

9 Applications and Implementation

NOTE

Information in the following applications sections is not part of the TI component specification, and TI does not warrant its accuracy or completeness. TI's customers are responsible for determining suitability of components for their purposes. Customers should validate and test their design implementation to confirm system functionality.

9.1 Application Information

This section will highlight some of the design considerations when implementing this device in various applications. A PSPICE model for this device is also available in the product page of this device on www.ti.com for further aid.

9.2 Typical Application

9.2.1 Typical Application Powering a Downstream Module

This application demonstrates how the TPS22961 can be used to power downstream modules.

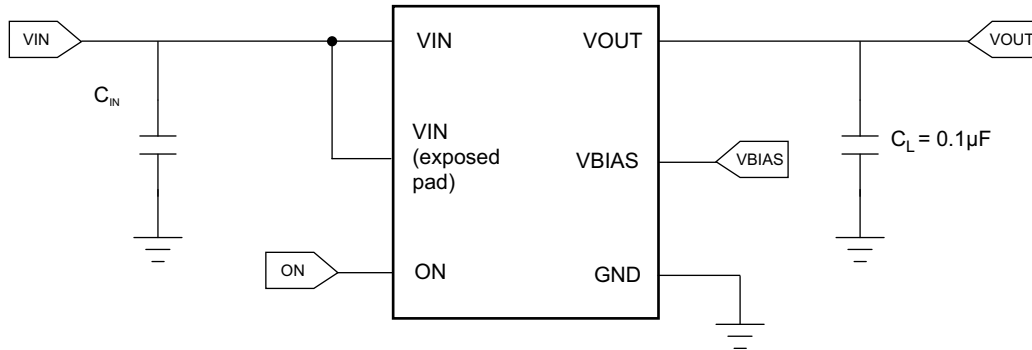

Figure 26. Typical Application Schematic for Powering a Downstream Module

9.2.1.1 Design Requirements

For this design example, use the following as the input parameters.

Table 1. Design Parameters

DESIGN PARAMETER	EXAMPLE VALUE
V_{IN}	1.05 V
V_{BIAS}	5.0 V
Load current	6 A

9.2.1.2 Detailed Design Procedure

To begin the design process, the designer needs to know the following:

- V_{IN} voltage
- V_{BIAS} voltage
- Load current

9.2.1.2.1 VIN to VOUT Voltage Drop

The VIN to VOUT voltage drop in the device is determined by the R_{ON} of the device and the load current. The R_{ON} of the device depends upon the V_{IN} and V_{BIAS} conditions of the device. Refer to the R_{ON} specification of the device in the Electrical Characteristics table of this datasheet. Once the R_{ON} of the device is determined based upon the V_{IN} and V_{BIAS} conditions, use [Equation 1](#) to calculate the VIN to VOUT voltage drop:

$$\Delta V = I_{LOAD} \times R_{ON} \quad (1)$$

where

- ΔV = voltage drop from VIN to VOUT
- I_{LOAD} = load current
- R_{ON} = On-resistance of the device for a specific V_{IN} and V_{BIAS} combination

An appropriate I_{LOAD} must be chosen such that the I_{MAX} specification of the device is not violated.

9.2.1.2.2 Inrush Current

To determine how much inrush current will be caused by the C_L capacitor, use [Equation 2](#):

$$I_{INRUSH} = C_L \times \frac{dV_{OUT}}{dt} \quad (2)$$

where

- I_{INRUSH} = amount of inrush caused by C_L
- C_L = capacitance on VOUT
- dt = time it takes for change in V_{OUT} during the ramp up of VOUT when the device is enabled
- dV_{OUT} = change in V_{OUT} during the ramp up of VOUT when the device is enabled

An appropriate C_L value should be placed on VOUT such that the I_{MAX} and I_{PLS} specifications of the device are not violated.

9.2.1.2.3 Thermal Considerations

The maximum IC junction temperature should be restricted to 125°C under normal operating conditions. To calculate the maximum allowable dissipation, $P_{D(max)}$ for a given output current and ambient temperature, use [Equation 3](#).

$$P_{D(MAX)} = \frac{T_{J(MAX)} - T_A}{R_{\theta JA}} \quad (3)$$

where

- $P_{D(max)}$ = maximum allowable power dissipation
- $T_{J(max)}$ = maximum allowable junction temperature (125°C for the TPS22961)
- T_A = ambient temperature of the device
- Θ_{JA} = junction to air thermal impedance. See [Thermal Information](#) section. This parameter is highly dependent upon board layout.

9.2.1.3 Application Curves

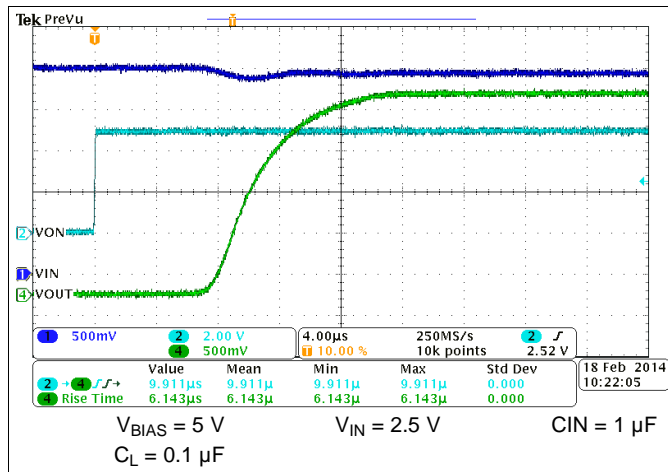

Figure 27. t_R at $V_{BIAS} = 5\text{ V}$

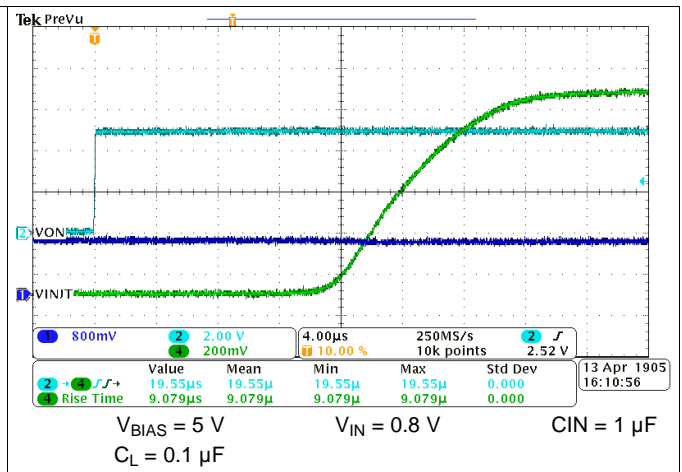

Figure 28. t_R at $V_{BIAS} = 5\text{ V}$

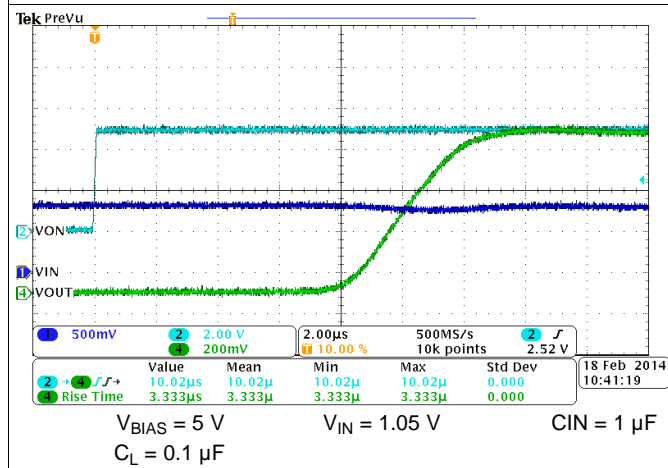

Figure 29. t_R at $V_{BIAS} = 3\text{ V}$

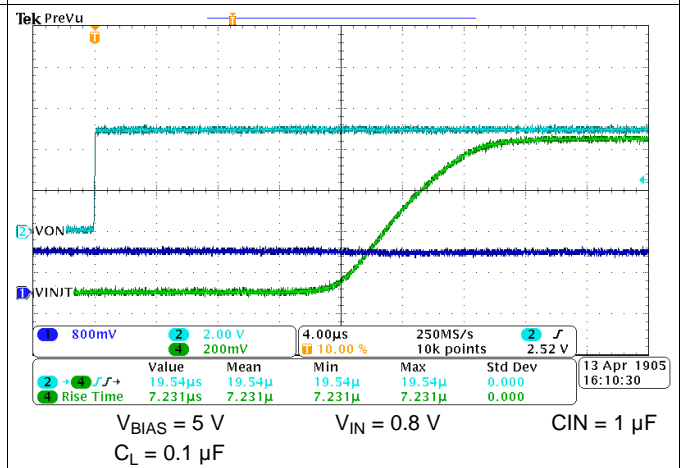

Figure 30. t_R at $V_{BIAS} = 3\text{ V}$

9.2.2 Typical Application Powering Rails Sensitive to Ringing and Overvoltage due to Fast Rise Time

This application demonstrates how the TPS22961 can be used to power rails sensitive to ringing and overvoltage that can often happen due to fast rise times.

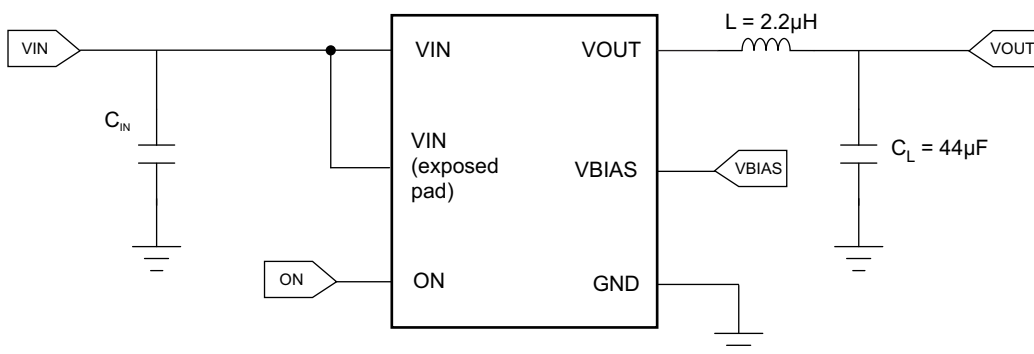

Figure 31. Typical Application Schematic for Powering Rails Sensitive to Ringing

9.2.2.1 Design Requirements

For this design example, use the following as the input parameters.

Table 2. Design Parameters

DESIGN PARAMETER	EXAMPLE VALUE
V_{IN}	1.05 V
V_{BIAS}	5.0 V
Acceptable percent overshoot (ρ)	3.2%
Maximum settling time (t_{SETTLE})	40 μ s

9.2.2.2 Detailed Design Procedure

To begin the design process, the designer needs to know the following:

- V_{IN} voltage
- V_{BIAS} voltage
- Acceptable percent overshoot
- Maximum allowed settling time for the power rail

9.2.2.2.1 Picking Proper Inductor and Capacitor to Meet Voltage Overshoot Requirements

To determine the value of L and C_L in the circuit, the damping factor associated with the acceptable percent overshoot must be calculated. To calculate the damping factor (ϵ), use Equation 4.

$$\epsilon = \frac{-\ln \rho}{\sqrt{\pi^2 + (\ln \rho)^2}} \quad (4)$$

where

- ϵ = damping factor of the LC filter
- ρ = allowable percent overshoot for the power rail

Use the damping factor calculated in Equation 4 to determine the inductance (L), the DCR of the inductor (R_{DCR}), and capacitance (C_L) to achieve the percent overshoot. This will be an iterative process to determine the optimal combination of L and C_L with standard value components available. Use Equation 5 to determine the combination of L, R_{DCR} , and C_L that is needed to satisfy damping factor calculated from Equation 4.

$$\epsilon = \frac{R_{DCR}}{2} \times \sqrt{\frac{C_L}{L}} \tag{5}$$

where

- ϵ = damping factor of the LC filter
- R_{DCR} = DCR of the inductor
- C_L = the capacitance of the filter
- L = the inductor of the filter

To determine the setting time (within 5% of steady state value) of the filter, use Equation 6.

$$t_{SETTLE} \approx \frac{3 \times \sqrt{L \times C_L}}{\epsilon} \tag{6}$$

where

- t_{SETTLE} = settling time of filter to within 5% of steady state value
- ϵ = damping factor of the LC filter
- C_L = the capacitance of the filter
- L = the inductor of the filter

The combination of damping factor (ϵ) and filter settling time (t_{SETTLE}) will bound the values for L, R_{DCR} , and C_L that can be used to meet the design constraints in Table 2.

9.2.2.3 Application Curves

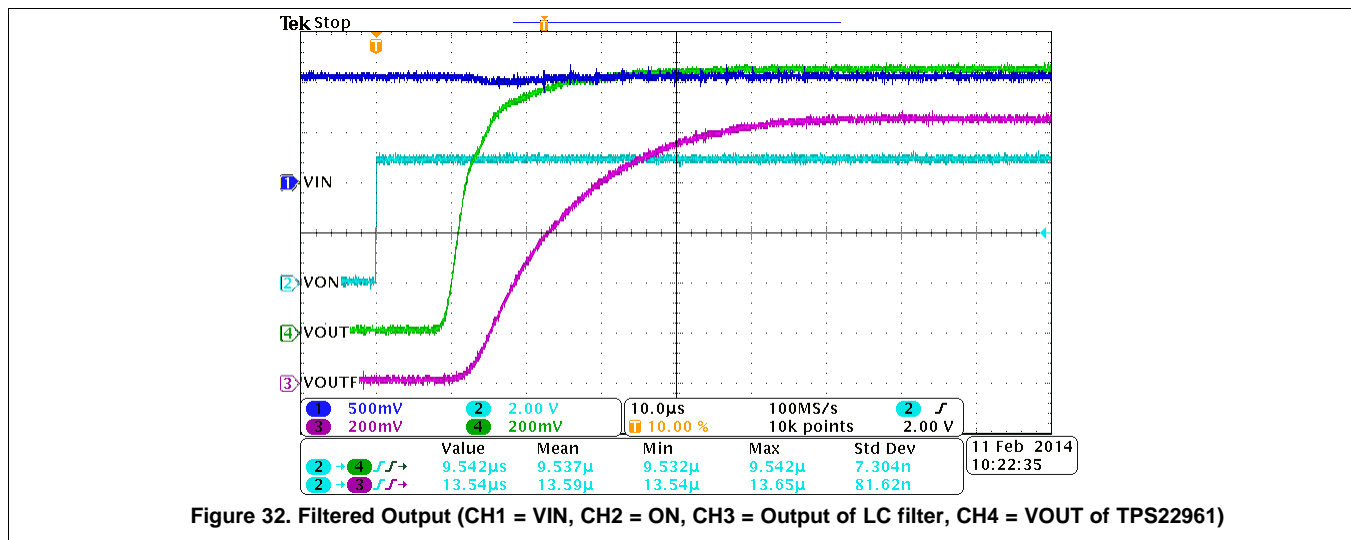

10 Power Supply Recommendations

The device is designed to operate from a V_{BIAS} range of 3 V to 5.5 V and VIN range of 0.8 V to 3.5 V. This supply must be well regulated and placed as close to the TPS22961 as possible. If the supply is located more than a few inches from the device terminals, additional bulk capacitance may be required in addition to the ceramic bypass capacitors. An electrolytic, tantalum, or ceramic capacitor of 10 µF may be sufficient.

11 Layout

11.1 Layout Guidelines

- VIN and VOUT traces should be as short and wide as possible to accommodate for high current.
- Use vias under the exposed thermal pad for thermal relief for high current operation.
- The VIN terminal should be bypassed to ground with low ESR ceramic bypass capacitors. The typical recommended bypass capacitance is 1- μ F ceramic with X5R or X7R dielectric. This capacitor should be placed as close to the device terminals as possible.
- The VOUT terminal should be bypassed to ground with low ESR ceramic bypass capacitors. The typical recommended bypass capacitance is one-tenth of the VIN bypass capacitor of X5R or X7R dielectric rating. This capacitor should be placed as close to the device terminals as possible.
- The VBIAS terminal should be bypassed to ground with low ESR ceramic bypass capacitors. The typical recommended bypass capacitance is 0.1- μ F ceramic with X5R or X7R dielectric.

11.2 Layout Example

○ VIA to Power Ground Plane

⊖ VIA to VIN Plane

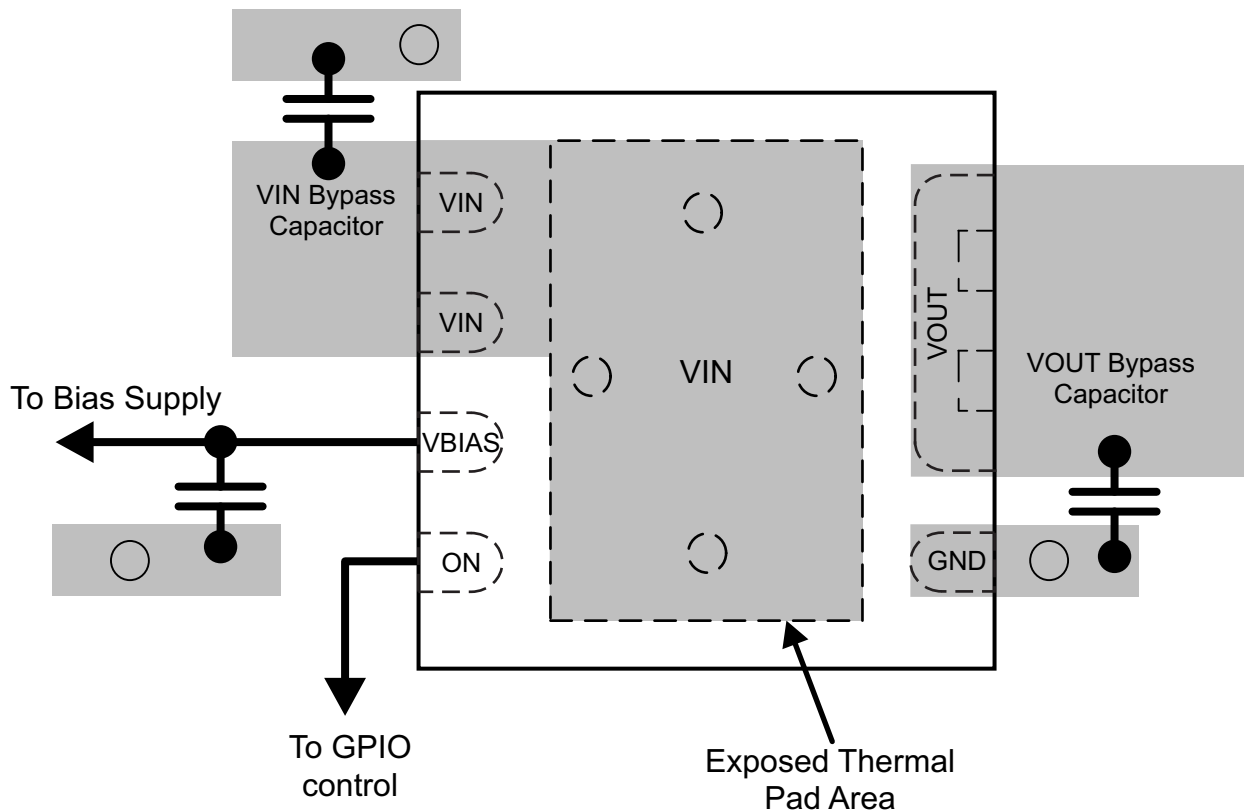

Figure 33. Recommended Board Layout

12 Device and Documentation Support

12.1 Trademarks

Ultrabook is a trademark of Intel.

12.2 Electrostatic Discharge Caution



These devices have limited built-in ESD protection. The leads should be shorted together or the device placed in conductive foam during storage or handling to prevent electrostatic damage to the MOS gates.

12.3 Glossary

[SLYZ022](#) — *TI Glossary*.

This glossary lists and explains terms, acronyms, and definitions.

13 Mechanical, Packaging, and Orderable Information

The following pages include mechanical packaging and orderable information. This information is the most current data available for the designated devices. This data is subject to change without notice and revision of this document. For browser-based versions of this data sheet, refer to the left-hand navigation.

PACKAGING INFORMATION

Orderable Device	Status (1)	Package Type	Package Drawing	Pins	Package Qty	Eco Plan (2)	Lead/Ball Finish (6)	MSL Peak Temp (3)	Op Temp (°C)	Device Marking (4/5)	Samples
TPS22961DNYR	ACTIVE	WSO	DNY	8	3000	Green (RoHS & no Sb/Br)	CU NIPDAU	Level-2-260C-1 YEAR	-40 to 85	961A1	Samples
TPS22961DNYT	ACTIVE	WSO	DNY	8	250	Green (RoHS & no Sb/Br)	CU NIPDAU	Level-2-260C-1 YEAR	-40 to 85	961A1	Samples

(1) The marketing status values are defined as follows:

ACTIVE: Product device recommended for new designs.

LIFEBUY: TI has announced that the device will be discontinued, and a lifetime-buy period is in effect.

NRND: Not recommended for new designs. Device is in production to support existing customers, but TI does not recommend using this part in a new design.

PREVIEW: Device has been announced but is not in production. Samples may or may not be available.

OBSELETE: TI has discontinued the production of the device.

(2) Eco Plan - The planned eco-friendly classification: Pb-Free (RoHS), Pb-Free (RoHS Exempt), or Green (RoHS & no Sb/Br) - please check <http://www.ti.com/productcontent> for the latest availability information and additional product content details.

TBD: The Pb-Free/Green conversion plan has not been defined.

Pb-Free (RoHS): TI's terms "Lead-Free" or "Pb-Free" mean semiconductor products that are compatible with the current RoHS requirements for all 6 substances, including the requirement that lead not exceed 0.1% by weight in homogeneous materials. Where designed to be soldered at high temperatures, TI Pb-Free products are suitable for use in specified lead-free processes.

Pb-Free (RoHS Exempt): This component has a RoHS exemption for either 1) lead-based flip-chip solder bumps used between the die and package, or 2) lead-based die adhesive used between the die and leadframe. The component is otherwise considered Pb-Free (RoHS compatible) as defined above.

Green (RoHS & no Sb/Br): TI defines "Green" to mean Pb-Free (RoHS compatible), and free of Bromine (Br) and Antimony (Sb) based flame retardants (Br or Sb do not exceed 0.1% by weight in homogeneous material)

(3) MSL, Peak Temp. - The Moisture Sensitivity Level rating according to the JEDEC industry standard classifications, and peak solder temperature.

(4) There may be additional marking, which relates to the logo, the lot trace code information, or the environmental category on the device.

(5) Multiple Device Markings will be inside parentheses. Only one Device Marking contained in parentheses and separated by a "~" will appear on a device. If a line is indented then it is a continuation of the previous line and the two combined represent the entire Device Marking for that device.

(6) Lead/Ball Finish - Orderable Devices may have multiple material finish options. Finish options are separated by a vertical ruled line. Lead/Ball Finish values may wrap to two lines if the finish value exceeds the maximum column width.

Important Information and Disclaimer:The information provided on this page represents TI's knowledge and belief as of the date that it is provided. TI bases its knowledge and belief on information provided by third parties, and makes no representation or warranty as to the accuracy of such information. Efforts are underway to better integrate information from third parties. TI has taken and continues to take reasonable steps to provide representative and accurate information but may not have conducted destructive testing or chemical analysis on incoming materials and chemicals. TI and TI suppliers consider certain information to be proprietary, and thus CAS numbers and other limited information may not be available for release.

In no event shall TI's liability arising out of such information exceed the total purchase price of the TI part(s) at issue in this document sold by TI to Customer on an annual basis.

TAPE AND REEL INFORMATION



QUADRANT ASSIGNMENTS FOR PIN 1 ORIENTATION IN TAPE



*All dimensions are nominal

Device	Package Type	Package Drawing	Pins	SPQ	Reel Diameter (mm)	Reel Width W1 (mm)	A0 (mm)	B0 (mm)	K0 (mm)	P1 (mm)	W (mm)	Pin1 Quadrant
TPS22961DNYR	WSON	DNY	8	3000	330.0	12.4	3.3	3.3	1.0	8.0	12.0	Q2
TPS22961DNYT	WSON	DNY	8	250	180.0	12.4	3.3	3.3	1.0	8.0	12.0	Q2

TAPE AND REEL BOX DIMENSIONS

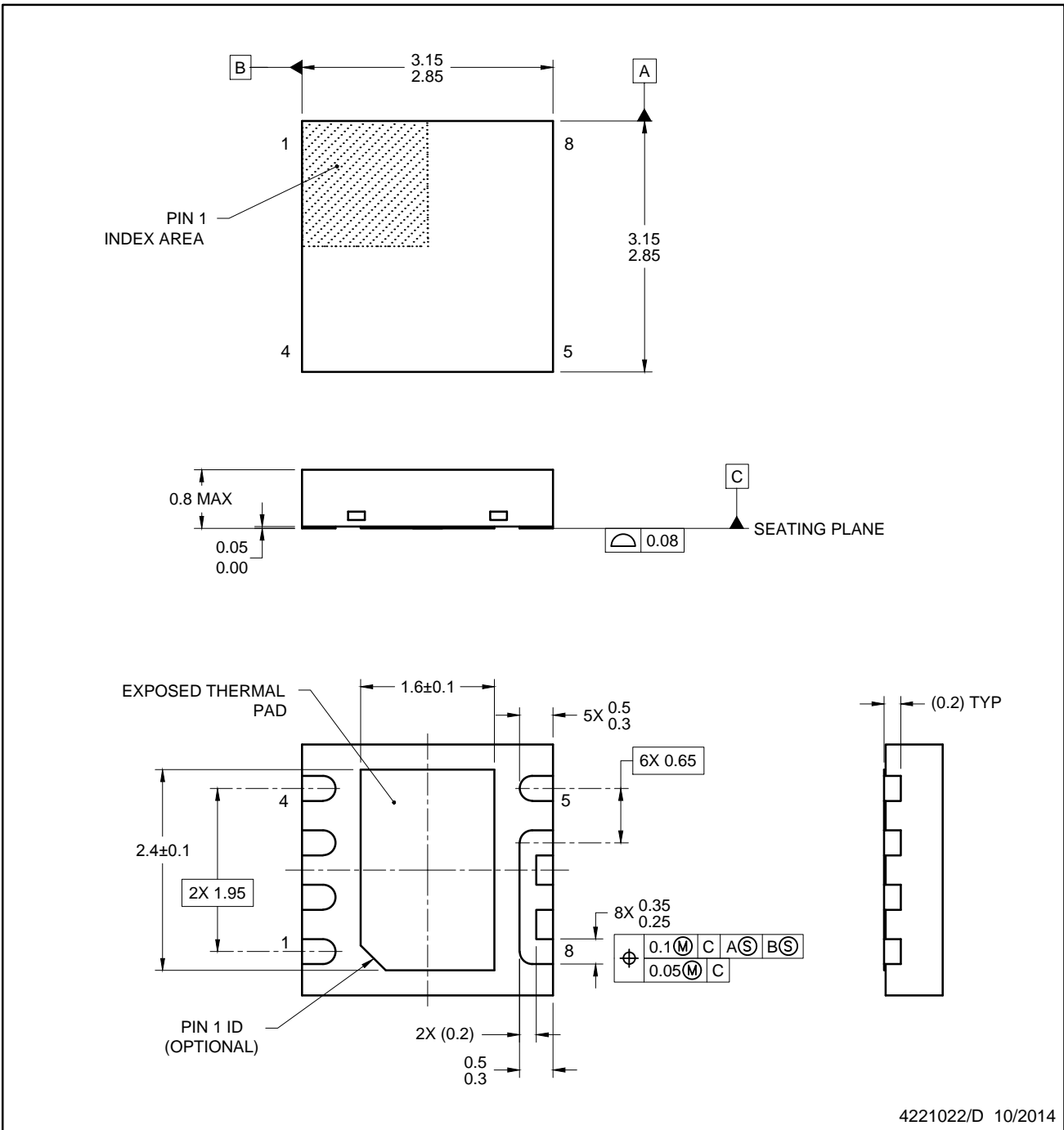

*All dimensions are nominal

Device	Package Type	Package Drawing	Pins	SPQ	Length (mm)	Width (mm)	Height (mm)
TPS22961DNYR	WSON	DNY	8	3000	370.0	355.0	55.0
TPS22961DNYT	WSON	DNY	8	250	195.0	200.0	45.0

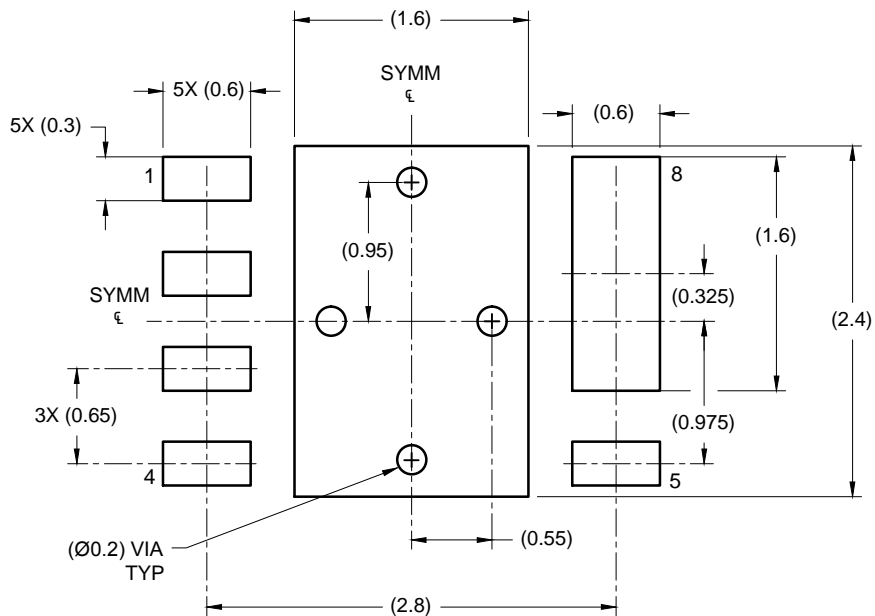

NOTES:

1. All linear dimensions are in millimeters. Any dimensions in parenthesis are for reference only. Dimensioning and tolerancing per ASME Y14.5M.
2. This drawing is subject to change without notice.
3. The package thermal pad must be soldered to the printed circuit board for thermal and mechanical performance.



LAND PATTERN EXAMPLE
SCALE: 20X

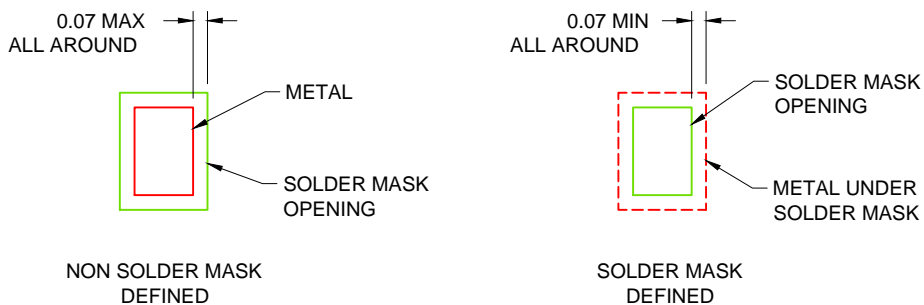

SOLDER MASK DETAILS

4221022/D 10/2014

NOTES: (continued)

4. This package is designed to be soldered to a thermal pad on the board. For more information, see Texas Instruments literature number SLUA271 (www.ti.com/lit/sluea271).
5. Solder mask tolerances between and around signal pads can vary based on board fabrication site.

EXAMPLE STENCIL DESIGN

DNY0008A

WSON - 0.8 mm max height

PLASTIC SMALL OUTLINE - NO LEAD

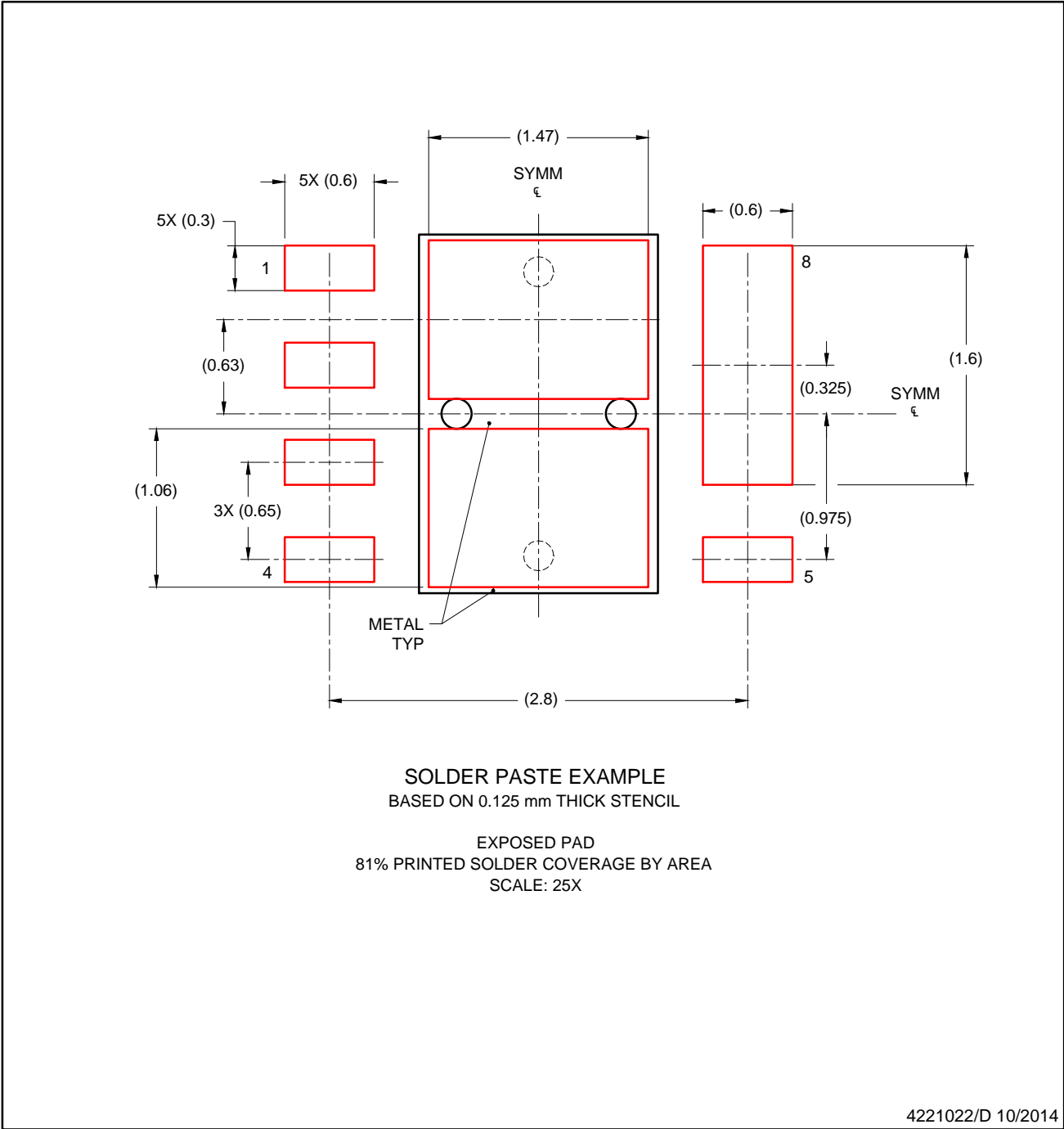

NOTES: (continued)

- 6. Laser cutting apertures with trapezoidal walls and rounded corners may offer better paste release. IPC-7525 may have alternate design recommendations.

IMPORTANT NOTICE

Texas Instruments Incorporated (TI) reserves the right to make corrections, enhancements, improvements and other changes to its semiconductor products and services per JESD46, latest issue, and to discontinue any product or service per JESD48, latest issue. Buyers should obtain the latest relevant information before placing orders and should verify that such information is current and complete.

TI's published terms of sale for semiconductor products (<http://www.ti.com/sc/docs/stdterms.htm>) apply to the sale of packaged integrated circuit products that TI has qualified and released to market. Additional terms may apply to the use or sale of other types of TI products and services.

Reproduction of significant portions of TI information in TI data sheets is permissible only if reproduction is without alteration and is accompanied by all associated warranties, conditions, limitations, and notices. TI is not responsible or liable for such reproduced documentation. Information of third parties may be subject to additional restrictions. Resale of TI products or services with statements different from or beyond the parameters stated by TI for that product or service voids all express and any implied warranties for the associated TI product or service and is an unfair and deceptive business practice. TI is not responsible or liable for any such statements.

Buyers and others who are developing systems that incorporate TI products (collectively, "Designers") understand and agree that Designers remain responsible for using their independent analysis, evaluation and judgment in designing their applications and that Designers have full and exclusive responsibility to assure the safety of Designers' applications and compliance of their applications (and of all TI products used in or for Designers' applications) with all applicable regulations, laws and other applicable requirements. Designer represents that, with respect to their applications, Designer has all the necessary expertise to create and implement safeguards that (1) anticipate dangerous consequences of failures, (2) monitor failures and their consequences, and (3) lessen the likelihood of failures that might cause harm and take appropriate actions. Designer agrees that prior to using or distributing any applications that include TI products, Designer will thoroughly test such applications and the functionality of such TI products as used in such applications.

TI's provision of technical, application or other design advice, quality characterization, reliability data or other services or information, including, but not limited to, reference designs and materials relating to evaluation modules, (collectively, "TI Resources") are intended to assist designers who are developing applications that incorporate TI products; by downloading, accessing or using TI Resources in any way, Designer (individually or, if Designer is acting on behalf of a company, Designer's company) agrees to use any particular TI Resource solely for this purpose and subject to the terms of this Notice.

TI's provision of TI Resources does not expand or otherwise alter TI's applicable published warranties or warranty disclaimers for TI products, and no additional obligations or liabilities arise from TI providing such TI Resources. TI reserves the right to make corrections, enhancements, improvements and other changes to its TI Resources. TI has not conducted any testing other than that specifically described in the published documentation for a particular TI Resource.

Designer is authorized to use, copy and modify any individual TI Resource only in connection with the development of applications that include the TI product(s) identified in such TI Resource. NO OTHER LICENSE, EXPRESS OR IMPLIED, BY ESTOPPEL OR OTHERWISE TO ANY OTHER TI INTELLECTUAL PROPERTY RIGHT, AND NO LICENSE TO ANY TECHNOLOGY OR INTELLECTUAL PROPERTY RIGHT OF TI OR ANY THIRD PARTY IS GRANTED HEREIN, including but not limited to any patent right, copyright, mask work right, or other intellectual property right relating to any combination, machine, or process in which TI products or services are used. Information regarding or referencing third-party products or services does not constitute a license to use such products or services, or a warranty or endorsement thereof. Use of TI Resources may require a license from a third party under the patents or other intellectual property of the third party, or a license from TI under the patents or other intellectual property of TI.

TI RESOURCES ARE PROVIDED "AS IS" AND WITH ALL FAULTS. TI DISCLAIMS ALL OTHER WARRANTIES OR REPRESENTATIONS, EXPRESS OR IMPLIED, REGARDING RESOURCES OR USE THEREOF, INCLUDING BUT NOT LIMITED TO ACCURACY OR COMPLETENESS, TITLE, ANY EPIDEMIC FAILURE WARRANTY AND ANY IMPLIED WARRANTIES OF MERCHANTABILITY, FITNESS FOR A PARTICULAR PURPOSE, AND NON-INFRINGEMENT OF ANY THIRD PARTY INTELLECTUAL PROPERTY RIGHTS. TI SHALL NOT BE LIABLE FOR AND SHALL NOT DEFEND OR INDEMNIFY DESIGNER AGAINST ANY CLAIM, INCLUDING BUT NOT LIMITED TO ANY INFRINGEMENT CLAIM THAT RELATES TO OR IS BASED ON ANY COMBINATION OF PRODUCTS EVEN IF DESCRIBED IN TI RESOURCES OR OTHERWISE. IN NO EVENT SHALL TI BE LIABLE FOR ANY ACTUAL, DIRECT, SPECIAL, COLLATERAL, INDIRECT, PUNITIVE, INCIDENTAL, CONSEQUENTIAL OR EXEMPLARY DAMAGES IN CONNECTION WITH OR ARISING OUT OF TI RESOURCES OR USE THEREOF, AND REGARDLESS OF WHETHER TI HAS BEEN ADVISED OF THE POSSIBILITY OF SUCH DAMAGES.

Unless TI has explicitly designated an individual product as meeting the requirements of a particular industry standard (e.g., ISO/TS 16949 and ISO 26262), TI is not responsible for any failure to meet such industry standard requirements.

Where TI specifically promotes products as facilitating functional safety or as compliant with industry functional safety standards, such products are intended to help enable customers to design and create their own applications that meet applicable functional safety standards and requirements. Using products in an application does not by itself establish any safety features in the application. Designers must ensure compliance with safety-related requirements and standards applicable to their applications. Designer may not use any TI products in life-critical medical equipment unless authorized officers of the parties have executed a special contract specifically governing such use. Life-critical medical equipment is medical equipment where failure of such equipment would cause serious bodily injury or death (e.g., life support, pacemakers, defibrillators, heart pumps, neurostimulators, and implantables). Such equipment includes, without limitation, all medical devices identified by the U.S. Food and Drug Administration as Class III devices and equivalent classifications outside the U.S.

TI may expressly designate certain products as completing a particular qualification (e.g., Q100, Military Grade, or Enhanced Product). Designers agree that it has the necessary expertise to select the product with the appropriate qualification designation for their applications and that proper product selection is at Designers' own risk. Designers are solely responsible for compliance with all legal and regulatory requirements in connection with such selection.

Designer will fully indemnify TI and its representatives against any damages, costs, losses, and/or liabilities arising out of Designer's non-compliance with the terms and provisions of this Notice.

Looking for pricing, stock, or lifecycle information?

Click below to explore more details on WIN SOURCE:

 [View TPS22961DNYT on WIN SOURCE](#)

 [Texas Instruments](#) Information

Optimize Your Supply Chain with WIN SOURCE Solutions

-  Global Sourcing Solution
-  Obsolete Management
-  Cost Control Management
-  Shortage Management
-  Alternative Solution
-  Excess Inventory Management