



THE DATASHEET OF TMP125AIDBVTG4



ABSOLUTE MAXIMUM RATINGS(1)

Supply Voltage	+7V
Input Voltage(2)	-0.3V to +7V
Input Current	±10mA
Output Short Circuit(3)	Continuous
Operating Temperature Range	-55°C to +125°C
Storage Temperature Range	-60°C to +150°C
Junction Temperature (T _J max)	+150°C
Lead Temperature (soldering)	+300°C
ESD Rating (Human Body Model)	4000V
(Charged Device Model)	1000V



This integrated circuit can be damaged by ESD. Texas Instruments recommends that all integrated circuits be handled with appropriate precautions. Failure to observe proper handling and installation procedures can cause damage.

ESD damage can range from subtle performance degradation to complete device failure. Precision integrated circuits may be more susceptible to damage because very small parametric changes could cause the device not to meet its published specifications.

- (1) Stresses above these ratings may cause permanent damage. Exposure to absolute maximum conditions for extended periods may degrade device reliability. These are stress ratings only, and functional operation of the device at these or any other conditions beyond those specified is not supported.
- (2) Input terminals are diode-clamped to the power-supply rails. Input signals that can swing more than 0.5V beyond the supply rails should be current limited to 10mA or less.
- (3) Short-circuit to ground.

ORDERING INFORMATION(1)

PRODUCT	PACKAGE-LEAD	PACKAGE DESIGNATOR	PACKAGE MARKING
TMP125	SOT23-6	DBV	T125

(1) For the most current package and ordering information, see the Package Option Addendum at the end of this document, or see the TI web site at www.ti.com.

PIN CONFIGURATION

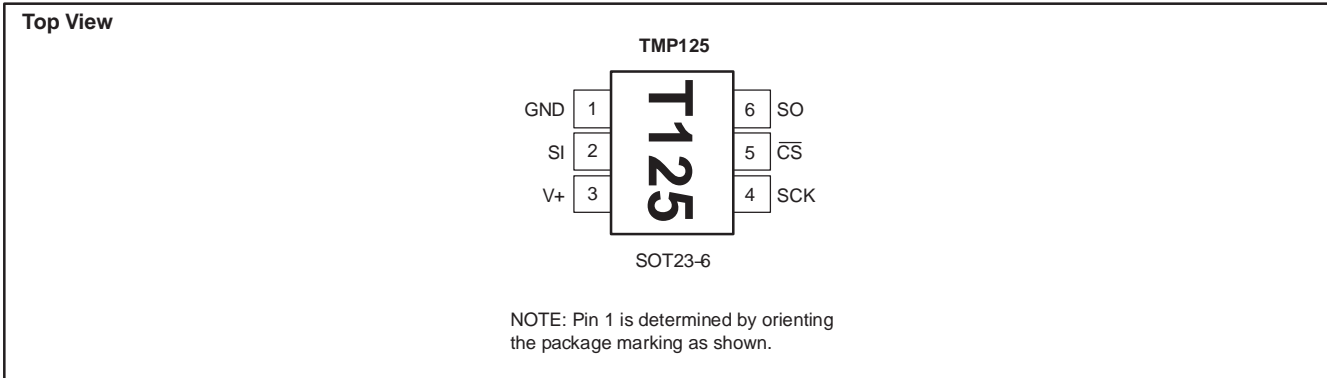

ELECTRICAL CHARACTERISTICS

 At $T_A = -40^\circ\text{C}$ to $+125^\circ\text{C}$ and $V_S = +2.7\text{V}$ to 5.5V , unless otherwise noted.

PARAMETER	CONDITIONS	TMP125			UNIT
		MIN	TYP	MAX	
TEMPERATURE INPUT					
Range		-40		+125	$^\circ\text{C}$
Accuracy (temperature error)	-25 $^\circ\text{C}$ to +85 $^\circ\text{C}$		± 0.5	± 2.0	$^\circ\text{C}$
	-40 $^\circ\text{C}$ to +125 $^\circ\text{C}$		± 1.0	± 2.5	$^\circ\text{C}$
Resolution			10		Bits
Temperature Measurement Noise			0.1		LSB
DIGITAL INPUT/OUTPUT					
Input Logic Levels:					
V_{IH}		0.7(V+)			V
V_{IL}				0.3(V+)	V
Input Current, SI, SCK, $\overline{\text{CS}}$	I_{IN} 0V = $V_{IN} = V+$			± 1	μA
Output Logic Levels:					
$V_{OL\ SO}$	$I_{SINK} = 3\text{mA}$			0.4	V
$V_{OH\ SO}$	$I_{SOURCE} = 2\text{mA}$	(V+)-0.4			V
Input Capacitance, SI, SCK, $\overline{\text{CS}}$			2.5		pF
Conversion Time	10-Bit		60		ms
Update Rate			120		ms
POWER SUPPLY					
Operating Range		2.7		5.5	V
Quiescent Current, at $T_A = 25^\circ\text{C}$	I_Q Serial Bus Inactive		36	50	μA
over Temperature	-40 $^\circ\text{C}$ to +125 $^\circ\text{C}$			60	μA
Shutdown Current			0.1	1	μA
over Temperature				1	μA
TEMPERATURE RANGE					
Specified Range		-40		+125	$^\circ\text{C}$
Operating Range		-55		+125	$^\circ\text{C}$
Storage Range		-60		+150	$^\circ\text{C}$
Thermal Resistance	θ_{JA} SOT23-6 Surface-Mount		200		$^\circ\text{C}/\text{W}$

TYPICAL CHARACTERISTICS

At $T_A = -40^\circ\text{C}$ to $+125^\circ\text{C}$ and $V_S = +2.7\text{V}$ to 5.5V , unless otherwise noted.

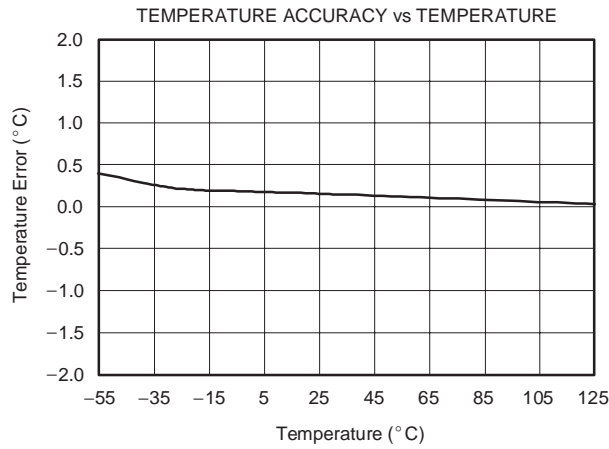
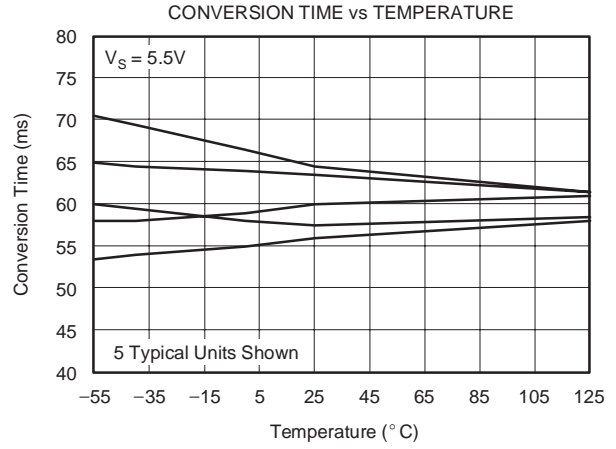
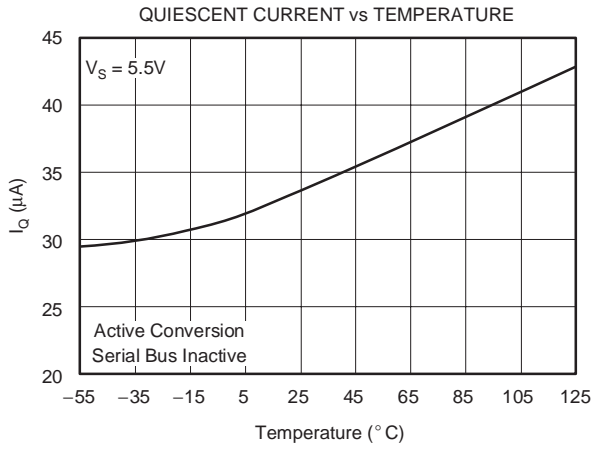

APPLICATIONS

The TMP125 10-bit, read-only digital temperature sensor is optimal for thermal management and thermal protection applications. The TMP125 is specified for a temperature range of -40°C to $+125^{\circ}\text{C}$, with operation extending down to -55°C . It is specified for a supply voltage range of 2.7V to 5.5V, and also features a hardware shutdown to provide power savings. Quiescent current is reduced to $1\mu\text{A}$ during analog shutdown.

The TMP125 communicates through a serial interface that is SPI-compatible. Temperature is converted to a 10-bit data word with 0.25°C resolution. The TMP125 is optimal for low-power applications, with a 120ms conversion period for reduced power consumption.

The sensing device of the TMP125 is the chip itself. Thermal paths run through the package leads as well as the plastic package, and the lower thermal resistance of metal causes the leads to provide the primary thermal path.

The TMP125 requires no external components for operation, though a $0.1\mu\text{F}$ supply bypass capacitor is recommended. Figure 1 shows typical connection for the TMP125.

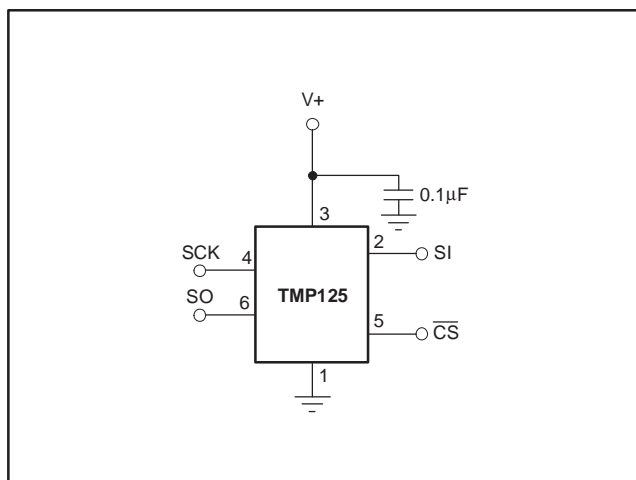

Figure 1. Typical Connections for the TMP125

COMMUNICATING WITH THE TMP125

The TMP125 continuously converts temperatures to digital data. Temperature data is read by pulling $\overline{\text{CS}}$ low. Once $\overline{\text{CS}}$ is pulled low, temperature data from the last completed conversion prior to dropping $\overline{\text{CS}}$ is latched into the shift register and clocked out at SO on the falling SCK edge. The 16-bit data word is clocked out sign bit first, followed by the MSB. The SI pin is used to put the device into shutdown mode. To enter shutdown mode, SI must be high on the rising edge of the third bit of SCK (see Figure 3). Also, all 16 bits must be clocked to allow shutdown on the TMP125. To bring the device out of

shutdown, perform a 16-clock communication with SI set to logic low. The 16-clock communication is the same as the Data Read shown in Figure 3, except that the data on SO will be the last conversion prior to putting the device into shutdown mode. Note that SO is only used to control the shutdown function; if not using this function, connect this pin to ground.

The one-shot command can be used to force a single conversion. When the command is issued, the part will perform a single conversion and then go into shutdown mode. After the conversion is complete, the conversion result should be read with the power-down bit high (see Figure 3) if you do not want to start a new conversion.

The TMP125 will go into idle mode for 60ms, requiring only $20\mu\text{A}$ of current. A new conversion begins every 120ms. Figure 2 describes the conversion timing for the TMP125.

TEMPERATURE REGISTER

The Temperature Register of the TMP125 is a 16-bit, read-only register that stores the output of the most recent conversion. However, temperature is represented by only 10-bits, which are in signed two's complement format. The first bit of the Temperature Register, D15, is a leading zero. Bits D14 and D5 are used to indicate temperature. Bits D4 to D0 are the same as D5 (see Table 1). Data format for temperature is summarized in Table 2. When calculating the signed two's complement temperature value, be sure to use only the 10 data bits.

Following power-up or reset, the Temperature Register will read 0°C until the first conversion is complete.

D15	D14	D13	D12	D11	D10	D9	D8
0	T9	T8	T7	T6	T5	T4	T3
D7	D6	D5	D4	D3	D2	D1	D0
T2	T1	T0	T0	T0	T0	T0	T0

Table 1. Temperature Register

TEMPERATURE ($^{\circ}\text{C}$)	DIGITAL OUTPUT D14...D5
+127	01 1111 1100
+125	01 1111 0100
+100	01 1001 0000
+75	01 0010 1100
+50	00 1100 1000
+25	00 0110 0100
+10	00 0010 1000
+0.25	00 0000 0001
0	00 0000 0000
-0.25	11 1111 1111
-25	11 1001 1100
-50	11 0011 1000
-55	11 0010 0100

Table 2. Temperature Data Format

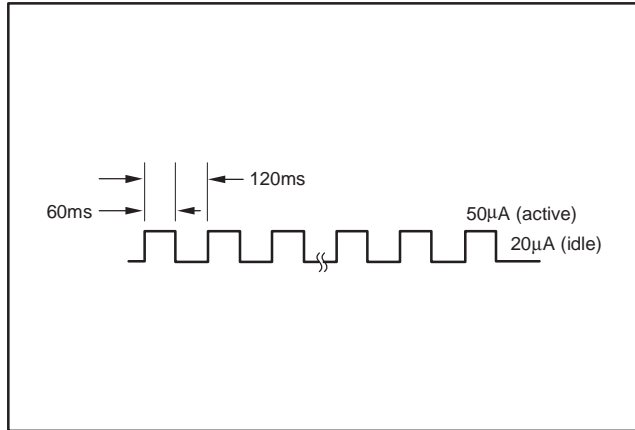

Figure 2. Conversion Time and Period

Timing Diagrams

The TMP125 is SPI-compatible. Figure 3 and Figure 4 describe the output data of the TMP125. Figure 5, Figure 6, and Figure 7 describe the various timing requirements, with parameters defined in Table 3.

PARAMETER	MIN	MAX	UNITS
SCK Period	t_1	100	ns
Data In to Rising Edge SCK Setup Time	t_2	20	ns
SCK Falling Edge to Output Data Delay	t_3	30	ns
SCK Rising Edge to Input Data Hold Time	t_4	20	ns
\overline{CS} to Rising Edge SCK Set-Up Time	t_5	40	ns
\overline{CS} to Output Data Delay	t_6	30	ns
\overline{CS} Rising Edge to Output High Impedance	t_7	30	ns

Table 3. Timing Description

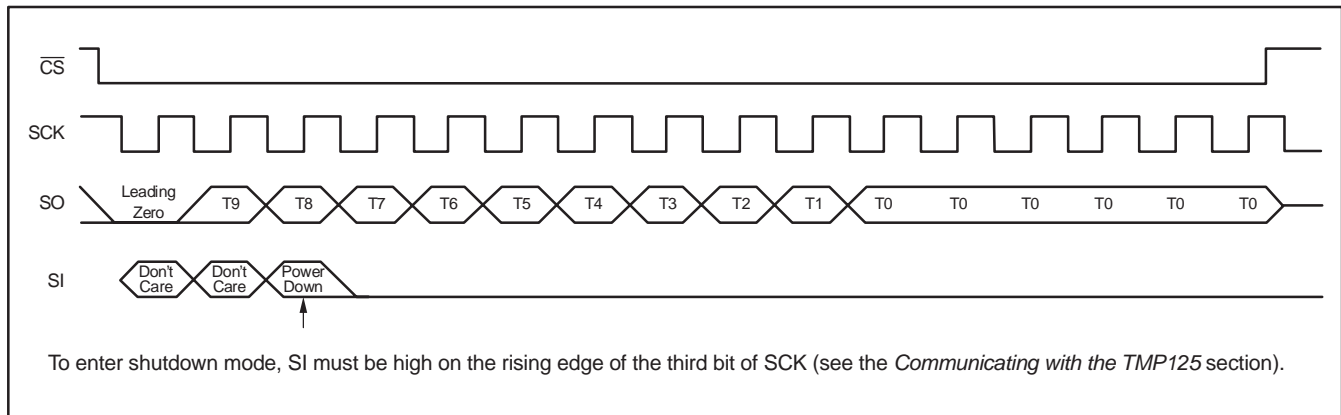

Figure 3. Data READ

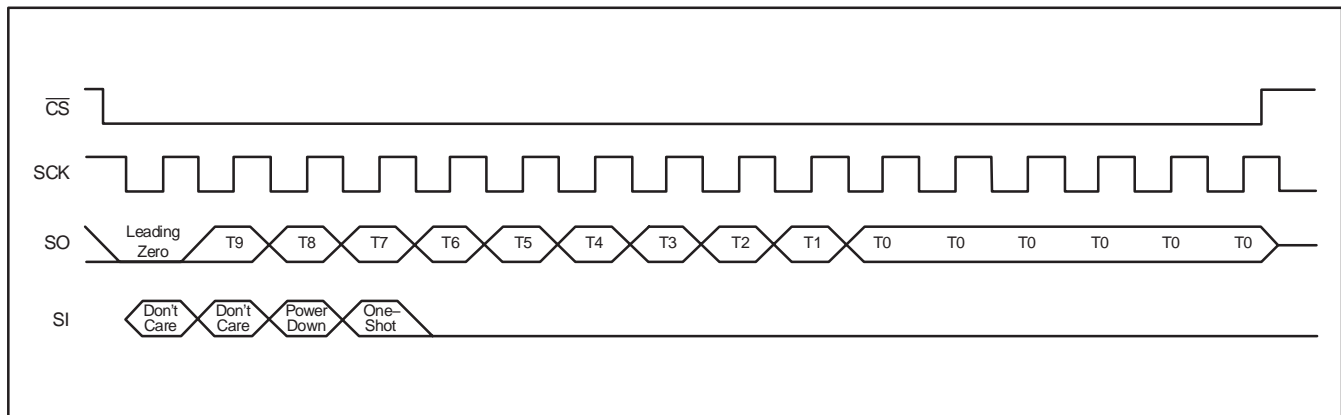

Figure 4. One-Shot Command

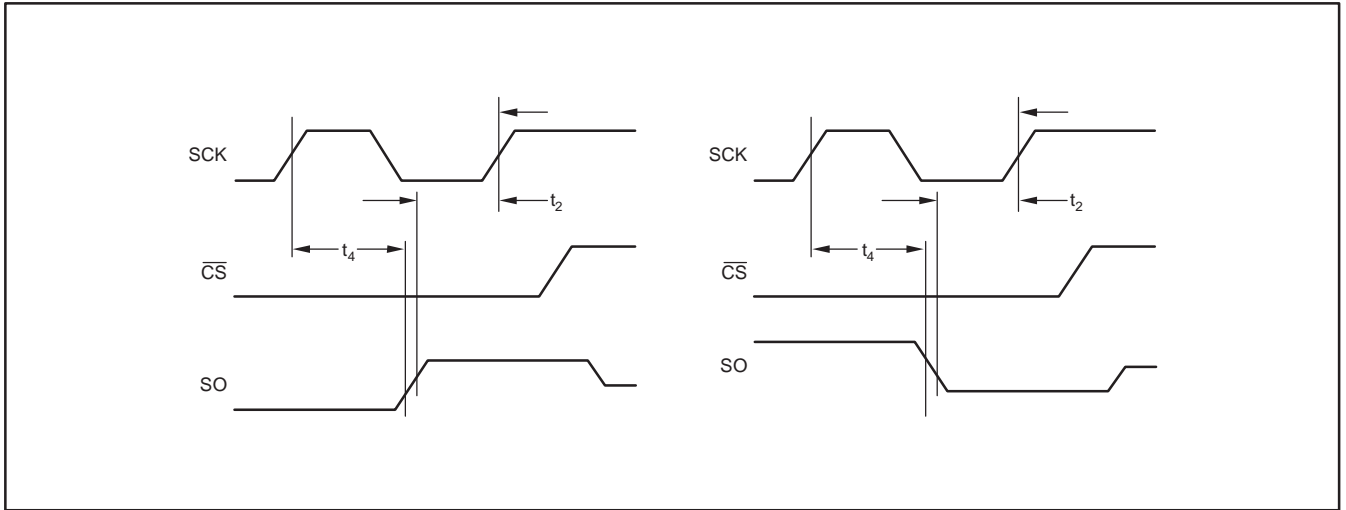

Figure 5. Input Data Timing Diagram

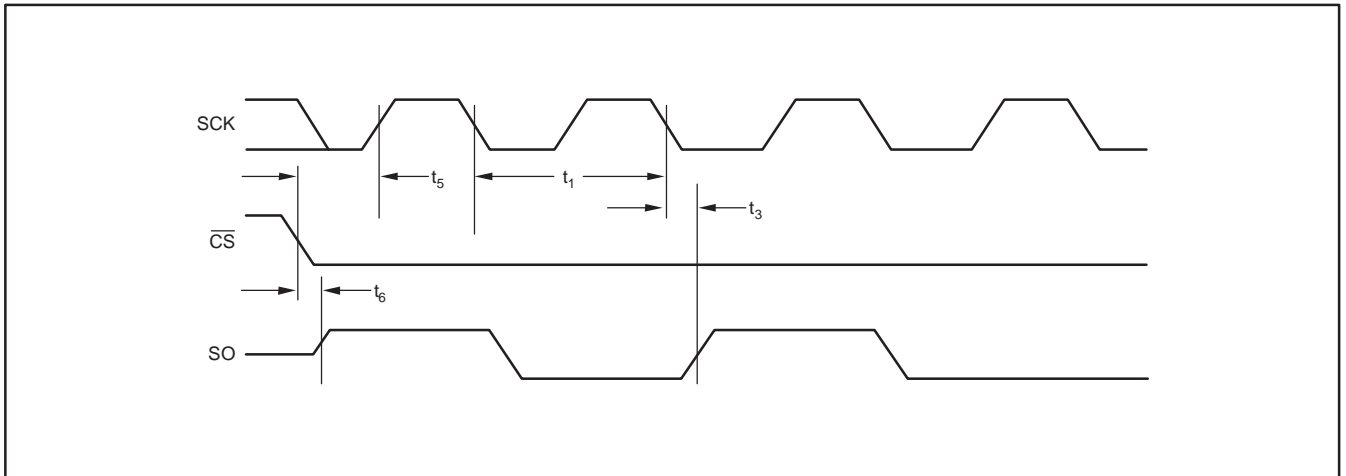

Figure 6. Output Data Timing Diagram

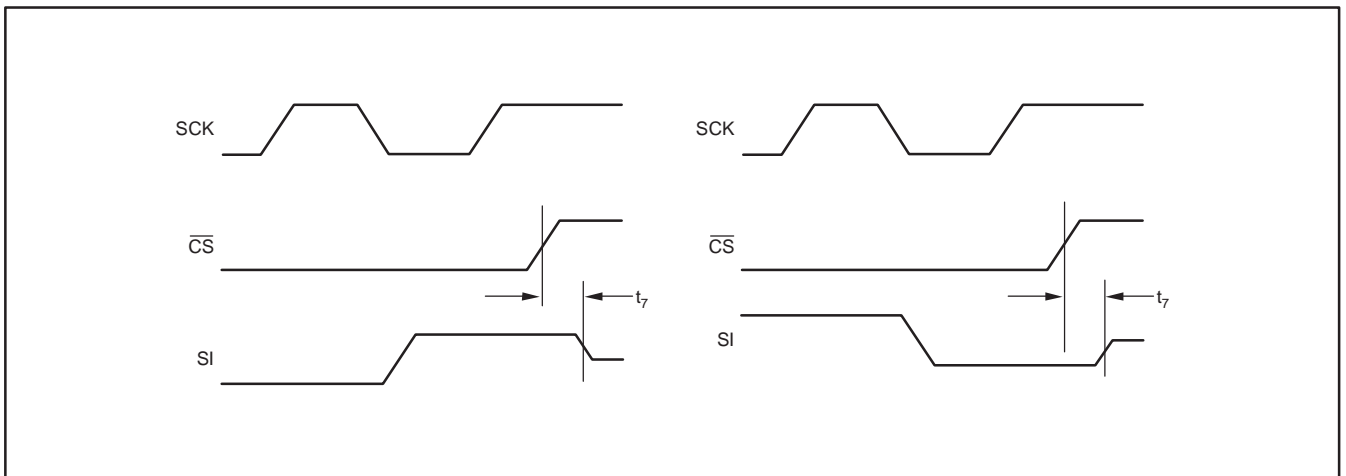

Figure 7. High Impedance Output Timing Diagram

PACKAGING INFORMATION

Orderable Device	Status (1)	Package Type	Package Drawing	Pins	Package Qty	Eco Plan (2)	Lead/Ball Finish (6)	MSL Peak Temp (3)	Op Temp (°C)	Device Marking (4/5)	Samples
HPA00444AIDBVT	ACTIVE	SOT-23	DBV	6	250	Green (RoHS & no Sb/Br)	CU NIPDAU	Level-2-260C-1 YEAR	-40 to 125	T125	Samples
TMP125AIDBVR	ACTIVE	SOT-23	DBV	6	3000	Green (RoHS & no Sb/Br)	CU NIPDAU	Level-2-260C-1 YEAR	-40 to 125	T125	Samples
TMP125AIDBVRG4	ACTIVE	SOT-23	DBV	6	3000	Green (RoHS & no Sb/Br)	CU NIPDAU	Level-2-260C-1 YEAR	-40 to 125	T125	Samples
TMP125AIDBVT	ACTIVE	SOT-23	DBV	6	250	Green (RoHS & no Sb/Br)	CU NIPDAU	Level-2-260C-1 YEAR	-40 to 125	T125	Samples
TMP125AIDBVTG4	ACTIVE	SOT-23	DBV	6	250	Green (RoHS & no Sb/Br)	CU NIPDAU	Level-2-260C-1 YEAR	-40 to 125	T125	Samples

(1) The marketing status values are defined as follows:

ACTIVE: Product device recommended for new designs.

LIFEBUY: TI has announced that the device will be discontinued, and a lifetime-buy period is in effect.

NRND: Not recommended for new designs. Device is in production to support existing customers, but TI does not recommend using this part in a new design.

PREVIEW: Device has been announced but is not in production. Samples may or may not be available.

OBSOLETE: TI has discontinued the production of the device.

(2) **RoHS:** TI defines "RoHS" to mean semiconductor products that are compliant with the current EU RoHS requirements for all 10 RoHS substances, including the requirement that RoHS substance do not exceed 0.1% by weight in homogeneous materials. Where designed to be soldered at high temperatures, "RoHS" products are suitable for use in specified lead-free processes. TI may reference these types of products as "Pb-Free".

RoHS Exempt: TI defines "RoHS Exempt" to mean products that contain lead but are compliant with EU RoHS pursuant to a specific EU RoHS exemption.

Green: TI defines "Green" to mean the content of Chlorine (Cl) and Bromine (Br) based flame retardants meet JS709B low halogen requirements of <=1000ppm threshold. Antimony trioxide based flame retardants must also meet the <=1000ppm threshold requirement.

(3) MSL, Peak Temp. - The Moisture Sensitivity Level rating according to the JEDEC industry standard classifications, and peak solder temperature.

(4) There may be additional marking, which relates to the logo, the lot trace code information, or the environmental category on the device.

(5) Multiple Device Markings will be inside parentheses. Only one Device Marking contained in parentheses and separated by a "-" will appear on a device. If a line is indented then it is a continuation of the previous line and the two combined represent the entire Device Marking for that device.

(6) Lead/Ball Finish - Orderable Devices may have multiple material finish options. Finish options are separated by a vertical ruled line. Lead/Ball Finish values may wrap to two lines if the finish value exceeds the maximum column width.

Important Information and Disclaimer: The information provided on this page represents TI's knowledge and belief as of the date that it is provided. TI bases its knowledge and belief on information provided by third parties, and makes no representation or warranty as to the accuracy of such information. Efforts are underway to better integrate information from third parties. TI has taken and continues to take reasonable steps to provide representative and accurate information but may not have conducted destructive testing or chemical analysis on incoming materials and chemicals. TI and TI suppliers consider certain information to be proprietary, and thus CAS numbers and other limited information may not be available for release.

In no event shall TI's liability arising out of such information exceed the total purchase price of the TI part(s) at issue in this document sold by TI to Customer on an annual basis.

TAPE AND REEL INFORMATION



QUADRANT ASSIGNMENTS FOR PIN 1 ORIENTATION IN TAPE



*All dimensions are nominal

Device	Package Type	Package Drawing	Pins	SPQ	Reel Diameter (mm)	Reel Width W1 (mm)	A0 (mm)	B0 (mm)	K0 (mm)	P1 (mm)	W (mm)	Pin1 Quadrant
TMP125AIDBVR	SOT-23	DBV	6	3000	178.0	9.0	3.23	3.17	1.37	4.0	8.0	Q3
TMP125AIDBVT	SOT-23	DBV	6	250	178.0	9.0	3.23	3.17	1.37	4.0	8.0	Q3

TAPE AND REEL BOX DIMENSIONS

*All dimensions are nominal

Device	Package Type	Package Drawing	Pins	SPQ	Length (mm)	Width (mm)	Height (mm)
TMP125AIDBVR	SOT-23	DBV	6	3000	445.0	220.0	345.0
TMP125AIDBVT	SOT-23	DBV	6	250	445.0	220.0	345.0

DBV0006A



PACKAGE OUTLINE

SOT-23 - 1.45 mm max height

SMALL OUTLINE TRANSISTOR

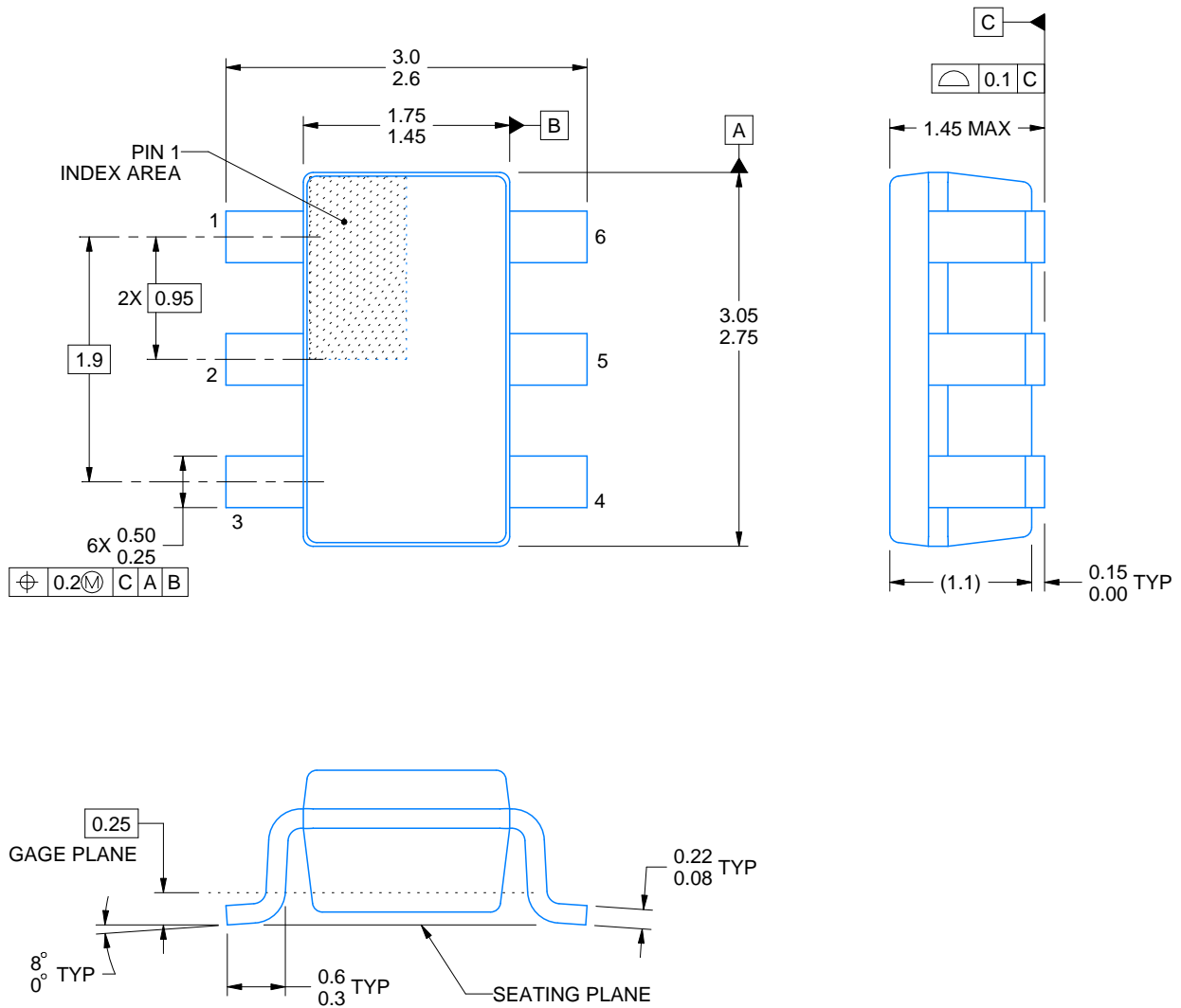

4214840/B 03/2018

NOTES:

1. All linear dimensions are in millimeters. Any dimensions in parenthesis are for reference only. Dimensioning and tolerancing per ASME Y14.5M.
2. This drawing is subject to change without notice.
3. Body dimensions do not include mold flash or protrusion. Mold flash and protrusion shall not exceed 0.15 per side.
4. Leads 1,2,3 may be wider than leads 4,5,6 for package orientation.
5. Reference JEDEC MO-178.

EXAMPLE BOARD LAYOUT

DBV0006A

SOT-23 - 1.45 mm max height

SMALL OUTLINE TRANSISTOR

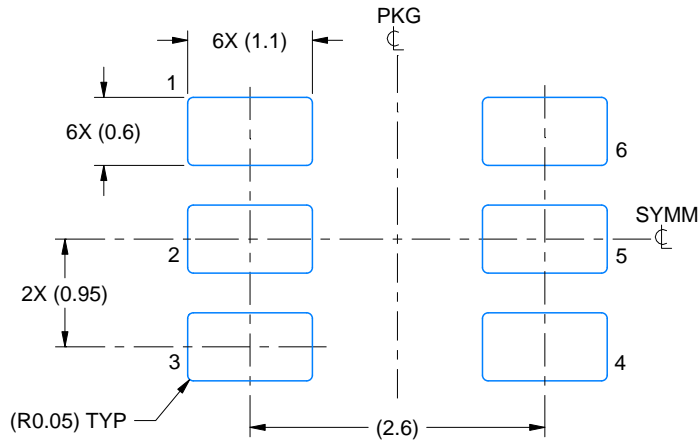

LAND PATTERN EXAMPLE
EXPOSED METAL SHOWN
SCALE:15X

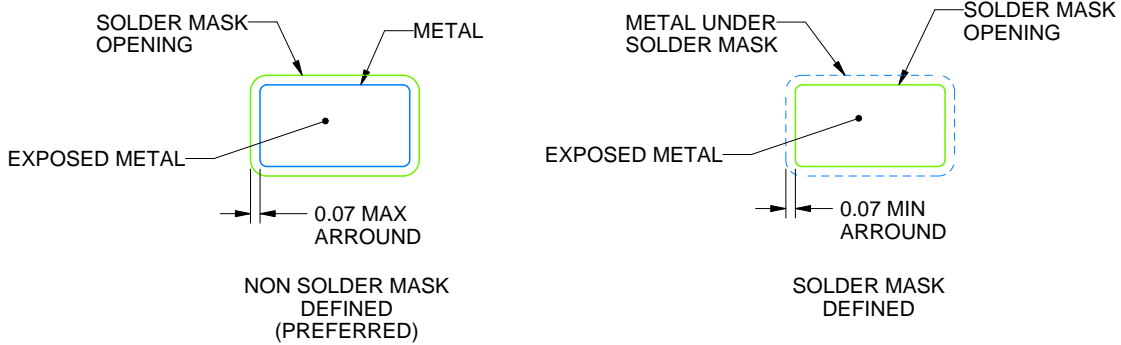

SOLDER MASK DETAILS

4214840/B 03/2018

NOTES: (continued)

6. Publication IPC-7351 may have alternate designs.

7. Solder mask tolerances between and around signal pads can vary based on board fabrication site.

EXAMPLE STENCIL DESIGN

DBV0006A

SOT-23 - 1.45 mm max height

SMALL OUTLINE TRANSISTOR

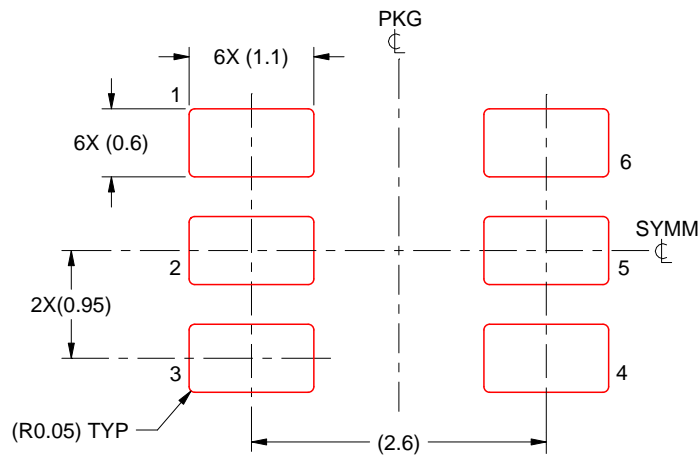

SOLDER PASTE EXAMPLE
BASED ON 0.125 mm THICK STENCIL
SCALE:15X

4214840/B 03/2018

NOTES: (continued)

8. Laser cutting apertures with trapezoidal walls and rounded corners may offer better paste release. IPC-7525 may have alternate design recommendations.
9. Board assembly site may have different recommendations for stencil design.

IMPORTANT NOTICE AND DISCLAIMER

TI PROVIDES TECHNICAL AND RELIABILITY DATA (INCLUDING DATASHEETS), DESIGN RESOURCES (INCLUDING REFERENCE DESIGNS), APPLICATION OR OTHER DESIGN ADVICE, WEB TOOLS, SAFETY INFORMATION, AND OTHER RESOURCES "AS IS" AND WITH ALL FAULTS, AND DISCLAIMS ALL WARRANTIES, EXPRESS AND IMPLIED, INCLUDING WITHOUT LIMITATION ANY IMPLIED WARRANTIES OF MERCHANTABILITY, FITNESS FOR A PARTICULAR PURPOSE OR NON-INFRINGEMENT OF THIRD PARTY INTELLECTUAL PROPERTY RIGHTS.

These resources are intended for skilled developers designing with TI products. You are solely responsible for (1) selecting the appropriate TI products for your application, (2) designing, validating and testing your application, and (3) ensuring your application meets applicable standards, and any other safety, security, or other requirements. These resources are subject to change without notice. TI grants you permission to use these resources only for development of an application that uses the TI products described in the resource. Other reproduction and display of these resources is prohibited. No license is granted to any other TI intellectual property right or to any third party intellectual property right. TI disclaims responsibility for, and you will fully indemnify TI and its representatives against, any claims, damages, costs, losses, and liabilities arising out of your use of these resources.

TI's products are provided subject to TI's Terms of Sale (www.ti.com/legal/termsofsale.html) or other applicable terms available either on ti.com or provided in conjunction with such TI products. TI's provision of these resources does not expand or otherwise alter TI's applicable warranties or warranty disclaimers for TI products.

Mailing Address: Texas Instruments, Post Office Box 655303, Dallas, Texas 75265
Copyright © 2019, Texas Instruments Incorporated

Looking for pricing, stock, or lifecycle information?

Click below to explore more details on WIN SOURCE:

 [View TMP125AIDBVTG4 on WIN SOURCE](#)

 [Texas Instruments](#) Information

Optimize Your Supply Chain with WIN SOURCE Solutions

-  Global Sourcing Solution
-  Obsolete Management
-  Cost Control Management
-  Shortage Management
-  Alternative Solution
-  Excess Inventory Management