

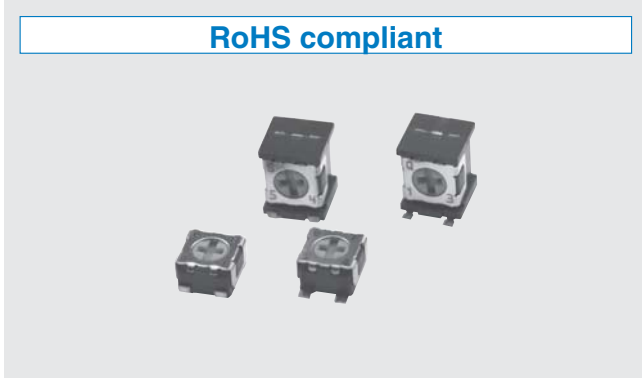

# THE DATASHEET OF ST32ETG101



**RoHS compliant**



**FEATURES**

- RoHS compliant
- Rotor with a cross slot for ease of adjustment
- Leaded terminals provide strong adhesive strength against P.C.B. bending
- J-hook, Gull wing and leaded terminal configurations
- Sealed (Washable: Refer to page 698.)

**INTERNAL STRUCTURE**



	Part name	Material	Flammability
①	Wiper	Multi metal alloy	—
②	Cover	Stainless steel (SUS 304)	
③	Housing	Epoxy	UL94V-0
④	Terminal pin	Copper alloy, Sn-Cu-plated	—
⑤	Base element	Ceramic	
⑥	“O” ring	Silicone rubber	UL94HB
⑦	Rotor	Polyphenylenesulphide	UL94V-0
⑧	Electrode	Ag-Pd cermet	—
⑨	Resistive element	RuO <sub>2</sub> cermet	

**PART NUMBER DESIGNATION**

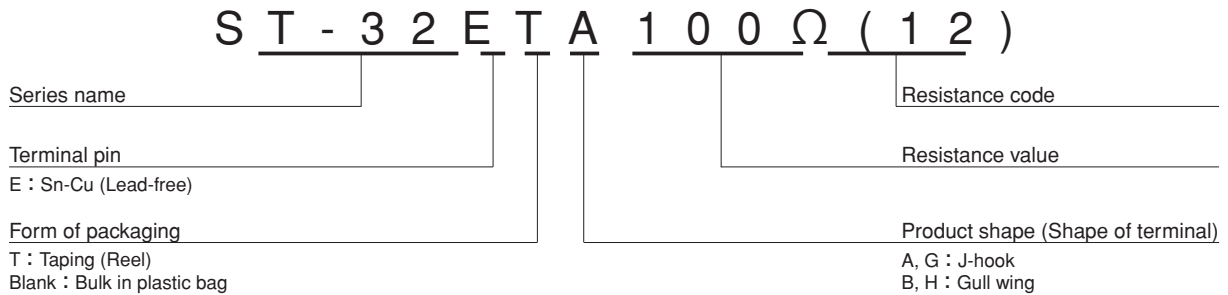

※ Please refer to the LIST OF PART NUMBERS when placing orders.

# ST-32

## SURFACE MOUNT TRIMMERS

### LIST OF PART NUMBERS

Adjustment position	Shape of terminal	Form of packaging	
		Taping (reel)	Plastic bag
Top adjustment	A (J-hook)	ST-32ETA	ST-32EA
	B (Gull wing)	ST-32ETB	ST-32EB
Side adjustment	G (J-hook)	ST-32ETG	ST-32EG
	H (Gull wing)	ST-32ETH	ST-32EH
Pieces in package		500 pcs./reel	100 pcs./pack

### ELECTRICAL CHARACTERISTICS

Nominal resistance range	10 Ω ~ 2 M Ω
Resistance tolerance	± 20 %
Power ratings	0.125 W (70 °C) 0 W (125 °C)
Resistance law	Linear law (B)
Maximum input voltage	DC200 V or power rating, whichever is smaller
Maximum wiper current	100 mA or power rating, whichever is smaller
Effective electrical angle	210 ° (1 turn)
End resistance	1 % or 2 Ω , whichever is greater
C.R.V.	1 % or 3 Ω , whichever is greater
Operating temp. range	- 55 ~ 125 °C
Temp. coefficient	10 Ω ~ 50 Ω : ± 250 10 <sup>-6</sup> /°C maximum 100 Ω ~ 2 M Ω : ± 100 10 <sup>-6</sup> /°C maximum
Insulation resistance	1000 M Ω minimum (DC500 V)
Dielectric strength	AC500 V, 60 s
Net weight	Approx. 0.05 g (ST-32EA, EB) Approx. 0.11 g (ST-32EG, EH)

### Reflow profile for soldering heat evaluation

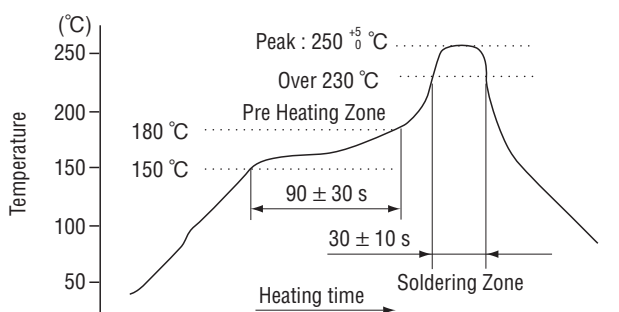

Reflow : two times maximum

### Nominal resistance values

10 Ω	20 Ω	50 Ω	100 Ω	200 Ω	300 Ω	500 Ω
1 k Ω	2 k Ω	3 k Ω	5 k Ω	10 k Ω	20 k Ω	30 k Ω
50 k Ω	100 k Ω	200 k Ω	500 k Ω	1 M Ω	2 M Ω	

Fig.1

The products indicated by ↻ mark are manufactured upon receipt of order basis.

※ The part numbers on the left are all available with the respective combination of <Nominal resistance values> (Fig. 1).

※ Verify the above part numbers when placing orders.

※ Taping specification is not sold separately and must be purchased in reel units.

### MECHANICAL CHARACTERISTICS

Mechanical angle	250 ° (1 turn)
Operating torque	5 mN·m {51 gf·cm} maximum
Stop strength	20 mN·m {204 gf·cm} minimum
Rotational life	100 cycles [ Δ R/R ≤ ± (2 Ω + 3 %)]
Thrust to rotor	5 N {0.51 kgf} minimum
Solderability	245 ± 3 °C, 2 ~ 3 s
Shear (Adhesion)	5 N {0.51 kgf} 10 s
Substrate bending	Width 90 mm, bend 3 mm, 5 s, 1 time
Pull-off strength	5 N {0.51 kgf} 10 s

{ } : Reference only

### ENVIRONMENTAL CHARACTERISTICS

Test item	Test conditions	Specifications
Thermal shock	- 65 ~ 125 °C (0.5 h), 5 cycles	[ Δ R/R ≤ 2 %] [S.S. ≤ 1 %]
Humidity	- 10 ~ 65 °C (80 ~ 98 %), 10 cycles, 240 h	[ Δ R/R ≤ 2 %]
Shock	981 m/s <sup>2</sup> , 6 ms 6 directions for 3 times each	[ Δ R/R ≤ 1 %] [S.S. ≤ 1 %]
Vibration	(Amplitude) 1.52 mm or (Acceleration) 196 m/s <sup>2</sup> , 10 ~ 2000 Hz, 3 directions, 12 times each	[ Δ R/R ≤ 1 %] [S.S. ≤ 1 %]
Load life	70 °C, 0.125 W, 1000 h	[ Δ R/R ≤ 3 %] [S.S. ≤ 1 %]
Low temp. operation	- 55 °C, 2 h	[ Δ R/R ≤ 2 %] [S.S. ≤ 2 %]
High temp. exposure	125 °C, 250 h	[ Δ R/R ≤ 3 %] [S.S. ≤ 2 %]
Immersion seal	85 °C, 60 s	No leaks (No continuous bubbles)
Soldering heat	Flow : 260 ± 3 °C as the temperature in a pot of molten solder, immersion from head of terminal to backside of board, 5 ~ 6 s, two times maximum. Reflow : Peak temperature 255 °C (Please refer to the profile below.) 手はんだ Manual soldering: 350 ± 10 °C, 3 ~ 4 s	[ Δ R/R ≤ 1 %]

Δ R/R : Change in total resistance  
S.S. : Setting stability

### MAXIMUM INPUT RATINGS

Nominal resistance values ( $\Omega$ )	Resistance code	Maximum input voltage (V)	Maximum wiper current (mA)
↻ 10	11	1.00	100
↻ 20	21	1.58	79.1
50	51	2.50	50.0
100	12	3.53	35.4
200	22	5.00	25.0
300	32	6.12	20.4
500	52	7.91	15.8
1 k	13	11.2	11.2
2 k	23	15.8	7.91
3 k	33	19.4	6.45
5 k	53	25.0	5.00
10 k	14	35.4	3.54
20 k	24	50.0	2.50
30 k	34	61.2	2.04
50 k	54	79.1	1.58
100 k	15	112	1.12
200 k	25	158	0.79
500 k	55	200	0.40
1 M	16	200	0.20
2 M	26	200	0.10

The products indicated by ↻ mark are manufactured upon receipt of order basis.

### RECOMMENDED P.C.B. PAD OUTLINE DIMENSIONS

#### ● ST-32EA, EG

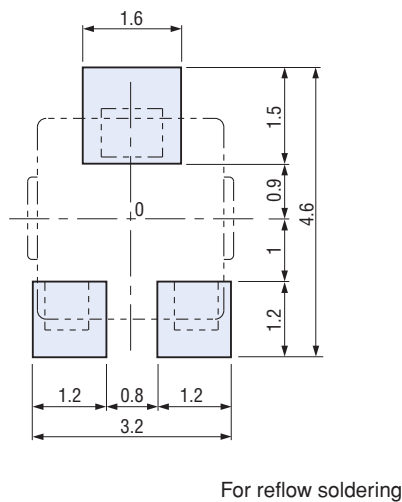

#### ● ST-32EB, EH



(Unit : mm)

Note) The zero point is the center of mounting.

# ST-32

## SURFACE MOUNT TRIMMERS

### OUTLINE DIMENSIONS

Unless otherwise specified, tolerance :  $\pm 0.3$  (Unit : mm)

#### ● ST-32EA Top adjustment

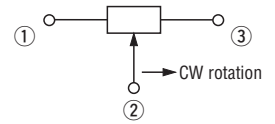

※ Note the terminal position.

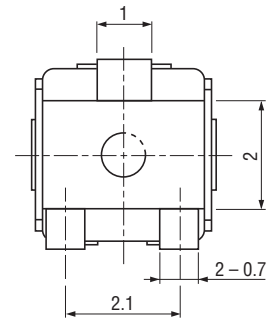
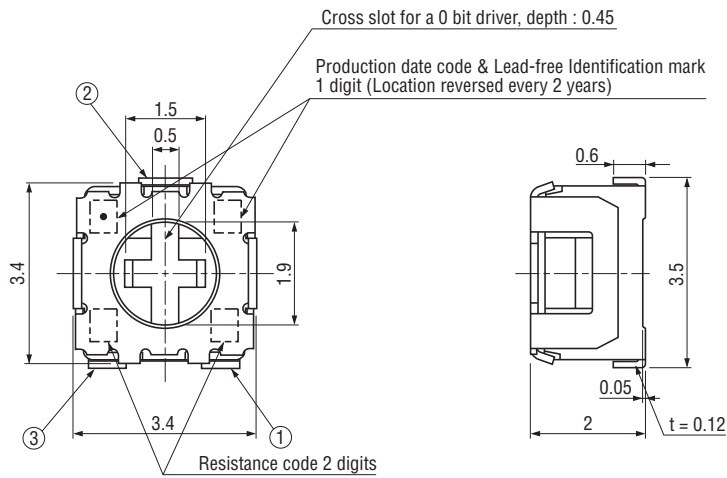

#### ● ST-32EB Top adjustment

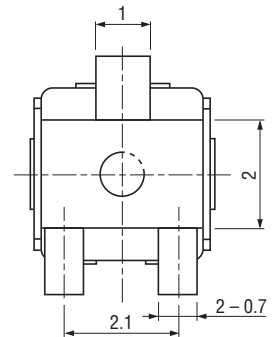
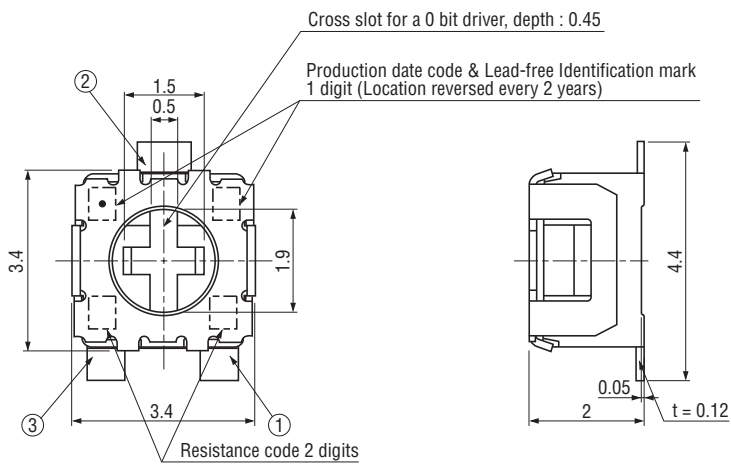

### OUTLINE DIMENSIONS

Unless otherwise specified, tolerance :  $\pm 0.3$  (Unit : mm)

#### ● ST-32EG

##### Side adjustment

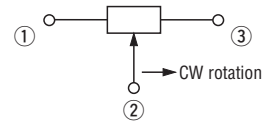

※ Note the terminal position.

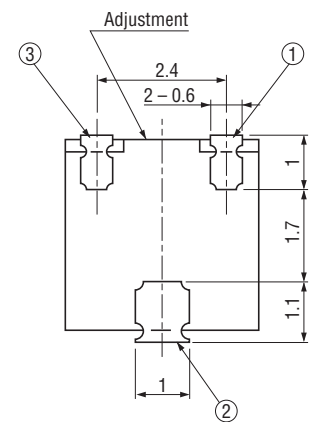

#### ● ST-32EH

##### Side adjustment

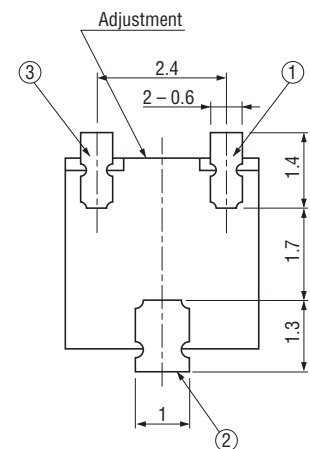

# ST-32

## SURFACE MOUNT TRIMMERS

### PACKAGING SPECIFICATIONS

#### <Taping packaging specifications>

- Taping version is packaged in 500 pcs. per reel.  
Orders will be accepted for units of 500 pcs., i.e., 500, 1000, 1500 pcs., etc.
- ST-32ETA, ETB versions are boxed with 4 reels (2000 pcs.). ST-32ETG, ETH versions are boxed with one reel (500 pcs.).

Maximum number of consecutive missing pieces = 2  
Leader length and reel dimension are shown in the diagrams below.

### EMBOSSED TAPE DIMENSIONS



### REEL DIMENSIONS

(Conforms to JIS C 0806-3)

(In accordance with EIAJ ET-7200A)

(Unit: mm)

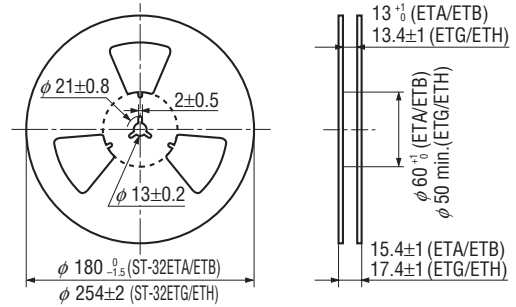

### ST-32ETA, ETB

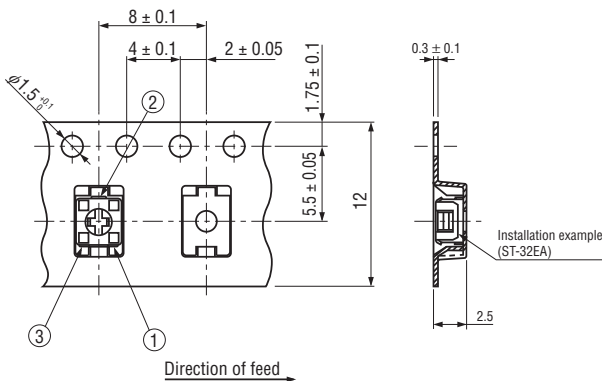

### ST-32ETG, ETH

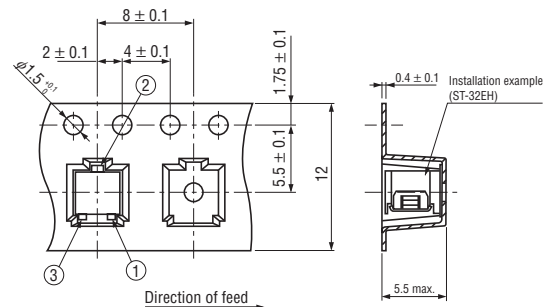



#### <Bulk pack specifications>

- Unit of bulk in a plastic bag is 100 pcs. per pack.
- Boxing of bulk in a plastic bag is performed with 500 pcs. per box.

## Looking for pricing, stock, or lifecycle information?

Click below to explore more details on WIN SOURCE:

-  [View ST32ETG101 on WIN SOURCE](#)
-  [Copal Electronics Inc. Information](#)

## Optimize Your Supply Chain with WIN SOURCE Solutions

-  Global Sourcing Solution
-  Obsolete Management
-  Cost Control Management
-  Shortage Management
-  Alternative Solution
-  Excess Inventory Management