



THE DATASHEET OF CT6ETV102



SINGLE TURN CERMET TRIMMERS

CT-6

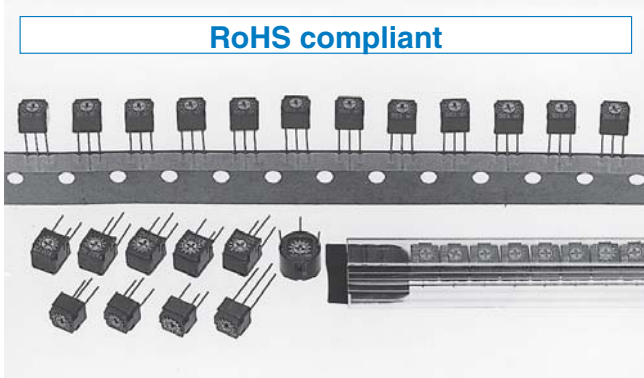

FEATURES

- RoHS compliant
- Various configurations to choose from
- Wide variety (14 types)
- "O" ring sealed and washable

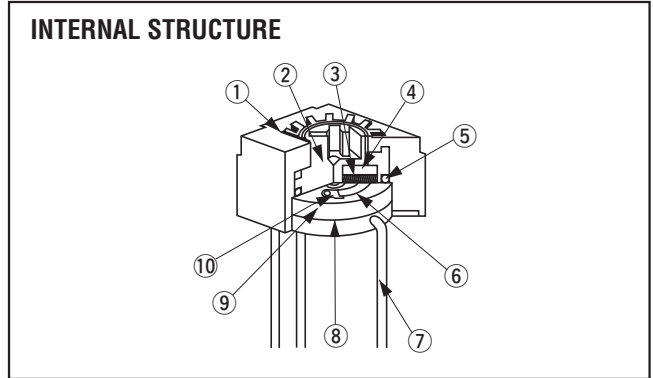

Part name	Material	Flammability
① Housing	Polybutyleneterephthalate	UL94V-0
② Rotor		
③ Wiper	Multi metal alloy	—
④ Rubber cushion	Silicone rubber	
⑤ "O" ring	Silicone rubber	UL94HB
⑥ Resistive element	RuO ₂ cermet	—
⑦ Terminal pin	Copper, Tin-plated	
⑧ Adhesive	Epoxy	UL94V-0
⑨ Base element	Ceramic	—
⑩ Electrode	Ag-Pd cermet	

PART NUMBER DESIGNATION

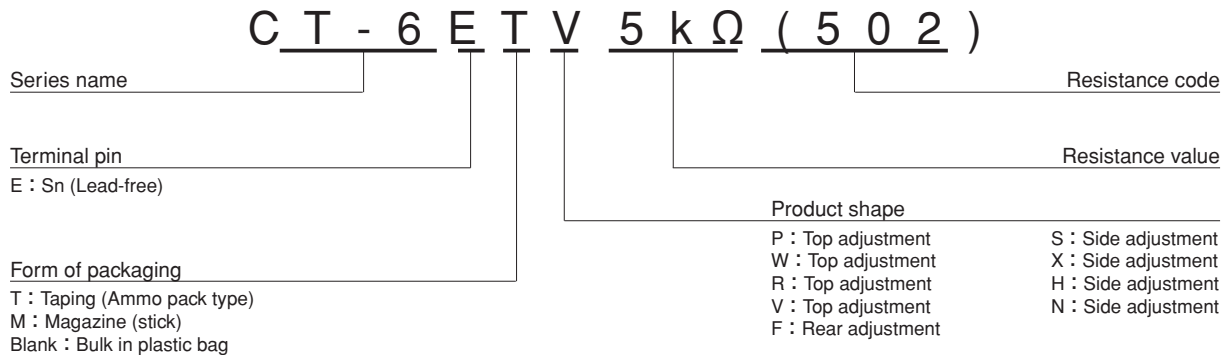

※ Please refer to the LIST OF PART NUMBERS when placing orders.

LIST OF PART NUMBERS

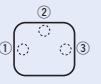
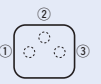
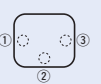
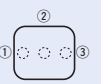
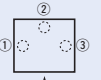
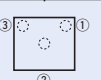
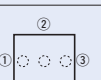
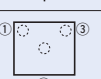
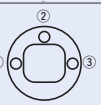
Adjustment position	Shape of terminal (Top view)	Form of packaging			Remarks
		Taping	Magazine (stick)	Plastic bag	
Top adjustment 		CT-6ETP Ammo pack type	CT-6EMP	CT-6EP	The pin length of CT-6ETP & CT-6EMP is different from CT-6EP.
				CT-6EW	—
				↻ CT-6ER	—
		CT-6ETV Ammo pack type		CT-6EV	—
Side adjustment (↑ Adjustment direction)			CT-6EMS	CT-6ES	The pin length of CT-6EMS is different from CT-6ES.
				CT-6EX	—
		CT-6ETH Ammo pack type		CT-6EH	The pin length of CT-6ETH is different from CT-6EH.
				CT-6EN	—
Rear adjustment				↻ CT-6EF	—
Pieces in package		1000 pcs./taping	75 pcs./stick	50 pcs./pack	—

☐ : Not manufactured

The products indicated by ↻ mark are manufactured upon receipt of order basis.

- ※ The above part numbers are all available with the respective combination of <Nominal resistance values> (Fig. 1).
- ※ Verify the above part numbers when placing orders.
- ※ Taping and magazine specifications are not sold separately and must be purchased in taping or stick units.

<Nominal resistance values>

Fig. 1

↻ 10 Ω	↻ 20 Ω	50 Ω	100 Ω	200 Ω	500 Ω
1 k Ω	2 k Ω	5 k Ω	10 k Ω	20 k Ω	50 k Ω
100 k Ω	200 k Ω	500 k Ω	1 M Ω	2 M Ω	

CT-6

CERMET TRIMMERS

ELECTRICAL CHARACTERISTICS

Nominal resistance range	10 Ω ~ 2 M Ω
Resistance tolerance	± 10 %
Power ratings	0.5 W (70 °C) 0 W (120 °C)
Resistance law	(B) Linear law
Maximum input voltage	DC200 V or power rating, whichever is smaller
Maximum wiper current	100 mA or power rating, whichever is smaller
Effective electrical angle	220 ° (1 turn)
End resistance	1 % or 2 Ω , whichever is greater
C.R.V.	1 % or 3 Ω , whichever is greater
Operating temp. range	— 55 ~ 120 °C
Temp. coefficient	10 Ω ~ 20 Ω : ± 250 10 ⁻⁶ /°C maximum 50 Ω ~ 2 M Ω : ± 100 10 ⁻⁶ /°C maximum
Insulation resistance	1000 M Ω minimum (DC500 V)
Dielectric strength	AC900 V, 60 s
Net weight	Approx. 0.51 g (CT-6EP, EW, ER, EV) Approx. 0.65 g (CT-6ES, EX, EH, EN) Approx. 0.92 g (CT-6EF)

MECHANICAL CHARACTERISTICS

Mechanical angle	260 ° (1 turn)
Operating torque	2 ~ 20 mN·m (20 ~ 204 gf·cm)
Stop strength	50 mN·m (510 gf·cm) minimum
Rotational life	200 cycles [Δ R/R ≤ ± (2 Ω +3 %)]
Terminal strength	10 N (1.02 kgf) minimum (Tensile strength)
Thrust to rotor	10 N (1.02 kgf) minimum
Solderability	245 ± 3 °C, 2 ~ 3 s

{ } : Reference only

ENVIRONMENTAL CHARACTERISTICS

Test item	Test conditions	Specifications
Thermal shock	— 65 ~ 125 °C (0.5 h), 5 cycles	[Δ R/R ≤ 1 %] [S.S. ≤ 1 %]
Humidity	— 10 ~ 65 °C (80 ~ 98 %), 10 cycles, 240 h	[Δ R/R ≤ 2 %]
Shock	981 m/s ² , 6 ms 6 directions for 3 times each	[Δ R/R ≤ 1 %] [S.S. ≤ 1 %]
Vibration	(Amplitude) 1.52 mm or (Acceleration) 196 m/s ² , 10 ~ 2000 Hz, 3 directions, 12 times each	
Load life	70 °C, 0.5 W, 1000 h	[Δ R/R ≤ 3 %] [S.S. ≤ 1 %]
Low temp. operation	— 55 °C, 2 h	[Δ R/R ≤ 2 %] [S.S. ≤ 2 %]
High temp. exposure	120 °C, 250 h	[Δ R/R ≤ 3 %] [S.S. ≤ 2 %]
Immersion seal	85 °C, 60 s	No leaks (No continuous bubbles)
Soldering heat	Flow : 260 ± 3 °C, 5 ~ 6 s, two times maximum Manual soldering : 380 ± 10 °C, 3 ~ 4 s	[Δ R/R ≤ 1 %]

Δ R/R : Change in total resistance
S.S. : Setting stability

MAXIMUM INPUT RATINGS

Nominal resistance values (Ω)	Resistance code	Maximum input voltage (V)	Maximum wiper current (mA)
↻ 10	100	1.00	100
↻ 20	200	2.00	100
↻ 50	500	5.00	100
100	101	7.07	70.7
200	201	10.0	50.0
500	501	15.8	31.6
1 k	102	22.4	22.4
2 k	202	31.6	15.8
5 k	502	50.0	10.0
10 k	103	70.7	7.07
20 k	203	100	5.00
50 k	503	158	3.16
100 k	104	200	2.00
200 k	204	200	1.00
500 k	504	200	0.40
1 M	105	200	0.20
2 M	205	200	0.10

The products indicated by ↻ mark are manufactured upon receipt of order basis.

OUTLINE DIMENSIONS

Unless otherwise specified, tolerance: ± 0.3 (Unit: mm)

CT-6EP Top adjustment

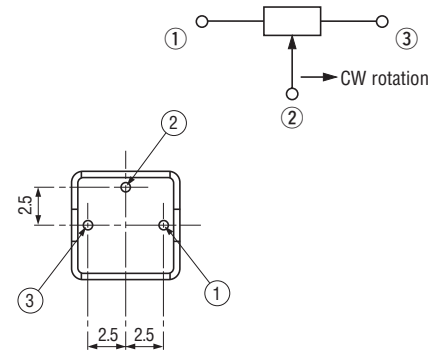
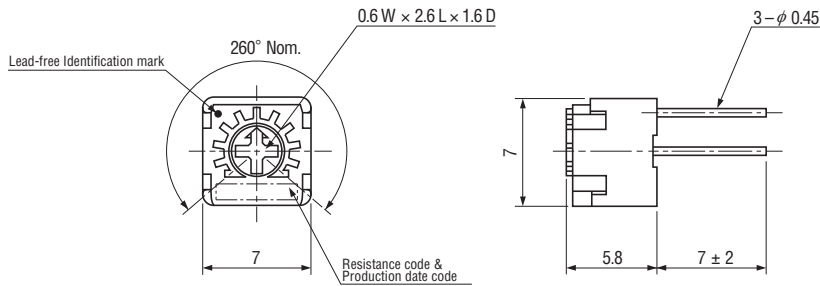

CT-6EW Top adjustment

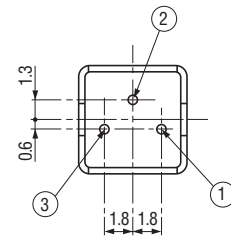
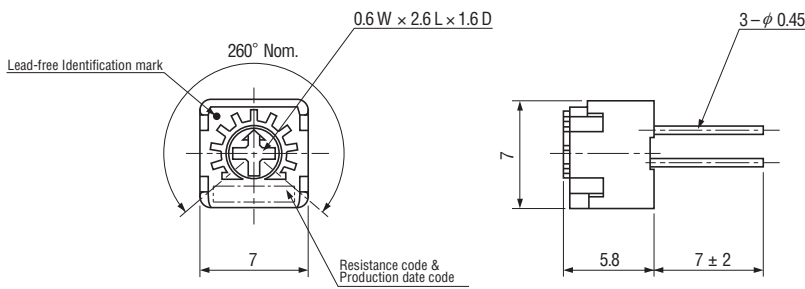

★ Pin pitch in W type is different from P type.

CT-6EV Top adjustment

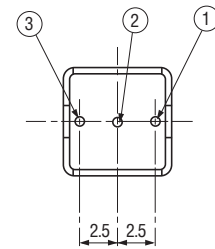
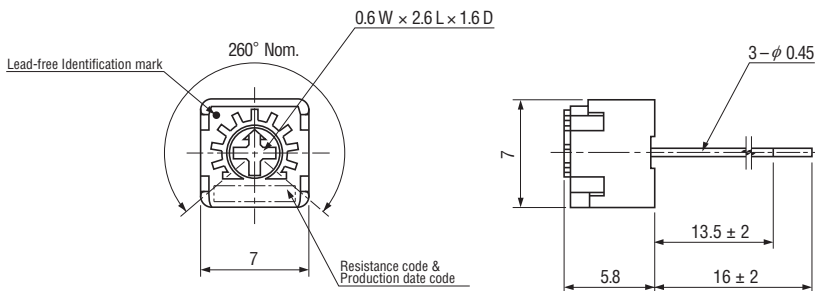

CT-6ES Side adjustment

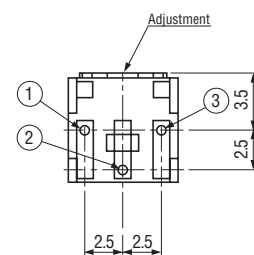
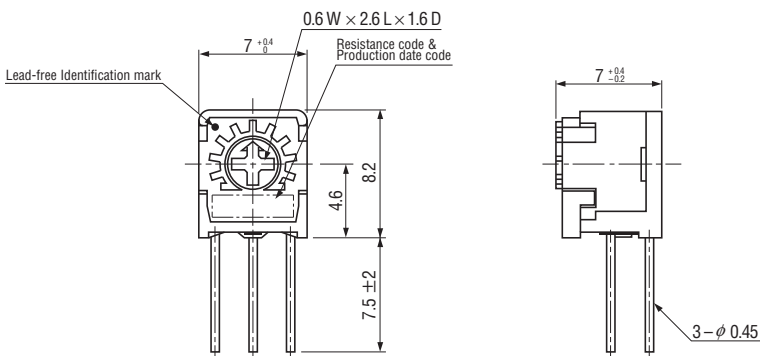

CT-6

CERMET TRIMMERS

OUTLINE DIMENSIONS

CT-6EX Side adjustment

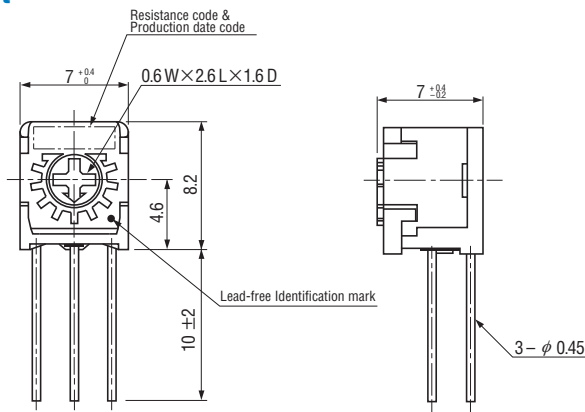

Unless otherwise specified, tolerance: ± 0.3 (Unit: mm)

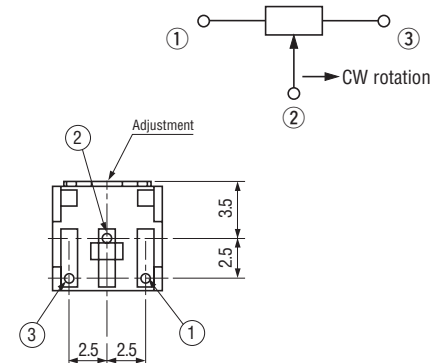

CT-6EH Side adjustment

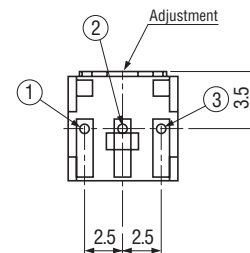
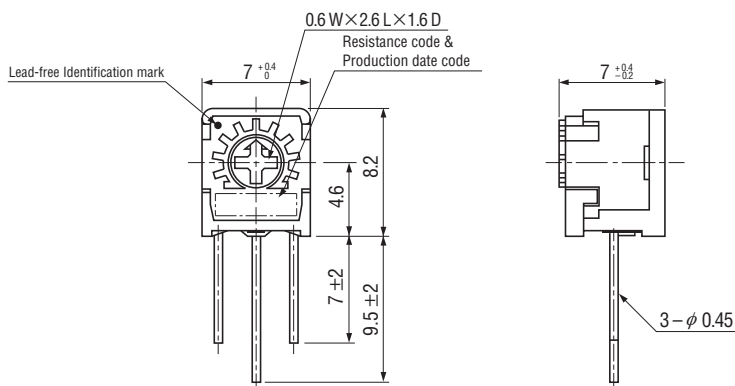

CT-6EN Side adjustment

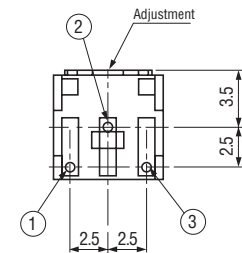
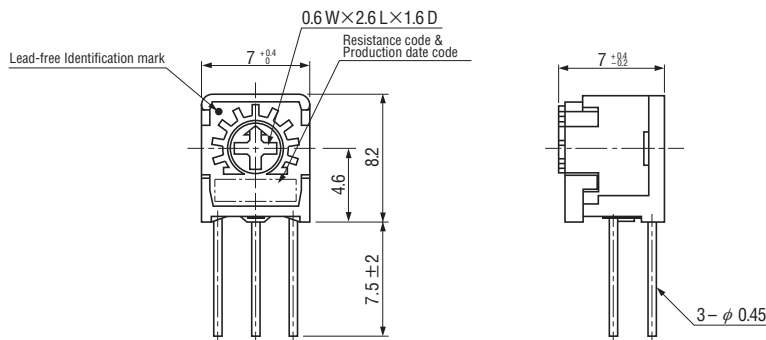

★ Terminals ① & ③ position in N type is different from X type.

OUTLINE DIMENSIONS

CT-6EF Rear adjustment

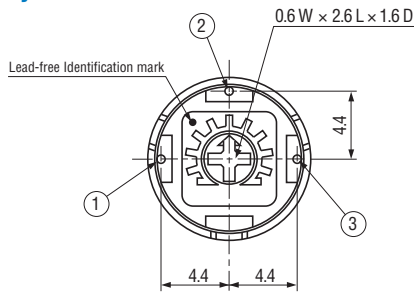

< Semi-standard products >

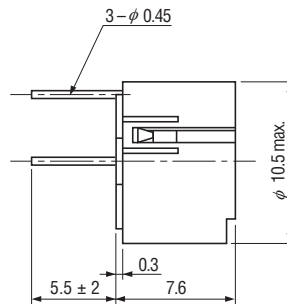

Unless otherwise specified, tolerance: ± 0.3 (Unit: mm)

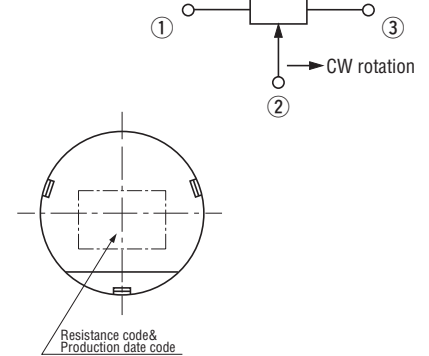

CT-6ER Top adjustment

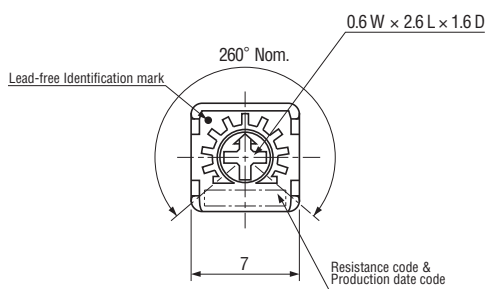

< Semi-standard products >

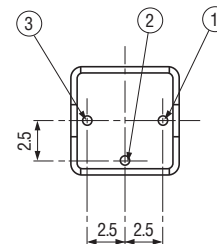
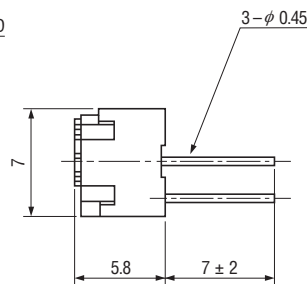

PACKAGING SPECIFICATIONS

<Taping packaging specifications>

- Taping version is packaged in 1000 pcs. per reel.
Orders will be accepted for units of 1000 pcs., i.e., 1000, 2000, 3000 pcs., etc.
- Taping version (ammo pack type) is boxed with one reel (1000 pcs.).

Ammo Pack

- Package size: 330 mm × 330 mm × 45 mm
- The leader and end of the tape have an empty part of minimum 300 mm respectively.
- There are two tape outlets on the package for different terminal alignment directions, for which details refer to the sketch above.
(e.g.) When the tape is fed from the right outlet marked ③, #3 terminal comes out first.
- Gross weight of the boxing version
 - ETV : Approx. 840 g
 - ETH : Approx. 930 g
 - ETP : Approx. 850 g

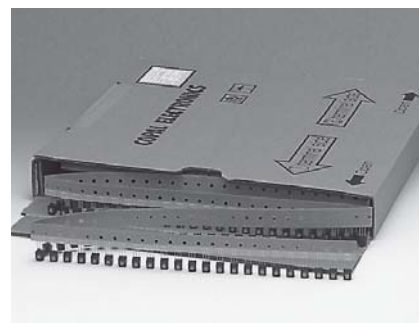

Ammo pack type

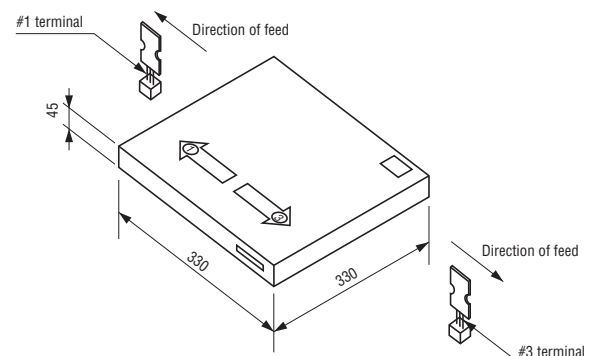

● CT-6ETP Top adjustment

Unless otherwise specified, tolerance: ± 0.3 (Unit: mm)

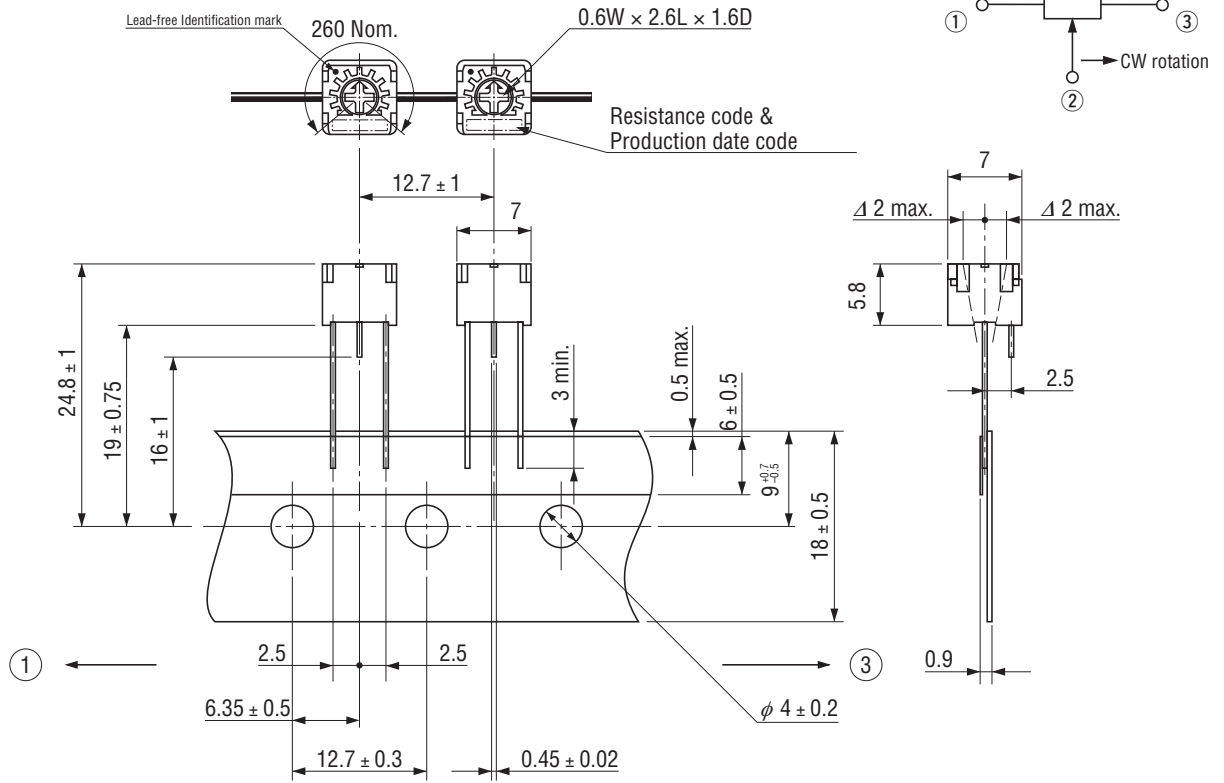

<Magazine packaging specifications>

- Magazine is packaged 75 pcs. per stick.
Orders will be accepted for units of 75 pcs. i.e., 150, 225 pcs., etc.
- Magazine is packed 3000 pcs. sticks per box.



Plastic magazine type

<Typical>

Plastic magazine length = 580 mm
(Without rubber cap)

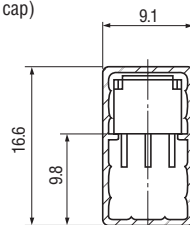

CT-6EMP

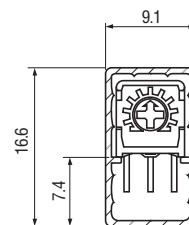

CT-6EMS

CT-6 CERMET TRIMMERS

● CT-6EMP Top adjustment

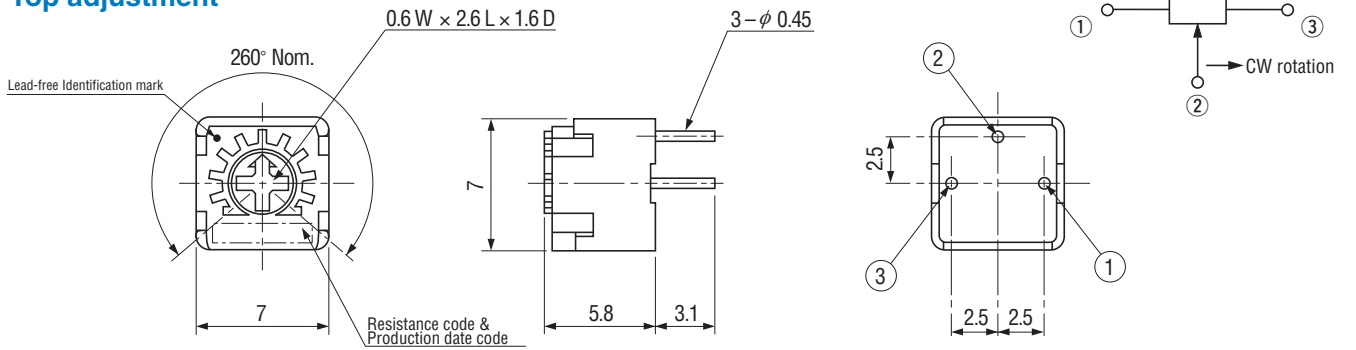

● CT-6EMS Side adjustment

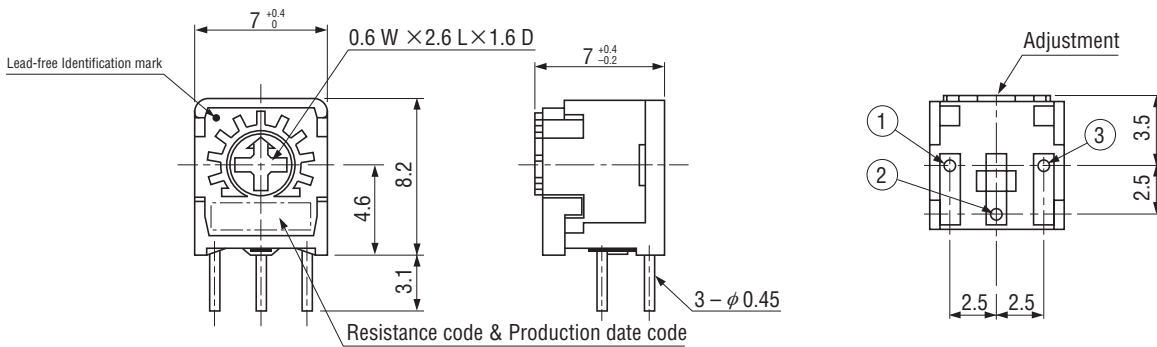

<Bulk pack specifications>

- Unit of bulk pack in a plastic bag is 50 pcs. per pack.
- Boxing of bulk in a plastic bag is performed with 200 pcs. (CT-6EF is 100 pcs.) per box.

■ ADJUSTMENT TOOL, MODEL TA-64

- Good for both minus and cross slot rotors / shafts.
- Recommended for use with the following copal trimmers.

Recommended models	
+ bit	- bit
CT-6	ST-4
FT-63	RJ-4
	RJ-6
	TM-7

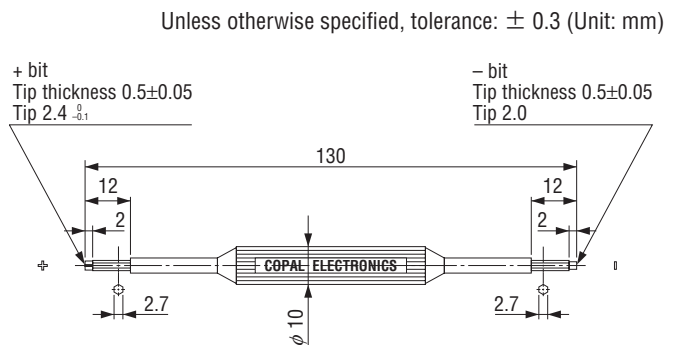



Material : Polyoxymethylene

※ Note : Please do not use the tool for purposes other than adjustment of electronic components.

Looking for pricing, stock, or lifecycle information?

Click below to explore more details on WIN SOURCE:

-  [View CT6ETV102 on WIN SOURCE](#)
-  [Copal Electronics Inc. Information](#)

Optimize Your Supply Chain with WIN SOURCE Solutions

-  Global Sourcing Solution
-  Obsolete Management
-  Cost Control Management
-  Shortage Management
-  Alternative Solution
-  Excess Inventory Management