



**THE DATASHEET OF  
BQ24352DSGT**



## Over-Voltage and Over-Current Charger Front-end Protection IC With Integrated Charging FET

Check for Samples: [bq24350](#) [bq24352](#)

### FEATURES

- **Robust Protection**
  - Input Over-Voltage Protection
  - Input Over-Current Protection
  - Accurate Battery Over-Voltage Protection
  - Thermal Shutdown
  - Output Short-Circuit Protection
- **Integrated Charging FET**
- **LDO Mode Operation**
- **Current Limited Power Supply for Host Controller**

- **Soft-Start to Prevent Inrush Currents**
- **Soft-Stop to Prevent Voltage Spikes**
- **30V Maximum Input Voltage**
- **Supports Up to 1A Load Current**
- **Small 2mm × 2mm 8pin SON Package**

### APPLICATIONS

- **Mobile Phones**
- **Low-Power Handheld Devices**

### DESCRIPTION

The bq24350/2 is a highly integrated circuit designed to provide protection to Li-ion batteries from failures of the charging circuit. The IC continuously monitors the input voltage and the battery voltage. In case of an input over-voltage condition, the IC will turn off the internal power FET after a blanking time. If the battery voltage rises to unsafe levels during charging process, power is removed from the system. If the input current exceeds the over current threshold for a limited time, the IC will turn off the output power. The integrated charging FET can regulate the charge voltage and current according to the control from the host. The device can also provide a voltage source with over voltage and over current protection for host controller.

**TYPICAL APPLICATION CIRCUIT**

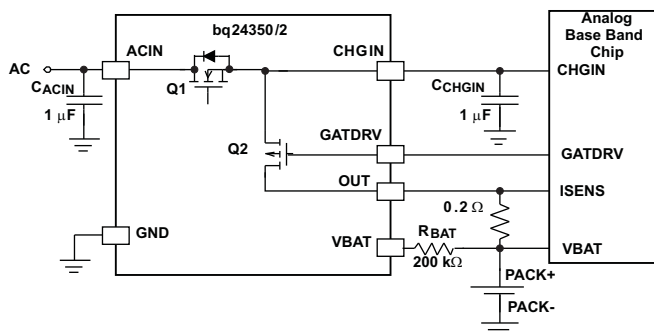

**PIN ASSIGNMENT**

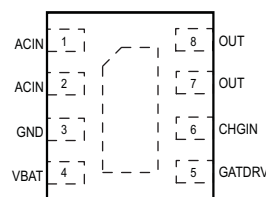

Please be aware that an important notice concerning availability, standard warranty, and use in critical applications of Texas Instruments semiconductor products and disclaimers thereto appears at the end of this data sheet.

PowerPAD is a trademark of Texas Instruments.



These devices have limited built-in ESD protection. The leads should be shorted together or the device placed in conductive foam during storage or handling to prevent electrostatic damage to the MOS gates.

### SIMPLIFIED FUNCTION BLOCK DIAGRAM

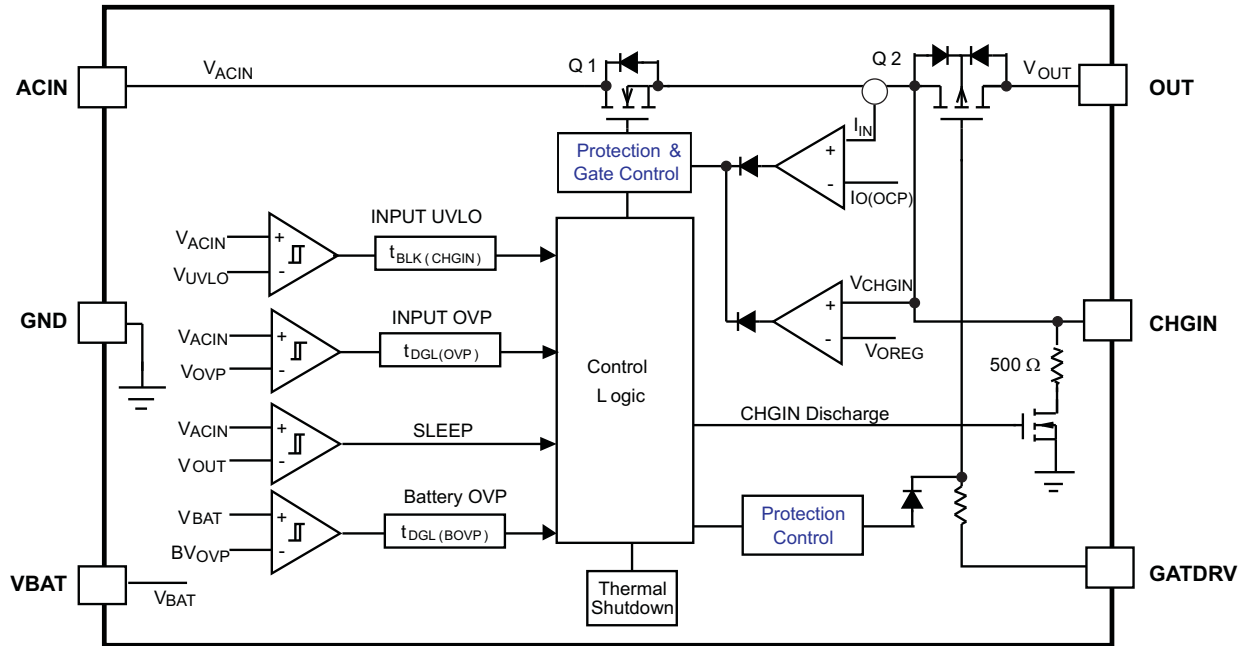

### PIN FUNCTIONS

PIN			
NAME	NUMBER	I/O	DESCRIPTION
ACIN	1,2	I	Power Supply Input, connect to an external DC supply. Connect an external 1µF ceramic capacitor (minimum) to GND.
OUT	7,8	O	Output terminal to the charging system.
VBAT	4	I	Battery voltage sense input. Connected to pack positive terminal through a resistor. Connected to ground if battery OVP function is not used.
GATDRV	5	I	P-FET gate drive input, connected to gate drive pin of the host charger controller
CHGIN	6	O	Output power pin for power input of host charger controller. Connect an external ceramic bypass capacitor (1.0µF minimum) to GND.
GND	3	-	Ground terminal
Thermal PAD			There is an internal electrical connection between the exposed thermal pad and the GND pin of the device. The thermal pad must be connected to the same potential as the GND pin on the printed circuit board. Do not use the thermal pad as the primary ground input for the device. GND pin must be connected to ground at all times.

### ORDERING INFORMATION

PART NUMBER	MARKING	MEDIUM	QUANTITY	PACKAGE	INPUT OVP THRESHOLD
bq24350DSGR	OAJ	Tape and Reel	3000	2mm x 2mm SON	6.17 V
bq24350DSGT	OAJ	Tape and Reel	250	2mm x 2mm SON	6.17 V
bq24352DSGR	OCY	Tape and Reel	3000	2mm x 2mm SON	7.1 V
bq24352DSGT	OCY	Tape and Reel	250	2mm x 2mm SON	7.1 V

## ABSOLUTE MAXIMUM RATINGS<sup>(1)</sup>

over operating free-air temperature range (unless otherwise noted)

		VALUE / UNIT
Input voltage	ACIN (with respect to GND)	–0.3 V to 30 V
Output voltage	OUT, CHGIN (with respect to GND)	–0.3 V to 7V
Input voltage	VBAT, GATDRV (with respect to GND)	–0.3 V to 7 V
Input current	ACIN	–1.8 A <sup>(2)</sup> to 1.4 A
Junction temperature, T <sub>J</sub>		–40°C to 150°C
Storage temperature, T <sub>STG</sub>		–65°C to 150°C

- (1) Stresses beyond those listed under absolute maximum ratings may cause permanent damage to the device. These are stress ratings only, and functional operation of the device at these or any other conditions beyond those indicated under recommended operating conditions is not implied. Exposure to absolute-maximum-rated conditions for extended periods may affect device reliability. All voltage values are with respect to the network ground terminal unless otherwise noted.
- (2) Reverse current is specified for a maximum of 50 hours at T<sub>J</sub> < 150°C.

## PACKAGE DISSIPATION RATINGS

PACKAGE	PACKAGE DRAWING	R <sub>θJC</sub>	R <sub>θJA</sub>
SON-8	DSG	5°C/W	75°C/W

## RECOMMENDED OPERATING CONDITIONS

		MIN	MAX	UNITS
V <sub>ACIN</sub>	ACIN voltage range	4.4	15	V
I <sub>ACIN</sub>	Current, ACIN pin		1	A
T <sub>J</sub>	Junction Temperature	–40	125	°C

## ELECTRICAL CHARACTERISTICS

Refer to the typical application circuit shown in [Figure 1](#) . These specifications apply over ACIN=5V, T<sub>J</sub> = -40~125°C, unless otherwise specified. Typical values are at T<sub>J</sub> = 25°C.

PARAMETER		TEST CONDITIONS	MIN	TYP	MAX	UNIT
<b>ACIN</b>						
V <sub>UVLO</sub>	Under-voltage lock-out threshold	ACIN: 3V → 2V, ACIN falling	1.8	1.95	2.1	V
		ACIN: 2V → 3V, ACIN rising	2.5			
t <sub>BLK(CHGIN)</sub>	Input power on blanking time	VACIN rising to CHGIN rising	10			ms
I <sub>DD</sub>	Operating current	No load on OUT and CHGIN pin	500			μA
<b>INPUT TO OUTPUT CHARACTERISTICS</b>						
	On resistance from ACIN to OUT	I <sub>OUT</sub> = 1.0A, ACIN=5V, GATDRV=0V	415	685	mΩ	
	On resistance from ACIN to CHGIN	I <sub>CHGIN</sub> = 1.0A, ACIN=5V, I <sub>OUT</sub> =0A	250	495	mΩ	
<b>INPUT OVER-VOLTAGE PROTECTION (OVP)</b>						
V <sub>OREG</sub>	CHGIN voltage in LDO mode	ACIN=5.9V, GATDRV=CHGIN, I <sub>CHGIN</sub> =0 to 1A.	5.33	5.5	5.66	V
V <sub>OVP</sub>	Input OVP threshold, bq24350	VACIN rising	6	6.17	6.35	V
	Input OVP threshold, bq24352		6.9	7.1	7.3	
V <sub>HYS-OVP</sub>	Input OVP recovery hysteresis, bq24350	VACIN: 7.5V → 5V	250	300	350	mV
	Input OVP recovery hysteresis, bq24352		100	150	200	
t <sub>DGL(OVP)</sub>	Input OVP deglitch time	VACIN rising to CHGIN falling	256			μS
t <sub>REC(OVP)</sub>	Input OVP recovery time	VACIN falling below V <sub>OVP</sub> to CHGIN rising	8.2			ms
<b>INPUT OVER CURRENT LIMITING AND PROTECTION (OCP)</b>						
I <sub>O(OCP)</sub>	OCP threshold		1.02	1.2	1.38	A
t <sub>DGL(OCP)</sub>	OCP blanking time		8.2			ms
t <sub>REC(OCP)</sub>	OCP recovery time		131			ms
<b>BATTERY OVER-VOLTAGE PROTECTION</b>						
BV <sub>OVP</sub>	Battery OVP threshold	VBAT rising	4.3	4.35	4.4	V
V <sub>HYS-BOVP</sub>	Battery OVP hysteresis	VBAT falling	200	250	300	mV
I <sub>VBAT</sub>	VBAT pin leakage current	VBAT=4.25V, series connection of a 200kΩ resistor, T <sub>J</sub> = 25°C	10			nA
t <sub>DGL(BOVP)</sub>	Battery OVP deglitch time	VBAT rising to CHGIN falling	8.2			ms
t <sub>REC(BOVP)</sub>	Battery OVP recovery time	VBAT falling below BVOVP to CHGIN rising	131			ms
<b>CHGIN</b>						
V <sub>SEXIT</sub>	Sleep mode exit threshold and CHGIN turn on threshold, ACIN-VOUT	ACIN rising, VOUT = 4.2 V	24	90	160	mV
V <sub>SENTRY</sub>	Sleep mode entry threshold and CHGIN turn off threshold, ACIN-VOUT	ACIN falling, VOUT = 4.2 V	10	55	105	mV
I <sub>DDSLP</sub>	Sleep Mode supply current	OUT = 4.2 V, GATDRV = 4.2 V, ACIN = VSS	10			μA
R <sub>DIS</sub>	CHGIN discharge resistor		500			Ω
	Leakage current from OUT to CHGIN	OUT = 4.2 V, GATDRV = 4.2 V, CHGIN = 0 V, ACIN = 0 V, T <sub>J</sub> = 85°C	1			μA
<b>INTEGRATED P-FET PARAMETERS</b>						
V <sub>t</sub>	Threshold Voltage, CHGIN-GATDRV.	CHGIN=5V, OUT=3.6V, I <sub>OUT</sub> =10mA	500	680	800	mV
I <sub>g</sub>	GATDRV pin leakage current		0.1	1		μA
I <sub>off</sub>	Off state leakage current at OUT pin.	ACIN=5V, GATDRV=CHGIN, OUT=0V	1			μA
R <sub>onp</sub>	On Resistance of P-FET (from CHGIN to OUT)	I <sub>OUT</sub> = 1.0A, ACIN=5V, GATDRV=0V	165	225		mΩ
G <sub>m</sub>	Forward Transconductance	ACIN=5V, I <sub>OUT</sub> =5mA, GATDRV=3.5V	27			mA/V
C <sub>g</sub>	Input capacitance at the GATDRV pin	CHGIN=GATDRV=5V	104			pF
<b>THERMAL PROTECTION</b>						
T <sub>J(OFF)</sub>	Thermal shutdown threshold	Junction temperature rising	140	150	160	°C

### ELECTRICAL CHARACTERISTICS (continued)

Refer to the typical application circuit shown in [Figure 1](#) . These specifications apply over ACIN=5V, T<sub>J</sub> = -40~125°C, unless otherwise specified. Typical values are at T<sub>J</sub> = 25°C.

PARAMETER	TEST CONDITIONS	MIN	TYP	MAX	UNIT
T <sub>J(OFF-HYS)</sub> Thermal shutdown hysteresis	Junction temperature falling		20		°C

### TYPICAL APPLICATION CIRCUIT

ACIN=5V, ICHARGE=1A, VBAT=4.2V

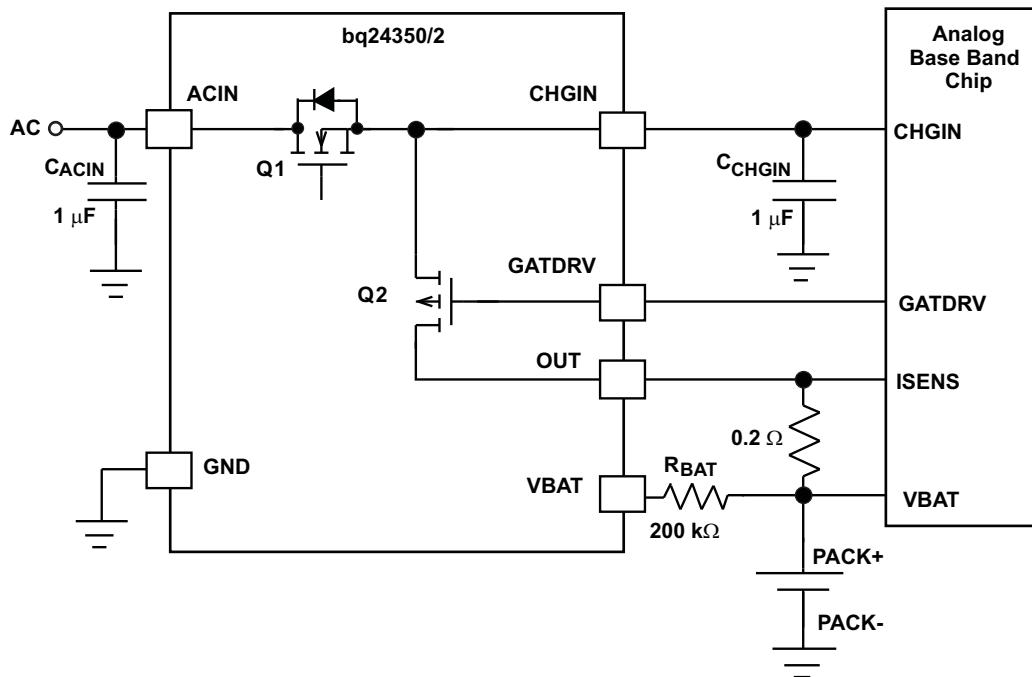

Figure 1. Host Controlled One-Cell Charger Application Circuit

### TYPICAL PERFORMANCE CHARACTERISTICS

Using circuit shown in typical application circuit [Figure 1](#), T<sub>A</sub> = 25°C, unless otherwise specified.

#### ACIN RAMP UP

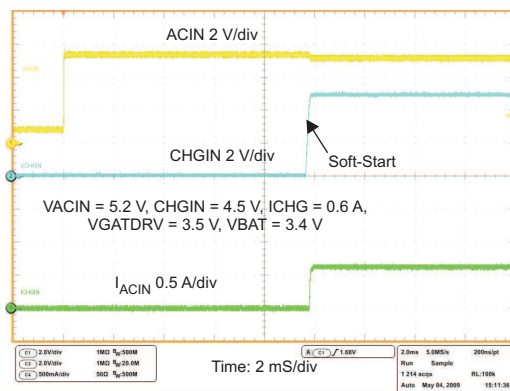

Figure 2.

#### ACIN RAMP DOWN

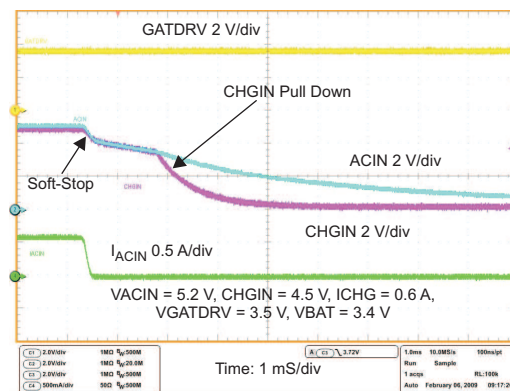

Figure 3.

TYPICAL PERFORMANCE CHARACTERISTICS (continued)

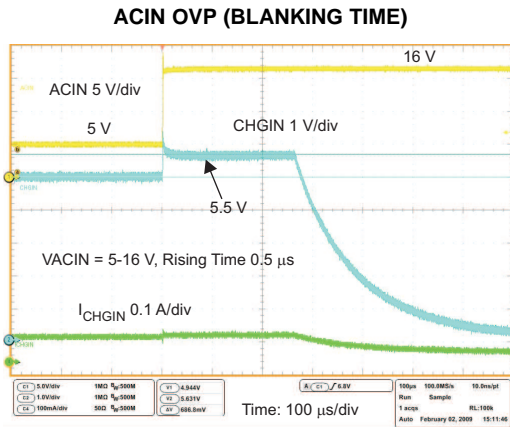

Figure 4.

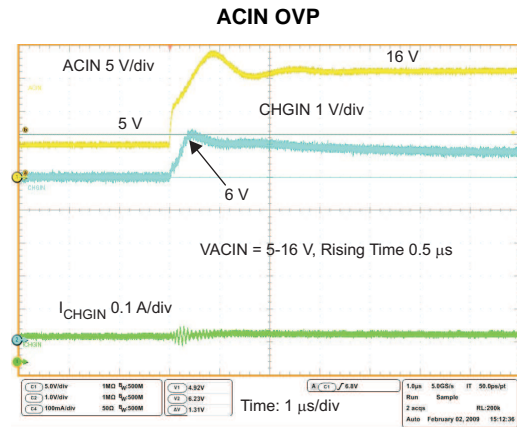

Figure 5.

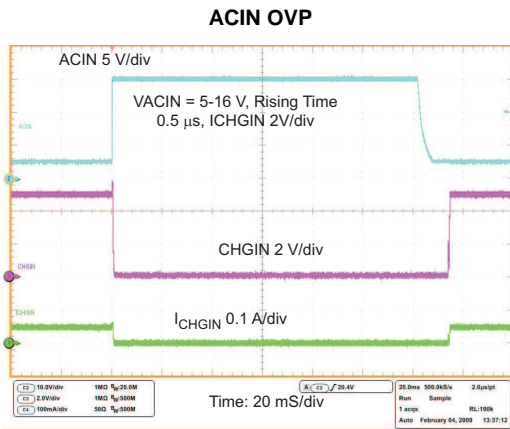

Figure 6.

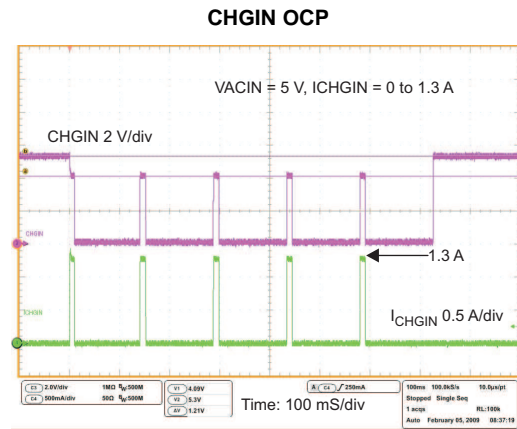

Figure 7.

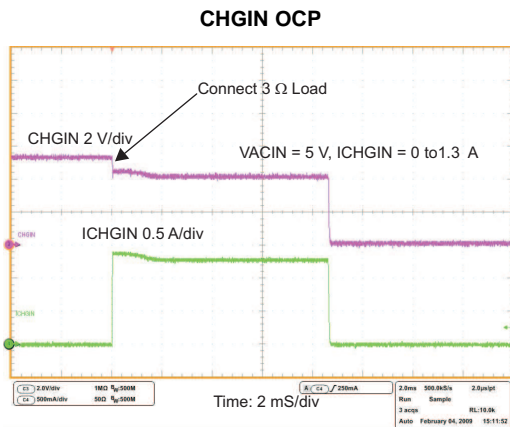

Figure 8.

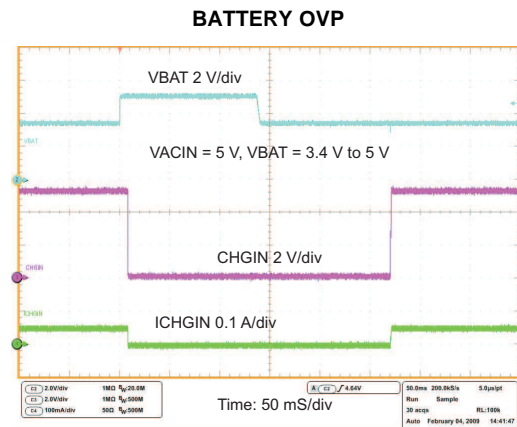

Figure 9.

TYPICAL PERFORMANCE CHARACTERISTICS (continued)

BATTERY OVP

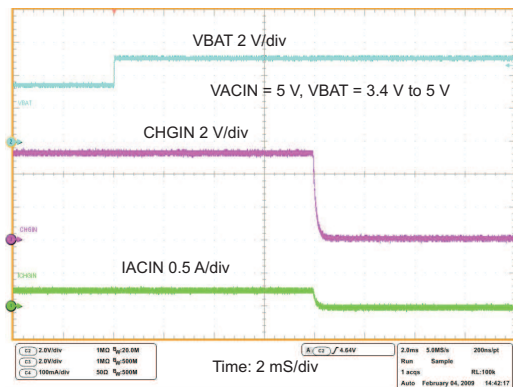

Figure 10.

Rdson vs Vgs

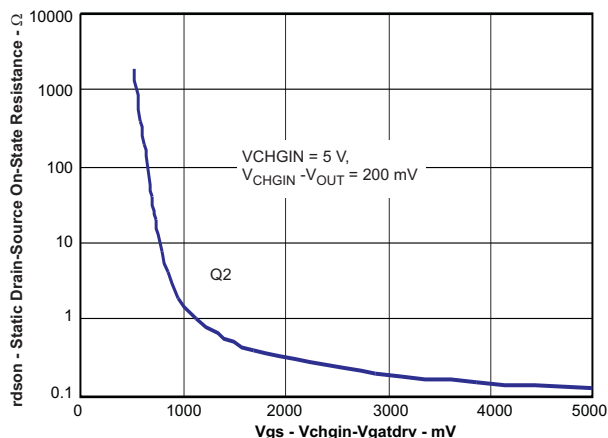

Figure 11.

FET ON RESISTANCE vs TEMPERATURE

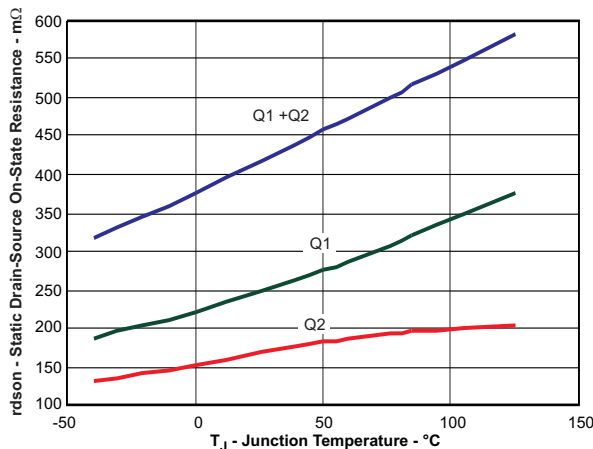

Figure 12.

BACKGROUND

During the charging process for portable devices, input voltage spikes usually happen when the AC/DC adaptor is plugged in, or charge current is cut off quickly under fault conditions, such as input OVP, OCP or battery OVP and so on. The over voltage stress may damage the analog baseband chip which has lower voltage rating due to its increased complexity. Therefore, over voltage protection is needed for the safe operation of portable devices. Another challenge arises from the charge circuit that uses external charging FET in series with a reverse blocking diode as the charging device. The battery may not be fully charged when input voltage is low due to the additional diode voltage drop. bq24350/2 will provide the solution for above problems since it has input OVP, OCP, battery OVP function, together with integrated charging FET which will eliminate the reverse blocking diode in the previously mentioned charge circuit, as shown in Figure 1.

DETAILED FUNCTIONAL DESCRIPTION

The bq24350/2 is a highly integrated circuit designed to provide protection to Li-ion batteries from failures of the charging circuit. The IC continuously monitors the input voltage and the battery voltage. In case of an input over-voltage condition, the IC will turn off the internal power FET after a blanking time. If the battery voltage rises to unsafe levels during charging process, power is removed from the system. If the input current exceeds the over current threshold for a limited time, the IC will turn off the output power. The integrated charging FET can regulate the charge voltage and current according to the control from the host. The device can also provide a voltage source with over voltage and over current protection for host controller.

## POWER DOWN

The device remains in power down mode when the input voltage at the ACIN pin is below the under-voltage threshold  $V_{UVLO}$ . The FET Q1 and Q2 connected between ACIN and OUT pins are off.

## POWER-ON RESET

The device resets when the input voltage at the ACIN pin exceeds the UVLO threshold. All internal counters and other circuit blocks are reset. The IC then waits for duration  $t_{BLK(CHGIN)}$  for the input voltage to stabilize. If, after  $t_{BLK(CHGIN)}$ , the input voltage and battery voltage are in normal range, FET Q1 is turned ON. The IC has a soft-start feature to control the inrush current. The soft-start minimizes the ringing at the input, where the ringing occurs because the parasitic inductance of the adapter cable and the input bypass capacitor form a resonant circuit. Once the soft-start sequence starts, the IC monitors the load current. If the load current is larger than  $I_{O(OC)}$  for more than  $t_{DGL(OC)}$ , FET Q1 and Q2 are switched off. The IC then repeats the power-on sequence after  $t_{REC(OC)}$ .

When a short-circuit is detected at power-on and Q1 is switched off, to prevent the input voltage from spiking up due to resonance between the inductance of the input cable and the input capacitor, Q1 is turned off slowly by reducing its gate-drive gradually, resulting in a “soft-stop”.

## SLEEP MODE

When ACIN falls to below sleep mode entry threshold ( $V_{SENTRY}$ ), the device operates in sleep mode and turns off Q1 and Q2 by internal circuit regardless of the gate drive signal from GARDRV pin. The device exits sleep mode when ACIN rising to above sleep mode exit threshold ( $V_{SEXIT}$ ). In this way, the device behaves like a diode and no external reverse blocking diode is needed in the application circuit.

## OPERATING

The device continuously monitors the input voltage, the input current and the battery voltage as described in detail below:

### Input Over-Voltage Protection and LDO Mode Operation

The CHGIN output of the IC operates similar to a linear regulator. Figure 13 shows the typical input OVP performance. When the ACIN input voltage is less than  $V_{O(REG)}$ , and above the  $V_{UVLO}$ , the CHGIN output voltage tracks the input voltage with a voltage drop caused by  $R_{DS(on)}$  of the protection FET Q1. When the ACIN input voltage is greater than  $V_{O(REG)}$  plus the  $R_{DS(on)}$  drop of Q1, and less than  $V_{OVP}$ , the CHGIN output voltage is regulated to  $V_{O(REG)}$ , and this is also referred as LDO mode operation. If the input voltage rises above  $V_{OVP}$ , the internal FET Q1 and Q2 are turned off after a blanking time of  $t_{DGL(OVP)}$ , removing power from the circuit. When the input voltage drops below  $V_{OVP} - V_{HYS-OVP}$ , and is still above  $V_{UVLO}$ , the FET Q1 and Q2 are turned on again after a deglitch time of  $t_{REC(OVP)}$ , which ensures that the input supply is stabilized when the IC starts up again.

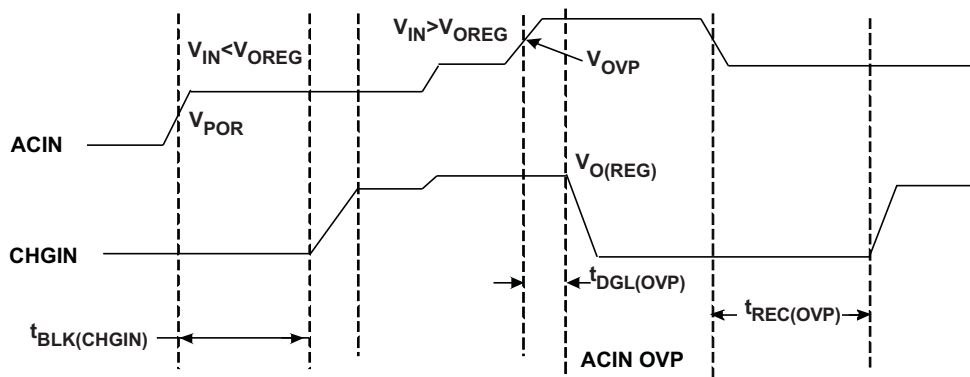

Figure 13. Input OVP Timing Diagram

### Over Current Limiting and Protection

The device includes a low drop out linear current regulator. This current regulator uses Q1 as the controlling

power device. Once the soft start sequence starts, the input current is limited to the Over Current Protection (OCP) threshold,  $I_{O(OC)}$ . If the input current through the IC attempts to exceed the OCP threshold, the switch Q1 is opened only enough to maintain the current at the OCP level. If the current limiting condition is maintained longer than the deglitch time,  $t_{DGL(OC)}$ , both the switch Q1 and Q2 are opened completely, as shown in Figure 14. In this fault case, the switch Q1 is turned off slowly, typically taking 100 $\mu$ S.

Once the OCP feature has been activated, the switch Q1 and Q2 will remain off for the OCP recovery time,  $t_{REC(OC)}$ . Following this time the switch will turn on, using soft start sequence. If the current through the IC remains below the OCP threshold, the switch will remain closed and normal operation resumes. If the current through the IC attempts to exceed the OCP threshold again, the operation described above repeats.

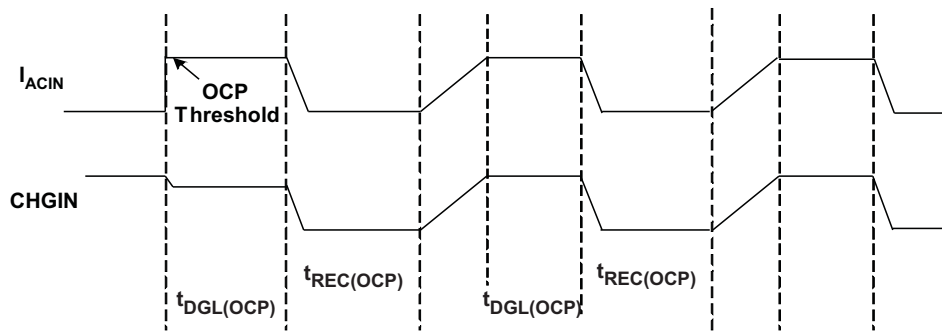

Figure 14. Charge Current OCP Timing Diagram

### Battery Over-Voltage Protection

The battery over-voltage threshold,  $BV_{OVP}$ , is internally set to 4.35V. If the battery voltage exceeds the  $BV_{OVP}$  threshold, the FET Q1 and Q2 are turned off after a deglitch time of  $t_{DGL(BOVP)}$ . The FET is turned on once the battery voltage drops to  $BV_{OVP} - V_{HYS-BOVP}$  and remains below this threshold for  $t_{REC(BOVP)}$ , as shown in Figure 15. In this battery over-voltage fault case, Q1 is switched OFF gradually for a smooth transient response.

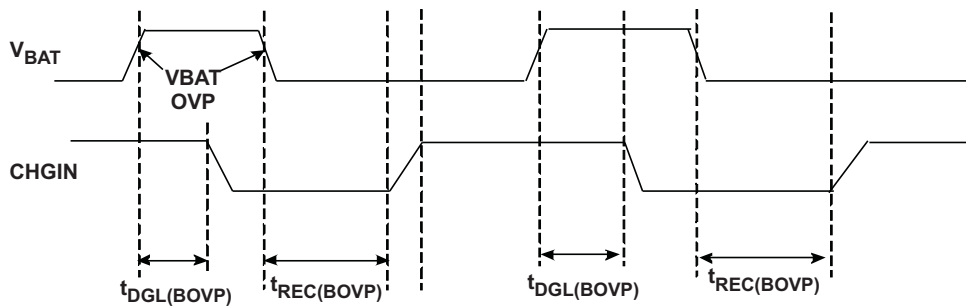

Figure 15. Battery OVP Timing Diagram

### Thermal Protection

If the junction temperature of the device exceeds  $T_{J(OFF)}$ , the FET Q1 and Q2 are turned off. The FET is turned back on when the junction temperature falls below  $T_{J(OFF)} - T_{J(OFF-HYS)}$ .

## APPLICATION INFORMATION

### Selection of $R_{BAT}$

It is strongly recommended that the battery not be tied directly to the VBAT pin of the device, as under some failure modes of the IC, the voltage at the ACIN pin may appear on the VBAT pin. This voltage can be as high as 30V, and applying 30V to the battery in case of the failure of the device can be hazardous. Connecting the VBAT pin through  $R_{BAT}$  prevents a large current from flowing into the battery in case of failure of the IC. In the interests of safety,  $R_{BAT}$  should have a very high value. The problem with a large  $R_{BAT}$  is that the voltage drop across this resistor because of the VBAT bias current  $I_{VBAT}$  causes an error in the  $BV_{OVP}$  threshold. This error is over and above the tolerance on the nominal 4.35V  $BV_{OVP}$  threshold.

Choosing  $R_{BAT}$  in the range 100k $\Omega$  to 470k $\Omega$  is a good compromise. In the case of IC failure, with  $R_{BAT}$  equal to 100k $\Omega$ , the maximum current flowing into the battery would be  $(30V - 3V) \div 100k\Omega = 270\mu A$ , which is low enough to be absorbed by the bias currents of the system components.  $R_{BAT}$  equal to 100k $\Omega$  would result in a worst-case voltage drop of  $R_{BAT} \times I_{VBAT} = 1mV$ . This is negligible compared to the internal tolerance of 50mV on the  $BV_{OVP}$  threshold.

If the Battery OVP function is not required, the VBAT pin should be connected to GND.

### Selection of Input and Output Bypass Capacitors

The input capacitor  $C_{ACIN}$  is for decoupling, and serves an important purpose. Whenever there is a step change downwards in the system load current, the inductance of the input cable causes the input voltage to spike up.  $C_{ACIN}$  prevents the input voltage from overshooting to dangerous levels. It is strongly recommended that a ceramic capacitor of at least 1 $\mu F$  be used at the input of the device. It should be located in close proximity to the ACIN pin.

$C_{CHGIN}$  should also be a ceramic capacitor of at least 1 $\mu F$ , located close to the CHGIN pin.  $C_{CHGIN}$  also serves as the input decoupling capacitor for the charging circuit downstream of the protection IC.

### PCB Layout Guidelines

1. This device is a protection device, and is meant to protect down-stream circuitry from hazardous voltages. Potentially, high voltages may be applied to this IC. It has to be ensured that the edge-to-edge clearances of PCB traces satisfy the design rules for the maximum voltages expected to be seen in the system.
2. The device uses SON packages with a PowerPAD™. For good thermal performance, the PowerPAD should be thermally coupled with the PCB ground plane. In most applications, this will require a copper pad directly under the IC. This copper pad should be connected to the ground plane with an array of thermal vias.
3.  $C_{ACIN}$  and  $C_{CHGIN}$  should be located close to the IC. Other components like  $R_{BAT}$  should also be located close to the IC.

**PACKAGING INFORMATION**

Orderable Device	Status (1)	Package Type	Package Drawing	Pins	Package Qty	Eco Plan (2)	Lead/Ball Finish	MSL Peak Temp (3)	Op Temp (°C)	Top-Side Markings (4)	Samples
BQ24350DSGR	ACTIVE	WS0N	DSG	8	3000	Green (RoHS & no Sb/Br)	CU NIPDAU	Level-2-260C-1 YEAR	-40 to 85	OAJ	<a href="#">Samples</a>
BQ24350DSGT	ACTIVE	WS0N	DSG	8	250	Green (RoHS & no Sb/Br)	CU NIPDAU	Level-2-260C-1 YEAR	-40 to 85	OAJ	<a href="#">Samples</a>
BQ24352DSGR	ACTIVE	WS0N	DSG	8	3000	Green (RoHS & no Sb/Br)	CU NIPDAU	Level-2-260C-1 YEAR	-40 to 85	OCY	<a href="#">Samples</a>
BQ24352DSGT	ACTIVE	WS0N	DSG	8	250	Green (RoHS & no Sb/Br)	CU NIPDAU	Level-2-260C-1 YEAR	-40 to 85	OCY	<a href="#">Samples</a>

(1) The marketing status values are defined as follows:

**ACTIVE:** Product device recommended for new designs.

**LIFEBUY:** TI has announced that the device will be discontinued, and a lifetime-buy period is in effect.

**NRND:** Not recommended for new designs. Device is in production to support existing customers, but TI does not recommend using this part in a new design.

**PREVIEW:** Device has been announced but is not in production. Samples may or may not be available.

**OBSELETE:** TI has discontinued the production of the device.

(2) Eco Plan - The planned eco-friendly classification: Pb-Free (RoHS), Pb-Free (RoHS Exempt), or Green (RoHS & no Sb/Br) - please check <http://www.ti.com/productcontent> for the latest availability information and additional product content details.

**TBD:** The Pb-Free/Green conversion plan has not been defined.

**Pb-Free (RoHS):** TI's terms "Lead-Free" or "Pb-Free" mean semiconductor products that are compatible with the current RoHS requirements for all 6 substances, including the requirement that lead not exceed 0.1% by weight in homogeneous materials. Where designed to be soldered at high temperatures, TI Pb-Free products are suitable for use in specified lead-free processes.

**Pb-Free (RoHS Exempt):** This component has a RoHS exemption for either 1) lead-based flip-chip solder bumps used between the die and package, or 2) lead-based die adhesive used between the die and leadframe. The component is otherwise considered Pb-Free (RoHS compatible) as defined above.

**Green (RoHS & no Sb/Br):** TI defines "Green" to mean Pb-Free (RoHS compatible), and free of Bromine (Br) and Antimony (Sb) based flame retardants (Br or Sb do not exceed 0.1% by weight in homogeneous material)

(3) MSL, Peak Temp. -- The Moisture Sensitivity Level rating according to the JEDEC industry standard classifications, and peak solder temperature.

(4) Multiple Top-Side Markings will be inside parentheses. Only one Top-Side Marking contained in parentheses and separated by a "~" will appear on a device. If a line is indented then it is a continuation of the previous line and the two combined represent the entire Top-Side Marking for that device.

**Important Information and Disclaimer:** The information provided on this page represents TI's knowledge and belief as of the date that it is provided. TI bases its knowledge and belief on information provided by third parties, and makes no representation or warranty as to the accuracy of such information. Efforts are underway to better integrate information from third parties. TI has taken and continues to take reasonable steps to provide representative and accurate information but may not have conducted destructive testing or chemical analysis on incoming materials and chemicals. TI and TI suppliers consider certain information to be proprietary, and thus CAS numbers and other limited information may not be available for release.

In no event shall TI's liability arising out of such information exceed the total purchase price of the TI part(s) at issue in this document sold by TI to Customer on an annual basis.



## TAPE AND REEL INFORMATION



### QUADRANT ASSIGNMENTS FOR PIN 1 ORIENTATION IN TAPE



\*All dimensions are nominal

Device	Package Type	Package Drawing	Pins	SPQ	Reel Diameter (mm)	Reel Width W1 (mm)	A0 (mm)	B0 (mm)	K0 (mm)	P1 (mm)	W (mm)	Pin1 Quadrant
BQ24350DSGR	WSON	DSG	8	3000	179.0	8.4	2.2	2.2	1.2	4.0	8.0	Q2
BQ24350DSGT	WSON	DSG	8	250	179.0	8.4	2.2	2.2	1.2	4.0	8.0	Q2
BQ24352DSGR	WSON	DSG	8	3000	179.0	8.4	2.2	2.2	1.2	4.0	8.0	Q2
BQ24352DSGT	WSON	DSG	8	250	179.0	8.4	2.2	2.2	1.2	4.0	8.0	Q2

**TAPE AND REEL BOX DIMENSIONS**

\*All dimensions are nominal

Device	Package Type	Package Drawing	Pins	SPQ	Length (mm)	Width (mm)	Height (mm)
BQ24350DSGR	WSON	DSG	8	3000	195.0	200.0	45.0
BQ24350DSGT	WSON	DSG	8	250	195.0	200.0	45.0
BQ24352DSGR	WSON	DSG	8	3000	195.0	200.0	45.0
BQ24352DSGT	WSON	DSG	8	250	195.0	200.0	45.0

## GENERIC PACKAGE VIEW

**DSG 8**

**WSON - 0.8 mm max height**

2 x 2, 0.5 mm pitch

PLASTIC SMALL OUTLINE - NO LEAD

This image is a representation of the package family, actual package may vary.  
Refer to the product data sheet for package details.

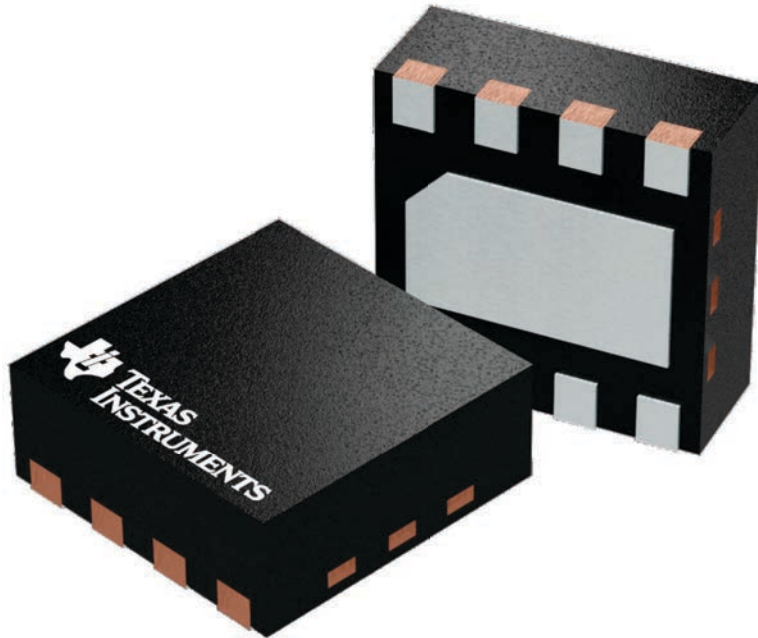

4224783/A

# DSG0008A

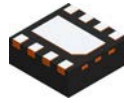

# PACKAGE OUTLINE

## WSON - 0.8 mm max height

PLASTIC SMALL OUTLINE - NO LEAD

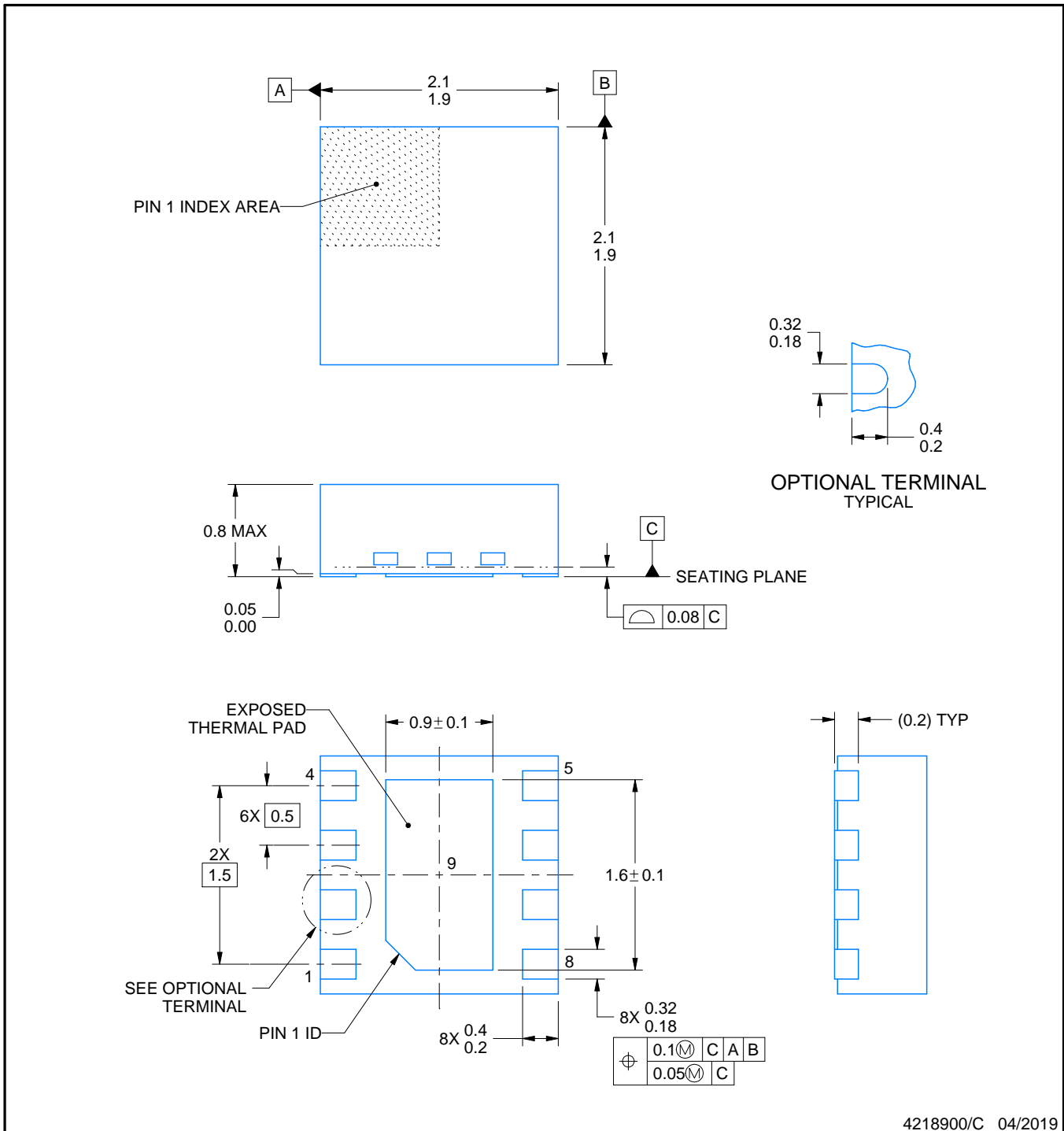

4218900/C 04/2019

### NOTES:

1. All linear dimensions are in millimeters. Any dimensions in parenthesis are for reference only. Dimensioning and tolerancing per ASME Y14.5M.
2. This drawing is subject to change without notice.
3. The package thermal pad must be soldered to the printed circuit board for thermal and mechanical performance.



# EXAMPLE STENCIL DESIGN

DSG0008A

WSON - 0.8 mm max height

PLASTIC SMALL OUTLINE - NO LEAD

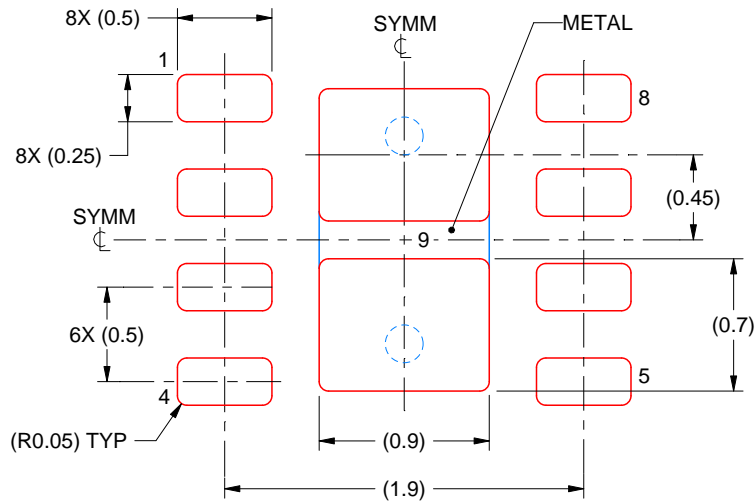

SOLDER PASTE EXAMPLE  
BASED ON 0.125 mm THICK STENCIL

EXPOSED PAD 9:  
87% PRINTED SOLDER COVERAGE BY AREA UNDER PACKAGE  
SCALE:25X

4218900/C 04/2019

NOTES: (continued)

6. Laser cutting apertures with trapezoidal walls and rounded corners may offer better paste release. IPC-7525 may have alternate design recommendations.

## IMPORTANT NOTICE AND DISCLAIMER

TI PROVIDES TECHNICAL AND RELIABILITY DATA (INCLUDING DATASHEETS), DESIGN RESOURCES (INCLUDING REFERENCE DESIGNS), APPLICATION OR OTHER DESIGN ADVICE, WEB TOOLS, SAFETY INFORMATION, AND OTHER RESOURCES "AS IS" AND WITH ALL FAULTS, AND DISCLAIMS ALL WARRANTIES, EXPRESS AND IMPLIED, INCLUDING WITHOUT LIMITATION ANY IMPLIED WARRANTIES OF MERCHANTABILITY, FITNESS FOR A PARTICULAR PURPOSE OR NON-INFRINGEMENT OF THIRD PARTY INTELLECTUAL PROPERTY RIGHTS.

These resources are intended for skilled developers designing with TI products. You are solely responsible for (1) selecting the appropriate TI products for your application, (2) designing, validating and testing your application, and (3) ensuring your application meets applicable standards, and any other safety, security, or other requirements. These resources are subject to change without notice. TI grants you permission to use these resources only for development of an application that uses the TI products described in the resource. Other reproduction and display of these resources is prohibited. No license is granted to any other TI intellectual property right or to any third party intellectual property right. TI disclaims responsibility for, and you will fully indemnify TI and its representatives against, any claims, damages, costs, losses, and liabilities arising out of your use of these resources.

TI's products are provided subject to TI's Terms of Sale ([www.ti.com/legal/termsofsale.html](http://www.ti.com/legal/termsofsale.html)) or other applicable terms available either on [ti.com](http://ti.com) or provided in conjunction with such TI products. TI's provision of these resources does not expand or otherwise alter TI's applicable warranties or warranty disclaimers for TI products.

Mailing Address: Texas Instruments, Post Office Box 655303, Dallas, Texas 75265  
Copyright © 2019, Texas Instruments Incorporated

## Looking for pricing, stock, or lifecycle information?

Click below to explore more details on WIN SOURCE:

 [View BQ24352DSGT](#) on WIN SOURCE

 [Texas Instruments](#) Information

## Optimize Your Supply Chain with WIN SOURCE Solutions

-  Global Sourcing Solution
-  Obsolete Management
-  Cost Control Management
-  Shortage Management
-  Alternative Solution
-  Excess Inventory Management