



**THE DATASHEET OF
SN65LVP20DRFT**





LVPECL AND LVDS REPEATER/TRANSLATOR WITH ENABLE

FEATURES

- Low-Voltage PECL Input and Low-Voltage PECL or LVDS Outputs
- Signaling Rates to 4 Gbps or Clock Rates to 2 GHz
 - 120-ps Output Transition Times
 - Less than 45 ps Total Jitter
 - Less than 630 ps Propagation Delay Times

- 2.5-V or 3.3-V Supply Operation
- 2-mm x 2-mm Small-Outline No-Lead Package

APPLICATIONS

- PECL-to-LVDS Translation
- Data or Clock Signal Amplification

DESCRIPTION

The SN65LVDS20 and SN65LVP20 are a high-speed differential receiver and driver connected as a repeater. The receiver accepts low-voltage positive-emitter-coupled logic (PECL) at signaling rates up to 4 Gbps and repeats it as either an LVDS or PECL output signal. The signal path through the device is differential for low radiated emissions and minimal added jitter.

The outputs of the SN65LVDS20 are LVDS levels as defined by TIA/EIA-644-A. The outputs of the SN65LVDP20 are compatible with low-voltage PECL levels. A low-level input to \overline{EN} enables the outputs. A high-level input puts the output into a high-impedance state. Both outputs are designed to drive differential transmission lines with nominally 100- Ω characteristic impedance.

Both devices provide a voltage reference (V_{BB}) of typically 1.35 V below V_{CC} for use in receiving single-ended PECL input signals. When not used, V_{BB} should be unconnected or open.

All devices are characterized for operation from -40°C to 85°C.

FUNCTION DIAGRAM

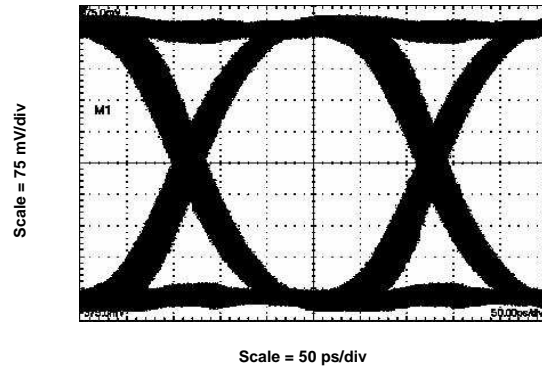
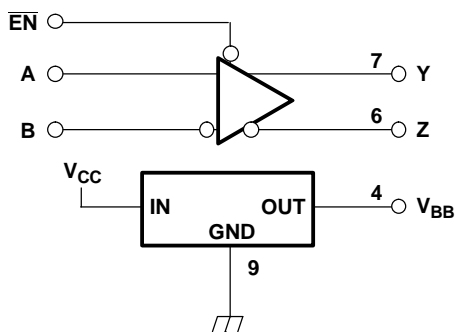

Figure 1. SN65LVDS20 Output Eye Pattern With 4-Gbps PRBS Input



Please be aware that an important notice concerning availability, standard warranty, and use in critical applications of Texas Instruments semiconductor products and disclaimers thereto appears at the end of this data sheet.



These devices have limited built-in ESD protection. The leads should be shorted together or the device placed in conductive foam during storage or handling to prevent electrostatic damage to the MOS gates.

AVAILABLE OPTIONS⁽¹⁾

INPUT	OUTPUT	PART NUMBER	PART MARKING
Differential	LVDS	SN65LVDS20	E8
Differential	LVPECL	SN65LVP20	E7

(1) For the most current package and ordering information, see the Package Option Addendum at the end of this document, or see the TI website at www.ti.com.

ABSOLUTE MAXIMUM RATINGS

over operating free-air temperature range (unless otherwise noted) ⁽¹⁾

	UNIT
V _{CC} Supply voltage ⁽²⁾	-0.5 V to 4 V
V _I Input voltage	-0.5 V to V _{CC} + 0.5 V
V _O Output voltage	-0.5 V to V _{CC} + 0.5 V
I _O V _{BB} output current	±0.5 mA
HBM electrostatic discharge ⁽³⁾	±3 kV
CDM electrostatic discharge ⁽⁴⁾	±1500 V
Continuous power dissipation	See Power Dissipation Ratings Table

- (1) Stresses beyond those listed under "absolute maximum ratings" may cause permanent damage to the device. These are stress ratings only and functional operation of the device at these or any other conditions beyond those indicated under "recommended operating conditions" is not implied. Exposure to absolute-maximum-rated conditions for extended periods may affect device reliability.
- (2) All voltage values, except differential voltages, are with respect to network ground (see [Figure 2](#)).
- (3) Tested in accordance with JEDEC Standard 22, Test Method A114-A-7
- (4) Tested in accordance with JEDEC Standard 22, Test Method C101

DISSIPATION RATINGS

PACKAGE	T _A < 25°C POWER RATING	OPERATING FACTOR ABOVE T _A = 25°C	T _A = 85°C POWER RATING
DRF	403 mW	4.0 mW/°C	161 mW

RECOMMENDED OPERATING CONDITIONS

	MIN	NOM	MAX	UNIT
V _{CC} Supply Voltage	2.375	2.5 or 3.3	3.6	V
V _{IC} Common-mode input voltage (V _{IA} + V _{IB})/2	1.2		V _{CC} - (V _{ID} /2)	V
V _{ID} Differential input voltage magnitude, V _{IA} - V _{IB}	0.08		1	V
V _{IH} High-level input voltage, \overline{EN}	2		V _{CC}	V
V _{IL} Low-level input voltage, \overline{EN}	0		0.8	V
I _O Output current to V _{BB}	-400 ⁽¹⁾		400	μA
R _L Differential load resistance	90		132	Ω
T _A Operating free-air temperature	-40		85	°C

(1) The algebraic convention, where the least positive (more negative) value is designated minimum, is used in this data sheet.

ELECTRICAL CHARACTERISTICS

over recommended operating conditions (unless otherwise noted)

PARAMETER		TEST CONDITIONS	MIN	TYP ⁽¹⁾	MAX	UNIT
I _{CC}	Supply current	R _L = 100 Ω, $\overline{\text{EN}}$ at 0 V, Other inputs open		35	45	mA
		Outputs unloaded, $\overline{\text{EN}}$ at 0 V, Other inputs open		19	24	
P _D	Device power dissipation, SN65LVDS20	R _L = 100 Ω, $\overline{\text{EN}}$ at 0 V, 2-GHz 50%-duty-cycle square-wave input		116	160	mW
	Device power dissipation, SN65LVP20	50 Ω from Y and Z to V _{CC} - 2 V, $\overline{\text{EN}}$ at 0 V, 2-GHz 50%-duty-cycle square-wave input		63	86	
V _{BB}	Reference voltage	I _{BB} = ±400 μA	V _{CC} - 1.44	V _{CC} - 1.35	V _{CC} - 1.25	V
I _{IH}	High-level input current, $\overline{\text{EN}}$	V _I = 2 V	-20		20	μA
I _{IAH} or I _{IBH}	High-level input current, A or B	V _I = V _{CC}	-20		20	
I _{IL}	Low-level input current, $\overline{\text{EN}}$	V _I = 0.8 V	-20		20	
I _{IAL} or I _{IBL}	Low-level input current, A or B	V _I = GND	-20		20	
SN65LVDS20 OUTPUT CHARACTERISTICS (see Figure 2)						
V _{OD}	Differential output voltage magnitude, V _{OY} - V _{OZ}	See Figure 2	247	340	454	mV
Δ V _{OD}	Change in differential output voltage magnitude between logic states		50			
V _{OC(SS)}	Steady-state common-mode output voltage (see Figure 3)		1.125		1.375	V
ΔV _{OC(SS)}	Change in steady-state com- mon-mode output voltage between logic states	See Figure 3	-50		50	mV
V _{OC(PP)}	Peak-to-peak common-mode output voltage		50		100	
I _{OYZ} or I _{OZZ}	High-impedance output current	$\overline{\text{EN}}$ at V _{CC} , V _O = 0 V or V _{CC}	-1		1	μA
I _{OYS} or I _{OZS}	Short-circuit output current	$\overline{\text{EN}}$ at 0 V, V _{OY} or V _{OZ} = 0 V	-62		62	mA
I _{OS(D)}	Differential short-circuit output cur- rent, I _{OY} - I _{OZ}	$\overline{\text{EN}}$ at 0 V, V _{OY} = V _{OZ}	-12		12	
SN65LVP20 OUTPUT CHARACTERISTICS (see Figure 2)						
V _{OYH} or V _{OZH}	High-level output voltage	3.3 V; 50 Ω from Y and Z to V _{CC} - 2 V	V _{CC} - 1.05		V _{CC} - 0.82	V
V _{OYL} or V _{OZL}	Low-level output voltage		V _{CC} - 1.83		V _{CC} - 1.57	
V _{OYL} or V _{OZL}	Low-level output voltage		2.5 V; 50 Ω from Y and Z to V _{CC} - 2 V	V _{CC} - 1.88		
V _{OD}	Differential output voltage magnitude, V _{OH} - V _{OL}		0.6	0.8	1	
I _{OYZ} or I _{OZZ}	High-impedance output current	$\overline{\text{EN}}$ at V _{CC} , V _O = 0 V or V _{CC}	-1		1	μA

(1) Typical values are at room temperature and with a V_{CC} of 3.3 V.

SWITCHING CHARACTERISTICS

over recommended operating conditions (unless otherwise noted)

PARAMETER		TEST CONDITIONS	MIN	TYP ⁽¹⁾	MAX	UNIT
t_{PLH}	Differential propagation delay time, low-to-high-level output	See Figure 2 and Figure 4	300	450	630	ps
t_{PHL}	Differential propagation delay time, high-level-to-low-level output		300	450	630	
$t_{SK(P)}$	Pulse skew, $ t_{PLH} - t_{PHL} $				20	
$t_{SK(PP)}$	Part-to-part skew ⁽²⁾	$V_{CC} = 3.3\text{ V}$			80	ps
		$V_{CC} = 2.5\text{ V}$			130	
t_r	20%-to-80% differential signal rise time	LVDS, See Figure 2 and Figure 4		85	115	ps
		LVPECL, See Figure 2 and Figure 4		92	120	
t_f	20%-to-80% differential signal fall time	LVDS, See Figure 2 and Figure 4		85	115	ps
		LVPECL, See Figure 2 and Figure 4		92	120	
$t_{jit(per)}$	RMS period jitter ⁽³⁾	2-GHz 50%-duty-cycle square-wave input, See Figure 5		2	3	ps
$t_{jit(cc)}$	Peak cycle-to-cycle jitter ⁽⁴⁾			13	16	
$t_{jit(p-p)}$	Peak-to-peak jitter	LVDS; 4 Gbps PRBS, 2 ²³ - 1 run length, See Figure 5		37	45	ps
$t_{jit(ph)}$	Intrinsic phase jitter	155.52 MHz		0.62		ps
		622.08 MHz		0.14		
t_{PHZ}	Propagation delay time, high-level-to-high-impedance output	See Figure 2 and Figure 6			30	ns
t_{PLZ}	Propagation delay time, low-level-to-high-impedance output				30	
t_{PZH}	Propagation delay time, high-impedance-to-high-level output				30	
t_{PZL}	Propagation delay time, high-impedance-to-low-level output				30	

- (1) Typical values are at room temperature and with a V_{CC} of 3.3 V.
- (2) Part-to-part skew is the magnitude of the difference in propagation delay times between any specified terminals of two devices when both devices operate with the same supply voltages, at the same temperature, and have identical packages and test circuits.
- (3) Period jitter is the deviation in cycle time of a signal with respect to the ideal period over a random sample of 100,000 cycles.
- (4) Cycle-to-cycle jitter is the variation in cycle time of a signal between adjacent cycles, over a random sample of 1,000 adjacent cycle pairs.

PARAMETER MEASUREMENT INFORMATION

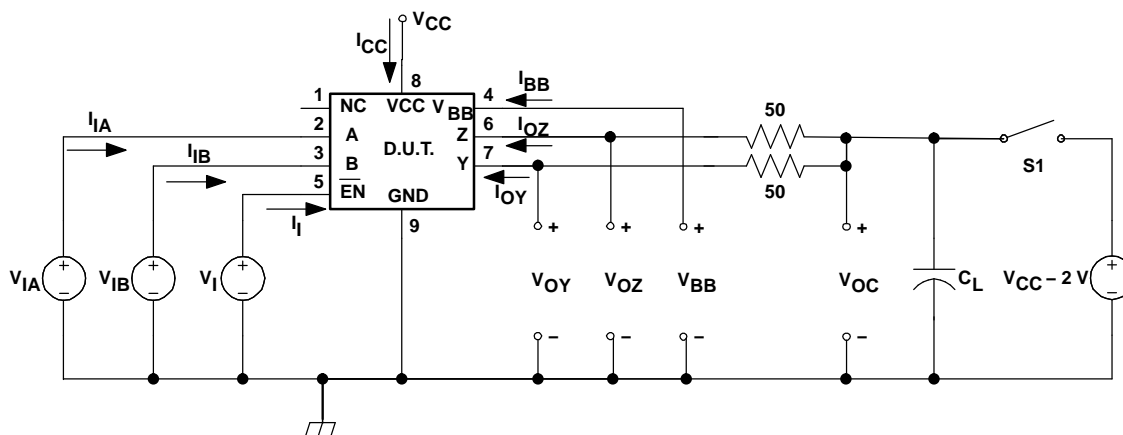

- (1) C_L is the instrumentation and test fixture capacitance.
- (2) S1 is open for the SN65LVDS20 and closed for the SN65LVP20.

Figure 2. Output Voltage Test Circuit and Voltage and Current Definitions

PARAMETER MEASUREMENT INFORMATION (continued)

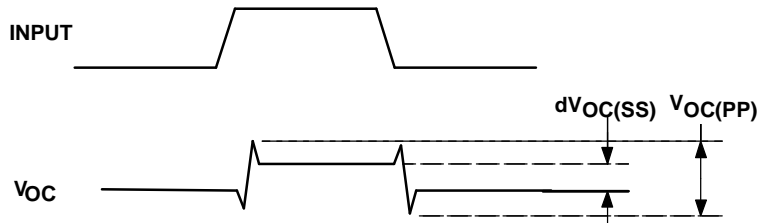

Figure 3. V_{OC} Definitions

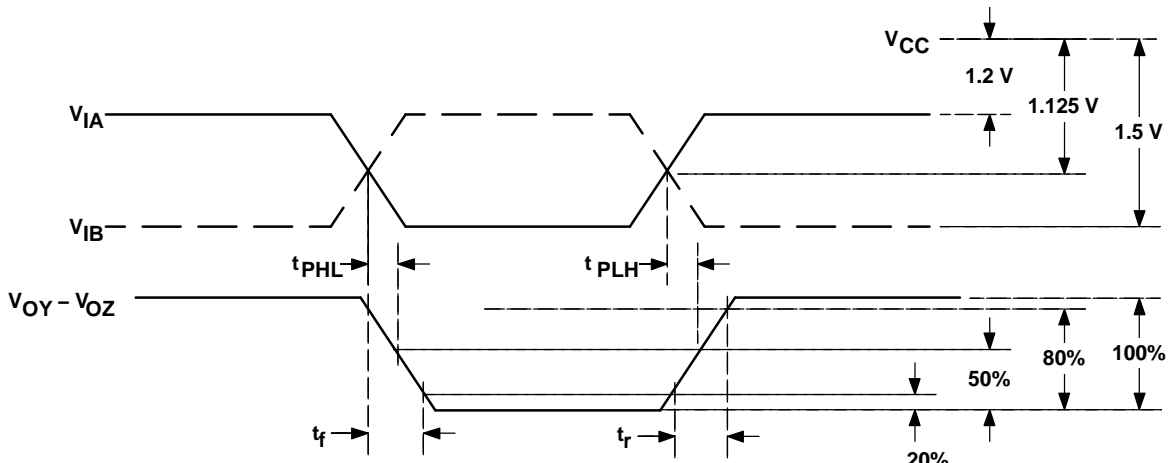

Figure 4. Propagation Delay and Transition Time Test Waveforms

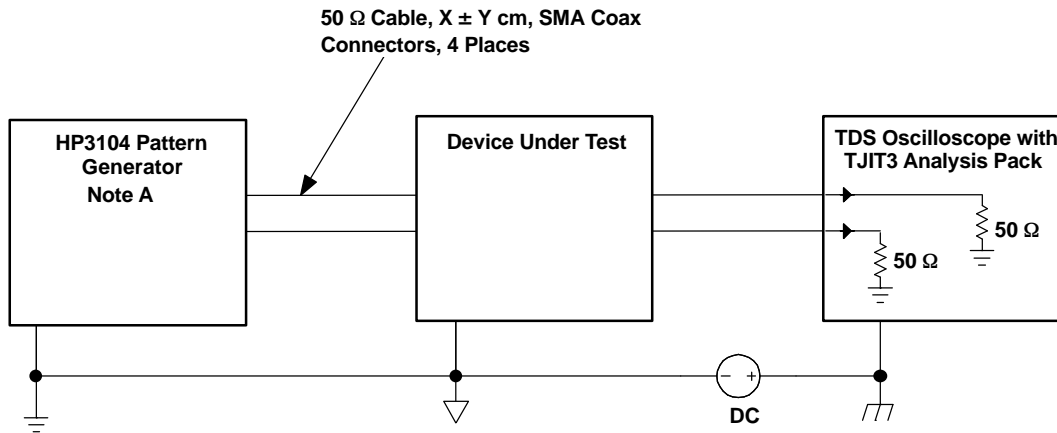

Figure 5. Jitter Measurement Setup

PARAMETER MEASUREMENT INFORMATION (continued)

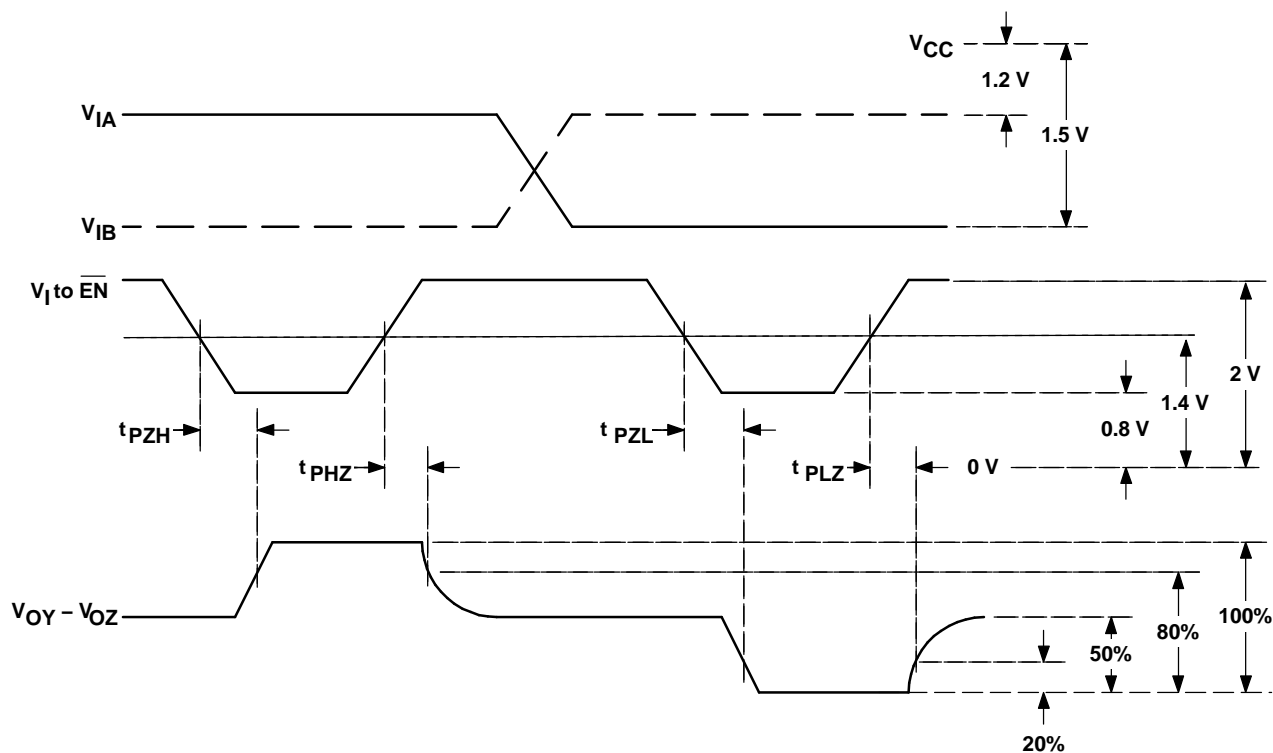

Figure 6. Enable and Disable Time Test Waveforms

DEVICE INFORMATION

FUNCTION TABLE⁽¹⁾

A	B	\overline{EN}	Y	Z
H	H	L	?	?
L	H	L	L	H
H	L	L	H	L
L	L	L	?	?
X	X	H	Z	Z
Open	Open	L	?	?
X	X	Open	?	?

(1) H = high, L = low, Z = high impedance, ? = indeterminate

TOP VIEW

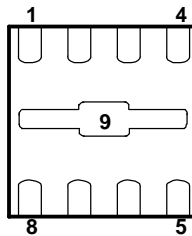
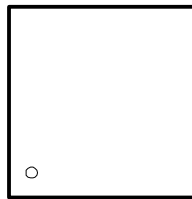

BOTTOM VIEW

Package Pin Assignments - Numerical Listing

PIN	SIGNAL	PIN	SIGNAL
1	NC	6	Z
2	A	7	Y
3	B	8	V _{CC}
4	V _{BB}	9	GND
5	$\overline{\text{EN}}$		

Package Pin Assignments - Alphabetical Listing

SIGNAL	PIN	SIGNAL	PIN
A	2	V _{BB}	4
B	3	V _{CC}	8
$\overline{\text{EN}}$	5	Y	7
GND	9	Z	6
NC	1		

TYPICAL CHARACTERISTICS

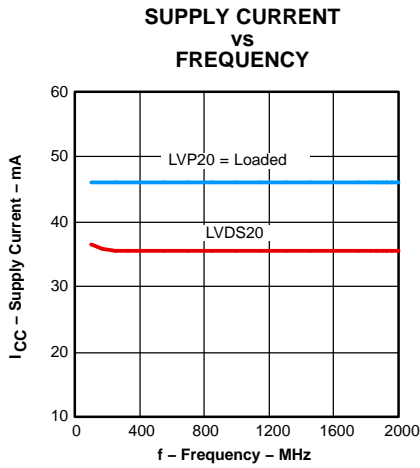

Figure 7.

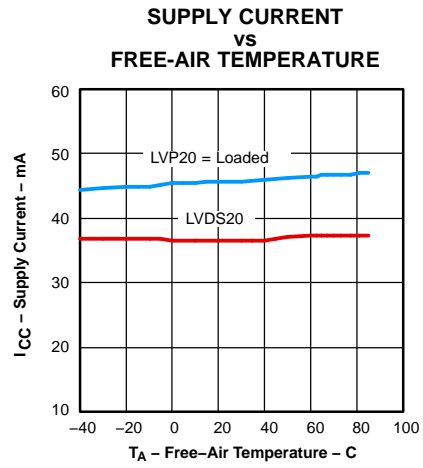

Figure 8.

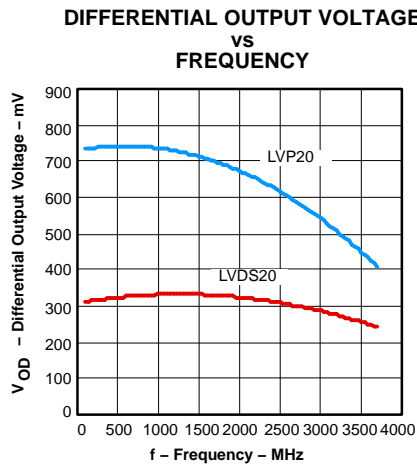

Figure 9.

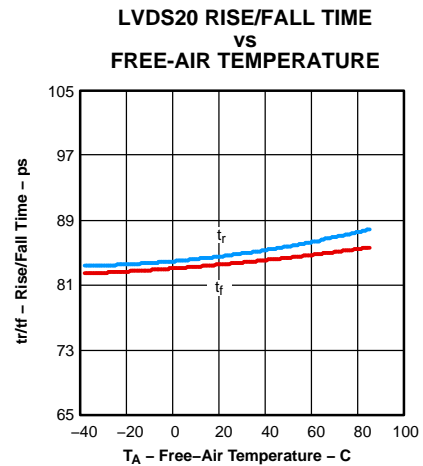

Figure 10.

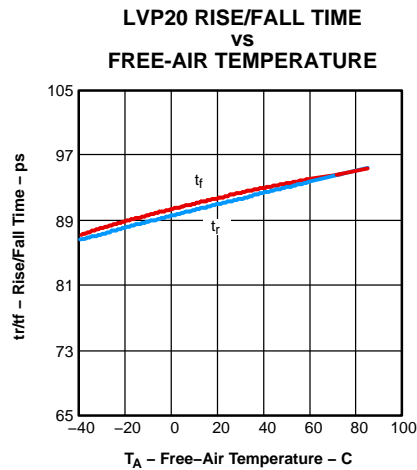

Figure 11.

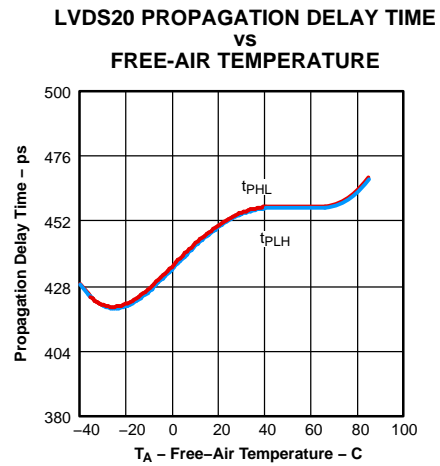

Figure 12.

TYPICAL CHARACTERISTICS (continued)

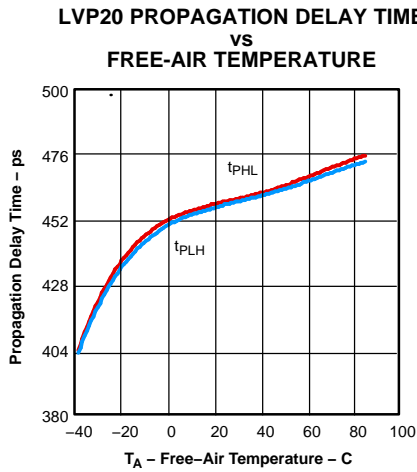

Figure 13.

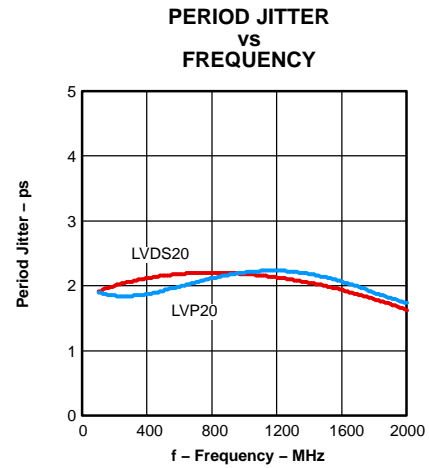

Figure 14.

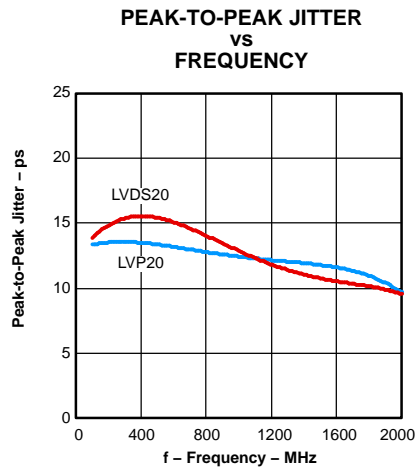

Figure 15.

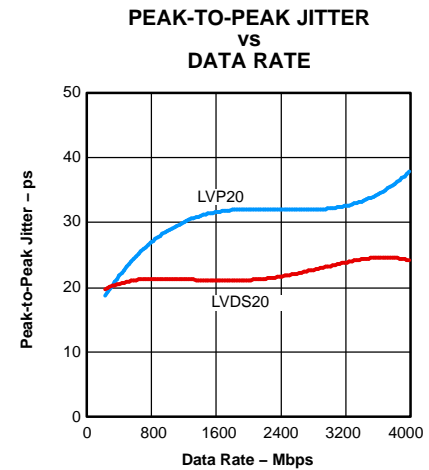

Figure 16.

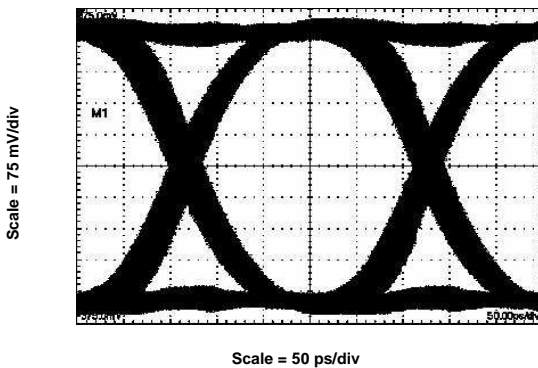

Figure 17. LVDS20 4-Gbps, $2^{23} - 1$ PRBS

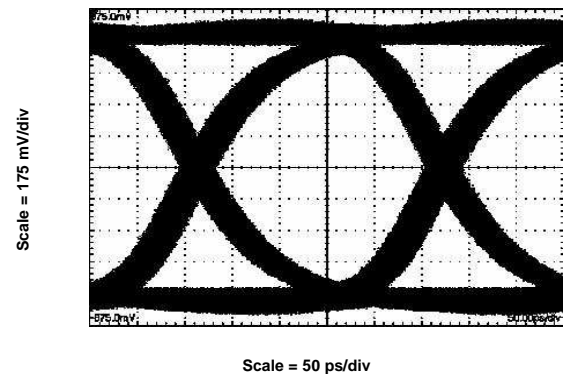

Figure 18. LVP20 4-Gbps, $2^{23} - 1$ PRBS

TYPICAL CHARACTERISTICS (continued)

PHASE NOISE OF SN65LVP20

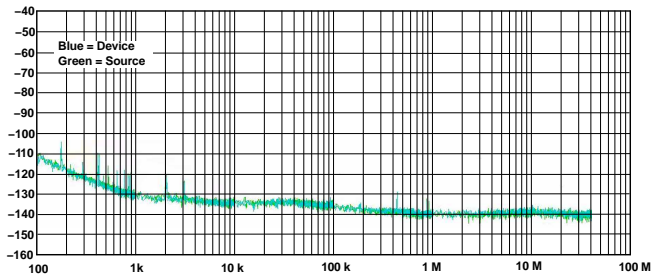

Figure 19. Frequency Offset From 155.52 MHz Carrier

PHASE NOISE OF SN65LVP20

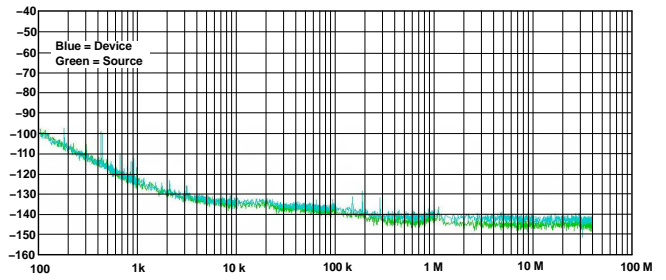
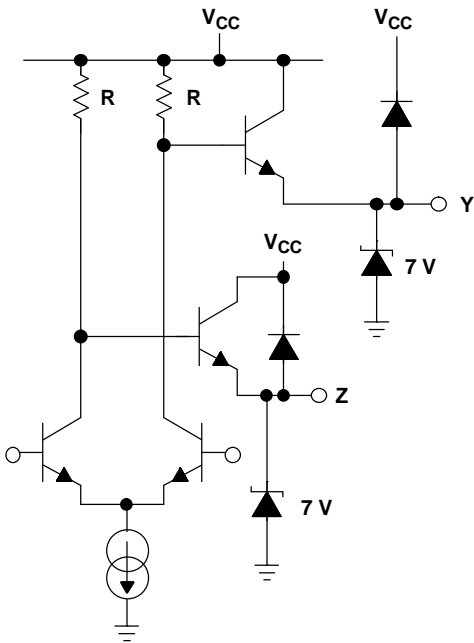

Figure 20. Frequency Offset From 622.08 MHz Carrier

EQUIVALENT INPUT AND OUTPUT SCHEMATIC DIAGRAMS

OUTPUT LVP20



OUTPUT LVDS20

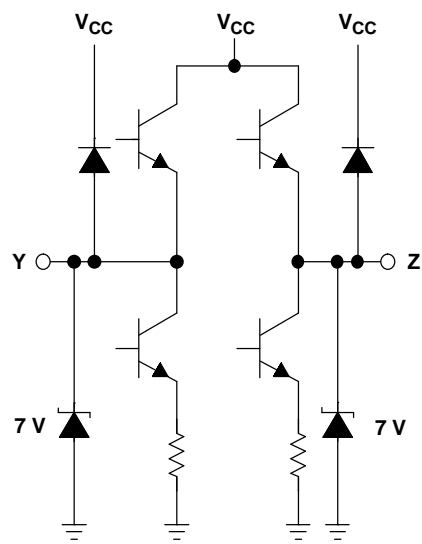

ENABLE

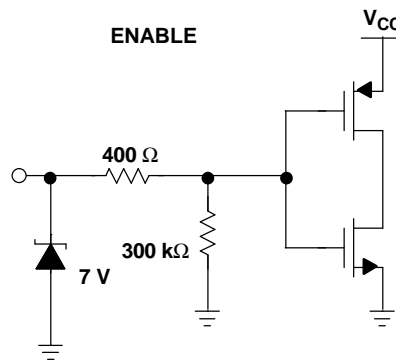

INPUT

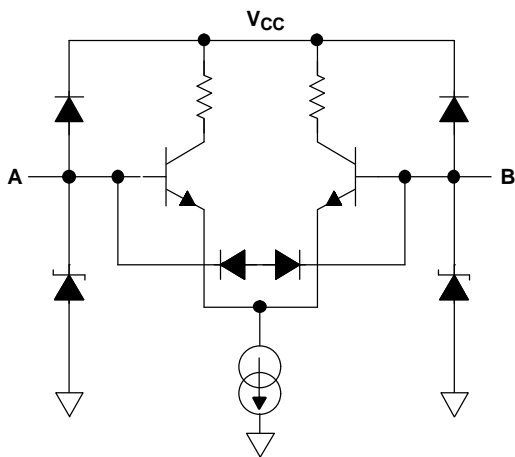

OUTPUT

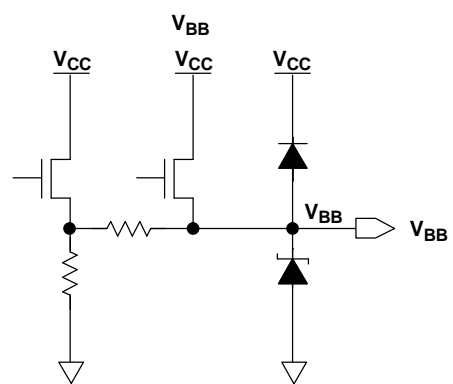

PACKAGING INFORMATION

Orderable Device	Status (1)	Package Type	Package Drawing	Pins	Package Qty	Eco Plan (2)	Lead/Ball Finish (6)	MSL Peak Temp (3)	Op Temp (°C)	Device Marking (4/5)	Samples
SN65LVDS20DRFR	ACTIVE	WSO	DRF	8	3000	Green (RoHS & no Sb/Br)	CU NIPDAU	Level-1-260C-UNLIM	-40 to 85	E8	Samples
SN65LVDS20DRFRG4	ACTIVE	WSO	DRF	8	3000	Green (RoHS & no Sb/Br)	CU NIPDAU	Level-1-260C-UNLIM	-40 to 85	E8	Samples
SN65LVDS20DRFT	ACTIVE	WSO	DRF	8	250	Green (RoHS & no Sb/Br)	CU NIPDAU	Level-1-260C-UNLIM	-40 to 85	E8	Samples
SN65LVDS20DRFTG4	ACTIVE	WSO	DRF	8	250	Green (RoHS & no Sb/Br)	CU NIPDAU	Level-1-260C-UNLIM	-40 to 85	E8	Samples
SN65LVP20DRFR	ACTIVE	WSO	DRF	8	3000	Green (RoHS & no Sb/Br)	CU NIPDAU	Level-1-260C-UNLIM	-40 to 85	E7	Samples
SN65LVP20DRFT	ACTIVE	WSO	DRF	8	250	Green (RoHS & no Sb/Br)	CU NIPDAU	Level-1-260C-UNLIM	-40 to 85	E7	Samples

(1) The marketing status values are defined as follows:

ACTIVE: Product device recommended for new designs.

LIFEBUY: TI has announced that the device will be discontinued, and a lifetime-buy period is in effect.

NRND: Not recommended for new designs. Device is in production to support existing customers, but TI does not recommend using this part in a new design.

PREVIEW: Device has been announced but is not in production. Samples may or may not be available.

OBSELETE: TI has discontinued the production of the device.

(2) Eco Plan - The planned eco-friendly classification: Pb-Free (RoHS), Pb-Free (RoHS Exempt), or Green (RoHS & no Sb/Br) - please check <http://www.ti.com/productcontent> for the latest availability information and additional product content details.

TBD: The Pb-Free/Green conversion plan has not been defined.

Pb-Free (RoHS): TI's terms "Lead-Free" or "Pb-Free" mean semiconductor products that are compatible with the current RoHS requirements for all 6 substances, including the requirement that lead not exceed 0.1% by weight in homogeneous materials. Where designed to be soldered at high temperatures, TI Pb-Free products are suitable for use in specified lead-free processes.

Pb-Free (RoHS Exempt): This component has a RoHS exemption for either 1) lead-based flip-chip solder bumps used between the die and package, or 2) lead-based die adhesive used between the die and leadframe. The component is otherwise considered Pb-Free (RoHS compatible) as defined above.

Green (RoHS & no Sb/Br): TI defines "Green" to mean Pb-Free (RoHS compatible), and free of Bromine (Br) and Antimony (Sb) based flame retardants (Br or Sb do not exceed 0.1% by weight in homogeneous material)

(3) MSL, Peak Temp. - The Moisture Sensitivity Level rating according to the JEDEC industry standard classifications, and peak solder temperature.

(4) There may be additional marking, which relates to the logo, the lot trace code information, or the environmental category on the device.

(5) Multiple Device Markings will be inside parentheses. Only one Device Marking contained in parentheses and separated by a "~" will appear on a device. If a line is indented then it is a continuation of the previous line and the two combined represent the entire Device Marking for that device.

⁽⁶⁾ Lead/Ball Finish - Orderable Devices may have multiple material finish options. Finish options are separated by a vertical ruled line. Lead/Ball Finish values may wrap to two lines if the finish value exceeds the maximum column width.

Important Information and Disclaimer: The information provided on this page represents TI's knowledge and belief as of the date that it is provided. TI bases its knowledge and belief on information provided by third parties, and makes no representation or warranty as to the accuracy of such information. Efforts are underway to better integrate information from third parties. TI has taken and continues to take reasonable steps to provide representative and accurate information but may not have conducted destructive testing or chemical analysis on incoming materials and chemicals. TI and TI suppliers consider certain information to be proprietary, and thus CAS numbers and other limited information may not be available for release.

In no event shall TI's liability arising out of such information exceed the total purchase price of the TI part(s) at issue in this document sold by TI to Customer on an annual basis.

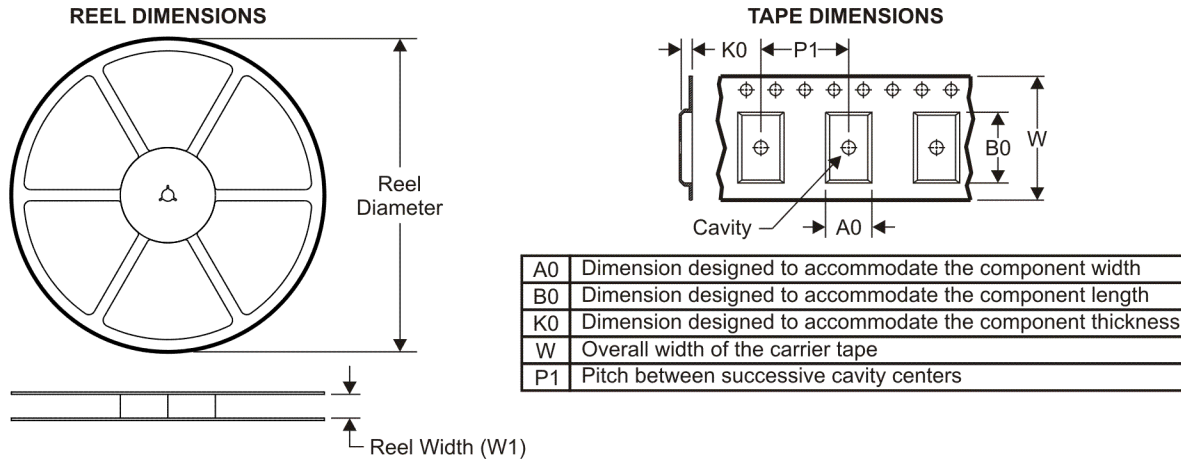
TAPE AND REEL INFORMATION

QUADRANT ASSIGNMENTS FOR PIN 1 ORIENTATION IN TAPE

*All dimensions are nominal

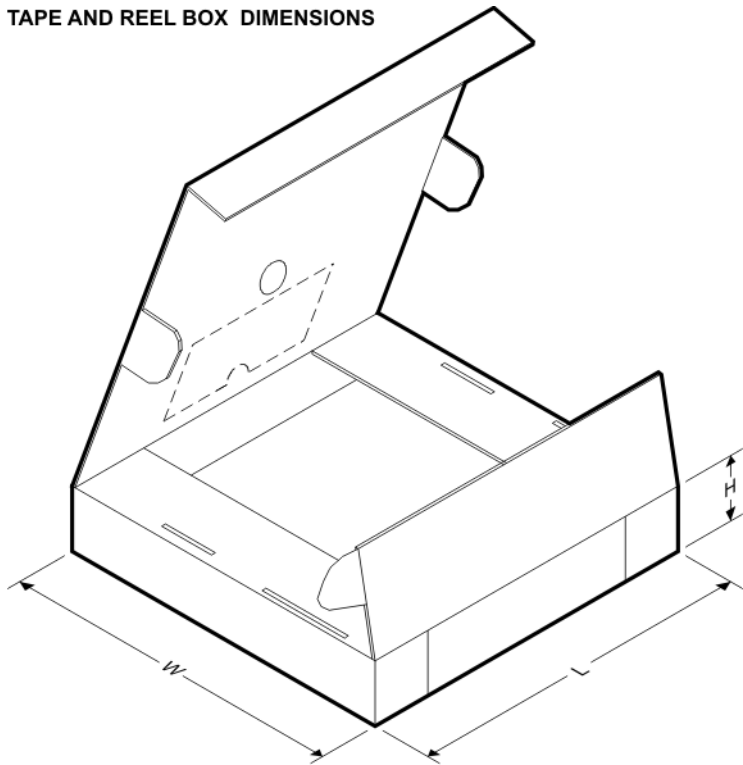
Device	Package Type	Package Drawing	Pins	SPQ	Reel Diameter (mm)	Reel Width W1 (mm)	A0 (mm)	B0 (mm)	K0 (mm)	P1 (mm)	W (mm)	Pin1 Quadrant
SN65LVDS20DRFR	WSON	DRF	8	3000	330.0	8.8	2.3	2.3	1.0	4.0	8.0	Q2
SN65LVDS20DRFT	WSON	DRF	8	250	330.0	8.8	2.3	2.3	1.0	4.0	8.0	Q2
SN65LVP20DRFR	WSON	DRF	8	3000	330.0	8.8	2.3	2.3	1.0	4.0	8.0	Q2
SN65LVP20DRFT	WSON	DRF	8	250	330.0	8.8	2.3	2.3	1.0	4.0	8.0	Q2

TAPE AND REEL BOX DIMENSIONS

*All dimensions are nominal

Device	Package Type	Package Drawing	Pins	SPQ	Length (mm)	Width (mm)	Height (mm)
SN65LVDS20DRFR	WSON	DRF	8	3000	337.0	343.0	29.0
SN65LVDS20DRFT	WSON	DRF	8	250	337.0	343.0	29.0
SN65LVP20DRFR	WSON	DRF	8	3000	337.0	343.0	29.0
SN65LVP20DRFT	WSON	DRF	8	250	337.0	343.0	29.0

DRF (S-PWSON-N8)

PLASTIC SMALL OUTLINE NO-LEAD

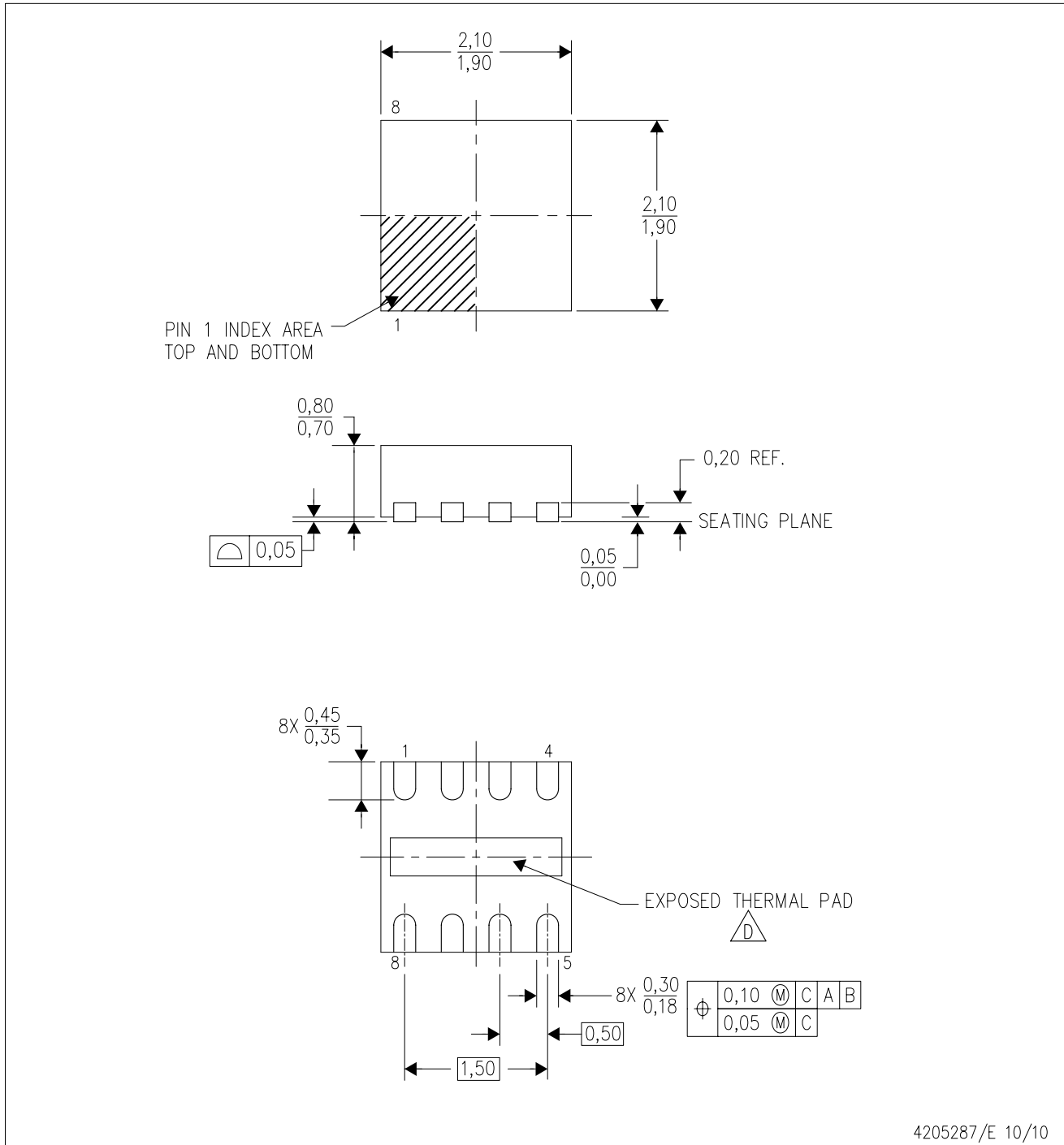

- NOTES:
- A. All linear dimensions are in millimeters. Dimensioning and tolerancing per ASME Y14.5M-1994.
 - B. This drawing is subject to change without notice.
 - C. Quad Flatpack, No-Leads (QFN) package configuration.
 - D. The Package thermal pad must be soldered to the board for thermal and mechanical performance. See product data sheet for details regarding the exposed thermal pad dimensions.
 - E. Falls within JEDEC MO-229.

THERMAL PAD MECHANICAL DATA

DRF (S-PWSON-N8)

PLASTIC SMALL OUTLINE NO-LEAD

THERMAL INFORMATION

This package incorporates an exposed thermal pad that is designed to be attached directly to an external heatsink. The thermal pad must be soldered directly to the printed circuit board (PCB). After soldering, the PCB can be used as a heatsink. In addition, through the use of thermal vias, the thermal pad can be attached directly to the appropriate copper plane shown in the electrical schematic for the device, or alternatively, can be attached to a special heatsink structure designed into the PCB. This design optimizes the heat transfer from the integrated circuit (IC).

For information on the Quad Flatpack No-Lead (QFN) package and its advantages, refer to Application Report, QFN/SOIC PCB Attachment, Texas Instruments Literature No. SLUA271. This document is available at www.ti.com.

The exposed thermal pad dimensions for this package are shown in the following illustration.

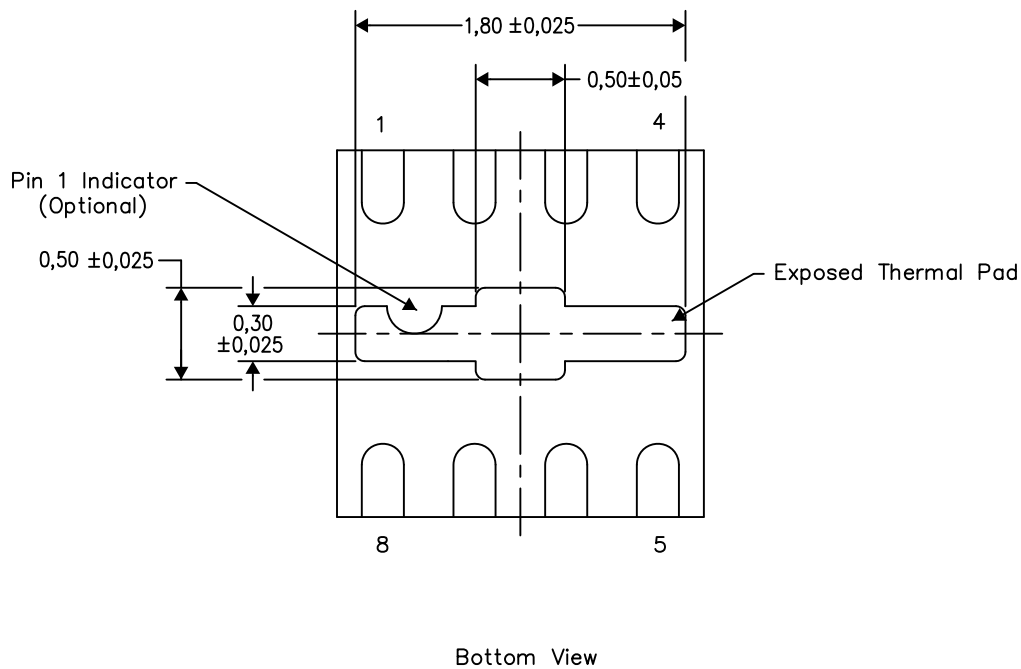

Exposed Thermal Pad Dimensions

4206840/H 12/14

NOTE: A. All linear dimensions are in millimeters

DRF (S-PWSON-N8)

PLASTIC SMALL OUTLINE NO-LEAD

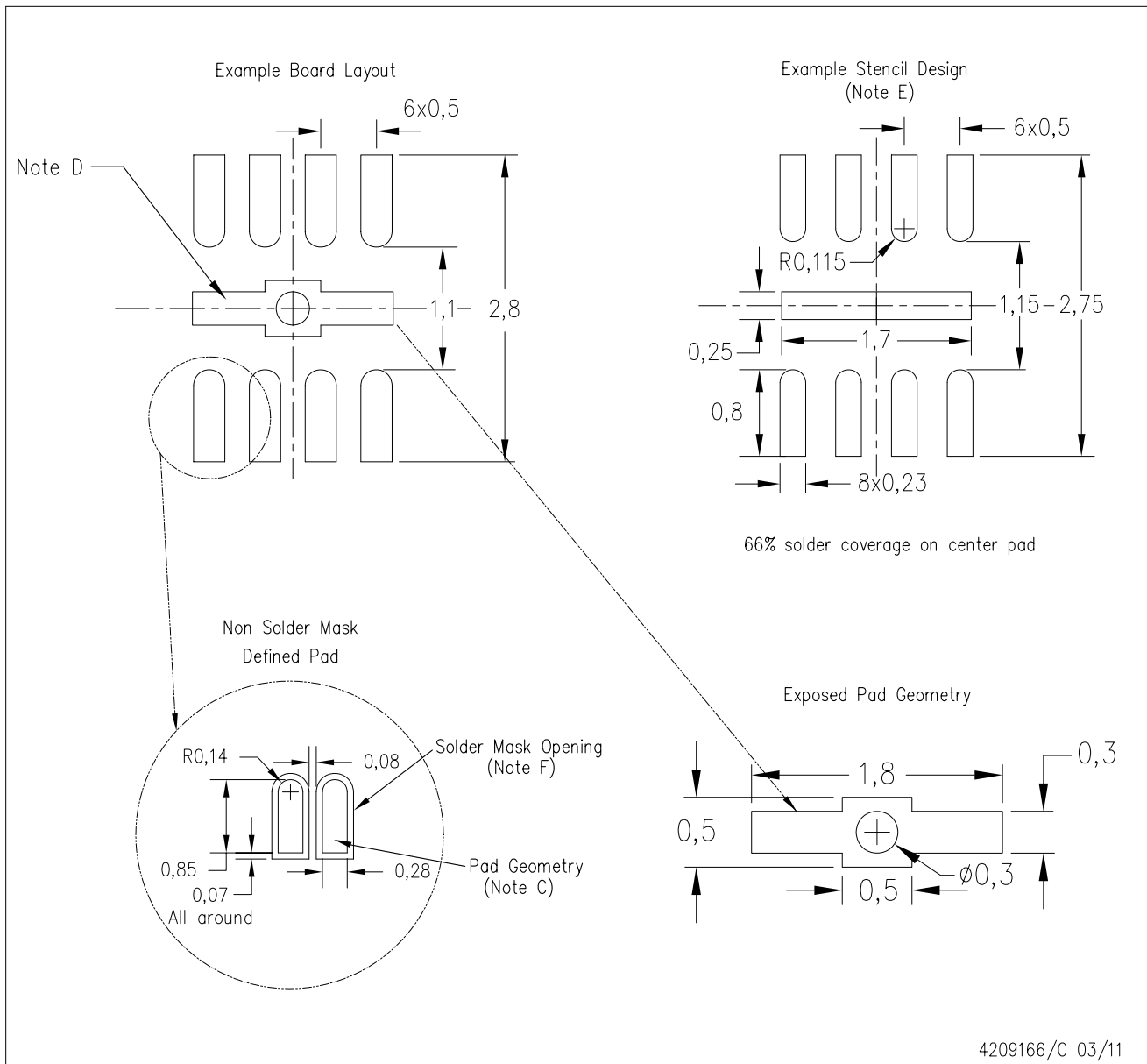

- NOTES:
- All linear dimensions are in millimeters.
 - This drawing is subject to change without notice.
 - Publication IPC-7351 is recommended for alternate designs.
 - This package is designed to be soldered to a thermal pad on the board. Refer to Application Note, Quad Flat-Pack Packages, Texas Instruments Literature No. SLUA271, and also the Product Data Sheets for specific thermal information, via requirements, and recommended board layout. These documents are available at www.ti.com <<http://www.ti.com>>.
 - Laser cutting apertures with trapezoidal walls and also rounding corners will offer better paste release. Customers should contact their board assembly site for stencil design recommendations. Refer to IPC 7525 for stencil design considerations.
 - Customers should contact their board fabrication site for minimum solder mask web tolerances between signal pads.

IMPORTANT NOTICE

Texas Instruments Incorporated and its subsidiaries (TI) reserve the right to make corrections, enhancements, improvements and other changes to its semiconductor products and services per JESD46, latest issue, and to discontinue any product or service per JESD48, latest issue. Buyers should obtain the latest relevant information before placing orders and should verify that such information is current and complete. All semiconductor products (also referred to herein as "components") are sold subject to TI's terms and conditions of sale supplied at the time of order acknowledgment.

TI warrants performance of its components to the specifications applicable at the time of sale, in accordance with the warranty in TI's terms and conditions of sale of semiconductor products. Testing and other quality control techniques are used to the extent TI deems necessary to support this warranty. Except where mandated by applicable law, testing of all parameters of each component is not necessarily performed.

TI assumes no liability for applications assistance or the design of Buyers' products. Buyers are responsible for their products and applications using TI components. To minimize the risks associated with Buyers' products and applications, Buyers should provide adequate design and operating safeguards.

TI does not warrant or represent that any license, either express or implied, is granted under any patent right, copyright, mask work right, or other intellectual property right relating to any combination, machine, or process in which TI components or services are used. Information published by TI regarding third-party products or services does not constitute a license to use such products or services or a warranty or endorsement thereof. Use of such information may require a license from a third party under the patents or other intellectual property of the third party, or a license from TI under the patents or other intellectual property of TI.

Reproduction of significant portions of TI information in TI data books or data sheets is permissible only if reproduction is without alteration and is accompanied by all associated warranties, conditions, limitations, and notices. TI is not responsible or liable for such altered documentation. Information of third parties may be subject to additional restrictions.

Resale of TI components or services with statements different from or beyond the parameters stated by TI for that component or service voids all express and any implied warranties for the associated TI component or service and is an unfair and deceptive business practice. TI is not responsible or liable for any such statements.

Buyer acknowledges and agrees that it is solely responsible for compliance with all legal, regulatory and safety-related requirements concerning its products, and any use of TI components in its applications, notwithstanding any applications-related information or support that may be provided by TI. Buyer represents and agrees that it has all the necessary expertise to create and implement safeguards which anticipate dangerous consequences of failures, monitor failures and their consequences, lessen the likelihood of failures that might cause harm and take appropriate remedial actions. Buyer will fully indemnify TI and its representatives against any damages arising out of the use of any TI components in safety-critical applications.

In some cases, TI components may be promoted specifically to facilitate safety-related applications. With such components, TI's goal is to help enable customers to design and create their own end-product solutions that meet applicable functional safety standards and requirements. Nonetheless, such components are subject to these terms.

No TI components are authorized for use in FDA Class III (or similar life-critical medical equipment) unless authorized officers of the parties have executed a special agreement specifically governing such use.

Only those TI components which TI has specifically designated as military grade or "enhanced plastic" are designed and intended for use in military/aerospace applications or environments. Buyer acknowledges and agrees that any military or aerospace use of TI components which have **not** been so designated is solely at the Buyer's risk, and that Buyer is solely responsible for compliance with all legal and regulatory requirements in connection with such use.

TI has specifically designated certain components as meeting ISO/TS16949 requirements, mainly for automotive use. In any case of use of non-designated products, TI will not be responsible for any failure to meet ISO/TS16949.

Products

Audio	www.ti.com/audio
Amplifiers	amplifier.ti.com
Data Converters	dataconverter.ti.com
DLP® Products	www.dlp.com
DSP	dsp.ti.com
Clocks and Timers	www.ti.com/clocks
Interface	interface.ti.com
Logic	logic.ti.com
Power Mgmt	power.ti.com
Microcontrollers	microcontroller.ti.com
RFID	www.ti-rfid.com
OMAP Applications Processors	www.ti.com/omap
Wireless Connectivity	www.ti.com/wirelessconnectivity

Applications

Automotive and Transportation	www.ti.com/automotive
Communications and Telecom	www.ti.com/communications
Computers and Peripherals	www.ti.com/computers
Consumer Electronics	www.ti.com/consumer-apps
Energy and Lighting	www.ti.com/energy
Industrial	www.ti.com/industrial
Medical	www.ti.com/medical
Security	www.ti.com/security
Space, Avionics and Defense	www.ti.com/space-avionics-defense
Video and Imaging	www.ti.com/video

TI E2E Community

e2e.ti.com

Looking for pricing, stock, or lifecycle information?

Click below to explore more details on WIN SOURCE:

 [View SN65LVP20DRFT on WIN SOURCE](#)

 [Texas Instruments](#) Information

Optimize Your Supply Chain with WIN SOURCE Solutions

-  Global Sourcing Solution
-  Obsolete Management
-  Cost Control Management
-  Shortage Management
-  Alternative Solution
-  Excess Inventory Management