



**THE DATASHEET OF  
DS64BR111SQE/NOPB**



# DS64BR111 Ultra Low Power 6.4 Gbps 2-Channel Repeaters with Input Equalization and Output De-Emphasis

Check for Samples: [DS64BR111](#)

## FEATURES

- **Two Channel Repeater for up to 6.4 Gbps**
  - **DS64BR111 : 1x Bidirectional Lane**
- **Low 65mW/Channel (Typical) Power Consumption, with Option to Power Down Unused Channels**
- **Advanced Signal Conditioning Features**
  - **Receive Equalization up to +25 dB**
  - **Transmit De-Emphasis up to -12 dB**
  - **Transmit VOD Control: 700 to 1200 mVp-p**
  - **< 0.2 UI of Residual DJ at 6.4 Gbps**
- **Programmable via Pin Selection, EEPROM or SMBus Interface**
- **Single Supply Operation Selectable: 2.5V or 3.3v**
- **Flow-Thru Pinout in 4mmx4mm 24-Pin Leadless WQFN Package**
- **>5kV HBM ESD Rating**
- **Industrial -40 to 85°C Operating Temperature Range**

## APPLICATIONS

- **High-Speed Active Copper Cable Modules and FR-4 Backplane in Communication Systems**
- **FC, SAS, SATA 3/6 Gbps (with OOB Detection), InfiniBand, CPRI, OBSAI, RXAUI and Many Others**

## DESCRIPTION

The DS64BR111 is an extremely low power, high performance dual-channel repeater for serial links with data rates up to 6.4 Gbps. The DS64BR111 pinout is configured as one bidirectional lane (one transmit, one receive channel).

The DS64BR111 features a powerful 4-stage continuous time linear equalizer (CTLE) to provide a boost of up to +25 dB at 3.2 GHz and open an input eye that is completely closed due to inter-symbol interference (ISI) induced by the interconnect mediums such as an FR-4 backplane or AWG-30 cables. The transmitter features a programmable output de-emphasis driver with up to -12 dB and allows amplitude voltage levels to be selected from 700 mVp-p to 1200 mVp-p to suit multiple application scenarios.

The programmable settings can be applied via pin settings, SMBus (I2C) protocol or an external EEPROM. When operating in the EEPROM mode, the configuration information is automatically loaded on power up – This eliminates the need for an external microprocessor or software driver.

Part of TI's PowerWise family of energy efficient devices, the DS64BR111 consumes just 65 mW/channel (typical), and allow the option to turn-off unused channels. This ultra low power consumption eliminates the need for external heat sinks and simplifies thermal management in active cable applications.



Please be aware that an important notice concerning availability, standard warranty, and use in critical applications of Texas Instruments semiconductor products and disclaimers thereto appears at the end of this data sheet.

All trademarks are the property of their respective owners.

PRODUCTION DATA information is current as of publication date. Products conform to specifications per the terms of the Texas Instruments standard warranty. Production processing does not necessarily include testing of all parameters.

Copyright © 2011–2013, Texas Instruments Incorporated

Typical Application

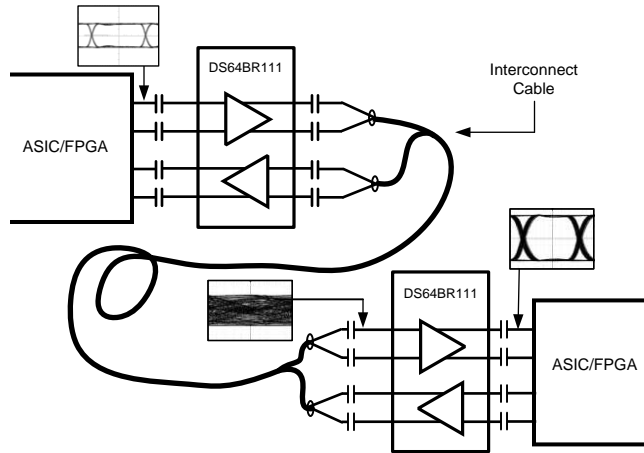

Block Diagram - Detail View Of Channel (1 Of 2)

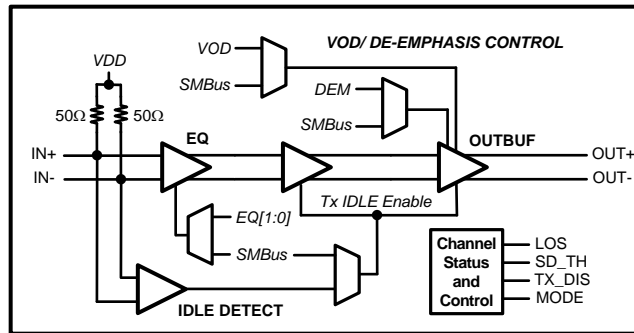

Pin Diagram

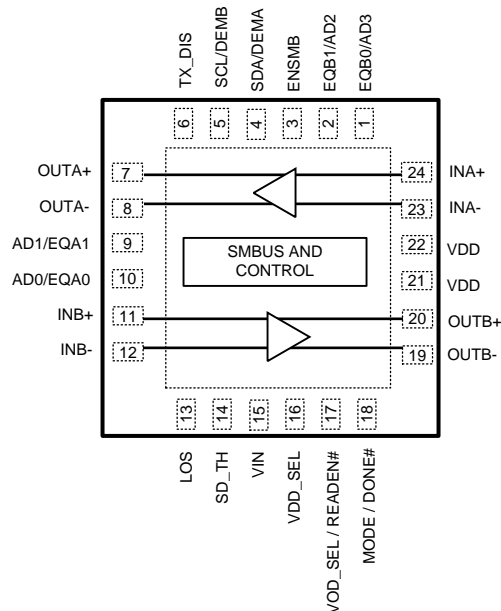

(1) The center DAP on the package bottom is the device GND connection. This pad must be connected to GND through multiple (minimum of 4) vias to ensure optimal electrical and thermal performance.

DS64BR111 Pin Diagram 24 lead

PIN DESCRIPTIONS

Pin Name	Pin Number	I/O, Type <sup>(1)</sup>	Pin Description
<b>Differential High Speed I/O's</b>			
INA+, INA-, INB+, INB-	24, 23 11, 12	I, CML	Inverting and non-inverting CML differential inputs to the equalizer. An on-chip 50Ω termination resistor connects INx+ to VDD and INx- to VDD when enabled.
OUTA+, OUTA-, OUTB+, OUTB-	7, 8 20, 19	O,CML	Inverting and non-inverting 50Ω driver outputs with de-emphasis. Compatible with AC coupled CML inputs.
<b>Control Pins</b>			
ENSMB	3	I, LVCMOS Float	System Management Bus (SMBus) enable pin Tie HIGH = Register Access, SMBus Slave mode FLOAT = SMBus Master read from External EEPROM Tie LOW = External Pin Control Mode
ENSMB = 1 (SMBUS MODE)			
SCL	5	I, LVCMOS O, Open Drain	ENSMB Master or Slave mode SMBUS clock input pin is enabled. A clock input in Slave mode. Can also be a clock output in Master mode.
SDA	4	I, LVCMOS, O, OPEN Drain	ENSMB Master or Slave mode The SMBus bidirectional SDA pin is enabled. Data input or open drain (pull-down only) output.

(1) LVCMOS inputs without the "Float" conditions must be driven to a logic low or high at all times or operation is not specified. Unless the "Float" level is desired; 4-Level input pins require a minimum 1K resistor to GND, VDD (in 2.5V mode), or VIN (in 3.3V mode). For additional information, [Table 1 Table 5](#)  
Input edge rate for LVCMOS/FLOAT inputs must be faster than 50 ns from 10–90%

**PIN DESCRIPTIONS (continued)**

Pin Name	Pin Number	I/O, Type <sup>(1)</sup>	Pin Description
AD0-AD3	10, 9, 2, 1	I, LVCMOS Float (4-Levels)	ENSMB Master or Slave mode SMBus Slave Address Inputs. In SMBus mode, these pins are the user set SMBus slave address inputs. There are 16 addresses supported by these pins. Pins must be tied LOW or HIGH when used to define the device SMBus address. <b>Note: Setting VOD_SEL = High in SMBus Mode will force the Address = B0'h</b>
READEN#	17	I, LVCMOS	When using an External EEPROM, a transition from high to low starts the load from the external EEPROM
DONE#	18	IO, LVCMOS, Float (4-Levels)	EEPROM Download Status HIGH indicates Error / Still Loading LOW indicates download complete. No Error.
<b>ENSMB = 0 (PIN MODE)</b>			
EQA0, EQA1 EQB0, EQB1	10, 9 1, 2	I, LVCMOS, Float (4-Levels)	EQA/B ,0/1 control the level of equalization of each channel. The EQA/B pins are active only when ENSMB is de-asserted (LOW). When ENSMB goes high the SMBus registers provide independent control of each lane, and the EQB0/B1 pins are converted to SMBUS AD2/AD3 inputs.
DEMA, DEMB	4, 5	IO, LVCMOS, Float (4-Levels)	DEMA/B controls the level of de-emphasis. The DEM A/B pins are only active when ENSMB is de-asserted (LOW). Each of the 4 A/B channels have the same level unless controlled by the SMBus control registers. When ENSMB goes high the SMBus registers provide independent control of each lane and the DEM pins are converted to SMBUS SCL and SDA pins.
TX_DIS	6	I, LVCMOS	DS64BR111 High = OUTA Enabled / OUTB Disabled Low = OUTA/B Enabled
VOD_SEL	17	I, LVCMOS, Float (4-Levels)	EQ Mode and VOD select. High = (VOD = 1.1V/1.3V) Float = (VOD = 1.0 V) 20K = (VOD = 1.2 V) Low = (VOD = 700m V) <b>Note: DS64BR111 OUTA is limited to 700mV in pin mode, see Table 4 for additional information.</b> <b>Note: Setting VOD_SEL = High in SMBus Mode will force the SMBus Address = B0'h</b>
VDD_SEL	16	I, Internal Pull-up	Enables the 3.3V to 2.5V internal regulator Low = 3.3 V Operation Float = 2.5 V Operation
MODE	18	I, LVCMOS	Controls Device Mode of Operation High = Continuous Talk Float = Slow OOB 20KΩ = eSATA Mode, Fast OOB, Auto Low Power on 100 uS of inactivity. SD stays active. Low = SAS Mode, Fast OOB
<b>Status Output</b>			
LOS	13	O, Open Drain	Indicates Loss of Signal (Default is LOS on INA). Can be modified via SMBus registers.
<b>LOS Threshold Input</b>			
SD_TH	14	I, LVCMOS, Float (4-Levels)	The SD_TH pin controls LOS threshold setting; Assert (mV), Deassert (mV) 20K = 160 mV, 100 mV Float = 180 mV, 110 mV (Default) High = 190 mV, 130 mV Low = 210 mV, 150 mV <b>Note: Using values less than the default level can extend the time required to detect LOS and are not recommended.</b>
<b>Power</b>			

**PIN DESCRIPTIONS (continued)**

Pin Name	Pin Number	I/O, Type <sup>(1)</sup>	Pin Description
VDD	21, 22	Power	Power supply pins 2.5V mode connect to 2.5V 3.3V mode do not connect to any supply voltage. Should be used to attach external decoupling to device. 100 - 200 nF recommended. <b>Note: See APPLICATION INFORMATION for additional information.</b>
VIN	15	Power	VIN = 3.3V +/-10% (input to internal LDO regulator) <b>Note: Must FLOAT for 2.5V operation. See APPLICATION INFORMATION for additional information.</b>
GND	DAP	Power	Ground pad (DAP - die attach pad).



These devices have limited built-in ESD protection. The leads should be shorted together or the device placed in conductive foam during storage or handling to prevent electrostatic damage to the MOS gates.

**ABSOLUTE MAXIMUM RATINGS<sup>(1)(2)</sup>**

Supply Voltage (VDD)	-0.5V to +2.75V
Supply Voltage (VIN)	-0.5V to +4.0V
LVC MOS Input/Output Voltage	-0.5V to +4.0V
CML Input Voltage	-0.5V to (VDD+0.5)
CML Input Current	-30 to +30 mA
Junction Temperature	125°C
Storage Temperature	-40°C to +125°C
ESD Rating	
HBM, STD - JESD22-A114F	> 5 kV
MM, STD - JESD22-A115-A	100 V
CDM, STD - JESD22-C101-D	1250 V
Package Thermal Resistance	
$\theta_{JC}$	3.2°C/W
$\theta_{JA}$ , No Airflow, 4 layer JEDEC	33.0°C/W
For soldering specifications: See product folder at <a href="http://www.ti.com">www.ti.com</a> <a href="http://www.ti.com/lit/SNOA549">http://www.ti.com/lit/SNOA549</a>	

- (1) "Absolute Maximum Ratings" indicate limits beyond which damage to the device may occur, including inoperability and degradation of device reliability and/or performance. Functional operation of the device and/or non-degradation at the Absolute Maximum Ratings or other conditions beyond those indicated in the Recommended Operating Conditions is not implied. The Recommended Operating Conditions indicate conditions at which the device is functional and the device should not be operated beyond such conditions. Absolute Maximum Numbers are specified for a junction temperature range of -40°C to +125°C. Models are validated to Maximum Operating Voltages only.
- (2) **If Military/Aerospace specified devices are required, please contact the Texas Instruments Sales Office / Distributors for availability and specifications.**

**RECOMMENDED OPERATING CONDITIONS**

	Min	Typ	Max	Units
Supply Voltage (2.5V Mode)	2.375	2.5	2.625	V
Supply Voltage (3.3V Mode)	3.0	3.3	3.6	V
Ambient Temperature	-40	25	+85	°C
SMBus (SDA, SCL)			3.6	V

**ELECTRICAL CHARACTERISTICS**

Symbol	Parameter	Conditions	Min	Typ	Max	Units
<b>Power Supply Current</b>						
IDD	Supply Current	TX_DIS = LOW, EQ = ON VOD_SEL = Float ( 1000 mV)		50	63	mA
		Auto Low Power Mode TX_DIS = LOW, MODE = 20K VID CHA and CHB = 0.0V VOD_SEL = Float (1000 mV)		12	15	
		TX_DIS = HIGH		25	35	
<b>LVCMOS DC Specifications</b>						
V <sub>IH</sub>	Voltage Input High		2.0		VDD	V
V <sub>IL</sub>	Voltage Input Low		GND		0.7	V
V <sub>OH</sub>	Voltage Output High	I <sub>OH</sub> = -4.0 mA <sup>(1)</sup>	2.0			V
V <sub>OL</sub>	Voltage Output Low	I <sub>OL</sub> = 4.0 mA			0.4	V
I <sub>IN</sub>	Input Leakage Current	V <sub>input</sub> = 0V or VDD VDD_SEL = Float	-15		+15	uA
		V <sub>input</sub> = 0V or VIN VDD_SEL = Low	-15		+15	
I <sub>IN-P</sub>	Input Leakage Current 4-Level Input	V <sub>input</sub> = 0V or VDD - 0.05 V VDD_SEL = Float V <sub>input</sub> = 0V or VIN - 0.05 V VDD_SEL = Low	-160		+80	uA
<b>LOS and ENABLE / DISABLE Timing</b>						
T <sub>LOS_OFF</sub>	Input IDLE to Active RX_LOS response time	See <sup>(2)</sup>		0.035		uS
T <sub>LOS_ON</sub>	Input Active to IDLE RX_LOS response time	See <sup>(2)</sup>		0.4		uS
T <sub>OFF</sub>	TX Disable assert Time TX_DIS = HIGH to Output OFF	See <sup>(2)</sup>		0.005		uS
T <sub>ON</sub>	TX Disable negateTime TX_DIS = LOW to Output ON	See <sup>(2)</sup>		0.150		uS
T <sub>LP_EXIT</sub>	Auto Low Power Exit ALP to Normal Operation	See <sup>(2)</sup>		150		nS
T <sub>LP_ENTER</sub>	Auto Low Power Enter Normal Operation to Auto Low Power	See <sup>(2)</sup>		100		uS
<b>CML RECEIVER INPUTS</b>						
V <sub>TX</sub>	Source Transmit Launch Signal Level	Default power-up conditions ENSMB = 0 or 1 VOD_SEL = Float	190	800	1600	mV
RL <sub>RX-IN</sub>	RX return loss	SDD11 @ 4.1 GHz		-12		dB
		SDD11 @ 11.1 GHz		-8		
		SCD11 @ 11.1 GHz		-10		
<b>HIGH SPEED TRANSMITTER OUTPUTS</b>						

(1) VOH only applies to the DONE# pin; LOS, SCL, and SDA are open-drain outputs that have no internal pull-up capability. DONE# is a full LVCMOS output with pull-up and pull-down capability

(2) Parameter not tested in production.

**ELECTRICAL CHARACTERISTICS (continued)**

Symbol	Parameter	Conditions	Min	Typ	Max	Units
V <sub>OD1</sub>	Output Voltage Differential Swing	OUT+ and OUT- AC coupled and terminated by 50Ω to GND VOD_SEL = LOW (700 mV setting) DE = LOW	500	650	800	mVp-p
V <sub>OD2</sub>	Output Voltage Differential Swing	OUT+ and OUT- AC coupled and terminated by 50Ω to GND VOD_SEL = FLOAT (1000 mV setting) DE = LOW	800	1000	1100	
V <sub>OD3</sub>	Output Voltage Differential Swing	OUT+ and OUT- AC coupled and terminated by 50Ω to GND VOD_SEL = 20K (1200 mV setting) DE = LOW	950	1150	1350	
V <sub>OD_DE1</sub>	De-Emphasis Levels	OUT+ and OUT- AC coupled and terminated by 50Ω to GND VOD_SEL = FLOAT (1000 mV setting) DE = FLOAT		-3		dB
V <sub>OD_DE2</sub>	De-Emphasis Levels	OUT+ and OUT- AC coupled and terminated by 50Ω to GND VOD_SEL = FLOAT (1000 mV setting) DE = 20K		-6		dB
V <sub>OD_DE3</sub>	De-Emphasis Levels	OUT+ and OUT- AC coupled and terminated by 50Ω to GND VOD_SEL = FLOAT (1000 mV setting) DE = HIGH		-9		dB
V <sub>CM-AC</sub>	Output Common-Mode Voltage	AC Common Mode Voltage DE = 0 dB, VOD ≤ 1000 mV		4.5		mV (RMS)
V <sub>CM-DC</sub>	Output DC Common-Mode Voltage	DC Common Mode Voltage	0	1.1	1.9	V
V <sub>IDLE</sub>	TX IDLE Output Voltage				30	mV
RL <sub>TX-DIFF</sub>	TX return loss	SDD22 @ 4.1 GHz		-13		dB
		SDD22 @ 11.1 GHz		-9		
		SCC22 @ 2.5 GHz		-22		
		SCC22 @ 11.1 GHz		-10		
delta Z <sub>M</sub>	Transmitter Termination Mismatch	DC, I <sub>FORCE</sub> = +/- 100 uA <sup>(3)</sup>		2.5		%
T <sub>R/F</sub>	Transmitter Rise and Fall Time	20% - 80% <sup>(4)</sup>		38		Ω
T <sub>PD</sub>	Propagation Delay	Measured at 50% crossing		230		ps
T <sub>CCSK</sub>	Channel to Channel Skew	T = 25°C, VDD = 2.5V		7		ps
T <sub>PPSK</sub>	Part to Part Channel Skew	T = 25°C, VDD = 2.5V		20		ps
T <sub>DI</sub>	Time to transition to valid electrical IDLE after an active burst in OOB signaling			6.5		ns
T <sub>ID</sub>	Time to transition to valid active burst after leaving electrical IDLE in OOB signaling			3.2		ns

(3) Force +/- 100 uA on output, measure delta V on the Output and calculate impedance. Mismatch is the percentage difference of OUTn+ and OUTn- impedance driving the same logic state.

(4) Default VOD used for testing. DE = -1.5 dB level used to compensate for fixture attenuation.

**ELECTRICAL CHARACTERISTICS (continued)**

Symbol	Parameter	Conditions	Min	Typ	Max	Units
T <sub>ENVELOPE_DISTORT</sub>	Active OOB timing distortion, input active time vs. output active time			3.3		ns
<b>OUTPUT JITTER SPECIFICATIONS<sup>(5)</sup></b>						
R <sub>J</sub>	Random Jitter	No Media Source Amplitude = 700 mV, PRBS15 pattern, 6.4 Gbps VOD = Default, EQ = minimum, DE = 0 dB		0.35		ps (RMS)
D <sub>J1</sub>	Deterministic Jitter			0.065		UI
<b>Equalization</b>						
D <sub>JE1</sub>	Residual Deterministic Jitter 10.3125 Gbps	8 meter 30AWG Cable on Input Source = 700 mV, PRBS15 pattern EQ = 0F'h; See <a href="#">Figure 15</a>		0.15		UI
D <sub>JE2</sub>	Residual Deterministic Jitter 6.4 Gbps	30" FR4 on Inputs Source = 800 mV, PRBS15 pattern EQ = 16'h; See <a href="#">Figure 13</a>		0.10		UI
<b>De-emphasis</b>						
D <sub>JD1</sub>	Residual Deterministic Jitter 6.4 Gbps	10" 4 mil stripline FR4 on Outputs Source = 700 mV, PRBS15 pattern EQ = 00 (Min), DE = 010'b See <a href="#">Figure 17</a>		0.085		UI

(5) Typical jitter reported is determined by jitter decomposition software on a DSA8200 Oscilloscope.

**ELECTRICAL CHARACTERISTICS — SERIAL MANAGEMENT BUS INTERFACE**

Over recommended operating supply and temperature ranges unless other specified.

Symbol	Parameter	Conditions	Min	Typ	Max	Units
<b>SERIAL BUS INTERFACE DC SPECIFICATIONS:<sup>(1)</sup></b>						
V <sub>IL</sub>	Data, Clock Input Low Voltage				0.8	V
V <sub>IH</sub>	Data, Clock Input High Voltage		2.1		3.6	V
I <sub>PULLUP</sub>	Current Through Pull-Up Resistor or Current Source	High Power Specification		4		mA
V <sub>DD</sub>	Nominal Bus Voltage		2.375		3.6	V
I <sub>LEAK-BUS</sub>	Input Leakage Per Bus Segment	See <sup>(2)</sup>	-200		+200	μA
C <sub>I</sub>	Capacitance for SDA and SCL	See <sup>(2)</sup> and <sup>(3)(4)</sup>			10	pF
R <sub>TERM</sub>	External Termination Resistance pull to V <sub>DD</sub> = 2.5V ± 5% OR 3.3V ± 10%	Pullup V <sub>DD</sub> = 3.3V <sup>(2) (3)(5)</sup>		2000		Ω
		Pullup V <sub>DD</sub> = 2.5V <sup>(2) (3)(5)</sup>		1000		Ω
<b>SERIAL BUS INTERFACE TIMING SPECIFICATIONS</b>						
FSMB	Bus Operating Frequency	ENSMB = VDD (Slave Mode)			400	kHz
		ENSMB = FLOAT (Master Mode) <sup>(2)</sup>	280	400	520	kHz
TBUF	Bus Free Time Between Stop and Start Condition		1.3			μs

(1) EEPROM interface requires 400 KHz capable EEPROM device.

(2) Recommended value.

(3) Recommended maximum capacitance load per bus segment is 400pF.

(4) Specified by Design and/or characterization. Parameter not tested in production.

(5) Maximum termination voltage should be identical to the device supply voltage.

**ELECTRICAL CHARACTERISTICS — SERIAL MANAGEMENT BUS INTERFACE (continued)**

Over recommended operating supply and temperature ranges unless other specified.

Symbol	Parameter	Conditions	Min	Typ	Max	Units
THD:STA	Hold time after (Repeated) Start Condition. After this period, the first clock is generated.	At I <sub>PULLUP</sub> , Max	0.6			μs
TSU:STA	Repeated Start Condition Setup Time		0.6			μs
TSU:STO	Stop Condition Setup Time		0.6			μs
THD:DAT	Data Hold Time		0			ns
TSU:DAT	Data Setup Time		100			ns
T <sub>LOW</sub>	Clock Low Period		1.3			μs
T <sub>HIGH</sub>	Clock High Period	See <sup>(6)</sup>	0.6		50	μs
t <sub>F</sub>	Clock/Data Fall Time	See <sup>(6)</sup>			300	ns
t <sub>R</sub>	Clock/Data Rise Time	See <sup>(6)</sup>			300	ns
t <sub>POR</sub>	Time in which a device must be operational after power-on reset	See <sup>(6)</sup> and <sup>(4)</sup>			500	ms

(6) Compliant to SMBus 2.0 physical layer specification. See System Management Bus (SMBus) Specification Version 2.0, section 3.1.1 SMBus common AC specifications for details.

**TIMING DIAGRAMS**

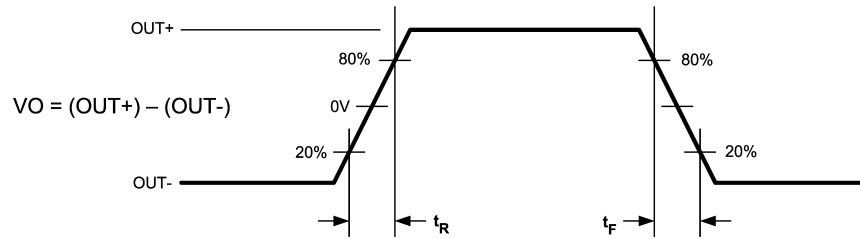

**Figure 1. CML Output Transition Times**

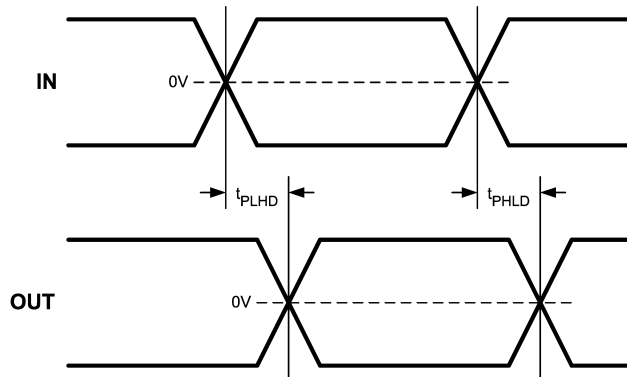

**Figure 2. Propagation Delay Timing Diagram**

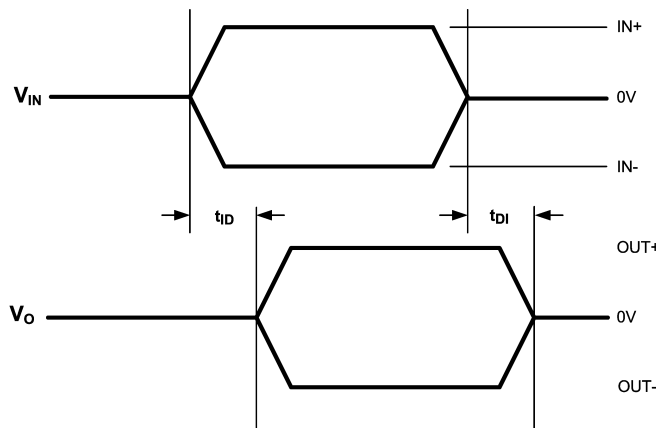

**Figure 3. Idle Timing Diagram**

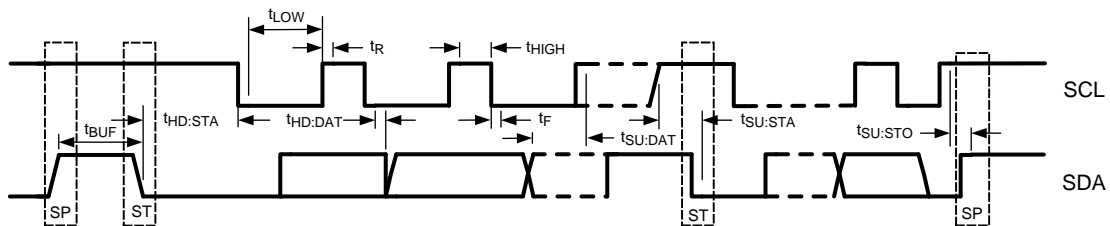

**Figure 4. SMBus Timing Parameters**

## FUNCTIONAL DESCRIPTION

The DS64BR111 is a high performance circuit capable of delivering excellent performance. Careful attention must be paid to the details associated with high-speed design as well as providing a clean power supply. Refer to the information below and Revision 4 of the LVDS Owner's Manual for more detailed information on high speed design tips to address signal integrity design issues.

The control pins have been enhanced to have 4 different levels and provide a wider range of control settings. Refer to [Table 1](#)

**Table 1. 4-Level Control Pin Settings**

Pin Setting	Description
0	Tie pin to GND through a 1 KΩ resistor
R	Tie pin to ground through 20 KΩ resistor
Float	Float the pin (no connection)
1	Tie pin to VDD through a 1 KΩ resistor

Note: 4-Level IO pins require a 1K resistance to GND or VDD/VIN. It is possible to tie multiple 4-level IO pins together with a single resistor to GND or VDD/VIN. When multiple IOs are connected in parallel, the resistance to GND or VDD/VIN should be adjusted to compensate. For 2 pins the optimal resistance is 500 Ohms, 3 pins = 330 Ohms, and 4 pins = 250 Ohms.

Note: For 2.5V mode the control pin logic 1 level is VDD (pins 21 and 22), in 3.3V mode the control pin logic 1 level is defined by VIN (pin 15).

**Table 2. Equalizer Settings**

Level	EQA1/EQB1	EQA0/EQB0	EQ — 8 bits [7:0]	dB Boost at 3.2 Ghz	Suggested Media
1	0	0	0000 0000 = 0x00	3.7	FR4 < 5 inch trace
2	0	R	0000 0001 = 0x01	6.0	FR4 5 inch trace
3	0	Float	0000 0010 = 0x02	7.5	FR4 10 inch trace
4	0	1	0000 0011 = 0x03	8.5	FR4 15 inch trace
5	R	0	0000 0111 = 0x07	11	FR4 20 inch trace
6	R	R	0001 0101 = 0x15	12	FR4 25 inch trace
7	R	Float	0000 1011 = 0x0B	14	FR4 25 inch trace
8	R	1	0000 1111 = 0x0F	15	7m 30AWG Cable
9	Float	0	0101 0101 = 0x55	15	FR4 30 inch trace
10	Float	R	0001 1111 = 0x1F	18	8m 30 AWG Cable FR4 35 inch trace
11	Float	Float	0010 1111 = 0x2F	20	10m 30 AWG Cable
12	Float	1	0011 1111 = 0x3F	22	10m - 12m, Cable
13	1	0	1010 1010 = 0xAA	23	
14	1	R	0111 1111 = 0x7F	25	
15	1	Float	1011 1111 = 0xBF	27	
16	1	1	1111 1111 = 0xFF	28	

Note: Settings are approximate and will change based on PCB material, trace dimensions, and driver waveform characteristics.

**Table 3. De-emphasis and Output Voltage Settings**

Level	VOD_SEL	DEMA/B	SMBus Register DEM Level	SMBus Register VOD Level	VOD (mV)	DEM (dB)
1	0	0	000	000	700	0
2	0	Float	010	000	700	- 3.5
3	0	R	011	000	700	- 6
4	0	1	101	000	700	- 9
5	Float	0	000	011	1000	0

**Table 3. De-emphasis and Output Voltage Settings (continued)**

6	Float	Float	010	011	1000	- 3.5
7	Float	R	011	011	1000	- 6
8	Float	1	101	011	1000	- 9
9	R	0	000	101	1200	- 0
10	R	Float	010	101	1200	- 3.5
11	R	R	011	101	1200	- 6
12	R	1	101	101	1200	- 9
13	1	0	000	100	1100	0
14	1	Float	001	100	1100	- 1.5
15	1	R	001	110	1300	- 1.5
16	1	1	010	110	1300	- 3.5

Note: The DS64BR111 VOD for OUTPUT A is limited to 700 mV in pin mode (ENSMB=0). With ENSMB = 1 or FLOAT, the VOD for OUTPUT A can be adjusted with SMBus register 0x23 [4:2] as shown in the SMBus Register Table.

Note: In SMBus Mode if VOD\_SEL is in the Logic 1 state (1K resistor to VIN/VDD) the DS64BR111 AD0-AD3 pins are internally forced to 0'h

**Table 4. Signal Detect Threshold Level**

SD_TH	SMBus REG bit [3:2] and [1:0]	Assert Level (Typical)	De-assert Level (Typical)
0	10	210 mV	150 mV
20K to GND	01	160 mV	100 mV
Float (Default)	00	180 mV	110 mV
1	11	190 mV	130 mV

Note: VDD = 2.5V, 25°C, and 010101 pattern at 6.4 Gbps

## APPLICATION INFORMATION

### 4-Level Input Configuration Guidelines

The 4-level input pins utilize a resistor divider to help set the 4 valid levels. There is an internal 30K pull-up and a 60K pull-down connected to the package pin. These resistors, together with the external resistor connection combine to achieve the desired voltage level. Using the 1K pull-up, 1K pull-down, no connect, and 20K pull-down provide the optimal voltage levels for each of the four input states.

**Table 5. 4-Level Input Voltage**

Level	Setting	3.3V Mode	2.5V Mode
0	01K to GND	0.1 V	0.08 V
R	20K to GND	$0.33 * V_{IN}$	$0.33 * V_{DD}$
F	FLOAT	$0.67 * V_{IN}$	$0.67 * V_{DD}$
1	1K to $V_{DD}/V_{IN}$	$V_{IN} - 0.05V$	$V_{IN} - 0.04V$

- Typical 4-Level Input Thresholds
  - Level 1 - 2 =  $0.2 V_{IN}$  or  $V_{DD}$
  - Level 2 - 3 =  $0.5 V_{IN}$  or  $V_{DD}$
  - Level 3 - 4 =  $0.8 V_{IN}$  or  $V_{DD}$

In order to minimize the startup current associated with the integrated 2.5V regulator the 1K pull-up / pull-down resistors are recommended. If several 4 level inputs require the same setting, it is possible to combine two or more 1K resistors into a single lower value resistor. As an example; combining two inputs with a single 500Ω resistor is a good way to save board space.

### PCB Layout Guidelines

The CML inputs and outputs have been optimized to work with interconnects using a controlled differential impedance of 85 - 100Ω. It is preferable to route differential lines exclusively on one layer of the board, particularly for the input traces. The use of vias should be avoided if possible. If vias must be used, they should be used sparingly and must be placed symmetrically for each side of a given differential pair. Whenever differential vias are used the layout must also provide for a low inductance path for the return currents as well. Route the differential signals away from other signals and noise sources on the printed circuit board. See AN-1187 ([SNOA401](#)) for additional information on WQFN packages.

Different transmission line topologies can be used in various combinations to achieve the optimal system performance. Impedance discontinuities at vias can be minimized or eliminated by increasing the swell around each hole and providing for a low inductance return current path. When the via structure is associated with thick backplane PCB, further optimization such as back drilling is often used to reduce the detrimental high frequency effects of stubs on the signal path.

### Power Supply Configuration Guidelines

The DS64BR111 can be configured for 2.5V operation or 3.3V operation. The lists below outline required connections for each supply selection.

#### 3.3V Mode of Operation

1. Tie VDD\_SEL = 0 with 1K resistor to GND.
2. Feed 3.3V supply into VIN pin. Local 1.0 uF decoupling at VIN is recommended.
3. See information on VDD bypass below.
4. SDA and SCL pins should connect pull-up resistor to VIN
5. Any 4-Level input which requires a connection to "Logic 1" should use a 1K resistor to VIN

#### 2.5V Mode of Operation

6. VDD\_SEL = Float
7. VIN = Float
8. Feed 2.5V supply into VDD pins.
9. See information on VDD bypass below.

10. SDA and SCL pins connect pull-up resistor to VDD for 2.5V uC SMBus IO
11. SDA and SCL pins connect pull-up resistor to VIN for 3.3V uC SMBus IO
12. Any 4-Level input which requires a connection to "Logic 1" should use a 1K resistor to VIN

Note: The DAP (bottom solder pad) is the GND connection.

## Power Supply Bypass

Two approaches are recommended to ensure that the DS64BR111 is provided with an adequate power supply. First, the supply (VDD) and ground (GND) pins should be connected to power planes routed on adjacent layers of the printed circuit board. The layer thickness of the dielectric should be minimized so that the V<sub>DD</sub> and GND planes create a low inductance supply with distributed capacitance. Second, careful attention to supply bypassing through the proper use of bypass capacitors is required. A 0.1 μF bypass capacitor should be connected to each V<sub>DD</sub> pin such that the capacitor is placed as close as possible to the device. Smaller body size capacitors can help facilitate proper component placement.

## System Management Bus (SMBus) and Configuration Registers

The System Management Bus interface is compatible to SMBus 2.0 physical layer specification. ENSMB must be pulled high to enable SMBus mode and allow access to the configuration registers.

The DS64BR111 has AD[3:0] inputs in SMBus mode. These pins are the user set SMBus slave address inputs. When pulled low the AD[3:0] = 0000'b, the device default address byte is B0'h. Based on the SMBus 2.0 specification, this configuration results in a 7-bit slave address of 1011000'b. The LSB is set to 0'b (for a WRITE), thus the 8-bit value is 1011 0000'b or B0'h. The device address byte can be set with the use of the AD[3:0] inputs.

Shown in the form of an expression:

Slave Address [7:4] = The DS64BR111 hardware address (1011'b) + Address pin AD[3]

Slave Address [3:1] = Address pins AD[2:0]

Slave Address [0] = 0'b for a WRITE or 1'b for a READ

Slave Address Examples:

- AD[3:0] = 0001'b, the device slave address byte is B2'h
  - Slave Address [7:4] = 1011'b + 0'b = 1011'b or B'h
  - Slave Address [3:1] = 001'b
  - Slave Address [0] = 0'b for a WRITE
- AD[3:0] = 0010'b, the device slave address byte is B4'h
  - Slave Address [7:4] = 1011'b + 0'b = 1011'b or B'h
  - Slave Address [3:1] = 010'b
  - Slave Address [0] = 0'b for a WRITE
- AD[3:0] = 0100'b, the device slave address byte is B8'h
  - Slave Address [7:4] = 1011'b + 0'b = 1011'b or B'h
  - Slave Address [3:1] = 100'b
  - Slave Address [0] = 0'b for a WRITE
- AD[3:0] = 1000'b, the device slave address byte is C0'h
  - Slave Address [7:4] = 1011'b + 1'b = 1100'b or C'h
  - Slave Address [3:1] = 000'b
  - Slave Address [0] = 0'b for a WRITE

## TRANSFER OF DATA VIA THE SMBus

During normal operation the data on SDA must be stable during the time when SCL is High.

There are three unique states for the SMBus:

**START:** A High-to-Low transition on SDA while SCL is High indicates a message START condition.

**STOP:** A Low-to-High transition on SDA while SCL is High indicates a message STOP condition.

**IDLE:** If SCL and SDA are both High for a time exceeding  $t_{BUF}$  from the last detected STOP condition or if they are High for a total exceeding the maximum specification for  $t_{HIGH}$  then the bus will transfer to the IDLE state.

**SMBus TRANSACTIONS**

The device supports WRITE and READ transactions. See Register Description table for register address, type (Read/Write, Read Only), default value and function information.

**WRITING A REGISTER**

To write a register, the following protocol is used (see SMBus 2.0 specification).

1. The Host drives a START condition, the 7-bit SMBus address, and a “0” indicating a WRITE.
2. The Device (Slave) drives the ACK bit (“0”).
3. The Host drives the 8-bit Register Address.
4. The Device drives an ACK bit (“0”).
5. The Host drive the 8-bit data byte.
6. The Device drives an ACK bit (“0”).
7. The Host drives a STOP condition.

The WRITE transaction is completed, the bus goes IDLE and communication with other SMBus devices may now occur.

**READING A REGISTER**

To read a register, the following protocol is used (see SMBus 2.0 specification).

1. The Host drives a START condition, the 7-bit SMBus address, and a “0” indicating a WRITE.
2. The Device (Slave) drives the ACK bit (“0”).
3. The Host drives the 8-bit Register Address.
4. The Device drives an ACK bit (“0”).
5. The Host drives a START condition.
6. The Host drives the 7-bit SMBus Address, and a “1” indicating a READ.
7. The Device drives an ACK bit “0”.
8. The Device drives the 8-bit data value (register contents).
9. The Host drives a NACK bit “1” indicating end of the READ transfer.
10. The Host drives a STOP condition.

The READ transaction is completed, the bus goes IDLE and communication with other SMBus devices may now occur.

Please see SMBus Register Map Table for more information for more information.

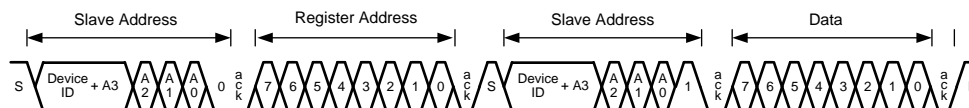

**Figure 5. Typical SMBus Write Operation**

**EEPROM Modes in DS64BR111 Device**

The DS64BR111 device supports reading directly from an external EEPROM device by implementing SMBus Master mode. When using the SMBus master mode, the DS64BR111 will read directly from specific location in the external EEPROM. When designing a system for using the external EEPROM, the user needs to follow these specific guidelines.

- Set the DS64BR111 into SMBus Master Mode
  - Float ENSMB (PIN 3)
- The external EEPROM device address byte must be 0xA0'h
- Set the AD[3:0] inputs for SMBus address byte. When the AD[3:0] = 0000'b, the device address byte is B0'h.

- Based on the SMBus 2.0 specification, a device can have a 7-bit slave address of 1011 000'b. The LSB is set to 0'b (for a WRITE). The bit mapping for SMBus is listed below:
  - [7:5] = Reserved Bits from the SMBus specification
  - [4:1] = Usable SMBus Address Bits
  - [0] = Write Bit
- The DS64BR111 devices have AD[3:0] inputs in SMBus mode (pins 1, 2, 9, 10). These pins set SMBus slave address. The AD[3:0] pins do not have any internal pull resistors. When the AD[3:0] = 0001'b, the device address byte is B2'h.
  - [7:5] = 4b'101
  - [4:1] = Address of 4'b0001
  - [0] = Write Bit, 1'b0
- The device address can be set with the use of the AD[3:0] input up to 16 different addresses. Use the example below to set each of the SMBus addresses.
  - AD[3:0] = 0001'b, the device address byte is B2'h
  - AD[3:0] = 0010'b, the device address byte is B4'h
  - AD[3:0] = 0011'b, the device address byte is B6'h
  - AD[3:0] = 0100'b, the device address byte is B8'h
- The master implementation in the DS64BR111, support multiple devices reading from 1 EEPROM. When tying multiple devices to the SDA and SCL pins, use these guidelines:
  - Use adjacent SMBus addresses for the 4 devices
  - Use a pull-up resistor on SDA; value = 4.7K $\Omega$
  - Use a pull-up resistor on SCL: value = 4.7K $\Omega$
  - Daisy-chain READEN# (pin 17) and DONE# (pin18) from one device to the next device in the sequence
    1. Tie READEN# of the 1st device in the chain (U1) to GND
    2. Tie DONE# of U1 to READEN# of U2
    3. Tie DONE# of U2 to READEN# of U3
    4. Tie DONE# of U3 to READEN# of U4
    5. Optional: Tie DONE# of U4 to a LED to show each of the devices have been loaded successfully

### ***Master EEPROM Mode in the DS100BR111***

Below is an example of a 2 kbits (256 x 8-bit) EEPROM in hex format for the DS100BR111 device. The first 3 bytes of the EEPROM always contain a header common and necessary to control initialization of all devices connected to the I2C bus. CRC enable flag to enable/disable CRC checking. There is a MAP bit to flag the presence of an address map that specifies the configuration data start in the EEPROM. If the MAP bit is not present the configuration data start address is derived from the DS100BR111 address and the configuration data size. A bit to indicate an EEPROM size > 256 bytes is necessary to properly address the EEPROM. There are 37 bytes of data size for each DS100BR111 device.

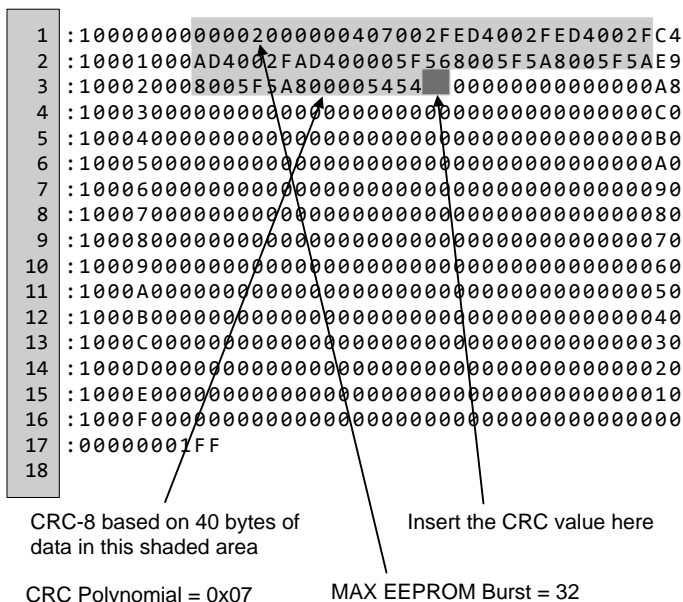

Figure 6. Typical EEPROM Data Set

The CRC-8 calculation is performed on the first 3 bytes of header information plus the 37 bytes of data for the DS64BR111 or 40 bytes in total. The result of this calculation is placed immediately after the DS64BR111 data in the EEPROM which ends with "5454". The CRC-8 in the DS64BR111 uses a polynomial =  $x^8 + x^2 + x + 1$

In SMBus master mode the DS64BR111 reads its initial configuration from an external EEPROM upon power-up. Some of the pins of the DS64BR111 perform the same functions in SMBus master and SMBus slave mode. Once the DS64BR111 has finished reading its initial configuration from the external EEPROM in SMBus master mode it reverts to SMBus slave mode and can be further configured by an external controller over the SMBus. The connection to an external SMBus master is optional and can be omitted for applications where additional security is desirable. There are two pins that provide unique functions in SMBus master mode.

- DONE#
- READEN#

When the DS64BR111 is powered up in SMBus master mode, it reads its configuration from the external EEPROM when the READEN# pin goes low. When the DS64BR111 is finished reading its configuration from the external EEPROM, it drives the DONE# pin low. In applications where there is more than one DS64BR111 on the same SMBus, bus contention can result if more than one DS64BR111 tries to take control of the SMBus at the same time. The READEN# and DONE# pins prevent this bus contention. The system should be designed so that the READEN# pin from one DS64BR111 in the system is driven low on power-up. This DS64BR111 will take command of the SMBus on power-up and will read its initial configuration from the external EEPROM. When it is finished reading its configuration, it will drive the DONE# pin low. This pin should be connected to the READEN# pin of another DS64BR111. When this DS64BR111 senses its READEN# pin driven low, it will take command of the SMBus and read its initial configuration from the external EEPROM, after which it will set its DONE# pin low. By connecting the DONE# pin of each DS64BR111 to the READEN# pin of the next DS64BR111, each DS64BR111 can read its initial configuration from the EEPROM without causing bus contention.

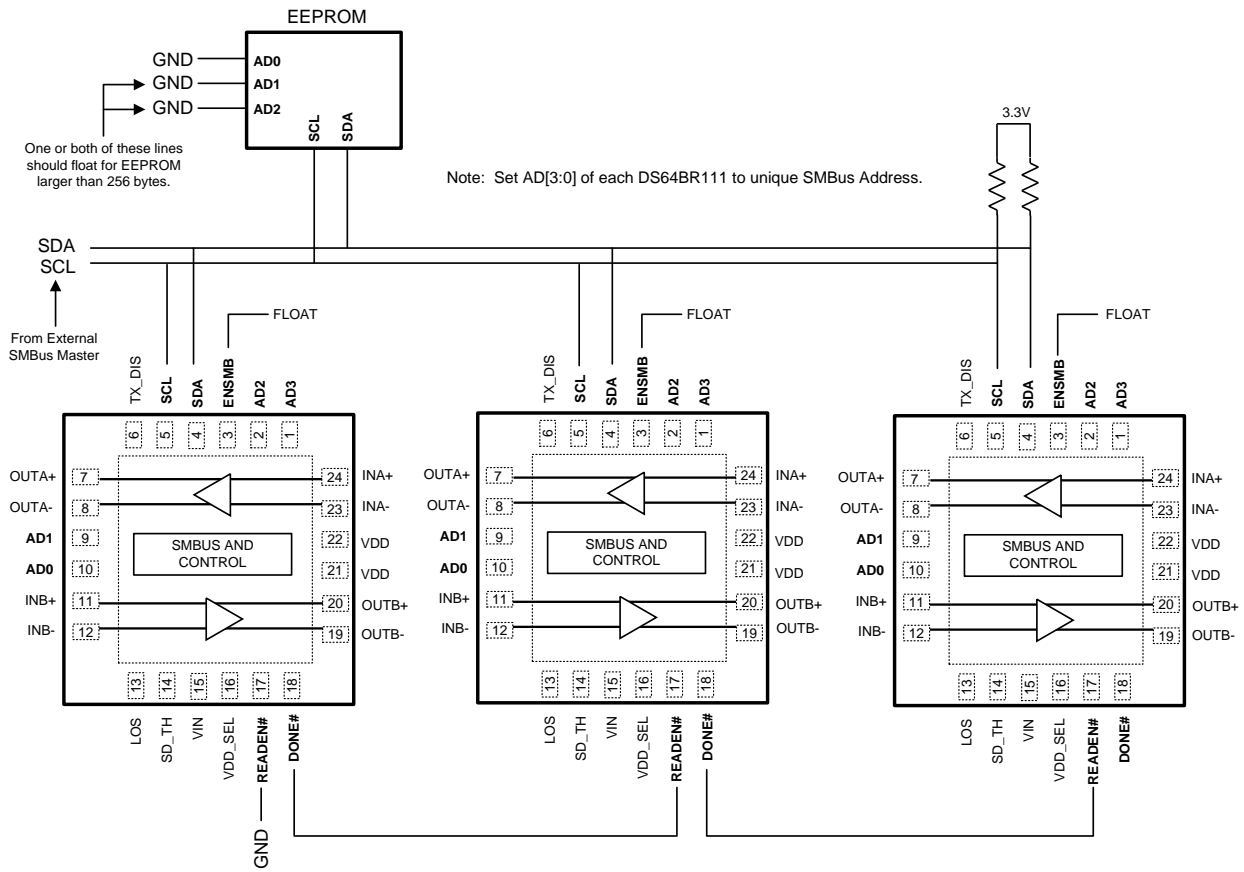

Figure 7. Typical multi-device EEPROM connection diagram

**Table 6. Multi-Device EEPROM Register Map Overview**

	Addr	Bit 7	Bit 6	Bit 5	Bit 4	Bit 3	Bit 2	Bit 1	Bit 0
Header	0	CRC EN	Address Map	EEPROM > 256 Bytes	Reserved	COUNT[3]	COUNT[2]	COUNT[1]	COUNT[0]
	1	Reserved	Reserved	Reserved	Reserved	Reserved	Reserved	Reserved	Reserved
	2	EE Burst[7]	EE Burst[6]	EE Burst[5]	EE Burst[4]	EE Burst[3]	EE Burst[2]	EE Burst[1]	EE Burst[0]
Device 0 Info	3	CRC[7]	CRC[6]	CRC[5]	CRC[4]	CRC[3]	CRC[2]	CRC[1]	CRC[0]
	4	EE AD0 [7]	EE AD0 [6]	EE AD0 [5]	EE AD0 [4]	EE AD0 [3]	EE AD0 [2]	EE AD0 [1]	EE AD0 [0]
Device 1 Info	5	CRC[7]	CRC[6]	CRC[5]	CRC[4]	CRC[3]	CRC[2]	CRC[1]	CRC[0]
	6	EE AD1 [7]	EE AD1 [6]	EE AD1 [5]	EE AD1 [4]	EE AD1 [3]	EE AD1 [2]	EE AD1 [1]	EE AD1 [0]
Device 2 Info	7	CRC[7]	CRC[6]	CRC[5]	CRC[4]	CRC[3]	CRC[2]	CRC[1]	CRC[0]
	8	EE AD2 [7]	EE AD2 [6]	EE AD2 [5]	EE AD2 [4]	EE AD2 [3]	EE AD2 [2]	EE AD2 [1]	EE AD2 [0]
Device 3 Info	9	CRC[7]	CRC[6]	CRC[5]	CRC[4]	CRC[3]	CRC[2]	CRC[1]	CRC[0]
	10	EE AD3 [7]	EE AD3 [6]	EE AD3 [5]	EE AD3 [4]	EE AD3 [3]	EE AD3 [2]	EE AD3 [1]	EE AD3 [0]
Device 0 Addr 3	11	RES	RES	RES	RES	RES	RES	RES	RES
Device 0 Addr 4	12	RES	RES	PDWN Inp	PDWN OSC	RES	eSATA CHA	eSATA CHB	Ovrd TX_DIS
Device 0 Addr 38	46	RES	RES	RES	RES	RES	RES	RES	RES
Device 0 Addr 39	47	RES	RES	RES	RES	RES	RES	RES	RES
Device 1 Addr 3	48	RES	RES	RES	RES	RES	RES	PWDN CH B	PWDN CH A
Device 1 Addr 4	49	RES	RES	PDWN Inp	PDWN OSC	RES	eSATA CHA	eSATA CHB	Ovrd TX_DIS
Device 1 Addr 38	83	RES	RES	RES	RES	RES	RES	RES	RES
Device 1 Addr 39	84	RES	RES	RES	RES	RES	RES	RES	RES
Device 2 Addr 3	85	RES	RES	RES	RES	RES	RES	PWDN CH B	PWDN CH A
Device 2 Addr 4	86	RES	RES	PDWN Inp	PDWN OSC	RES	eSATA CHA	eSATA CHB	Ovrd TX_DIS
Device 2 Addr 38	120	RES	RES	RES	RES	RES	RES	RES	RES
Device 2 Addr 39	121	RES	RES	RES	RES	RES	RES	RES	RES
Device 3 Addr 3	122	RES	RES	RES	RES	RES	RES	PWDN CH B	PWDN CH A
Device 3 Addr 4	123	RES	RES	PDWN Inp	PDWN OSC	RES	eSATA CHA	eSATA CHB	Ovrd TX_DIS
Device 3 Addr 38	157	RES	RES	RES	RES	RES	RES	RES	RES
Device 3 Addr 39	158	RES	RES	RES	RES	RES	RES	RES	RES

- CRC EN = 1; Address Map = 1
- EEPROM > 256 Bytes = 0
- COUNT[3:0] = 0011'b
- Note: Multiple DS64BR111 devices may point at the same address space if they have identical programming values.

**Table 7. Single EEPROM Header + Register Map with Default Value**

EEPROM Address Byte	Bit 7	Bit 6	Bit 5	Bit 4	Bit 3	Bit 2	Bit 1	Bit 0	
Description	0	CRC EN	Address Map Present	EEPROM > 256 Bytes	RES	COUNT[3]	COUNT[2]	COUNT[1]	COUNT[0]
Value		0	0	0	0	0	0	0	0
Description	1	RES	RES	RES	RES	RES	RES	RES	RES
Value		0	0	0	0	0	0	0	0
Description	2	Max EEPROM Burst size[7]	Max EEPROM Burst size[6]	Max EEPROM Burst size[5]	Max EEPROM Burst size[4]	Max EEPROM Burst size[3]	Max EEPROM Burst size[2]	Max EEPROM Burst size[1]	Max EEPROM Burst size[0]
Value		0	0	0	0	0	0	0	0
Description	3	Reserved	Reserved	Reserved	Reserved	Reserved	Reserved	Reserved	Reserved
Register		0x01[7]	0x01[6]	0x01[5]	0x01[4]	0x01[3]	0x01[2]	0x01 [1]	0x01 [0]
Value		0	0	0	0	0	0	0	0
Description	4	Ovrd_LOS	LOS_Value	PDWN Inp	PWDN Osc	Reserved	eSATA Enable A	eSATA Enable B	Ovrd TX_DIS
Register		0x02[5]	0x02[4]	0x02 [3]	0x02 [2]	0x02 [0]	0x04 [7]	0x04 [6]	0x04 [5]
Value		0	0	0	0	0	0	0	0
Description	5	TX_DIS CHA	TX_DIS CHB	Reserved	EQ Stage 4 CHB	EQ Stage 4 CHA	Reserved	Override IDLE_th	Reserved
Register		0x04 [4]	0x04 [3]	0x04 [2]	0x04 [1]	0x04 [0]	0x06[4]	0x08 [6]	0x08 [5]
Value		0	0	0	0	0	1	0	0
Description	6	Ovrd_IDLE	Reserved	Reserved	Reserved	Reserved	Reserved	Reserved	Reserved
Register		0x08 [4]	0x08[3]	0x08 [2]	0x08[1]	0x08[0]	0x0B[6]	0x0B[5]	0x0B[4]
Value		0	0	0	0	0	1	1	1
Description	7	Reserved	Reserved	Reserved	Reserved	Idle auto A	Idle sel A	Reserved	Reserved
Register		0x0B[3]	0x0B[2]	0x0B[1]	0x0B[0]	0x0E [5]	0x0E [4]	0x0E[3]	0x0E[2]
Value		0	0	0	0	0	0	0	0
Description	8	CHA EQ[7]	CHA EQ[6]	CHA EQ[5]	CHA EQ[4]	CHA EQ[3]	CHA EQ[2]	CHA EQ[1]	CHA EQ[0]
Register		0x0F [7]	0x0F [6]	0x0F [5]	0x0F [4]	0x0F [3]	0x0F [2]	0x0F [1]	0x0F [0]
Value		0	0	1	0	1	1	1	1
Description	9	A Sel scp	A Out Mode	Reserved	Reserved	Reserved	Reserved	Reserved	Reserved
Register		0x10 [7]	0x10 [6]	0x10 [5]	0x10 [4]	0x10 [3]	0x10[2]	0x10[1]	0x10[0]
Value		1	1	1	0	1	1	0	1
Description	10	DEMA[2]	DEMA[1]	DEMA[0]	CHA Slow	IDLE thA[1]	IDLE thA[0]	IDLE thD[1]	IDLE thD[0]
Register		0x11 [2]	0x11 [1]	0x11 [0]	0x12 [7]	0x12 [3]	0x12 [2]	0x12 [1]	0x12 [0]
Value		0	1	0	0	0	0	0	0
Description	11	Idle auto B	Idle sel B	Reserved	Reserved	CHB EQ[7]	CHB EQ[6]	CHB EQ[5]	CHB EQ[4]
Register		0x15 [5]	0x15 [4]	0x15[3]	0x15[2]	0x16 [7]	0x16 [6]	0x16 [5]	0x16 [4]
Value		0	0	0	0	0	0	1	0
Description	12	CHB EQ[3]	CHB EQ[2]	CHB EQ[1]	CHB EQ[0]	B Sel scp	B Out Mode	Reserved	Reserved
Register		0x16 [3]	0x16 [2]	0x16 [1]	0x16 [0]	0x17 [7]	0x17 [6]	0x17 [5]	0x17 [4]
Value		1	1	1	1	1	1	1	0
Description	13	Reserved	Reserved	Reserved	Reserved	CHB DEM[2]	CHB DEM[1]	CHB DEM[0]	CHB Slow
Register		0x17 [3]	0x17[2]	0x17[1]	0x17[0]	0x18 [2]	0x18 [1]	0x18 [0]	0x19 [7]
Value		1	1	0	1	0	1	0	0
Description	14	IDLE thA[1]	IDLE thA[0]	IDLE thD[1]	IDLE thD[0]	Reserved	Reserved	Reserved	Reserved
Register		0x19 [3]	0x19 [2]	0x19 [1]	0x19 [0]				
Value		0	0	0	0	0	0	0	0

**Table 7. Single EEPROM Header + Register Map with Default Value (continued)**

EEPROM Address Byte	Bit 7	Bit 6	Bit 5	Bit 4	Bit 3	Bit 2	Bit 1	Bit 0	
Description	15	Reserved	Reserved	Reserved	Reserved	Reserved	Reserved	Reserved	
Register									
Value		0	0	1	0	1	1	1	
Description	16	Reserved	Reserved	Reserved	Reserved	Reserved	Reserved	Reserved	
Register									
Value		1	0	1	0	1	1	0	
Description	17	Reserved	Reserved	Reserved	Reserved	Reserved	Reserved	Reserved	
Register									
Value		0	1	0	0	0	0	0	
Description	18	Reserved	A VOD[2]	A VOD[1]	A VOD[0]	Reserved	Reserved	Reserved	
Register			0x23 [4]	0x23 [3]	0x23 [2]				
Value		0	0	0	0	0	0	1	
Description	19	Reserved	Reserved	Reserved	Reserved	Reserved	Reserved	Reserved	
Register								0x25 [4]	
Value		1	1	1	1	1	0	1	
Description	20	Reserved	Reserved	Reserved	Reserved	Reserved	Reserved	Reserved	
Register		0x25 [3]	0x25 [2]						
Value		1	1	0	1	0	1	0	
Description	21	Reserved	Reserved	Reserved	Reserved	ovrd fst idle	en hi idle th A	en hi idle th B	en fst idle A
Register						0x28 [6]	0x28 [5]	0x28 [4]	0x28 [3]
Value		0	0	0	0	0	0	0	1
Description	22	en fst idle B	sd mgain A	sd mgain B	Reserved	Reserved	Reserved	Reserved	Reserved
Register		0x28 [2]	0x28 [1]	0x28 [0]					
Value		1	0	0	0	0	0	0	0
Description	23	Reserved	Reserved	Reserved	Reserved	Reserved	Reserved	Reserved	Reserved
Register									
Value		0	1	0	1	1	1	1	1
Description	24	Reserved	Reserved	Reserved	Reserved	B VOD[2]	B VOD[1]	B VOD[0]	Reserved
Register						0x2D [4]	0x2D [3]	0x2D [2]	
Value		0	1	0	1	1	0	1	0
Description	25	Reserved	Reserved	Reserved	Reserved	Reserved	Reserved	Reserved	Reserved
Register									
Value		1	0	0	0	0	0	0	0
Description	26	Reserved	Reserved	Reserved	Reserved	Reserved	Reserved	Reserved	Reserved
Register									
Value		0	0	0	0	0	1	0	1
Description	27	Reserved	Reserved	Reserved	Reserved	Reserved	Reserved	Reserved	Reserved
Register									
Value		1	1	1	1	0	1	0	1
Description	28	Reserved	Reserved	Reserved	Reserved	Reserved	Reserved	Reserved	Reserved
Register									
Value		1	0	1	0	1	0	0	0
Description	29	Reserved	Reserved	Reserved	Reserved	Reserved	Reserved	Reserved	Reserved
Register									
Value		0	0	0	0	0	0	0	0

**Table 7. Single EEPROM Header + Register Map with Default Value (continued)**

EEPROM Address Byte		Bit 7	Bit 6	Bit 5	Bit 4	Bit 3	Bit 2	Bit 1	Bit 0
Description	30	Reserved	Reserved	Reserved	Reserved	Reserved	Reserved	Reserved	Reserved
Register									
Value		0	1	0	1	1	1	1	1
Description	31	Reserved	Reserved	Reserved	Reserved	Reserved	Reserved	Reserved	Reserved
Register									
Value		0	1	0	1	1	0	1	0
Description	32	Reserved	Reserved	Reserved	Reserved	Reserved	Reserved	Reserved	Reserved
Register									
Value		1	0	0	0	0	0	0	0
Description	33	Reserved	Reserved	Reserved	Reserved	Reserved	Reserved	Reserved	Reserved
Register									
Value		0	0	0	0	0	1	0	1
Description	34	Reserved	Reserved	Reserved	Reserved	Reserved	Reserved	Reserved	Reserved
Register									
Value		1	1	1	1	0	1	0	1
Description	35	Reserved	Reserved	Reserved	Reserved	Reserved	Reserved	Reserved	Reserved
Register									
Value		1	0	1	0	1	0	0	0
Description	36	Reserved	Reserved	Reserved	Reserved	Reserved	Reserved	Reserved	Reserved
Register									
Value		0	0	0	0	0	0	0	0
Description	37	Reserved	Reserved	Reserved	Reserved	Reserved	Reserved	Reserved	Reserved
Register									
Value		0	0	0	0	0	0	0	0
Description	38	Reserved	Reserved	Reserved	Reserved	Reserved	Reserved	Reserved	Reserved
Register									
Value		0	1	0	1	0	1	0	0
Description	39	Reserved	Reserved	Reserved	Reserved	Reserved	Reserved	Reserved	Reserved
Register									
Value		0	1	0	1	0	1	0	0

Below is an example of a 2 kbits (256 x 8-bit) EEPROM Register Dump in hex format for a multi-device DS64BR111 application.

**Table 8. Multi DS100BR111 EEPROM Data**

EEPROM Address	Address (Hex)	EEPROM Data	Comments
0	00	0x43	CRC_EN = 0, Address Map = 1, Device Count = 3 (Devices 0, 1, 2, and 3)
1	01	0x00	
2	02	0x08	EEPROM Burst Size
3	03	0x00	CRC not used
4	04	0x0B	Device 0 Address Location
5	05	0x00	CRC not used
6	06	0x30	Device 1 Address Location
7	07	0x00	CRC not used
8	08	0x30	Device 2 Address Location
9	09	0x00	CRC not used

**Table 8. Multi DS100BR111 EEPROM Data (continued)**

EEPROM Address	Address (Hex)	EEPROM Data	Comments
10	0A	0x0B	Device 3 Address Location
11	0B	0x00	Begin Device 0 and Device 3 - Address Offset 3
12	0C	0x00	
13	0D	0x04	
14	0E	0x07	
15	0F	0x00	
16	10	0x2F	Default EQ CHA
17	11	0xED	
18	12	0x40	
19	13	0x02	Default EQ CHB
20	14	0xFE	Default EQ CHB
21	15	0xD4	
22	16	0x00	
23	17	0x2F	
24	18	0xAD	
25	19	0x40	
26	1A	0x02	BR111 CHA VOD = 700 mV
27	1B	0xFA	
28	1C	0xD4	
29	1D	0x01	
30	1E	0x80	
31	1F	0x5F	
32	20	0x56	BR111 CHB VOD = 1000 mV
33	21	0x80	
34	22	0x05	
35	23	0xF5	
36	24	0xA8	
37	25	0x00	
38	26	0x5F	
39	27	0x5A	
40	28	0x80	
41	29	0x05	
42	2A	0xF5	
43	2B	0xA8	
44	2C	0x00	
45	2D	0x00	
46	2E	0x54	
47	2F	0x54	End Device 0 and Device 3 - Address Offset 39
48	30	0x00	Begin Device 1 and Device 2 - Address Offset 3
49	31	0x00	
50	32	0x04	
51	33	0x07	
52	34	0x00	
53	35	0x2F	Default EQ CHA
54	36	0xED	
55	37	0x40	
56	38	0x02	Default EQ CHB

**Table 8. Multi DS100BR111 EEPROM Data (continued)**

EEPROM Address	Address (Hex)	EEPROM Data	Comments
57	39	0xFE	Default EQ CHB
58	3A	0xD4	
59	3B	0x00	
60	3C	0x2F	
61	3D	0xAD	
62	3E	0x40	
63	3F	0x02	BR111 CHA VOD = 700 mV
64	40	0xFA	
65	41	0xD4	
66	42	0x01	
67	43	0x80	
68	44	0x5F	
69	45	0x56	BR111 CHB VOD = 1000 mV
70	46	0x80	
71	47	0x05	
72	48	0xF5	
73	49	0xA8	
74	4A	0x00	
75	4B	0x5F	
76	4C	0x5A	
77	4D	0x80	
78	4E	0x05	
79	4F	0xF5	
80	50	0xA8	
81	51	0x00	
82	52	0x00	
83	53	0x54	
84	54	0x54	End Device 1 and Device 2 - Address Offset 39

**Table 9. SMBus Register Map**

Address	Register Name	Bits	Field	Type	Default	EEPROM Reg Bit	Description	
0x00	Device ID	7	Reserved	R/W	0x00		set bit to 0	
		6:3	I2C Address [3:0]	R			[6:3] SMBus strap observation	
		2	EEPROM reading done	R			1: EEPROM Loading 0: EEPROM Done Loading	
		1	Reserved	RWS C			set bit to 0	
		0	Reserved	RWS C			set bit to 0	
0x01	Control 1	7:6	Idle Control	R/W	0x00	Yes	Control [7]: Continuous talk ENABLE (Channel A) [6]: Continuous talk ENABLE (Channel B) [2]: LOS SEL Channel B	
		5:3	Reserved	R/W			Set bits to 0	
		2	LOS Select	R/W			LOS Monitor Selection 1: Use LOS from CH B 0: Use LOS from CH A	
		1:0	Reserved	R/W			Set bits to 00'b	
0x02	Control 2	7	Reserved	R/W	0x00		Set bit to 0	
		6	Reserved				Set bit to 0	
		5	LOS override				Yes	LOS pin override enable (1); Use Normal Signal Detection (0)
		4	LOS override value				Yes	1: Normal Operation 0: Output LOS
		3	PWDN Inputs				Yes	1: PWDN
		2	PWDN Oscillator				Yes	0: Normal Operation
		1	Reserved					
		0	Reserved				Yes	Set bit to 0
0x04	Control 3	7:6	eSATA Mode Enable	R/W	0x00	Yes	[7] Channel A (1) [6] Channel B (1)	
		5	TX_DIS Override Enable				1: Override Use Reg 0x04[4:3] 0: Normal Operation - uses pin	
		4	TX_DIS Value Channel A				1: TX Disabled 0: TX Enabled	
		3	TX_DIS Value Channel B					
		2	Reserved				Set bit to 0	
		1:0	EQ CONTROL					[1]: Channel B - EQ Stage 4 ON/OFF [0]: Channel A - EQ Stage 4 ON/OFF
0x05	CRC 1	7:0	CRC[7:0]	R/W	0x00		Slave Mode CRC Bits	
0x06	CRC 2	7	Disable EEPROM CFG	R/W	0x10		Disable Master Mode EEPROM Configuration	
		6:5	Reserved				Set bits to 0	
		4	Reserved				Yes	Set bit to 1
		3	CRC Slave Mode Disable					[1]: CRC Disable (No CRC Check) [0]: CRC Check ENABLE Note: With CRC check DISABLED register updates take immediate effect on high speed data path. With CRC check ENABLED register updates will NOT take effect until correct CRC value is loaded
		2:1	Reserved				Set bits to 0	
		0	CRC Enable					Slave CRC Trigger

**Table 9. SMBus Register Map (continued)**

Address	Register Name	Bits	Field	Type	Default	EEPROM Reg Bit	Description
0x07	Digital Reset and Control	7	Reserved	R/W	0x01		Set bit to 0
		6	Reset Regs				Self clearing reset for registers Writing a [1] will return register settings to default values.
		5	Reset SMBus Master				Self clearing reset for SMBus master state machine
		4:0	Reserved				Set bits to '0001b
0x08	Pin Override	7	Reserved	R/W	0x00		Set bit to 0
		6	Override Idle Threshold				Yes [1]: Override by Channel - see Reg 0x13 and 0x19 [0]: SD_TH pin control
		5	Reserved				Yes Set bit to 0
		4	Override IDLE				Yes [1]: Force IDLE by Channel - see Reg 0x0E and 0x15 [0]: Normal Operation
		3	Reserved				Yes Set bit to 0
		2	Override Out Mode				[1]: Enable Output Mode control for individual outputs. See register locations 0x10[6] and 0x17[6]. [0]: Disable - Outputs are kept in the normal mode of operation allowing VOD and DE adjustments.
		1	Override DEM				Yes
		0	Reserved				Yes Set bit to 0
0x0C	CH A Analog Override 1	7	Reserved	R/W	0x00		Set bit to 0
		6	Reserved				Set bit to 0
		5	Reserved				Set bit to 0
		4	Reserved				Set bit to 0
		3:0	Reserved				Set bits to 0000'b..
0x0D	CH A Reserved	7:0	Reserved	R/W	0x00		Set bits to 00'h.
0x0E	CH A Idle Control	7:6	Reserved	R/W	0x00		Set bits to 00'b.
		5	Idle Auto				Yes Auto IDLE value when override bit is set (reg 0x08 [4] = 1)
		4	Idle Select				Yes Force IDLE value when override bit is set (reg 0x08 [4] = 1)
		3	Reserved				Yes Set bit to 0.
		2:0	Reserved				Set bits to 0.
0x0F	CH A EQ Setting	7:0	BOOST [7:0]	R/W	0x2F	Yes	EQ Boost Default to 24 dB See EQ Table for Information
0x10	CH A Control 1	7	Sel_scp	R/W	0xED	Yes	1 = Short Circuit Protection ON 0 = Short Circuit Protection OFF
		6	Reserved			Yes Set bit to 1	
		5:3	Reserved			Yes Set bits to = 101'b	
		2:0	Reserved			Yes Set bits to = 101'b	

**Table 9. SMBus Register Map (continued)**

Address	Register Name	Bits	Field	Type	Default	EEPROM Reg Bit	Description	
0x11	CH A Control 2	7:5	Reserved	R	0x82		Set bits to = 100'b	
		4	Reserved	R/W			Set bit to 0	
		3	Reserved				Set bit to 0	
		2:0	DEM [2:0]				Yes	De-Emphasis (Default = -3.5 dB) 000'b = -0.0 dB 001'b = -1.5 dB 010'b = -3.5 dB 011'b = -6.0 dB 100'b = -8.0 dB 101'b = -9.0 dB 110'b = -10.5 dB 111'b = -12.0 dB
0x12	CH A Idle Threshold	7	Slow OOB	R/W	0x00	Yes	Slow OOB Enable (1); Disable (0)	
		6:4	Reserved			Set bits to 000'b.		
		3:2	idle_thA[1:0]			Yes	Assert Thresholds Use only if register 0x08 [6] = 1 00 = 180 mV (Default) 01 = 160 mV 10 = 210 mV 11 = 190 mV	
		1:0	idle_thD[1:0]			Yes	De-assert Thresholds Use only if register 0x08 [6] = 1 00 = 110 mV (Default) 01 = 100 mV 10 = 150 mV 11 = 130 mV	
0x13	CH B Analog Override 1	7	Reserved	R/W	0x00		Set bit to 0	
		6	Reserved				Set bit to 0	
		5	Reserved				Set bit to 0	
		4	Reserved				Set bit to 0	
		3:0	Reserved				Set bits to 0000'b.	
0x14	CH B Reserved	7:0	Reserved	R/W	0x00		Set bits to 00'h.	
0x15	CH B Idle Control	7:6	Reserved	R/W	0x00		Set bits to 00'b	
		5	Idle Auto				Yes	Auto IDLE value when override bit is set (reg 0x08 [4] = 1)
		4	Idle Select				Yes	Force IDLE value when override bit is set (reg 0x08 [4] = 1)
		3:2	Reserved				Yes	Set bits to 00'b.
		1:0	Reserved					Set bits to 00'b.
0x16	CH B EQ Setting	7:0	BOOST [7:0]	R/W	0x2F	Yes	EQ Boost Default to 24 dB See EQ Table for Information	

**Table 9. SMBus Register Map (continued)**

Address	Register Name	Bits	Field	Type	Default	EEPROM Reg Bit	Description
0x17	CH B Control 1	7	Sel_scp	R/W	0xED	Yes	1 = Short Circuit Protection ON 0 = Short Circuit Protection OFF
		6	Reserved			Yes	Set bit to 1
		5:3	Reserved			Yes	Set bits to = 101'b
		2:0	Reserved				Set bits to = 101'b
0x18	CH B Control 2	7:5	Reserved	R	0x82		Set bits to = 100'b
		4	Reserved	R/W			Set bit to 0
		3	Reserved				Set bit to 0
		2:0	DEM [2:0]			Yes	De-Emphasis (Default = -3.5 dB) 000'b = -0.0 dB 001'b = -1.5 dB 010'b = -3.5 dB 011'b = -6.0 dB 100'b = -8.0 dB 101'b = -9.0 dB 110'b = -10.5 dB 111'b = -12.0 dB
0x19	CH B Idle Threshold	7	Slow OOB	R/W	0x00	Yes	Slow OOB Enable (1); Disable (0)
		6:4	Reserved				Set bits to 000'b.
		3:2	idle_thA[1:0]			Yes	Assert Thresholds Use only if register 0x08 [6] = 1 00 = 180 mV (Default) 01 = 160 mV 10 = 210 mV 11 = 190 mV
		1:0	idle_thD[1:0]			Yes	De-assert Thresholds Use only if register 0x08 [6] = 1 00 = 110 mV (Default) 01 = 100 mV 10 = 150 mV 11 = 130 mV
0x23	BR111 CH A VOD	7:6	Reserved	R/W	0x00		Set bits to 00'b.
		4:2	VOD_CH0[2:0]			Yes	DS64BR111 VOD Controls for CH A (Default = 000'b) 000'b = 700 mV 001'b = 800 mV 010'b = 900 mV 011'b = 1000 mV 100'b = 1100 mV 101'b = 1200 mV 110'b = 1300 mV
		1:0	Reserved				Set bits to 00'b.
0x25	Reserved	7:5	Reserved	R/W	0xAD		Set bits to 101'b.
		4:2	Reserved			Yes	Set bits to 011'b.
		1:0	Reserved				Set bits to 01'b.
0x28	Idle Control	7	Reserved	R/W	0x00		
		6	Override Fast Idle			Yes	
		5:4	en_high_idle_th[1:0]			Yes	Enable high SD thresholds [5]: CH A [4]: CH B
		3:2	en_fast_idle[1:0]			Yes	Enable Fast IDLE [3]: CH A [2]: CH B
		1:0	Reserved			Yes	Set bits to 00'b.

**Table 9. SMBus Register Map (continued)**

Address	Register Name	Bits	Field	Type	Default	EEPROM Reg Bit	Description
0x2D	CH B VOD Control	7:5	Reserved	R/W	0xAD		Set bits to '101'b.
		4:2	VOD_CH0[2:0]			Yes	VOD Controls for CH B (Default = '011'b) 000'b = 700 mV 001'b = 800 mV 010'b = 900 mV 011'b = 1000 mV 100'b = 1100 mV 101'b = 1200 mV 110'b = 1300 mV
		1:0	Reserved				Set bits to '01'b
0x51	Device Information	7:5	Version[2:0]	R	0x47		Read bits = '010'b
		4:0	Device ID[4:0]				BR111 = '0 0111b

### TYPICAL DC PERFORMANCE CHARACTERISTICS

The following data was collected at 25°C

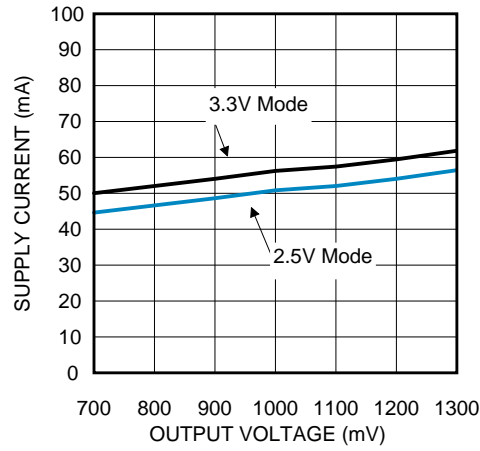

Figure 8. Supply Current vs. Output Voltage Setting

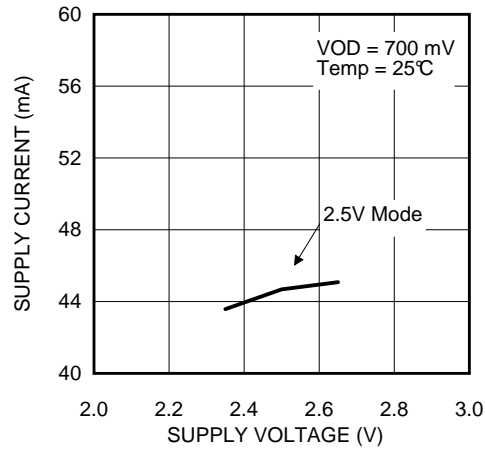

Figure 9. Supply Current vs. Supply Voltage

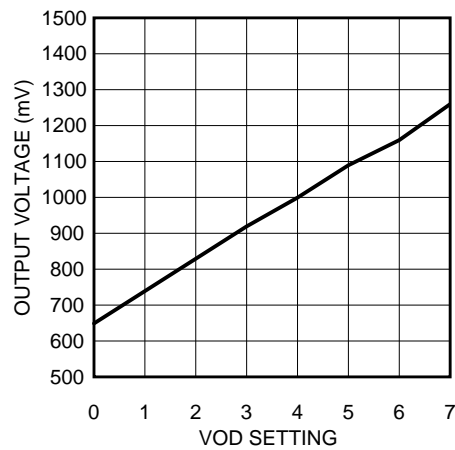

Figure 10. Output Voltage vs. Output Voltage Setting

TYPICAL AC PERFORMANCE CHARACTERISTICS

NO MEDIA:

Device	Random Jitter (Rj)	Deterministic Jitter (Dj)	Dj Component Breakdown	Total Jitter (Tj @ 1E-12)
DS100BR111 @ 10.3125 Gbps	340 fs	9.5 ps	DDJ = 7.4 ps	12.3 ps
			DCD = 1.0 ps	
			DDPWS = 6.3 ps	
			PJ = 0.81 ps	

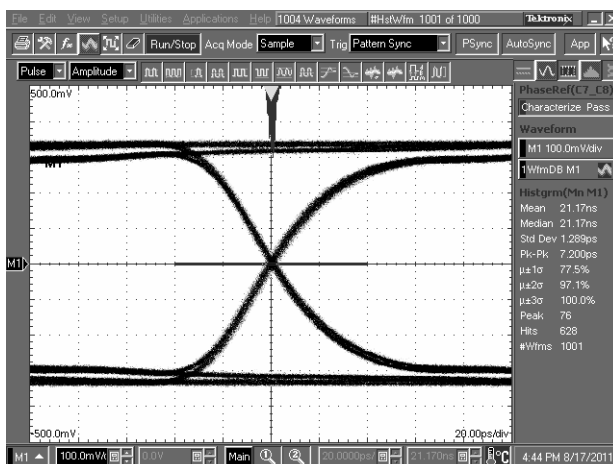

Figure 11. No Media; D3186 driving device directly

The following lab setups were used to collect typical performance data on FR4 and Cable media.

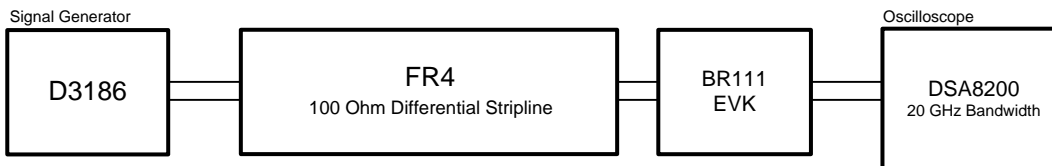

Figure 12. Equalization Test Setup for FR4

EQUALIZATION RESULTS:

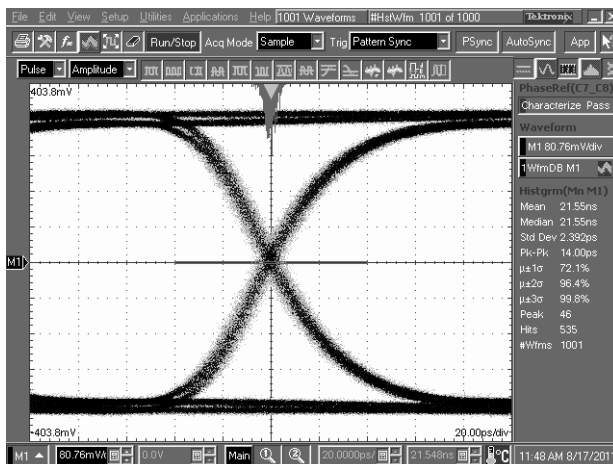

Figure 13. Equalization Performance with 30" of 4 mil FR4 using EQ setting 0x16

**EQUALIZATION RESULTS:**

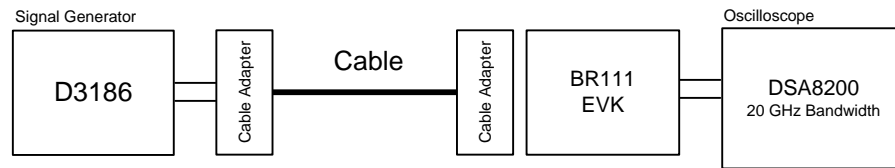

Figure 14. Equalization Test Setup for Cables

**CABLE TRANSMIT and RECEIVE RESULTS:**

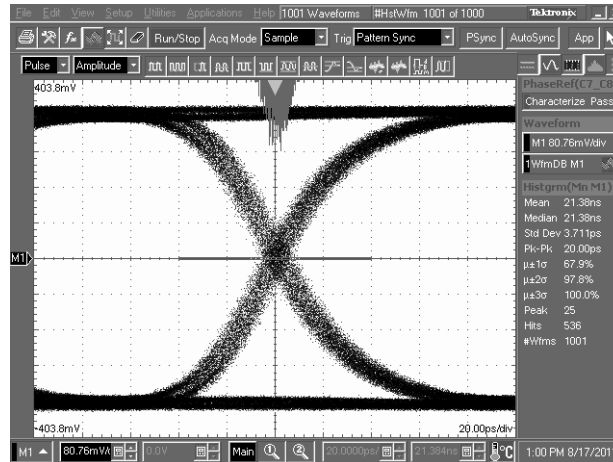

Figure 15. 8M 30AWG Cable Performance with 700mV Launch VOD and Rx EQ setting 0x0F

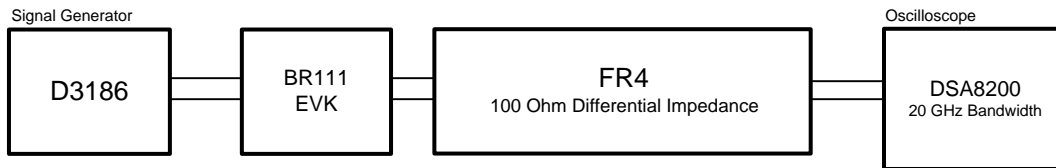

Figure 16. De-Emphasis Test Setup

**DE-EMPHASIS RESULTS:**

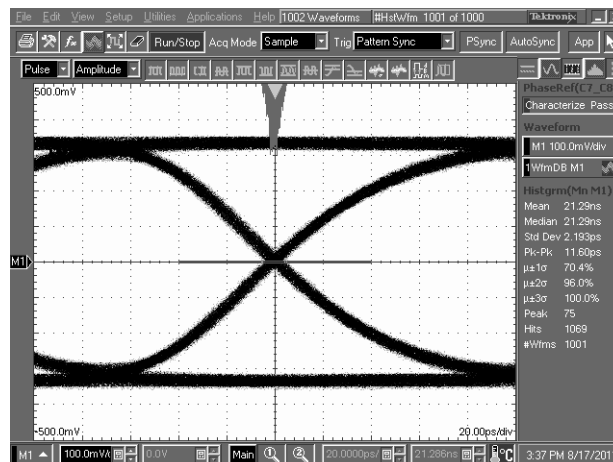

Figure 17. De-Emphasis Performance with 10" of 4 mil FR4 using DE setting 0x02

DE-EMPHASIS RESULTS:

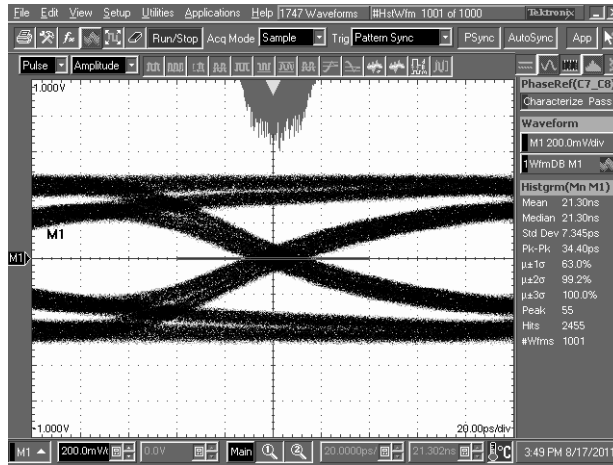

Figure 18. 10" of 4 mil FR4 Without De-Emphasis

## REVISION HISTORY

Changes from Revision B (April 2013) to Revision C	Page
• Changed layout of National Data Sheet to TI format .....	<a href="#">32</a>

**PACKAGING INFORMATION**

Orderable Device	Status (1)	Package Type	Package Drawing	Pins	Package Qty	Eco Plan (2)	Lead/Ball Finish	MSL Peak Temp (3)	Op Temp (°C)	Top-Side Markings (4)	Samples
DS64BR111SQ/NOPB	ACTIVE	WQFN	RTW	24	1000	Green (RoHS & no Sb/Br)	CU SN	Level-3-260C-168 HR	-40 to 85	64BR111	<a href="#">Samples</a>
DS64BR111SQE/NOPB	ACTIVE	WQFN	RTW	24	250	Green (RoHS & no Sb/Br)	CU SN	Level-3-260C-168 HR	-40 to 85	64BR111	<a href="#">Samples</a>

(1) The marketing status values are defined as follows:

**ACTIVE:** Product device recommended for new designs.

**LIFEBUY:** TI has announced that the device will be discontinued, and a lifetime-buy period is in effect.

**NRND:** Not recommended for new designs. Device is in production to support existing customers, but TI does not recommend using this part in a new design.

**PREVIEW:** Device has been announced but is not in production. Samples may or may not be available.

**OBSOLETE:** TI has discontinued the production of the device.

(2) Eco Plan - The planned eco-friendly classification: Pb-Free (RoHS), Pb-Free (RoHS Exempt), or Green (RoHS & no Sb/Br) - please check <http://www.ti.com/productcontent> for the latest availability information and additional product content details.

**TBD:** The Pb-Free/Green conversion plan has not been defined.

**Pb-Free (RoHS):** TI's terms "Lead-Free" or "Pb-Free" mean semiconductor products that are compatible with the current RoHS requirements for all 6 substances, including the requirement that lead not exceed 0.1% by weight in homogeneous materials. Where designed to be soldered at high temperatures, TI Pb-Free products are suitable for use in specified lead-free processes.

**Pb-Free (RoHS Exempt):** This component has a RoHS exemption for either 1) lead-based flip-chip solder bumps used between the die and package, or 2) lead-based die adhesive used between the die and leadframe. The component is otherwise considered Pb-Free (RoHS compatible) as defined above.

**Green (RoHS & no Sb/Br):** TI defines "Green" to mean Pb-Free (RoHS compatible), and free of Bromine (Br) and Antimony (Sb) based flame retardants (Br or Sb do not exceed 0.1% by weight in homogeneous material)

(3) MSL, Peak Temp. -- The Moisture Sensitivity Level rating according to the JEDEC industry standard classifications, and peak solder temperature.

(4) Multiple Top-Side Markings will be inside parentheses. Only one Top-Side Marking contained in parentheses and separated by a "~" will appear on a device. If a line is indented then it is a continuation of the previous line and the two combined represent the entire Top-Side Marking for that device.

**Important Information and Disclaimer:** The information provided on this page represents TI's knowledge and belief as of the date that it is provided. TI bases its knowledge and belief on information provided by third parties, and makes no representation or warranty as to the accuracy of such information. Efforts are underway to better integrate information from third parties. TI has taken and continues to take reasonable steps to provide representative and accurate information but may not have conducted destructive testing or chemical analysis on incoming materials and chemicals. TI and TI suppliers consider certain information to be proprietary, and thus CAS numbers and other limited information may not be available for release.

In no event shall TI's liability arising out of such information exceed the total purchase price of the TI part(s) at issue in this document sold by TI to Customer on an annual basis.

**TAPE AND REEL INFORMATION**

**QUADRANT ASSIGNMENTS FOR PIN 1 ORIENTATION IN TAPE**

\*All dimensions are nominal

Device	Package Type	Package Drawing	Pins	SPQ	Reel Diameter (mm)	Reel Width W1 (mm)	A0 (mm)	B0 (mm)	K0 (mm)	P1 (mm)	W (mm)	Pin1 Quadrant
DS64BR111SQ/NOPB	WQFN	RTW	24	1000	178.0	12.4	4.3	4.3	1.3	8.0	12.0	Q1
DS64BR111SQE/NOPB	WQFN	RTW	24	250	178.0	12.4	4.3	4.3	1.3	8.0	12.0	Q1

## TAPE AND REEL BOX DIMENSIONS



\*All dimensions are nominal

Device	Package Type	Package Drawing	Pins	SPQ	Length (mm)	Width (mm)	Height (mm)
DS64BR111SQ/NOPB	WQFN	RTW	24	1000	210.0	185.0	35.0
DS64BR111SQE/NOPB	WQFN	RTW	24	250	210.0	185.0	35.0

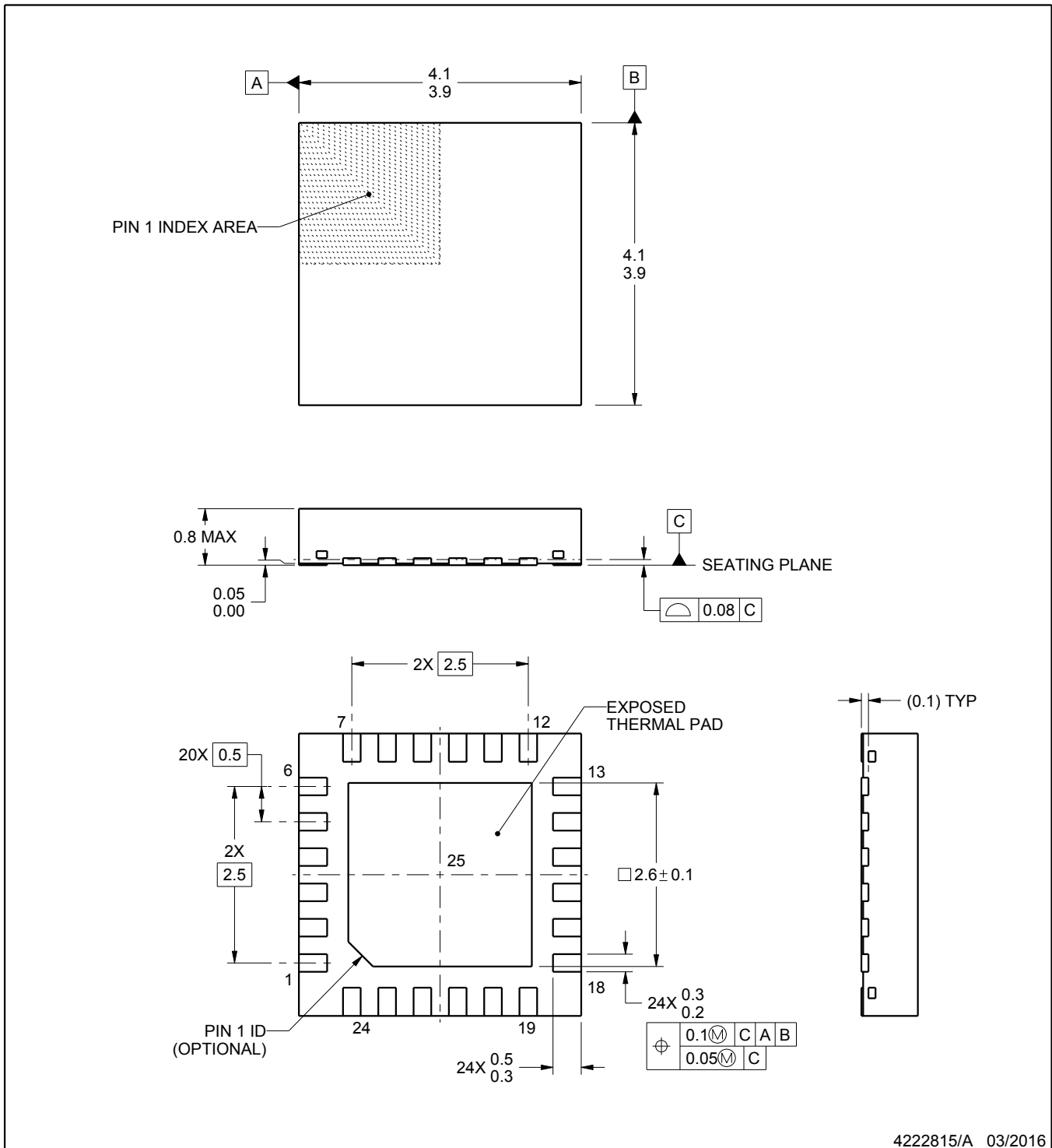
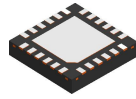

4222815/A 03/2016

NOTES:

1. All linear dimensions are in millimeters. Any dimensions in parenthesis are for reference only. Dimensioning and tolerancing per ASME Y14.5M.
2. This drawing is subject to change without notice.
3. The package thermal pad must be soldered to the printed circuit board for thermal and mechanical performance.

# EXAMPLE BOARD LAYOUT

RTW0024A

WQFN - 0.8 mm max height

PLASTIC QUAD FLATPACK - NO LEAD

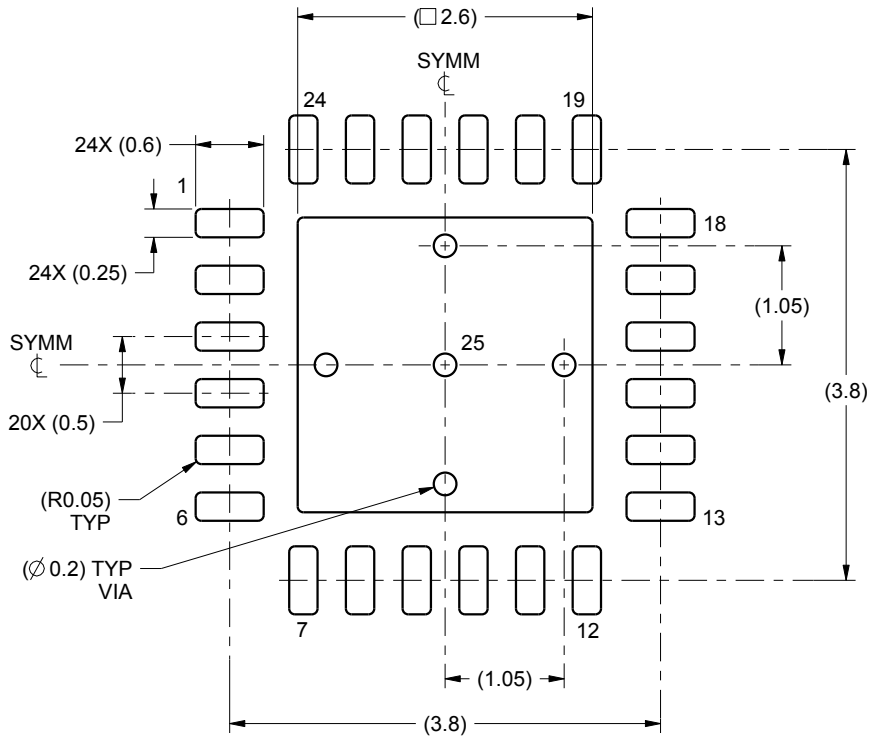

LAND PATTERN EXAMPLE  
SCALE:15X

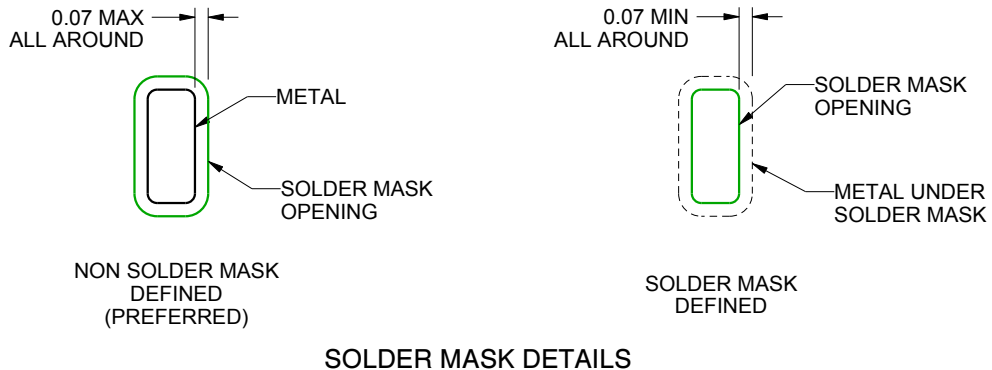

SOLDER MASK DETAILS

4222815/A 03/2016

NOTES: (continued)

4. This package is designed to be soldered to a thermal pad on the board. For more information, see Texas Instruments literature number SLUA271 ([www.ti.com/lit/sluea271](http://www.ti.com/lit/sluea271)).

# EXAMPLE STENCIL DESIGN

RTW0024A

WQFN - 0.8 mm max height

PLASTIC QUAD FLATPACK - NO LEAD

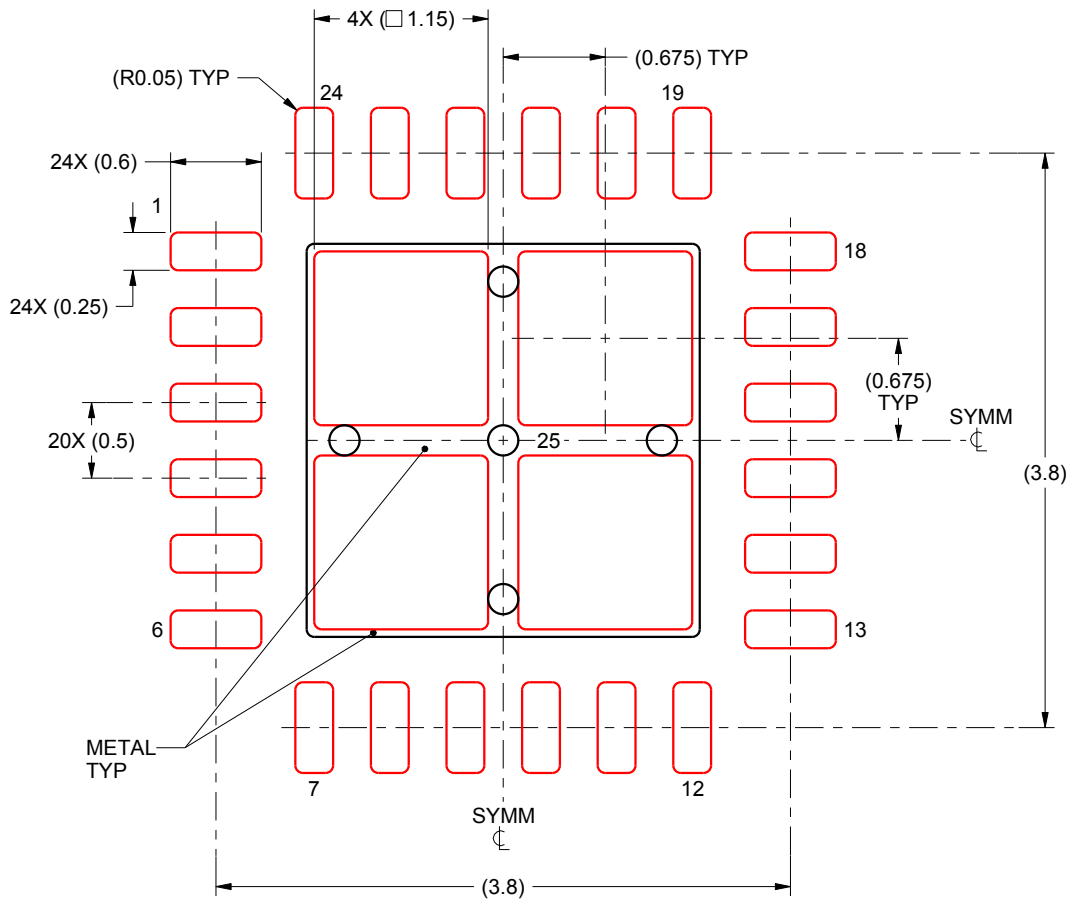

**SOLDER PASTE EXAMPLE**  
BASED ON 0.125 mm THICK STENCIL

EXPOSED PAD 25:  
78% PRINTED SOLDER COVERAGE BY AREA UNDER PACKAGE  
SCALE:20X

4222815/A 03/2016

NOTES: (continued)

5. Laser cutting apertures with trapezoidal walls and rounded corners may offer better paste release. IPC-7525 may have alternate design recommendations.

## IMPORTANT NOTICE

Texas Instruments Incorporated (TI) reserves the right to make corrections, enhancements, improvements and other changes to its semiconductor products and services per JESD46, latest issue, and to discontinue any product or service per JESD48, latest issue. Buyers should obtain the latest relevant information before placing orders and should verify that such information is current and complete.

TI's published terms of sale for semiconductor products (<http://www.ti.com/sc/docs/stdterms.htm>) apply to the sale of packaged integrated circuit products that TI has qualified and released to market. Additional terms may apply to the use or sale of other types of TI products and services.

Reproduction of significant portions of TI information in TI data sheets is permissible only if reproduction is without alteration and is accompanied by all associated warranties, conditions, limitations, and notices. TI is not responsible or liable for such reproduced documentation. Information of third parties may be subject to additional restrictions. Resale of TI products or services with statements different from or beyond the parameters stated by TI for that product or service voids all express and any implied warranties for the associated TI product or service and is an unfair and deceptive business practice. TI is not responsible or liable for any such statements.

Buyers and others who are developing systems that incorporate TI products (collectively, "Designers") understand and agree that Designers remain responsible for using their independent analysis, evaluation and judgment in designing their applications and that Designers have full and exclusive responsibility to assure the safety of Designers' applications and compliance of their applications (and of all TI products used in or for Designers' applications) with all applicable regulations, laws and other applicable requirements. Designer represents that, with respect to their applications, Designer has all the necessary expertise to create and implement safeguards that (1) anticipate dangerous consequences of failures, (2) monitor failures and their consequences, and (3) lessen the likelihood of failures that might cause harm and take appropriate actions. Designer agrees that prior to using or distributing any applications that include TI products, Designer will thoroughly test such applications and the functionality of such TI products as used in such applications.

TI's provision of technical, application or other design advice, quality characterization, reliability data or other services or information, including, but not limited to, reference designs and materials relating to evaluation modules, (collectively, "TI Resources") are intended to assist designers who are developing applications that incorporate TI products; by downloading, accessing or using TI Resources in any way, Designer (individually or, if Designer is acting on behalf of a company, Designer's company) agrees to use any particular TI Resource solely for this purpose and subject to the terms of this Notice.

TI's provision of TI Resources does not expand or otherwise alter TI's applicable published warranties or warranty disclaimers for TI products, and no additional obligations or liabilities arise from TI providing such TI Resources. TI reserves the right to make corrections, enhancements, improvements and other changes to its TI Resources. TI has not conducted any testing other than that specifically described in the published documentation for a particular TI Resource.

Designer is authorized to use, copy and modify any individual TI Resource only in connection with the development of applications that include the TI product(s) identified in such TI Resource. NO OTHER LICENSE, EXPRESS OR IMPLIED, BY ESTOPPEL OR OTHERWISE TO ANY OTHER TI INTELLECTUAL PROPERTY RIGHT, AND NO LICENSE TO ANY TECHNOLOGY OR INTELLECTUAL PROPERTY RIGHT OF TI OR ANY THIRD PARTY IS GRANTED HEREIN, including but not limited to any patent right, copyright, mask work right, or other intellectual property right relating to any combination, machine, or process in which TI products or services are used. Information regarding or referencing third-party products or services does not constitute a license to use such products or services, or a warranty or endorsement thereof. Use of TI Resources may require a license from a third party under the patents or other intellectual property of the third party, or a license from TI under the patents or other intellectual property of TI.

TI RESOURCES ARE PROVIDED "AS IS" AND WITH ALL FAULTS. TI DISCLAIMS ALL OTHER WARRANTIES OR REPRESENTATIONS, EXPRESS OR IMPLIED, REGARDING RESOURCES OR USE THEREOF, INCLUDING BUT NOT LIMITED TO ACCURACY OR COMPLETENESS, TITLE, ANY EPIDEMIC FAILURE WARRANTY AND ANY IMPLIED WARRANTIES OF MERCHANTABILITY, FITNESS FOR A PARTICULAR PURPOSE, AND NON-INFRINGEMENT OF ANY THIRD PARTY INTELLECTUAL PROPERTY RIGHTS. TI SHALL NOT BE LIABLE FOR AND SHALL NOT DEFEND OR INDEMNIFY DESIGNER AGAINST ANY CLAIM, INCLUDING BUT NOT LIMITED TO ANY INFRINGEMENT CLAIM THAT RELATES TO OR IS BASED ON ANY COMBINATION OF PRODUCTS EVEN IF DESCRIBED IN TI RESOURCES OR OTHERWISE. IN NO EVENT SHALL TI BE LIABLE FOR ANY ACTUAL, DIRECT, SPECIAL, COLLATERAL, INDIRECT, PUNITIVE, INCIDENTAL, CONSEQUENTIAL OR EXEMPLARY DAMAGES IN CONNECTION WITH OR ARISING OUT OF TI RESOURCES OR USE THEREOF, AND REGARDLESS OF WHETHER TI HAS BEEN ADVISED OF THE POSSIBILITY OF SUCH DAMAGES.

Unless TI has explicitly designated an individual product as meeting the requirements of a particular industry standard (e.g., ISO/TS 16949 and ISO 26262), TI is not responsible for any failure to meet such industry standard requirements.

Where TI specifically promotes products as facilitating functional safety or as compliant with industry functional safety standards, such products are intended to help enable customers to design and create their own applications that meet applicable functional safety standards and requirements. Using products in an application does not by itself establish any safety features in the application. Designers must ensure compliance with safety-related requirements and standards applicable to their applications. Designer may not use any TI products in life-critical medical equipment unless authorized officers of the parties have executed a special contract specifically governing such use. Life-critical medical equipment is medical equipment where failure of such equipment would cause serious bodily injury or death (e.g., life support, pacemakers, defibrillators, heart pumps, neurostimulators, and implantables). Such equipment includes, without limitation, all medical devices identified by the U.S. Food and Drug Administration as Class III devices and equivalent classifications outside the U.S.

TI may expressly designate certain products as completing a particular qualification (e.g., Q100, Military Grade, or Enhanced Product). Designers agree that it has the necessary expertise to select the product with the appropriate qualification designation for their applications and that proper product selection is at Designers' own risk. Designers are solely responsible for compliance with all legal and regulatory requirements in connection with such selection.

Designer will fully indemnify TI and its representatives against any damages, costs, losses, and/or liabilities arising out of Designer's non-compliance with the terms and provisions of this Notice.

## Looking for pricing, stock, or lifecycle information?

Click below to explore more details on WIN SOURCE:

 [View DS64BR111SQE/NOPB on WIN SOURCE](#)

 [Texas Instruments](#) Information

## Optimize Your Supply Chain with WIN SOURCE Solutions

-  Global Sourcing Solution
-  Obsolete Management
-  Cost Control Management
-  Shortage Management
-  Alternative Solution
-  Excess Inventory Management