

Features

- High Performance, Low Power 32-Bit Atmel® AVR® Microcontroller
 - Compact Single-cycle RISC Instruction Set Including DSP Instruction Set
 - Read-Modify-Write Instructions and Atomic Bit Manipulation
 - Performing 1.49 DMIPS / MHz
 - Up to 91 DMIPS Running at 66 MHz from Flash (1 Wait-State)
 - Up to 49 DMIPS Running at 33MHz from Flash (0 Wait-State)
 - Memory Protection Unit
- Multi-hierarchy Bus System
 - High-Performance Data Transfers on Separate Buses for Increased Performance
 - 15 Peripheral DMA Channels Improves Speed for Peripheral Communication
- Internal High-Speed Flash
 - 512K Bytes, 256K Bytes, 128K Bytes Versions
 - Single Cycle Access up to 33 MHz
 - Prefetch Buffer Optimizing Instruction Execution at Maximum Speed
 - 4ms Page Programming Time and 8ms Full-Chip Erase Time
 - 100,000 Write Cycles, 15-year Data Retention Capability
 - Flash Security Locks and User Defined Configuration Area
- Internal High-Speed SRAM, Single-Cycle Access at Full Speed
 - 64K Bytes (512KB and 256KB Flash), 32K Bytes (128KB Flash)
- External Memory Interface on AT32UC3A0 Derivatives
 - SDRAM / SRAM Compatible Memory Bus (16-bit Data and 24-bit Address Buses)
- Interrupt Controller
 - Autovectorized Low Latency Interrupt Service with Programmable Priority
- System Functions
 - Power and Clock Manager Including Internal RC Clock and One 32KHz Oscillator
 - Two Multipurpose Oscillators and Two Phase-Lock-Loop (PLL) allowing Independent CPU Frequency from USB Frequency
 - Watchdog Timer, Real-Time Clock Timer
- Universal Serial Bus (USB)
 - Device 2.0 Full Speed and On-The-Go (OTG) Low Speed and Full Speed
 - Flexible End-Point Configuration and Management with Dedicated DMA Channels
 - On-chip Transceivers Including Pull-Ups
- Ethernet MAC 10/100 Mbps interface
 - 802.3 Ethernet Media Access Controller
 - Supports Media Independent Interface (MII) and Reduced MII (RMII)
- One Three-Channel 16-bit Timer/Counter (TC)
 - Three External Clock Inputs, PWM, Capture and Various Counting Capabilities
- One 7-Channel 16-bit Pulse Width Modulation Controller (PWM)
- Four Universal Synchronous/Asynchronous Receiver/Transmitters (USART)
 - Independent Baudrate Generator, Support for SPI, IrDA and ISO7816 interfaces
 - Support for Hardware Handshaking, RS485 Interfaces and Modem Line
- Two Master/Slave Serial Peripheral Interfaces (SPI) with Chip Select Signals
- One Synchronous Serial Protocol Controller
 - Supports I2S and Generic Frame-Based Protocols
- One Master/Slave Two-Wire Interface (TWI), 400kbit/s I2C-compatible
- One 8-channel 10-bit Analog-To-Digital Converter
- 16-bit Stereo Audio Bitstream
 - Sample Rate Up to 50 KHz



32-Bit Atmel AVR Microcontroller

AT32UC3A0512
AT32UC3A0256
AT32UC3A0128
AT32UC3A1512
AT32UC3A1256
AT32UC3A1128

Summary

32058KS-AVR32-01/12



- **On-Chip Debug System (JTAG interface)**
 - Nexus Class 2+, Runtime Control, Non-Intrusive Data and Program Trace
- **100-pin TQFP (69 GPIO pins), 144-pin LQFP (109 GPIO pins) , 144 BGA (109 GPIO pins)**
- **5V Input Tolerant I/Os**
- **Single 3.3V Power Supply or Dual 1.8V-3.3V Power Supply**

1. Description

The AT32UC3A is a complete System-On-Chip microcontroller based on the AVR32 UC RISC processor running at frequencies up to 66 MHz. AVR32 UC is a high-performance 32-bit RISC microprocessor core, designed for cost-sensitive embedded applications, with particular emphasis on low power consumption, high code density and high performance.

The processor implements a Memory Protection Unit (MPU) and a fast and flexible interrupt controller for supporting modern operating systems and real-time operating systems. Higher computation capabilities are achievable using a rich set of DSP instructions.

The AT32UC3A incorporates on-chip Flash and SRAM memories for secure and fast access. For applications requiring additional memory, an external memory interface is provided on AT32UC3A0 derivatives.

The Peripheral Direct Memory Access controller (PDCA) enables data transfers between peripherals and memories without processor involvement. PDCA drastically reduces processing overhead when transferring continuous and large data streams between modules within the MCU.

The PowerManager improves design flexibility and security: the on-chip Brown-Out Detector monitors the power supply, the CPU runs from the on-chip RC oscillator or from one of external oscillator sources, a Real-Time Clock and its associated timer keeps track of the time.

The Timer/Counter includes three identical 16-bit timer/counter channels. Each channel can be independently programmed to perform frequency measurement, event counting, interval measurement, pulse generation, delay timing and pulse width modulation.

The PWM modules provides seven independent channels with many configuration options including polarity, edge alignment and waveform non overlap control. One PWM channel can trigger ADC conversions for more accurate close loop control implementations.

The AT32UC3A also features many communication interfaces for communication intensive applications. In addition to standard serial interfaces like UART, SPI or TWI, other interfaces like flexible Synchronous Serial Controller, USB and Ethernet MAC are available.

The Synchronous Serial Controller provides easy access to serial communication protocols and audio standards like I2S.

The Full-Speed USB 2.0 Device interface supports several USB Classes at the same time thanks to the rich End-Point configuration. The On-The-GO (OTG) Host interface allows device like a USB Flash disk or a USB printer to be directly connected to the processor.

The media-independent interface (MII) and reduced MII (RMII) 10/100 Ethernet MAC module provides on-chip solutions for network-connected devices.

AT32UC3A integrates a class 2+ Nexus 2.0 On-Chip Debug (OCD) System, with non-intrusive real-time trace, full-speed read/write memory access in addition to basic runtime control.

2. Configuration Summary

The table below lists all AT32UC3A memory and package configurations:

Device	Flash	SRAM	Ext. Bus Interface	Ethernet MAC	Package
AT32UC3A0512	512 Kbytes	64 Kbytes	yes	yes	144 pin LQFP 144 pin BGA
AT32UC3A0256	256 Kbytes	64 Kbytes	yes	yes	144 pin LQFP 144 pin BGA
AT32UC3A0128	128 Kbytes	32 Kbytes	yes	yes	144 pin LQFP 144 pin BGA
AT32UC3A1512	512 Kbytes	64 Kbytes	no	yes	100 pin TQFP
AT32UC3A1256	256 Kbytes	64 Kbytes	no	yes	100 pin TQFP
AT32UC3A1128	128 Kbytes	32 Kbytes	no	yes	100 pin TQFP

3. Abbreviations

- GCLK: Power Manager Generic Clock
- GPIO: General Purpose Input/Output
- HSB: High Speed Bus
- MPU: Memory Protection Unit
- OCD: On Chip Debug
- PB: Peripheral Bus
- PDCA: Peripheral Direct Memory Access Controller (PDC) version A
- USBB: USB On-The-GO Controller version B

4. Blockdiagram

Figure 4-1. Blockdiagram

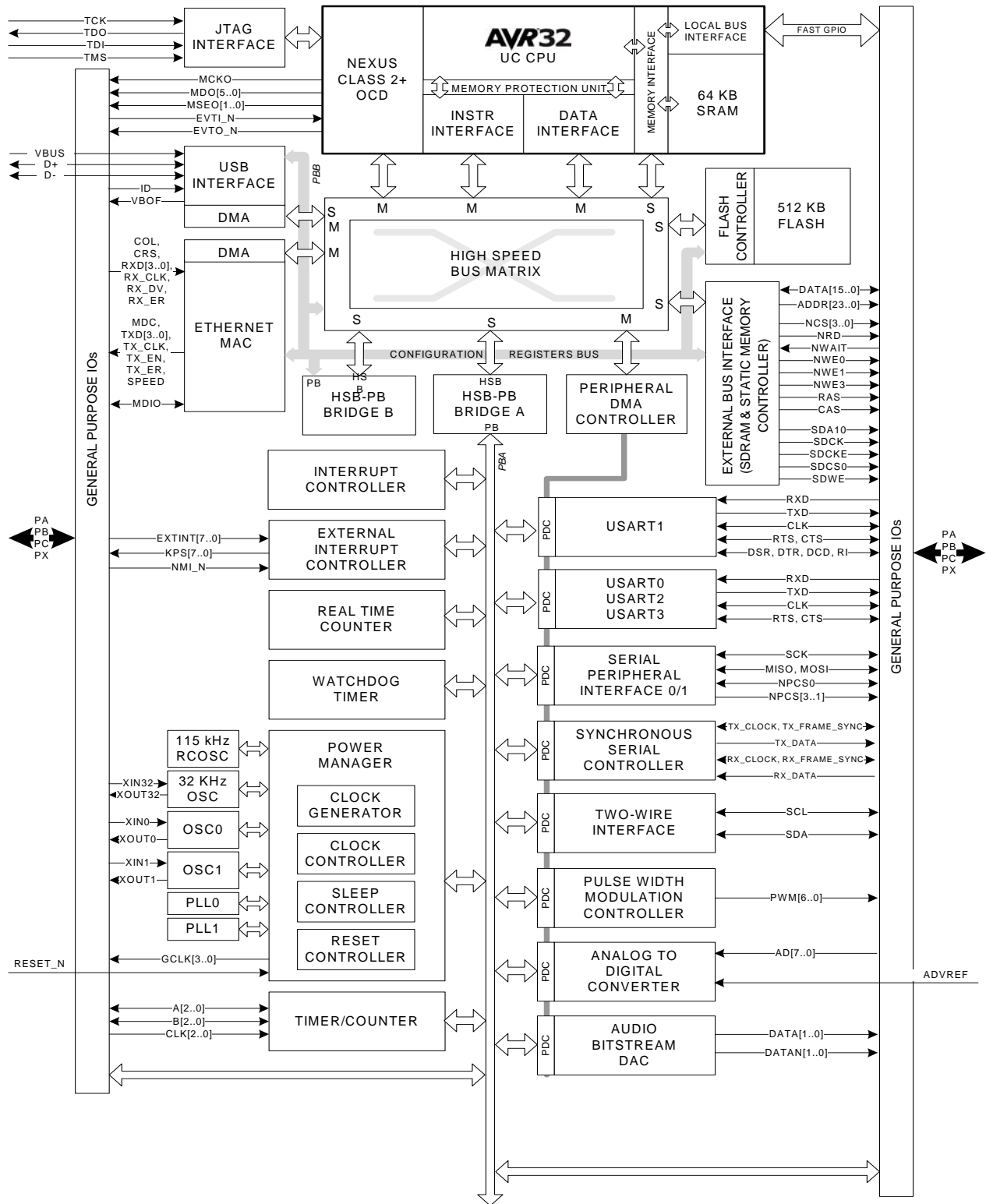

4.1 Processor and architecture

4.1.1 AVR32 UC CPU

- 32-bit load/store AVR32A RISC architecture.
 - 15 general-purpose 32-bit registers.
 - 32-bit Stack Pointer, Program Counter and Link Register reside in register file.
 - Fully orthogonal instruction set.
 - Privileged and unprivileged modes enabling efficient and secure Operating Systems.
 - Innovative instruction set together with variable instruction length ensuring industry leading code density.
 - DSP extension with saturating arithmetic, and a wide variety of multiply instructions.
- 3 stage pipeline allows one instruction per clock cycle for most instructions.
 - Byte, half-word, word and double word memory access.
 - Multiple interrupt priority levels.
- MPU allows for operating systems with memory protection.

4.1.2 Debug and Test system

- IEEE1149.1 compliant JTAG and boundary scan
- Direct memory access and programming capabilities through JTAG interface
- Extensive On-Chip Debug features in compliance with IEEE-ISTO 5001-2003 (Nexus 2.0) Class 2+
 - Low-cost NanoTrace supported.
- Auxiliary port for high-speed trace information
- Hardware support for 6 Program and 2 data breakpoints
- Unlimited number of software breakpoints supported
- Advanced Program, Data, Ownership, and Watchpoint trace supported

4.1.3 Peripheral DMA Controller

- Transfers from/to peripheral to/from any memory space without intervention of the processor.
- Next Pointer Support, forbids strong real-time constraints on buffer management.
- Fifteen channels
 - Two for each USART
 - Two for each Serial Synchronous Controller
 - Two for each Serial Peripheral Interface
 - One for each ADC
 - Two for each TWI Interface

4.1.4 Bus system

- High Speed Bus (HSB) matrix with 6 Masters and 6 Slaves handled
 - Handles Requests from the CPU Data Fetch, CPU Instruction Fetch, PDCA, USBB, Ethernet Controller, CPU SAB, and to internal Flash, internal SRAM, Peripheral Bus A, Peripheral Bus B, EBI.
 - Round-Robin Arbitration (three modes supported: no default master, last accessed default master, fixed default master)
 - Burst Breaking with Slot Cycle Limit
 - One Address Decoder Provided per Master

- **Peripheral Bus A able to run on at divided bus speeds compared to the High Speed Bus**

[Figure 4-1](#) gives an overview of the bus system. All modules connected to the same bus use the same clock, but the clock to each module can be individually shut off by the Power Manager. The figure identifies the number of master and slave interfaces of each module connected to the High Speed Bus, and which DMA controller is connected to which peripheral.

5. Signals Description

The following table gives details on the signal name classified by peripheral

The signals are multiplexed with GPIO pins as described in "[Peripheral Multiplexing on I/O lines](#)" on page 31.

Table 5-1. Signal Description List

Signal Name	Function	Type	Active Level	Comments
Power				
VDDPLL	Power supply for PLL	Power Input		1.65V to 1.95 V
VDDCORE	Core Power Supply	Power Input		1.65V to 1.95 V
VDDIO	I/O Power Supply	Power Input		3.0V to 3.6V
VDDANA	Analog Power Supply	Power Input		3.0V to 3.6V
VDDIN	Voltage Regulator Input Supply	Power Input		3.0V to 3.6V
VDDOUT	Voltage Regulator Output	Power Output		1.65V to 1.95 V
GNDANA	Analog Ground	Ground		
GND	Ground	Ground		
Clocks, Oscillators, and PLL's				
XIN0, XIN1, XIN32	Crystal 0, 1, 32 Input	Analog		
XOUT0, XOUT1, XOUT32	Crystal 0, 1, 32 Output	Analog		
JTAG				
TCK	Test Clock	Input		
TDI	Test Data In	Input		
TDO	Test Data Out	Output		
TMS	Test Mode Select	Input		
Auxiliary Port - AUX				
MCKO	Trace Data Output Clock	Output		
MDO0 - MDO5	Trace Data Output	Output		

Table 5-1. Signal Description List

Signal Name	Function	Type	Active Level	Comments
MSEO0 - MSEO1	Trace Frame Control	Output		
EVTI_N	Event In	Output	Low	
EVTO_N	Event Out	Output	Low	
Power Manager - PM				
GCLK0 - GCLK3	Generic Clock Pins	Output		
RESET_N	Reset Pin	Input	Low	
Real Time Counter - RTC				
RTC_CLOCK	RTC clock	Output		
Watchdog Timer - WDT				
WDTEXT	External Watchdog Pin	Output		
External Interrupt Controller - EIC				
EXTINT0 - EXTINT7	External Interrupt Pins	Input		
KPS0 - KPS7	Keypad Scan Pins	Output		
NMI_N	Non-Maskable Interrupt Pin	Input	Low	
Ethernet MAC - MACB				
COL	Collision Detect	Input		
CRS	Carrier Sense and Data Valid	Input		
MDC	Management Data Clock	Output		
MDIO	Management Data Input/Output	I/O		
RXD0 - RXD3	Receive Data	Input		
RX_CLK	Receive Clock	Input		
RX_DV	Receive Data Valid	Input		
RX_ER	Receive Coding Error	Input		
SPEED	Speed			
TXD0 - TXD3	Transmit Data	Output		
TX_CLK	Transmit Clock or Reference Clock	Output		
TX_EN	Transmit Enable	Output		
TX_ER	Transmit Coding Error	Output		

Table 5-1. Signal Description List

Signal Name	Function	Type	Active Level	Comments
External Bus Interface - HEBI				
ADDR0 - ADDR23	Address Bus	Output		
CAS	Column Signal	Output	Low	
DATA0 - DATA15	Data Bus	I/O		
NCS0 - NCS3	Chip Select	Output	Low	
NRD	Read Signal	Output	Low	
NWAIT	External Wait Signal	Input	Low	
NWE0	Write Enable 0	Output	Low	
NWE1	Write Enable 1	Output	Low	
NWE3	Write Enable 3	Output	Low	
RAS	Row Signal	Output	Low	
SDA10	SDRAM Address 10 Line	Output		
SDCK	SDRAM Clock	Output		
SDCKE	SDRAM Clock Enable	Output		
SDCS0	SDRAM Chip Select	Output	Low	
SDWE	SDRAM Write Enable	Output	Low	
General Purpose Input/Output 2 - GPIOA, GPIOB, GPIOC				
P0 - P31	Parallel I/O Controller GPIOA	I/O		
P0 - P31	Parallel I/O Controller GPIOB	I/O		
P0 - P5	Parallel I/O Controller GPIOC	I/O		
P0 - P31	Parallel I/O Controller GPIOX	I/O		
Serial Peripheral Interface - SPI0, SPI1				
MISO	Master In Slave Out	I/O		
MOSI	Master Out Slave In	I/O		
NPCS0 - NPCS3	SPI Peripheral Chip Select	I/O	Low	
SCK	Clock	Output		
Synchronous Serial Controller - SSC				
RX_CLOCK	SSC Receive Clock	I/O		

Table 5-1. Signal Description List

Signal Name	Function	Type	Active Level	Comments
RX_DATA	SSC Receive Data	Input		
RX_FRAME_SYNC	SSC Receive Frame Sync	I/O		
TX_CLOCK	SSC Transmit Clock	I/O		
TX_DATA	SSC Transmit Data	Output		
TX_FRAME_SYNC	SSC Transmit Frame Sync	I/O		
Timer/Counter - TIMER				
A0	Channel 0 Line A	I/O		
A1	Channel 1 Line A	I/O		
A2	Channel 2 Line A	I/O		
B0	Channel 0 Line B	I/O		
B1	Channel 1 Line B	I/O		
B2	Channel 2 Line B	I/O		
CLK0	Channel 0 External Clock Input	Input		
CLK1	Channel 1 External Clock Input	Input		
CLK2	Channel 2 External Clock Input	Input		
Two-wire Interface - TWI				
SCL	Serial Clock	I/O		
SDA	Serial Data	I/O		
Universal Synchronous Asynchronous Receiver Transmitter - USART0, USART1, USART2, USART3				
CLK	Clock	I/O		
CTS	Clear To Send	Input		
DCD	Data Carrier Detect			Only USART1
DSR	Data Set Ready			Only USART1
DTR	Data Terminal Ready			Only USART1
RI	Ring Indicator			Only USART1
RTS	Request To Send	Output		
RXD	Receive Data	Input		
TXD	Transmit Data	Output		

Table 5-1. Signal Description List

Signal Name	Function	Type	Active Level	Comments
Analog to Digital Converter - ADC				
AD0 - AD7	Analog input pins	Analog input		
ADVREF	Analog positive reference voltage input	Analog input		2.6 to 3.6V
Pulse Width Modulator - PWM				
PWM0 - PWM6	PWM Output Pins	Output		
Universal Serial Bus Device - USB				
DDM	USB Device Port Data -	Analog		
DDP	USB Device Port Data +	Analog		
VBUS	USB VBUS Monitor and OTG Negotiation	Analog Input		
USBID	ID Pin of the USB Bus	Input		
USB_VBOF	USB VBUS On/off: bus power control port	output		
Audio Bitstream DAC (ABDAC)				
DATA0-DATA1	D/A Data out	Output		
DATAN0-DATAN1	D/A Data inverted out	Output		

6. Package and Pinout

The device pins are multiplexed with peripheral functions as described in "Peripheral Multiplexing on I/O lines" on page 31.

Figure 6-1. TQFP100 Pinout

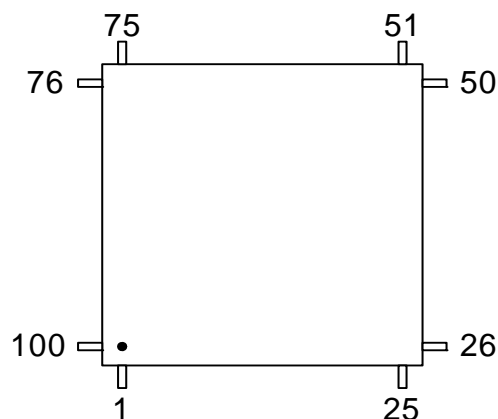

Table 6-1. TQFP100 Package Pinout

1	PB20	26	PA05	51	PA21	76	PB08
2	PB21	27	PA06	52	PA22	77	PB09
3	PB22	28	PA07	53	PA23	78	PB10
4	VDDIO	29	PA08	54	PA24	79	VDDIO
5	GND	30	PA09	55	PA25	80	GND
6	PB23	31	PA10	56	PA26	81	PB11
7	PB24	32	N/C	57	PA27	82	PB12
8	PB25	33	PA11	58	PA28	83	PA29
9	PB26	34	VDDCORE	59	VDDANA	84	PA30
10	PB27	35	GND	60	ADVREF	85	PC02
11	VDDOUT	36	PA12	61	GNDANA	86	PC03
12	VDDIN	37	PA13	62	VDDPLL	87	PB13
13	GND	38	VDDCORE	63	PC00	88	PB14
14	PB28	39	PA14	64	PC01	89	TMS
15	PB29	40	PA15	65	PB00	90	TCK
16	PB30	41	PA16	66	PB01	91	TDO
17	PB31	42	PA17	67	VDDIO	92	TDI
18	RESET_N	43	PA18	68	VDDIO	93	PC04
19	PA00	44	PA19	69	GND	94	PC05
20	PA01	45	PA20	70	PB02	95	PB15
21	GND	46	VBUS	71	PB03	96	PB16
22	VDDCORE	47	VDDIO	72	PB04	97	VDDCORE

Table 6-1. TQFP100 Package Pinout

23	PA02	48	DM	73	PB05	98	PB17
24	PA03	49	DP	74	PB06	99	PB18
25	PA04	50	GND	75	PB07	100	PB19

Figure 6-2. LQFP144 Pinout

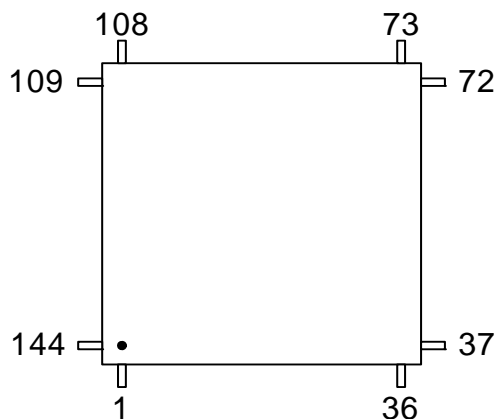

Table 6-2. VQFP144 Package Pinout

1	PX00	37	GND	73	PA21	109	GND
2	PX01	38	PX10	74	PA22	110	PX30
3	PB20	39	PA05	75	PA23	111	PB08
4	PX02	40	PX11	76	PA24	112	PX31
5	PB21	41	PA06	77	PA25	113	PB09
6	PB22	42	PX12	78	PA26	114	PX32
7	VDDIO	43	PA07	79	PA27	115	PB10
8	GND	44	PX13	80	PA28	116	VDDIO
9	PB23	45	PA08	81	VDDANA	117	GND
10	PX03	46	PX14	82	ADVREF	118	PX33
11	PB24	47	PA09	83	GNDANA	119	PB11
12	PX04	48	PA10	84	VDDPLL	120	PX34
13	PB25	49	N/C	85	PC00	121	PB12
14	PB26	50	PA11	86	PC01	122	PA29
15	PB27	51	VDDCORE	87	PX20	123	PA30
16	VDDOUT	52	GND	88	PB00	124	PC02
17	VDDIN	53	PA12	89	PX21	125	PC03
18	GND	54	PA13	90	PB01	126	PB13
19	PB28	55	VDDCORE	91	PX22	127	PB14
20	PB29	56	PA14	92	VDDIO	128	TMS
21	PB30	57	PA15	93	VDDIO	129	TCK

Table 6-2. VQFP144 Package Pinout

22	PB31	58	PA16	94	GND	130	TDO
23	RESET_N	59	PX15	95	PX23	131	TDI
24	PX05	60	PA17	96	PB02	132	PC04
25	PA00	61	PX16	97	PX24	133	PC05
26	PX06	62	PA18	98	PB03	134	PB15
27	PA01	63	PX17	99	PX25	135	PX35
28	GND	64	PA19	100	PB04	136	PB16
29	VDDCORE	65	PX18	101	PX26	137	PX36
30	PA02	66	PA20	102	PB05	138	VDDCORE
31	PX07	67	PX19	103	PX27	139	PB17
32	PA03	68	VBUS	104	PB06	140	PX37
33	PX08	69	VDDIO	105	PX28	141	PB18
34	PA04	70	DM	106	PB07	142	PX38
35	PX09	71	DP	107	PX29	143	PB19
36	VDDIO	72	GND	108	VDDIO	144	PX39

Figure 6-3. BGA144 Pinout

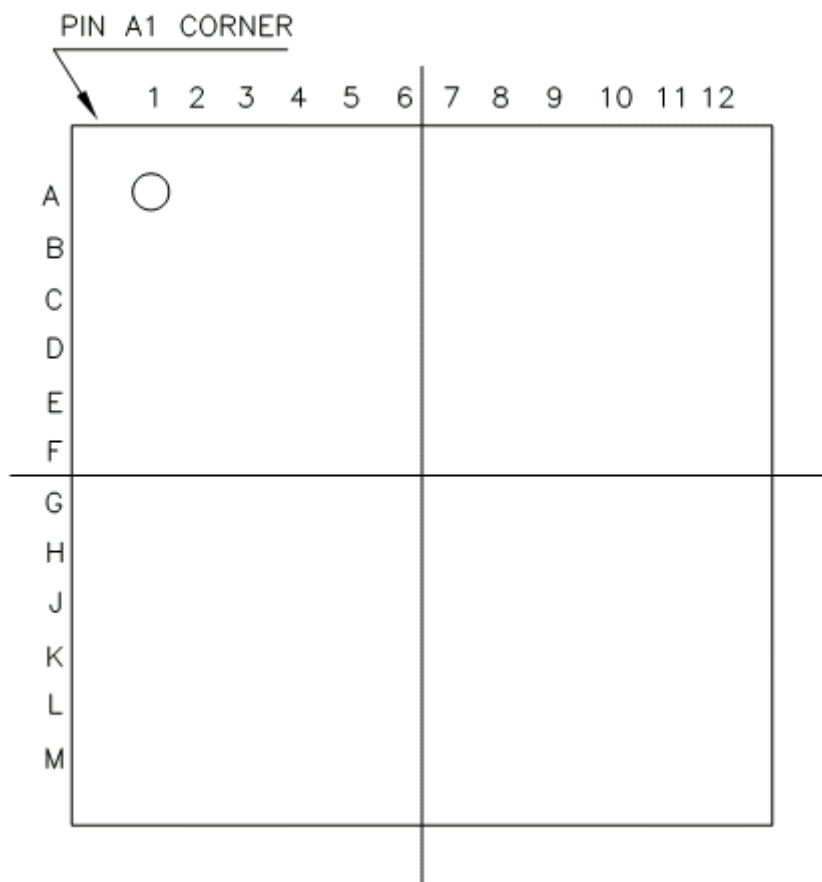

Table 6-3. BGA144 Package Pinout A1..M8

	1	2	3	4	5	6	7	8
A	VDDIO	PB07	PB05	PB02	PB03	PB01	PC00	PA28
B	PB08	GND	PB06	PB04	VDDIO	PB00	PC01	VDDPLL
C	PB09	PX33	PA29	PC02	PX28	PX26	PX22	PX21
D	PB11	PB13	PB12	PX30	PX29	PX25	PX24	PX20
E	PB10	VDDIO	PX32	PX31	VDDIO	PX27	PX23	VDDANA
F	PA30	PB14	PX34	PB16	TCK	GND	GND	PX16
G	TMS	PC03	PX36	PX35	PX37	GND	GND	PA16
H	TDO	VDDCORE	PX38	PX39	VDDIO	PA01	PA10	VDDCORE
J	TDI	PB17	PB15	PX00	PX01	PA00	PA03	PA04
K	PC05	PC04	PB19	PB20	PX02	PB29	PB30	PA02
L	PB21	GND	PB18	PB24	VDDOUT	PX04	PB31	VDDIN
M	PB22	PB23	PB25	PB26	PX03	PB27	PB28	RESET_N

Table 6-4. BGA144 Package Pinout A9..M12

	9	10	11	12
A	PA26	PA25	PA24	PA23
B	PA27	PA21	GND	PA22
C	ADVREF	GNDANA	PX19	PA19
D	PA18	PA20	DP	DM
E	PX18	PX17	VDDIO	VBUS
F	PA17	PX15	PA15	PA14
G	PA13	PA12	PA11	NC
H	PX11	PA08	VDDCORE	VDDCORE
J	PX14	PA07	PX13	PA09
K	PX08	GND	PA05	PX12
L	PX06	PX10	GND	PA06
M	PX05	PX07	PX09	VDDIO

Note: NC is not connected.

7. Power Considerations

7.1 Power Supplies

The AT32UC3A has several types of power supply pins:

- **VDDIO:** Powers I/O lines. Voltage is 3.3V nominal.
- **VDDANA:** Powers the ADC Voltage is 3.3V nominal.
- **VDDIN:** Input voltage for the voltage regulator. Voltage is 3.3V nominal.
- **VDDCORE:** Powers the core, memories, and peripherals. Voltage is 1.8V nominal.
- **VDDPLL:** Powers the PLL. Voltage is 1.8V nominal.

The ground pins GND are common to VDDCORE, VDDIO, VDDPLL. The ground pin for VDDANA is GNDANA.

Refer to ["Power Consumption" on page 44](#) for power consumption on the various supply pins.

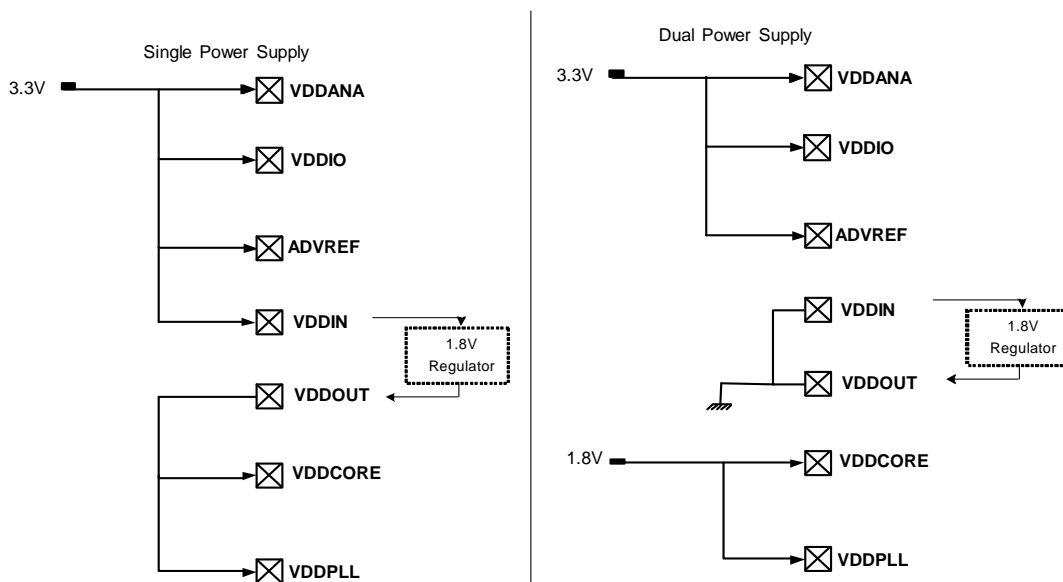

7.2 Voltage Regulator

7.2.1 Single Power Supply

The AT32UC3A embeds a voltage regulator that converts from 3.3V to 1.8V. The regulator takes its input voltage from VDDIN, and supplies the output voltage on VDDOUT. VDDOUT should be externally connected to the 1.8V domains.

Adequate input supply decoupling is mandatory for VDDIN in order to improve startup stability and reduce source voltage drop. Two input decoupling capacitors must be placed close to the chip.

Adequate output supply decoupling is mandatory for VDDOUT to reduce ripple and avoid oscillations. The best way to achieve this is to use two capacitors in parallel between VDDOUT and GND as close to the chip as possible

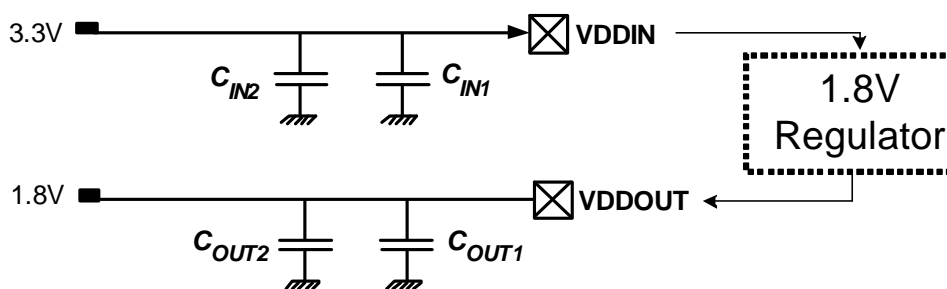

Refer to [Section 12.3 on page 42](#) for decoupling capacitors values and regulator characteristics

7.2.2 Dual Power Supply

In case of dual power supply, VDDIN and VDDOUT should be connected to ground to prevent from leakage current.

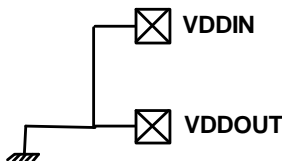

7.3 Analog-to-Digital Converter (A.D.C) reference.

The ADC reference (ADVREF) must be provided from an external source. Two decoupling capacitors must be used to insure proper decoupling.

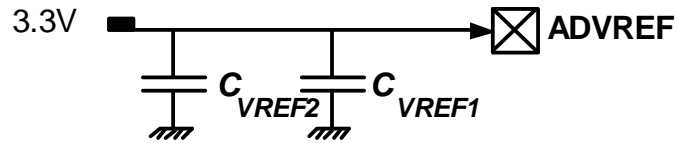

Refer to [Section 12.4 on page 42](#) for decoupling capacitors values and electrical characteristics.

In case ADC is not used, the ADVREF pin should be connected to GND to avoid extra consumption.

8. I/O Line Considerations

8.1 JTAG pins

TMS, TDI and TCK have pull-up resistors. TDO is an output, driven at up to VDDIO, and has no pull-up resistor.

8.2 RESET_N pin

The RESET_N pin is a schmitt input and integrates a permanent pull-up resistor to VDDIO. As the product integrates a power-on reset cell, the RESET_N pin can be left unconnected in case no reset from the system needs to be applied to the product.

8.3 TWI pins

When these pins are used for TWI, the pins are open-drain outputs with slew-rate limitation and inputs with inputs with spike-filtering. When used as GPIO-pins or used for other peripherals, the pins have the same characteristics as PIO pins.

8.4 GPIO pins

All the I/O lines integrate a programmable pull-up resistor. Programming of this pull-up resistor is performed independently for each I/O line through the GPIO Controllers. After reset, I/O lines default as inputs with pull-up resistors disabled, except when indicated otherwise in the column “Reset State” of the GPIO Controller multiplexing tables.

9. Memories

9.1 Embedded Memories

- **Internal High-Speed Flash**
 - 512 KBytes (AT32UC3A0512, AT32UC3A1512)
 - 256 KBytes (AT32UC3A0256, AT32UC3A1256)
 - 128 KBytes (AT32UC3A1128, AT32UC3A2128)
 - 0 Wait State Access at up to 33 MHz in Worst Case Conditions
 - 1 Wait State Access at up to 66 MHz in Worst Case Conditions
 - Pipelined Flash Architecture, allowing burst reads from sequential Flash locations, hiding penalty of 1 wait state access
 - Pipelined Flash Architecture typically reduces the cycle penalty of 1 wait state operation to only 15% compared to 0 wait state operation
 - 100 000 Write Cycles, 15-year Data Retention Capability
 - 4 ms Page Programming Time, 8 ms Chip Erase Time
 - Sector Lock Capabilities, Bootloader Protection, Security Bit
 - 32 Fuses, Erased During Chip Erase
 - User Page For Data To Be Preserved During Chip Erase
- **Internal High-Speed SRAM, Single-cycle access at full speed**
 - 64 KBytes (AT32UC3A0512, AT32UC3A0256, AT32UC3A1512, AT32UC3A1256)
 - 32KBytes (AT32UC3A1128)

9.2 Physical Memory Map

The system bus is implemented as a bus matrix. All system bus addresses are fixed, and they are never remapped in any way, not even in boot. Note that AVR32 UC CPU uses unsegmented translation, as described in the AVR32 Architecture Manual. The 32-bit physical address space is mapped as follows:

Table 9-1. AT32UC3A Physical Memory Map

Device	Start Address	Size					
		AT32UC3A0512	AT32UC3A1512	AT32UC3A0256	AT32UC3A1256	AT32UC3A0128	AT32UC3A1128
Embedded SRAM	0x0000_0000	64 Kbyte	64 Kbyte	64 Kbyte	64 Kbyte	32 Kbyte	32 Kbyte
Embedded Flash	0x8000_0000	512 Kbyte	512 Kbyte	256 Kbyte	256 Kbyte	128 Kbyte	128 Kbyte
EBI SRAM CS0	0xC000_0000	16 Mbyte	-	16 Mbyte	-	16 Mbyte	-
EBI SRAM CS2	0xC800_0000	16 Mbyte	-	16 Mbyte	-	16 Mbyte	-
EBI SRAM CS3	0xCC00_0000	16 Mbyte	-	16 Mbyte	-	16 Mbyte	-
EBI SRAM CS1 /SDRAM CS0	0xD000_0000	128 Mbyte	-	128 Mbyte	-	128 Mbyte	-
USB Configuration	0xE000_0000	64 Kbyte	64 Kbyte	64 Kbyte	64 Kbyte	64 Kbyte	64 Kbyte
HSB-PB Bridge A	0xFFFFE_0000	64 Kbyte	64 Kbyte	64 Kbyte	64 Kbyte	64 Kbyte	64 Kbyte
HSB-PB Bridge B	0xFFFFF_0000	64 Kbyte	64 Kbyte	64 kByte	64 kByte	64 Kbyte	64 Kbyte

Table 9-2. Flash Memory Parameters

Part Number	Flash Size (FLASH_PW)	Number of pages (FLASH_P)	Page size (FLASH_W)	General Purpose Fuse bits (FLASH_F)
AT32UC3A0512	512 Kbytes	1024	128 words	32 fuses
AT32UC3A1512	512 Kbytes	1024	128 words	32 fuses
AT32UC3A0256	256 Kbytes	512	128 words	32 fuses
AT32UC3A1256	256 Kbytes	512	128 words	32 fuses
AT32UC3A1128	128 Kbytes	256	128 words	32 fuses
AT32UC3A0128	128 Kbytes	256	128 words	32 fuses

9.3 Bus Matrix Connections

Accesses to unused areas returns an error result to the master requesting such an access.

The bus matrix has the several masters and slaves. Each master has its own bus and its own decoder, thus allowing a different memory mapping per master. The master number in the table below can be used to index the HMATRIX control registers. For example, MCFG0 is associated with the CPU Data master interface.

Table 9-3. High Speed Bus masters

Master 0	CPU Data
Master 1	CPU Instruction
Master 2	CPU SAB
Master 3	PDCA
Master 4	MACB DMA
Master 5	USBB DMA

Each slave has its own arbiter, thus allowing a different arbitration per slave. The slave number in the table below can be used to index the HMATRIX control registers. For example, SCFG3 is associated with the Internal SRAM Slave Interface.

Table 9-4. High Speed Bus slaves

Slave 0	Internal Flash
Slave 1	HSB-PB Bridge 0
Slave 2	HSB-PB Bridge 1
Slave 3	Internal SRAM
Slave 4	USBB DPRAM
Slave 5	EBI

Figure 9-1. HMatrix Master / Slave Connections

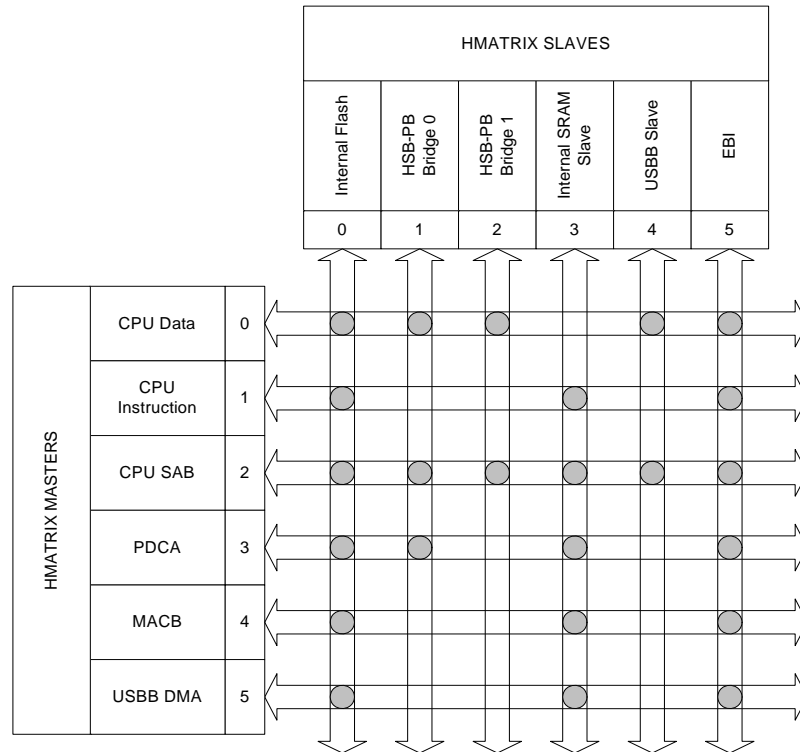

10. Peripherals

10.1 Peripheral address map

Table 10-1. Peripheral Address Mapping

Address	Peripheral Name	Bus
0xE0000000	USBB USBB Slave Interface - USBB	HSB
0xFFFE0000	USBB USBB Configuration Interface - USBB	PBB
0xFFFE1000	HMATRIX HMATRIX Configuration Interface - HMATRIX	PBB
0xFFFE1400	FLASHC Flash Controller - FLASHC	PBB
0xFFFE1800	MACB MACB Configuration Interface - MACB	PBB
0xFFFE1C00	SMC Static Memory Controller Configuration Interface - SMC	PBB
0xFFFE2000	SDRAMC SDRAM Controller Configuration Interface - SDRAMC	PBB
0xFFFF0000	PDCA Peripheral DMA Interface - PDCA	PBA
0xFFFF0800	INTC Interrupt Controller Interface - INTC	PBA
0xFFFF0C00	PM Power Manager - PM	PBA
0xFFFF0D00	RTC Real Time Clock - RTC	PBA
0xFFFF0D30	WDT WatchDog Timer - WDT	PBA
0xFFFF0D80	EIC External Interrupt Controller - EIC	PBA
0xFFFF1000	GPIO General Purpose IO Controller - GPIO	PBA
0xFFFF1400	USART0 Universal Synchronous Asynchronous Receiver Transmitter - USART0	PBA
0xFFFF1800	USART1 Universal Synchronous Asynchronous Receiver Transmitter - USART1	PBA

Table 10-1. Peripheral Address Mapping (Continued)

Address	Peripheral Name	Bus
0xFFFF1C00	USART2 Universal Synchronous Asynchronous Receiver Transmitter - USART2	PBA
0xFFFF2000	USART3 Universal Synchronous Asynchronous Receiver Transmitter - USART3	PBA
0xFFFF2400	SPI0 Serial Peripheral Interface - SPI0	PBA
0xFFFF2800	SPI1 Serial Peripheral Interface - SPI1	PBA
0xFFFF2C00	TWI Two Wire Interface - TWI	PBA
0xFFFF3000	PWM Pulse Width Modulation Controller - PWM	PBA
0xFFFF3400	SSC Synchronous Serial Controller - SSC	PBA
0xFFFF3800	TC Timer/Counter - TC	PBA
0xFFFF3C00	ADC Analog To Digital Converter - ADC	PBA

10.2 CPU Local Bus Mapping

Some of the registers in the GPIO module are mapped onto the CPU local bus, in addition to being mapped on the Peripheral Bus. These registers can therefore be reached both by accesses on the Peripheral Bus, and by accesses on the local bus.

Mapping these registers on the local bus allows cycle-deterministic toggling of GPIO pins since the CPU and GPIO are the only modules connected to this bus. Also, since the local bus runs at CPU speed, one write or read operation can be performed per clock cycle to the local bus-mapped GPIO registers.

The following GPIO registers are mapped on the local bus:

Table 10-2. Local bus mapped GPIO registers

Port	Register	Mode	Local Bus Address	Access
0	Output Driver Enable Register (ODER)	WRITE	0x4000_0040	Write-only
		SET	0x4000_0044	Write-only
		CLEAR	0x4000_0048	Write-only
		TOGGLE	0x4000_004C	Write-only
	Output Value Register (OVR)	WRITE	0x4000_0050	Write-only
		SET	0x4000_0054	Write-only
		CLEAR	0x4000_0058	Write-only
		TOGGLE	0x4000_005C	Write-only
	Pin Value Register (PVR)	-	0x4000_0060	Read-only
	1	Output Driver Enable Register (ODER)	WRITE	0x4000_0140
SET			0x4000_0144	Write-only
CLEAR			0x4000_0148	Write-only
TOGGLE			0x4000_014C	Write-only
Output Value Register (OVR)		WRITE	0x4000_0150	Write-only
		SET	0x4000_0154	Write-only
		CLEAR	0x4000_0158	Write-only
		TOGGLE	0x4000_015C	Write-only
Pin Value Register (PVR)		-	0x4000_0160	Read-only
2		Output Driver Enable Register (ODER)	WRITE	0x4000_0240
	SET		0x4000_0244	Write-only
	CLEAR		0x4000_0248	Write-only
	TOGGLE		0x4000_024C	Write-only
	Output Value Register (OVR)	WRITE	0x4000_0250	Write-only
		SET	0x4000_0254	Write-only
		CLEAR	0x4000_0258	Write-only
		TOGGLE	0x4000_025C	Write-only
	Pin Value Register (PVR)	-	0x4000_0260	Read-only

Table 10-2. Local bus mapped GPIO registers

Port	Register	Mode	Local Bus Address	Access
3	Output Driver Enable Register (ODER)	WRITE	0x4000_0340	Write-only
		SET	0x4000_0344	Write-only
		CLEAR	0x4000_0348	Write-only
		TOGGLE	0x4000_034C	Write-only
	Output Value Register (OVR)	WRITE	0x4000_0350	Write-only
		SET	0x4000_0354	Write-only
		CLEAR	0x4000_0358	Write-only
		TOGGLE	0x4000_035C	Write-only
	Pin Value Register (PVR)	-	0x4000_0360	Read-only

10.3 Interrupt Request Signal Map

The various modules may output Interrupt request signals. These signals are routed to the Interrupt Controller (INTC), described in a later chapter. The Interrupt Controller supports up to 64 groups of interrupt requests. Each group can have up to 32 interrupt request signals. All interrupt signals in the same group share the same autovector address and priority level. Refer to the documentation for the individual submodules for a description of the semantics of the different interrupt requests.

The interrupt request signals are connected to the INTC as follows.

Table 10-3. Interrupt Request Signal Map

Group	Line	Module	Signal
0	0	AVR32 UC CPU with optional MPU and optional OCD	SYSBLOCK COMPARE
1	0	External Interrupt Controller	EIC 0
	1	External Interrupt Controller	EIC 1
	2	External Interrupt Controller	EIC 2
	3	External Interrupt Controller	EIC 3
	4	External Interrupt Controller	EIC 4
	5	External Interrupt Controller	EIC 5
	6	External Interrupt Controller	EIC 6
	7	External Interrupt Controller	EIC 7
	8	Real Time Counter	RTC
	9	Power Manager	PM
	10	Frequency Meter	FREQM

Table 10-3. Interrupt Request Signal Map

2	0	General Purpose Input/Output	GPIO 0
	1	General Purpose Input/Output	GPIO 1
	2	General Purpose Input/Output	GPIO 2
	3	General Purpose Input/Output	GPIO 3
	4	General Purpose Input/Output	GPIO 4
	5	General Purpose Input/Output	GPIO 5
	6	General Purpose Input/Output	GPIO 6
	7	General Purpose Input/Output	GPIO 7
	8	General Purpose Input/Output	GPIO 8
	9	General Purpose Input/Output	GPIO 9
	10	General Purpose Input/Output	GPIO 10
	11	General Purpose Input/Output	GPIO 11
	12	General Purpose Input/Output	GPIO 12
	13	General Purpose Input/Output	GPIO 13
3	0	Peripheral DMA Controller	PDCA 0
	1	Peripheral DMA Controller	PDCA 1
	2	Peripheral DMA Controller	PDCA 2
	3	Peripheral DMA Controller	PDCA 3
	4	Peripheral DMA Controller	PDCA 4
	5	Peripheral DMA Controller	PDCA 5
	6	Peripheral DMA Controller	PDCA 6
	7	Peripheral DMA Controller	PDCA 7
	8	Peripheral DMA Controller	PDCA 8
	9	Peripheral DMA Controller	PDCA 9
	10	Peripheral DMA Controller	PDCA 10
	11	Peripheral DMA Controller	PDCA 11
	12	Peripheral DMA Controller	PDCA 12
	13	Peripheral DMA Controller	PDCA 13
	14	Peripheral DMA Controller	PDCA 14
4	0	Flash Controller	FLASHC
5	0	Universal Synchronous/Asynchronous Receiver/Transmitter	USART0
6	0	Universal Synchronous/Asynchronous Receiver/Transmitter	USART1
7	0	Universal Synchronous/Asynchronous Receiver/Transmitter	USART2
8	0	Universal Synchronous/Asynchronous Receiver/Transmitter	USART3

Table 10-3. Interrupt Request Signal Map

9	0	Serial Peripheral Interface	SPI0
10	0	Serial Peripheral Interface	SPI1
11	0	Two-wire Interface	TWI
12	0	Pulse Width Modulation Controller	PWM
13	0	Synchronous Serial Controller	SSC
14	0	Timer/Counter	TC0
	1	Timer/Counter	TC1
	2	Timer/Counter	TC2
15	0	Analog to Digital Converter	ADC
16	0	Ethernet MAC	MACB
17	0	USB 2.0 OTG Interface	USBB
18	0	SDRAM Controller	SDRAMC
19	0	Audio Bitstream DAC	DAC

10.4 Clock Connections

10.4.1 Timer/Counters

Each Timer/Counter channel can independently select an internal or external clock source for its counter:

Table 10-4. Timer/Counter clock connections

Source	Name	Connection
Internal	TIMER_CLOCK1	32 KHz Oscillator
	TIMER_CLOCK2	PBA clock / 2
	TIMER_CLOCK3	PBA clock / 8
	TIMER_CLOCK4	PBA clock / 32
	TIMER_CLOCK5	PBA clock / 128
External	XC0	See Section 10.7
	XC1	
	XC2	

10.4.2 USARTs

Each USART can be connected to an internally divided clock:

Table 10-5. USART clock connections

USART	Source	Name	Connection
0	Internal	CLK_DIV	PBA clock / 8
1			
2			
3			

10.4.3 SPIs

Each SPI can be connected to an internally divided clock:

Table 10-6. SPI clock connections

SPI	Source	Name	Connection
0	Internal	CLK_DIV	PBA clock or PBA clock / 32
1			

10.5 Nexus OCD AUX port connections

If the OCD trace system is enabled, the trace system will take control over a number of pins, irrespectively of the PIO configuration. Two different OCD trace pin mappings are possible, depending on the configuration of the OCD AXS register. For details, see the AVR32 UC Technical Reference Manual.

Table 10-7. Nexus OCD AUX port connections

Pin	AXS=0	AXS=1
EVTI_N	PB19	PA08
MDO[5]	PB16	PA27
MDO[4]	PB14	PA26
MDO[3]	PB13	PA25
MDO[2]	PB12	PA24
MDO[1]	PB11	PA23
MDO[0]	PB10	PA22
EVTO_N	PB20	PB20
MCKO	PB21	PA21
MSEO[1]	PB04	PA07
MSEO[0]	PB17	PA28

10.6 PDC handshake signals

The PDC and the peripheral modules communicate through a set of handshake signals. The following table defines the valid settings for the Peripheral Identifier (PID) in the PDC Peripheral Select Register (PSR).

Table 10-8. PDC Handshake Signals

PID Value	Peripheral module & direction
0	ADC
1	SSC - RX
2	USART0 - RX
3	USART1 - RX

Table 10-8. PDC Handshake Signals

PID Value	Peripheral module & direction
4	USART2 - RX
5	USART3 - RX
6	TWI - RX
7	SPI0 - RX
8	SPI1 - RX
9	SSC - TX
10	USART0 - TX
11	USART1 - TX
12	USART2 - TX
13	USART3 - TX
14	TWI - TX
15	SPI0 - TX
16	SPI1 - TX
17	ABDAC

10.7 Peripheral Multiplexing on I/O lines

Each GPIO line can be assigned to one of 3 peripheral functions; A, B or C. The following table define how the I/O lines on the peripherals A, B and C are multiplexed by the GPIO.

Table 10-9. GPIO Controller Function Multiplexing

TQFP100	VQFP144	PIN	GPIO Pin	Function A	Function B	Function C
19	25	PA00	GPIO 0	USART0 - RXD	TC - CLK0	
20	27	PA01	GPIO 1	USART0 - TXD	TC - CLK1	
23	30	PA02	GPIO 2	USART0 - CLK	TC - CLK2	
24	32	PA03	GPIO 3	USART0 - RTS	EIM - EXTINT[4]	DAC - DATA[0]
25	34	PA04	GPIO 4	USART0 - CTS	EIM - EXTINT[5]	DAC - DATAN[0]
26	39	PA05	GPIO 5	USART1 - RXD	PWM - PWM[4]	
27	41	PA06	GPIO 6	USART1 - TXD	PWM - PWM[5]	
28	43	PA07	GPIO 7	USART1 - CLK	PM - GCLK[0]	SPI0 - NPCS[3]
29	45	PA08	GPIO 8	USART1 - RTS	SPI0 - NPCS[1]	EIM - EXTINT[7]
30	47	PA09	GPIO 9	USART1 - CTS	SPI0 - NPCS[2]	MACB - WOL
31	48	PA10	GPIO 10	SPI0 - NPCS[0]	EIM - EXTINT[6]	
33	50	PA11	GPIO 11	SPI0 - MISO	USB - USB_ID	
36	53	PA12	GPIO 12	SPI0 - MOSI	USB - USB_VBOF	
37	54	PA13	GPIO 13	SPI0 - SCK		
39	56	PA14	GPIO 14	SSC - TX_FRAME_SYNC	SPI1 - NPCS[0]	EBI - NCS[0]
40	57	PA15	GPIO 15	SSC - TX_CLOCK	SPI1 - SCK	EBI - ADDR[20]

Table 10-9. GPIO Controller Function Multiplexing

41	58	PA16	GPIO 16	SSC - TX_DATA	SPI1 - MOSI	EBI - ADDR[21]
42	60	PA17	GPIO 17	SSC - RX_DATA	SPI1 - MISO	EBI - ADDR[22]
43	62	PA18	GPIO 18	SSC - RX_CLOCK	SPI1 - NPCS[1]	MACB - WOL
44	64	PA19	GPIO 19	SSC - RX_FRAME_SYNC	SPI1 - NPCS[2]	
45	66	PA20	GPIO 20	EIM - EXTINT[8]	SPI1 - NPCS[3]	
51	73	PA21	GPIO 21	ADC - AD[0]	EIM - EXTINT[0]	USB - USB_ID
52	74	PA22	GPIO 22	ADC - AD[1]	EIM - EXTINT[1]	USB - USB_VBOF
53	75	PA23	GPIO 23	ADC - AD[2]	EIM - EXTINT[2]	DAC - DATA[1]
54	76	PA24	GPIO 24	ADC - AD[3]	EIM - EXTINT[3]	DAC - DATAN[1]
55	77	PA25	GPIO 25	ADC - AD[4]	EIM - SCAN[0]	EBI - NCS[0]
56	78	PA26	GPIO 26	ADC - AD[5]	EIM - SCAN[1]	EBI - ADDR[20]
57	79	PA27	GPIO 27	ADC - AD[6]	EIM - SCAN[2]	EBI - ADDR[21]
58	80	PA28	GPIO 28	ADC - AD[7]	EIM - SCAN[3]	EBI - ADDR[22]
83	122	PA29	GPIO 29	TWI - SDA	USART2 - RTS	
84	123	PA30	GPIO 30	TWI - SCL	USART2 - CTS	
65	88	PB00	GPIO 32	MACB - TX_CLK	USART2 - RTS	USART3 - RTS
66	90	PB01	GPIO 33	MACB - TX_EN	USART2 - CTS	USART3 - CTS
70	96	PB02	GPIO 34	MACB - TXD[0]	DAC - DATA[0]	
71	98	PB03	GPIO 35	MACB - TXD[1]	DAC - DATAN[0]	
72	100	PB04	GPIO 36	MACB - CRS	USART3 - CLK	EBI - NCS[3]
73	102	PB05	GPIO 37	MACB - RXD[0]	DAC - DATA[1]	
74	104	PB06	GPIO 38	MACB - RXD[1]	DAC - DATAN[1]	
75	106	PB07	GPIO 39	MACB - RX_ER		
76	111	PB08	GPIO 40	MACB - MDC		
77	113	PB09	GPIO 41	MACB - MDIO		
78	115	PB10	GPIO 42	MACB - TXD[2]	USART3 - RXD	EBI - SDCK
81	119	PB11	GPIO 43	MACB - TXD[3]	USART3 - TXD	EBI - SDCKE
82	121	PB12	GPIO 44	MACB - TX_ER	TC - CLK0	EBI - RAS
87	126	PB13	GPIO 45	MACB - RXD[2]	TC - CLK1	EBI - CAS
88	127	PB14	GPIO 46	MACB - RXD[3]	TC - CLK2	EBI - SDWE
95	134	PB15	GPIO 47	MACB - RX_DV		
96	136	PB16	GPIO 48	MACB - COL	USB - USB_ID	EBI - SDA10
98	139	PB17	GPIO 49	MACB - RX_CLK	USB - USB_VBOF	EBI - ADDR[23]
99	141	PB18	GPIO 50	MACB - SPEED	ADC - TRIGGER	PWM - PWM[6]
100	143	PB19	GPIO 51	PWM - PWM[0]	PM - GCLK[0]	EIM - SCAN[4]
1	3	PB20	GPIO 52	PWM - PWM[1]	PM - GCLK[1]	EIM - SCAN[5]
2	5	PB21	GPIO 53	PWM - PWM[2]	PM - GCLK[2]	EIM - SCAN[6]
3	6	PB22	GPIO 54	PWM - PWM[3]	PM - GCLK[3]	EIM - SCAN[7]
6	9	PB23	GPIO 55	TC - A0	USART1 - DCD	

Table 10-9. GPIO Controller Function Multiplexing

7	11	PB24	GPIO 56	TC - B0	USART1 - DSR	
8	13	PB25	GPIO 57	TC - A1	USART1 - DTR	
9	14	PB26	GPIO 58	TC - B1	USART1 - RI	
10	15	PB27	GPIO 59	TC - A2	PWM - PWM[4]	
14	19	PB28	GPIO 60	TC - B2	PWM - PWM[5]	
15	20	PB29	GPIO 61	USART2 - RXD	PM - GCLK[1]	EBI - NCS[2]
16	21	PB30	GPIO 62	USART2 - TXD	PM - GCLK[2]	EBI - SDCS
17	22	PB31	GPIO 63	USART2 - CLK	PM - GCLK[3]	EBI - NWAIT
63	85	PC00	GPIO 64			
64	86	PC01	GPIO 65			
85	124	PC02	GPIO 66			
86	125	PC03	GPIO 67			
93	132	PC04	GPIO 68			
94	133	PC05	GPIO 69			
	1	PX00	GPIO 100	EBI - DATA[10]	USART0 - RXD	
	2	PX01	GPIO 99	EBI - DATA[9]	USART0 - TXD	
	4	PX02	GPIO 98	EBI - DATA[8]	USART0 - CTS	
	10	PX03	GPIO 97	EBI - DATA[7]	USART0 - RTS	
	12	PX04	GPIO 96	EBI - DATA[6]	USART1 - RXD	
	24	PX05	GPIO 95	EBI - DATA[5]	USART1 - TXD	
	26	PX06	GPIO 94	EBI - DATA[4]	USART1 - CTS	
	31	PX07	GPIO 93	EBI - DATA[3]	USART1 - RTS	
	33	PX08	GPIO 92	EBI - DATA[2]	USART3 - RXD	
	35	PX09	GPIO 91	EBI - DATA[1]	USART3 - TXD	
	38	PX10	GPIO 90	EBI - DATA[0]	USART2 - RXD	
	40	PX11	GPIO 109	EBI - NWE1	USART2 - TXD	
	42	PX12	GPIO 108	EBI - NWE0	USART2 - CTS	
	44	PX13	GPIO 107	EBI - NRD	USART2 - RTS	
	46	PX14	GPIO 106	EBI - NCS[1]		TC - A0
	59	PX15	GPIO 89	EBI - ADDR[19]	USART3 - RTS	TC - B0
	61	PX16	GPIO 88	EBI - ADDR[18]	USART3 - CTS	TC - A1
	63	PX17	GPIO 87	EBI - ADDR[17]		TC - B1
	65	PX18	GPIO 86	EBI - ADDR[16]		TC - A2
	67	PX19	GPIO 85	EBI - ADDR[15]	EIM - SCAN[0]	TC - B2
	87	PX20	GPIO 84	EBI - ADDR[14]	EIM - SCAN[1]	TC - CLK0
	89	PX21	GPIO 83	EBI - ADDR[13]	EIM - SCAN[2]	TC - CLK1
	91	PX22	GPIO 82	EBI - ADDR[12]	EIM - SCAN[3]	TC - CLK2
	95	PX23	GPIO 81	EBI - ADDR[11]	EIM - SCAN[4]	
	97	PX24	GPIO 80	EBI - ADDR[10]	EIM - SCAN[5]	

Table 10-9. GPIO Controller Function Multiplexing

	99	PX25	GPIO 79	EBI - ADDR[9]	EIM - SCAN[6]	
	101	PX26	GPIO 78	EBI - ADDR[8]	EIM - SCAN[7]	
	103	PX27	GPIO 77	EBI - ADDR[7]	SPI0 - MISO	
	105	PX28	GPIO 76	EBI - ADDR[6]	SPI0 - MOSI	
	107	PX29	GPIO 75	EBI - ADDR[5]	SPI0 - SCK	
	110	PX30	GPIO 74	EBI - ADDR[4]	SPI0 - NPCS[0]	
	112	PX31	GPIO 73	EBI - ADDR[3]	SPI0 - NPCS[1]	
	114	PX32	GPIO 72	EBI - ADDR[2]	SPI0 - NPCS[2]	
	118	PX33	GPIO 71	EBI - ADDR[1]	SPI0 - NPCS[3]	
	120	PX34	GPIO 70	EBI - ADDR[0]	SPI1 - MISO	
	135	PX35	GPIO 105	EBI - DATA[15]	SPI1 - MOSI	
	137	PX36	GPIO 104	EBI - DATA[14]	SPI1 - SCK	
	140	PX37	GPIO 103	EBI - DATA[13]	SPI1 - NPCS[0]	
	142	PX38	GPIO 102	EBI - DATA[12]	SPI1 - NPCS[1]	
	144	PX39	GPIO 101	EBI - DATA[11]	SPI1 - NPCS[2]	

10.8 Oscillator Pinout

The oscillators are not mapped to the normal A,B or C functions and their muxings are controlled by registers in the Power Manager (PM). Please refer to the power manager chapter for more information about this.

Table 10-10. Oscillator pinout

TQFP100 pin	VQFP144 pin	Pad	Oscillator pin
85	124	PC02	xin0
93	132	PC04	xin1
63	85	PC00	xin32
86	125	PC03	xout0
94	133	PC05	xout1
64	86	PC01	xout32

10.9 USART Configuration

Table 10-11. USART Supported Mode

	SPI	RS485	ISO7816	IrDA	Modem	Manchester Encoding
USART0	Yes	No	No	No	No	No
USART1	Yes	Yes	Yes	Yes	Yes	Yes
USART2	Yes	No	No	No	No	No
USART3	Yes	No	No	No	No	No



10.10 GPIO

The GPIO open drain feature (GPIO ODMER register (Open Drain Mode Enable Register)) is not available for this device.

10.11 Peripheral overview

10.11.1 External Bus Interface

- **Optimized for Application Memory Space support**
- **Integrates Two External Memory Controllers:**
 - Static Memory Controller
 - SDRAM Controller
- **Optimized External Bus:**
 - 16-bit Data Bus
 - 24-bit Address Bus, Up to 16-Mbytes Addressable
 - Optimized pin multiplexing to reduce latencies on External Memories
- **4 SRAM Chip Selects, 1SDRAM Chip Select:**
 - Static Memory Controller on NCS0
 - SDRAM Controller or Static Memory Controller on NCS1
 - Static Memory Controller on NCS2
 - Static Memory Controller on NCS3

10.11.2 Static Memory Controller

- 4 Chip Selects Available
- 64-Mbyte Address Space per Chip Select
- 8-, 16-bit Data Bus
- Word, Halfword, Byte Transfers
- Byte Write or Byte Select Lines
- Programmable Setup, Pulse And Hold Time for Read Signals per Chip Select
- Programmable Setup, Pulse And Hold Time for Write Signals per Chip Select
- Programmable Data Float Time per Chip Select
- Compliant with LCD Module
- External Wait Request
- Automatic Switch to Slow Clock Mode
- Asynchronous Read in Page Mode Supported: Page Size Ranges from 4 to 32 Bytes

10.11.3 SDRAM Controller

- **Numerous Configurations Supported**
 - 2K, 4K, 8K Row Address Memory Parts
 - SDRAM with Two or Four Internal Banks
 - SDRAM with 16-bit Data Path
- **Programming Facilities**
 - Word, Half-word, Byte Access
 - Automatic Page Break When Memory Boundary Has Been Reached
 - Multibank Ping-pong Access
 - Timing Parameters Specified by Software
 - Automatic Refresh Operation, Refresh Rate is Programmable
- **Energy-saving Capabilities**
 - Self-refresh, Power-down and Deep Power Modes Supported

- Supports Mobile SDRAM Devices
- Error Detection
 - Refresh Error Interrupt
- SDRAM Power-up Initialization by Software
- CAS Latency of 1, 2, 3 Supported
- Auto Precharge Command Not Used

10.11.4 USB Controller

- USB 2.0 Compliant, Full-/Low-Speed (FS/LS) and On-The-Go (OTG), 12 Mbit/s
- 7 Pipes/Endpoints
- 960 bytes of Embedded Dual-Port RAM (DPRAM) for Pipes/Endpoints
- Up to 2 Memory Banks per Pipe/Endpoint (Not for Control Pipe/Endpoint)
- Flexible Pipe/Endpoint Configuration and Management with Dedicated DMA Channels
- On-Chip Transceivers Including Pull-Ups

10.11.5 Serial Peripheral Interface

- Supports communication with serial external devices
 - Four chip selects with external decoder support allow communication with up to 15 peripherals
 - Serial memories, such as DataFlash and 3-wire EEPROMs
 - Serial peripherals, such as ADCs, DACs, LCD Controllers, CAN Controllers and Sensors
 - External co-processors
- Master or slave serial peripheral bus interface
 - 8- to 16-bit programmable data length per chip select
 - Programmable phase and polarity per chip select
 - Programmable transfer delays between consecutive transfers and between clock and data per chip select
 - Programmable delay between consecutive transfers
 - Selectable mode fault detection
- Very fast transfers supported
 - Transfers with baud rates up to Peripheral Bus A (PBA) max frequency
 - The chip select line may be left active to speed up transfers on the same device

10.11.6 Two-wire Interface

- High speed up to 400kbit/s
- Compatibility with standard two-wire serial memory
- One, two or three bytes for slave address
- Sequential read/write operations

10.11.7 USART

- Programmable Baud Rate Generator
- 5- to 9-bit full-duplex synchronous or asynchronous serial communications
 - 1, 1.5 or 2 stop bits in Asynchronous Mode or 1 or 2 stop bits in Synchronous Mode
 - Parity generation and error detection
 - Framing error detection, overrun error detection
 - MSB- or LSB-first
 - Optional break generation and detection
 - By 8 or by-16 over-sampling receiver frequency
 - Hardware handshaking RTS-CTS
 - Receiver time-out and transmitter timeguard
 - Optional Multi-drop Mode with address generation and detection

- Optional Manchester Encoding
- RS485 with driver control signal
- ISO7816, T = 0 or T = 1 Protocols for interfacing with smart cards
 - NACK handling, error counter with repetition and iteration limit
- IrDA modulation and demodulation
 - Communication at up to 115.2 Kbps
- Test Modes
 - Remote Loopback, Local Loopback, Automatic Echo
- SPI Mode
 - Master or Slave
 - Serial Clock Programmable Phase and Polarity
 - SPI Serial Clock (SCK) Frequency up to Internal Clock Frequency PBA/4
- Supports Connection of Two Peripheral DMA Controller Channels (PDC)
 - Offers Buffer Transfer without Processor Intervention

10.11.8 Serial Synchronous Controller

- Provides serial synchronous communication links used in audio and telecom applications (with CODECs in Master or Slave Modes, I2S, TDM Buses, Magnetic Card Reader, etc.)
- Contains an independent receiver and transmitter and a common clock divider
- Offers a configurable frame sync and data length
- Receiver and transmitter can be programmed to start automatically or on detection of different event on the frame sync signal
- Receiver and transmitter include a data signal, a clock signal and a frame synchronization signal

10.11.9 Timer Counter

- Three 16-bit Timer Counter Channels
- Wide range of functions including:
 - Frequency Measurement
 - Event Counting
 - Interval Measurement
 - Pulse Generation
 - Delay Timing
 - Pulse Width Modulation
 - Up/down Capabilities
- Each channel is user-configurable and contains:
 - Three external clock inputs
 - Five internal clock inputs
 - Two multi-purpose input/output signals
- Two global registers that act on all three TC Channels

10.11.10 Pulse Width Modulation Controller

- 7 channels, one 20-bit counter per channel
- Common clock generator, providing Thirteen Different Clocks
 - A Modulo n counter providing eleven clocks
 - Two independent Linear Dividers working on modulo n counter outputs
- Independent channel programming
 - Independent Enable Disable Commands
 - Independent Clock
 - Independent Period and Duty Cycle, with Double Bufferization
 - Programmable selection of the output waveform polarity
 - Programmable center or left aligned output waveform

10.11.11 Ethernet 10/100 MAC

- Compatibility with IEEE Standard 802.3
- 10 and 100 Mbits per second data throughput capability
- Full- and half-duplex operations
- MII or RMI interface to the physical layer
- Register Interface to address, data, status and control registers
- DMA Interface, operating as a master on the Memory Controller
- Interrupt generation to signal receive and transmit completion
- 28-byte transmit and 28-byte receive FIFOs
- Automatic pad and CRC generation on transmitted frames
- Address checking logic to recognize four 48-bit addresses
- Support promiscuous mode where all valid frames are copied to memory
- Support physical layer management through MDIO interface control of alarm and update time/calendar data

10.11.12 Audio Bitstream DAC

- Digital Stereo DAC
- Oversampled D/A conversion architecture
 - Oversampling ratio fixed 128x
 - FIR equalization filter
 - Digital interpolation filter: Comb4
 - 3rd Order Sigma-Delta D/A converters
- Digital bitstream outputs
- Parallel interface
- Connected to Peripheral DMA Controller for background transfer without CPU intervention

11. Boot Sequence

This chapter summarizes the boot sequence of the AT32UC3A. The behaviour after power-up is controlled by the Power Manager. For specific details, refer to [Section 13. "Power Manager \(PM\)" on page 53](#).

11.1 Starting of clocks

After power-up, the device will be held in a reset state by the Power-On Reset circuitry, until the power has stabilized throughout the device. Once the power has stabilized, the device will use the internal RC Oscillator as clock source.

On system start-up, the PLLs are disabled. All clocks to all modules are running. No clocks have a divided frequency, all parts of the system receives a clock with the same frequency as the internal RC Oscillator.

11.2 Fetching of initial instructions

After reset has been released, the AVR32 UC CPU starts fetching instructions from the reset address, which is 0x8000_0000. This address points to the first address in the internal Flash.

The code read from the internal Flash is free to configure the system to use for example the PLLs, to divide the frequency of the clock routed to some of the peripherals, and to gate the clocks to unused peripherals.

12. Electrical Characteristics

12.1 Absolute Maximum Ratings*

Operating Temperature	-40°C to +85°C
Storage Temperature	-60°C to +150°C
Voltage on Input Pin with respect to Ground except for PC00, PC01, PC02, PC03, PC04, PC05.....	-0.3V to 5.5V
Voltage on Input Pin with respect to Ground for PC00, PC01, PC02, PC03, PC04, PC05.....	-0.3V to 3.6V
Maximum Operating Voltage (VDDCORE, VDDPLL)	1.95V
Maximum Operating Voltage (VDDIO, VDDIN, VDDANA).....	3.6V
Total DC Output Current on all I/O Pin for TQFP100 package	370 mA
for LQGP144 package	470 mA

*NOTICE: Stresses beyond those listed under “Absolute Maximum Ratings” may cause permanent damage to the device. This is a stress rating only and functional operation of the device at these or other conditions beyond those indicated in the operational sections of this specification is not implied. Exposure to absolute maximum rating conditions for extended periods may affect device reliability.

12.2 DC Characteristics

The following characteristics are applicable to the operating temperature range: $T_A = -40^{\circ}\text{C}$ to 85°C , unless otherwise specified and are certified for a junction temperature up to $T_J = 100^{\circ}\text{C}$.

Table 12-1. DC Characteristics

Symbol	Parameter	Condition	Min.	Typ.	Max	Units
$V_{VDDCORE}$	DC Supply Core		1.65		1.95	V
V_{VDDPLL}	DC Supply PLL		1.65		1.95	V
V_{VDDIO}	DC Supply Peripheral I/Os		3.0		3.6	V
V_{REF}	Analog reference voltage		2.6		3.6	V
V_{IL}	Input Low-level Voltage		-0.3		+0.8	V
V_{IH}	Input High-level Voltage	All GPIOs except for PC00, PC01, PC02, PC03, PC04, PC05.	2.0		5.5V	V
		PC00, PC01, PC02, PC03, PC04, PC05.	2.0		3.6V	V
V_{OL}	Output Low-level Voltage	$I_{OL} = -4\text{mA}$ for PA0-PA20, PB0, PB4-PB9, PB11-PB18, PB24-PB26, PB29-PB31, PX0-PX39			0.4	V
		$I_{OL} = -8\text{mA}$ for PA21-PA30, PB1-PB3, PB10, PB19-PB23, PB27-PB28, PC0-PC5			0.4	V
V_{OH}	Output High-level Voltage	$I_{OH} = 4\text{mA}$ for PA0-PA20, PB0, PB4-PB9, PB11-PB18, PB24-PB26, PB29-PB31, PX0-PX39	$V_{VDDIO} - 0.4$			V
		$I_{OH} = 8\text{mA}$ for PA21-PA30, PB1-PB3, PB10, PB19-PB23, PB27-PB28, PC0-PC5	$V_{VDDIO} - 0.4$			V
I_{OL}	Output Low-level Current	PA0-PA20, PB0, PB4-PB9, PB11-PB18, PB24-PB26, PB29-PB31, PX0-PX39			-4	mA
		PA21-PA30, PB1-PB3, PB10, PB19-PB23, PB27-PB28, PC0-PC5			-8	mA
I_{OH}	Output High-level Current	PA0-PA20, PB0, PB4-PB9, PB11-PB18, PB24-PB26, PB29-PB31, PX0-PX39			4	mA
		PA21-PA30, PB1-PB3, PB10, PB19-PB23, PB27-PB28, PC0-PC5			8	mA
I_{LEAK}	Input Leakage Current	Pullup resistors disabled			1	μA
C_{IN} Input Capacitance		TQFP100 Package		7		pF
		LQFP144 Package		7		pF
R_{PULLUP}	Pull-up Resistance	All GPIO and RESET_N pin.	10K	15K		Ohm

12.3 Regulator characteristics

Table 12-2. Electrical characteristics

Symbol	Parameter	Condition	Min.	Typ.	Max.	Units
V _{VDDIN}	Supply voltage (input)		3	3.3	3.6	V
V _{VDDOUT}	Supply voltage (output)		1.81	1.85	1.89	V
I _{OUT}	Maximum DC output current with V _{VDDIN} = 3.3V				100	mA
	Maximum DC output current with V _{VDDIN} = 2.7V				90	mA
I _{SCR}	Static Current of internal regulator	Low Power mode (stop, deep stop or static) at T _A = 25°C		10		μA

Table 12-3. Decoupling requirements

Symbol	Parameter	Condition	Typ.	Techno.	Units
C _{IN1}	Input Regulator Capacitor 1		1	NPO	nF
C _{IN2}	Input Regulator Capacitor 2		4.7	X7R	μF
C _{OUT1}	Output Regulator Capacitor 1		470	NPO	pF
C _{OUT2}	Output Regulator Capacitor 2		2.2	X7R	μF

12.4 Analog characteristics

Table 12-4. Electrical characteristics

Symbol	Parameter	Condition	Min.	Typ.	Max.	Units
V _{ADVREF}	Analog voltage reference (input)		2.6		3.6	V

Table 12-5. Decoupling requirements

Symbol	Parameter	Condition	Typ.	Techno.	Units
C _{VREF1}	Voltage reference Capacitor 1		10	-	nF
C _{VREF2}	Voltage reference Capacitor 2		1	-	μF

12.4.1 BOD

Table 12-6. BODLEVEL Values

BODLEVEL Value	Typ.	Typ.	Typ.	Units.
00 0000b	1.40	1.47	1.55	V
01 0111b	1.45	1.52	1.6	V
01 1111b	1.55	1.6	1.65	V
10 0111b	1.65	1.69	1.75	V

The values in [Table 12-6](#) describes the values of the BODLEVEL in the flash FGPF_R register.

Table 12-7. BOD Timing

Symbol	Parameter	Test Conditions	Typ.	Max.	Units.
T_{BOD}	Minimum time with $V_{DDCORE} < V_{BOD}$ to detect power failure	Falling V_{DDCORE} from 1.8V to 1.1V	300	800	ns

12.4.2 POR

Table 12-8. Electrical Characteristic

Symbol	Parameter	Test Conditions	Min.	Typ.	Max.	Units.
V_{DDRR}	V_{DDCORE} rise rate to ensure power-on-reset		0.01			V/ms
V_{SSFR}	V_{DDCORE} fall rate to ensure power-on-reset		0.01		400	V/ms
V_{POR+}	Rising threshold voltage: voltage up to which device is kept under reset by POR on rising V_{DDCORE}	Rising V_{DDCORE} : $V_{RESTART} \rightarrow V_{POR+}$	1.35	1.5	1.6	V
V_{POR-}	Falling threshold voltage: voltage when POR resets device on falling V_{DDCORE}	Falling V_{DDCORE} : 1.8V $\rightarrow V_{POR+}$	1.25	1.3	1.4	V
$V_{RESTART}$	On falling V_{DDCORE} , voltage must go down to this value before supply can rise again to ensure reset signal is released at V_{POR+}	Falling V_{DDCORE} : 1.8V $\rightarrow V_{RESTART}$	-0.1		0.5	V
T_{POR}	Minimum time with $V_{DDCORE} < V_{POR-}$	Falling V_{DDCORE} : 1.8V \rightarrow 1.1V		15		us
T_{RST}	Time for reset signal to be propagated to system			200	400	us

12.5 Power Consumption

The values in [Table 12-9](#) and [Table 12-10](#) on page 46 are measured values of power consumption with operating conditions as follows:

- $V_{DDIO} = 3.3V$
- $V_{DDCORE} = V_{DDPLL} = 1.8V$
- $T_A = 25^{\circ}C, T_A = 85^{\circ}C$
- I/Os are configured in input, pull-up enabled.

Figure 12-1. Measurement setup

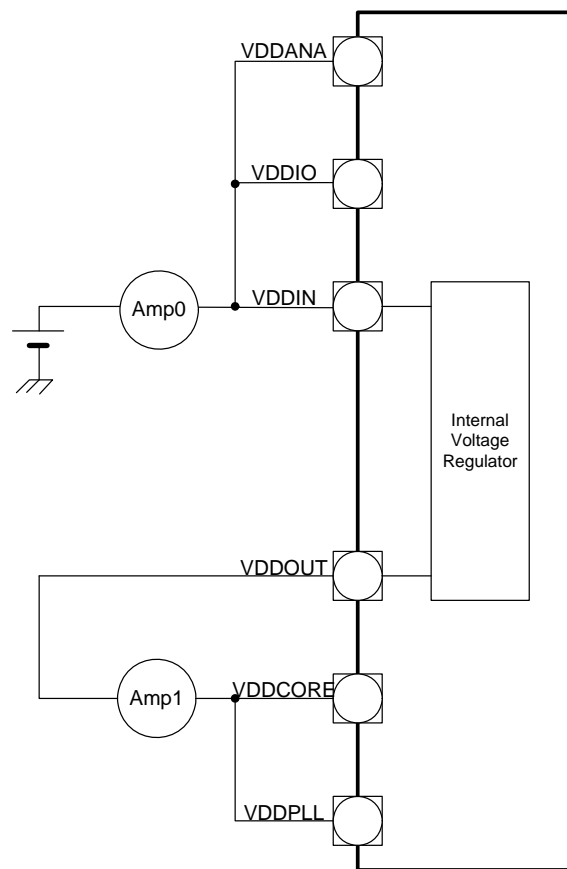

These figures represent the power consumption measured on the power supplies.

Table 12-9. Power Consumption for Different Modes

Mode	Conditions		Typ.	Unit
Active	Typ : Ta =25 °C CPU running from flash ⁽¹⁾ . VDDIN=3.3 V. VDDCORE =1.8V. CPU clocked from PLL0 at f MHz Voltage regulator is on. XIN0 : external clock. ⁽¹⁾ XIN1 stopped. XIN32 stopped PLL0 running All peripheral clocks activated. GPIOs on internal pull-up. JTAG unconnected with ext pull-up.	f = 12 MHz	9	mA
		f = 24 MHz	15	mA
		f = 36MHz	20	mA
		f = 50 MHz	28	mA
		f = 66 MHz	36.3	mA
Idle	Typ : Ta = 25 °C CPU running from flash ⁽¹⁾ . VDDIN=3.3 V. VDDCORE =1.8V. CPU clocked from PLL0 at f MHz Voltage regulator is on. XIN0 : external clock. XIN1 stopped. XIN32 stopped PLL0 running All peripheral clocks activated. GPIOs on internal pull-up. JTAG unconnected with ext pull-up.	f = 12 MHz	5	mA
		f = 24 MHz	10	mA
		f = 36MHz	14	mA
		f = 50 MHz	19	mA
		f = 66 MHz	25.5	mA
Frozen	Typ : Ta = 25 °C CPU running from flash ⁽¹⁾ . CPU clocked from PLL0 at f MHz Voltage regulator is on. XIN0 : external clock. XIN1 stopped. XIN32 stopped PLL0 running All peripheral clocks activated. GPIOs on internal pull-up. JTAG unconnected with ext pull-up.	f = 12 MHz	3	mA
		f = 24 MHz	6	mA
		f = 36MHz	9	mA
		f = 50 MHz	13	mA
		f = 66 MHz	16.8	mA
Standby	Typ : Ta = 25 °C CPU running from flash ⁽¹⁾ . CPU clocked from PLL0 at f MHz Voltage regulator is on. XIN0 : external clock. XIN1 stopped. XIN32 stopped PLL0 running All peripheral clocks activated. GPIOs on internal pull-up. JTAG unconnected with ext pull-up.	f = 12 MHz	1	mA
		f = 24 MHz	2	mA
		f = 36MHz	3	mA
		f = 50 MHz	4	mA
		f = 66 MHz	4.8	mA

Table 12-9. Power Consumption for Different Modes

Mode	Conditions		Typ.	Unit
Stop	Typ : Ta = 25 °C. CPU is in stop mode GPIOs on internal pull-up. All peripheral clocks de-activated. DM and DP pins connected to ground. XIN0,Xin1 and XIN2 are stopped	on Amp0	47	uA
		on Amp1	40	uA
Deepstop	Typ : Ta = 25 °C.CPU is in deepstop mode GPIOs on internal pull-up. All peripheral clocks de-activated. DM and DP pins connected to ground. XIN0,Xin1 and XIN2 are stopped	on Amp0	36	uA
		on Amp1	28	uA
Static	Typ : Ta = 25 °C. CPU is in static mode GPIOs on internal pull-up. All peripheral clocks de-activated. DM and DP pins connected to ground. XIN0,Xin1 and XIN2 are stopped	on Amp0	25	uA
		on Amp1	14	uA

1. Core frequency is generated from XIN0 using the PLL so that 140 MHz < fpll0 < 160 MHz and 10 MHz < fxin0 < 12MHz

Table 12-10. Power Consumption by Peripheral in Active Mode

Peripheral	Typ.	Unit
GPIO	37	μA/MHz
SMC	10	
SDRAMC	4	
ADC	18	
EBI	31	
INTC	25	
TWI	14	
MACB	45	
PDCA	30	
PWM	36	
RTC	7	
SPI	13	
SSC	13	
TC	10	
USART	35	
USB	45	

12.6 Clock Characteristics

These parameters are given in the following conditions:



- $V_{DDCORE} = 1.8V$
- Ambient Temperature = 25°C

12.6.1 CPU/HSB Clock Characteristics

Table 12-11. Core Clock Waveform Parameters

Symbol	Parameter	Conditions	Min	Max	Units
$1/(t_{CPCPU})$	CPU Clock Frequency			66	MHz
t_{CPCPU}	CPU Clock Period		15,15		ns

12.6.2 PBA Clock Characteristics

Table 12-12. PBA Clock Waveform Parameters

Symbol	Parameter	Conditions	Min	Max	Units
$1/(t_{CPPBA})$	PBA Clock Frequency			66	MHz
t_{CPPBA}	PBA Clock Period		15,15		ns

12.6.3 PBB Clock Characteristics

Table 12-13. PBB Clock Waveform Parameters

Symbol	Parameter	Conditions	Min	Max	Units
$1/(t_{CPPBB})$	PBB Clock Frequency			66	MHz
t_{CPPBB}	PBB Clock Period		15,15		ns

12.7 Crystal Oscillator Characteristics

The following characteristics are applicable to the operating temperature range: $T_A = -40^{\circ}C$ to $85^{\circ}C$ and worst case of power supply, unless otherwise specified.

12.7.1 32 KHz Oscillator Characteristics

Table 12-14. 32 KHz Oscillator Characteristics

Symbol	Parameter	Conditions	Min	Typ	Max	Unit
$1/(t_{CP32KHz})$	Crystal Oscillator Frequency				32 768	Hz
C_L	Equivalent Load Capacitance		6		12.5	pF
t_{ST}	Startup Time	$C_L = 6pF^{(1)}$ $C_L = 12.5pF^{(1)}$			600 1200	ms
I_{OSC}	Current Consumption	Active mode			1.8	μA
		Standby mode			0.1	μA

Note: 1. C_L is the equivalent load capacitance.

12.7.2 Main Oscillators Characteristics

Table 12-15. Main Oscillator Characteristics

Symbol	Parameter	Conditions	Min	Typ	Max	Unit
$1/(t_{CPMAIN})$	Crystal Oscillator Frequency		0.45		16	MHz
C_{L1}, C_{L2}	Internal Load Capacitance ($C_{L1} = C_{L2}$)			12		pF
	Duty Cycle		40	50	60	%
t_{ST}	Startup Time				TBD	ms
$1/(t_{CPXIN})$	XIN Clock Frequency	External clock			50	MHz
		Crystal	0.45		16	MHz
t_{CHXIN}	XIN Clock High Half-period		$0.4 \times t_{CPXIN}$		$0.6 \times t_{CPXIN}$	
t_{CLXIN}	XIN Clock Low Half-period		$0.4 \times t_{CPXIN}$		$0.6 \times t_{CPXIN}$	
C_{IN}	XIN Input Capacitance			7		pF

12.7.3 PLL Characteristics

Table 12-16. Phase Lock Loop Characteristics

Symbol	Parameter	Conditions	Min	Typ	Max	Unit
F_{OUT}	Output Frequency		80		240	MHz
F_{IN}	Input Frequency		4		16	MHz
I_{PLL}	Current Consumption	active mode ($F_{out}=80\text{Mhz}$)		250		μA
		active mode ($F_{out}=240\text{Mhz}$)		600		μA

12.8 ADC Characteristics

Table 12-17. Channel Conversion Time and ADC Clock

Parameter	Conditions	Min	Typ	Max	Units
ADC Clock Frequency	10-bit resolution mode			5	MHz
ADC Clock Frequency	8-bit resolution mode			8	MHz
Startup Time	Return from Idle Mode			20	μs
Track and Hold Acquisition Time		600			ns
Conversion Time	ADC Clock = 5 MHz			2	μs
Conversion Time	ADC Clock = 8 MHz			1.25	μs
Throughput Rate	ADC Clock = 5 MHz			384 ⁽¹⁾	kSPS
Throughput Rate	ADC Clock = 8 MHz			533 ⁽²⁾	kSPS

- Notes:
1. Corresponds to 13 clock cycles at 5 MHz: 3 clock cycles for track and hold acquisition time and 10 clock cycles for conversion.
 2. Corresponds to 15 clock cycles at 8 MHz: 5 clock cycles for track and hold acquisition time and 10 clock cycles for conversion.

Table 12-18. External Voltage Reference Input

Parameter	Conditions	Min	Typ	Max	Units
ADVREF Input Voltage Range		2.6		VDDANA	V
ADVREF Average Current	On 13 samples with ADC Clock = 5 MHz		200	250	μA
Current Consumption on VDDANA				1.25	mA

Note: ADVREF should be connected to GND to avoid extra consumption in case ADC is not used.

Table 12-19. Analog Inputs

Parameter	Min	Typ	Max	Units
Input Voltage Range	0		V _{ADVREF}	
Input Leakage Current			1	μA
Input Capacitance		17		pF

Table 12-20. Transfer Characteristics in 8-bit mode

Parameter	Conditions	Min	Typ	Max	Units
Resolution			8		Bit
Absolute Accuracy	f=5MHz			0.8	LSB
	f=8MHz			1.5	LSB
Integral Non-linearity	f=5MHz		0.35	0.5	LSB
	f=8MHz		0.5	1.0	LSB
Differential Non-linearity	f=5MHz		0.3	0.5	LSB
	f=8MHz		0.5	1.0	LSB
Offset Error	f=5MHz	-0.5		0.5	LSB
Gain Error	f=5MHz	-0.5		0.5	LSB

Table 12-21. Transfer Characteristics in 10-bit mode

Parameter	Conditions	Min	Typ	Max	Units
Resolution			10		Bit
Absolute Accuracy	f=5MHz			3	LSB
Integral Non-linearity	f=5MHz		1.5	2	LSB
Differential Non-linearity	f=5MHz		1	2	LSB
	f=2.5MHz		0.6	1	LSB
Offset Error	f=5MHz	-2		2	LSB
Gain Error	f=5MHz	-2		2	LSB

12.9 EBI Timings

These timings are given for worst case process, T = 85-C, VDDCORE = 1.65V, VDDIO = 3V and 40 pF load capacitance.

Table 12-22. SMC Clock Signal.

Symbol	Parameter	Max ⁽¹⁾	Units
1/(t _{CPSMC})	SMC Controller Clock Frequency	1/(t _{cpu})	MHz

Note: 1. The maximum frequency of the SMC interface is the same as the max frequency for the HSB.

Table 12-23. SMC Read Signals with Hold Settings

Symbol	Parameter	Min	Units
NRD Controlled (READ_MODE = 1)			
SMC ₁	Data Setup before NRD High	12	ns
SMC ₂	Data Hold after NRD High	0	
SMC ₃	NRD High to NBS0/A0 Change ⁽¹⁾	nrd hold length * t _{CPSMC} - 1.3	
SMC ₄	NRD High to NBS1 Change ⁽¹⁾	nrd hold length * t _{CPSMC} - 1.3	
SMC ₅	NRD High to NBS2/A1 Change ⁽¹⁾	nrd hold length * t _{CPSMC} - 1.3	
SMC ₆	NRD High to NBS3 Change ⁽¹⁾	nrd hold length * t _{CPSMC} - 1.3	
SMC ₇	NRD High to A2 - A25 Change ⁽¹⁾	nrd hold length * t _{CPSMC} - 1.3	
SMC ₈	NRD High to NCS Inactive ⁽¹⁾	(nrd hold length - ncs rd hold length) * t _{CPSMC} - 2.3	
SMC ₉	NRD Pulse Width	nrd pulse length * t _{CPSMC} - 1.4	
NRD Controlled (READ_MODE = 0)			
SMC ₁₀	Data Setup before NCS High	11.5	ns
SMC ₁₁	Data Hold after NCS High	0	
SMC ₁₂	NCS High to NBS0/A0 Change ⁽¹⁾	ncs rd hold length * t _{CPSMC} - 2.3	
SMC ₁₃	NCS High to NBS0/A0 Change ⁽¹⁾	ncs rd hold length * t _{CPSMC} - 2.3	
SMC ₁₄	NCS High to NBS2/A1 Change ⁽¹⁾	ncs rd hold length * t _{CPSMC} - 2.3	
SMC ₁₅	NCS High to NBS3 Change ⁽¹⁾	ncs rd hold length * t _{CPSMC} - 2.3	
SMC ₁₆	NCS High to A2 - A25 Change ⁽¹⁾	ncs rd hold length * t _{CPSMC} - 4	
SMC ₁₇	NCS High to NRD Inactive ⁽¹⁾	ncs rd hold length - nrd hold length) * t _{CPSMC} - 1.3	
SMC ₁₈	NCS Pulse Width	ncs rd pulse length * t _{CPSMC} - 3.6	

Note: 1. hold length = total cycle duration - setup duration - pulse duration. "hold length" is for "ncs rd hold length" or "nrd hold length".

Table 12-24. SMC Read Signals with no Hold Settings

Symbol	Parameter	Min	Units
NRD Controlled (READ_MODE = 1)			
SMC ₁₉	Data Setup before NRD High	13.7	ns
SMC ₂₀	Data Hold after NRD High	1	
NRD Controlled (READ_MODE = 0)			
SMC ₂₁	Data Setup before NCS High	13.3	ns
SMC ₂₂	Data Hold after NCS High	0	

Table 12-25. SMC Write Signals with Hold Settings

Symbol	Parameter	Min	Units
NRD Controlled (READ_MODE = 1)			
SMC ₂₃	Data Out Valid before NWE High	$(nwe \text{ pulse length} - 1) * t_{CPSMC} - 0.9$	ns
SMC ₂₄	Data Out Valid after NWE High ⁽¹⁾	$nwe \text{ hold length} * t_{CPSMC} - 6$	
SMC ₂₅	NWE High to NBS0/A0 Change ⁽¹⁾	$nwe \text{ hold length} * t_{CPSMC} - 1.9$	
SMC ₂₆	NWE High to NBS1 Change ⁽¹⁾	$nwe \text{ hold length} * t_{CPSMC} - 1.9$	
SMC ₂₉	NWE High to NBS2/A1 Change ⁽¹⁾	$nwe \text{ hold length} * t_{CPSMC} - 1.9$	
SMC ₃₀	NWE High to NBS3 Change ⁽¹⁾	$nwe \text{ hold length} * t_{CPSMC} - 1.9$	
SMC ₃₁	NWE High to A2 - A25 Change ⁽¹⁾	$nwe \text{ hold length} * t_{CPSMC} - 1.7$	
SMC ₃₂	NWE High to NCS Inactive ⁽¹⁾	$(nwe \text{ hold length} - ncs \text{ wr hold length}) * t_{CPSMC} - 2.9$	
SMC ₃₃	NWE Pulse Width	$nwe \text{ pulse length} * t_{CPSMC} - 0.9$	
NRD Controlled (READ_MODE = 0)			
SMC ₃₄	Data Out Valid before NCS High	$(ncs \text{ wr pulse length} - 1) * t_{CPSMC} - 4.6$	ns
SMC ₃₅	Data Out Valid after NCS High ⁽¹⁾	$ncs \text{ wr hold length} * t_{CPSMC} - 5.8$	
SMC ₃₆	NCS High to NWE Inactive ⁽¹⁾	$(ncs \text{ wr hold length} - nwe \text{ hold length}) * t_{CPSMC} - 0.6$	

Note: 1. hold length = total cycle duration - setup duration - pulse duration. "hold length" is for "ncs wr hold length" or "nwe hold length"

Table 12-26. SMC Write Signals with No Hold Settings (NWE Controlled only).

Symbol	Parameter	Min	Units
SMC ₃₇	NWE Rising to A2-A25 Valid	5.4	ns
SMC ₃₈	NWE Rising to NBS0/A0 Valid	5	
SMC ₃₉	NWE Rising to NBS1 Change	5	
SMC ₄₀	NWE Rising to A1/NBS2 Change	5	
SMC ₄₁	NWE Rising to NBS3 Change	5	
SMC ₄₂	NWE Rising to NCS Rising	5.1	
SMC ₄₃	Data Out Valid before NWE Rising	$(nwe\ pulse\ length - 1) * t_{CPSMC} - 1.2$	
SMC ₄₄	Data Out Valid after NWE Rising	5	
SMC ₄₅	NWE Pulse Width	$nwe\ pulse\ length * t_{CPSMC} - 0.9$	

Figure 12-2. SMC Signals for NCS Controlled Accesses.

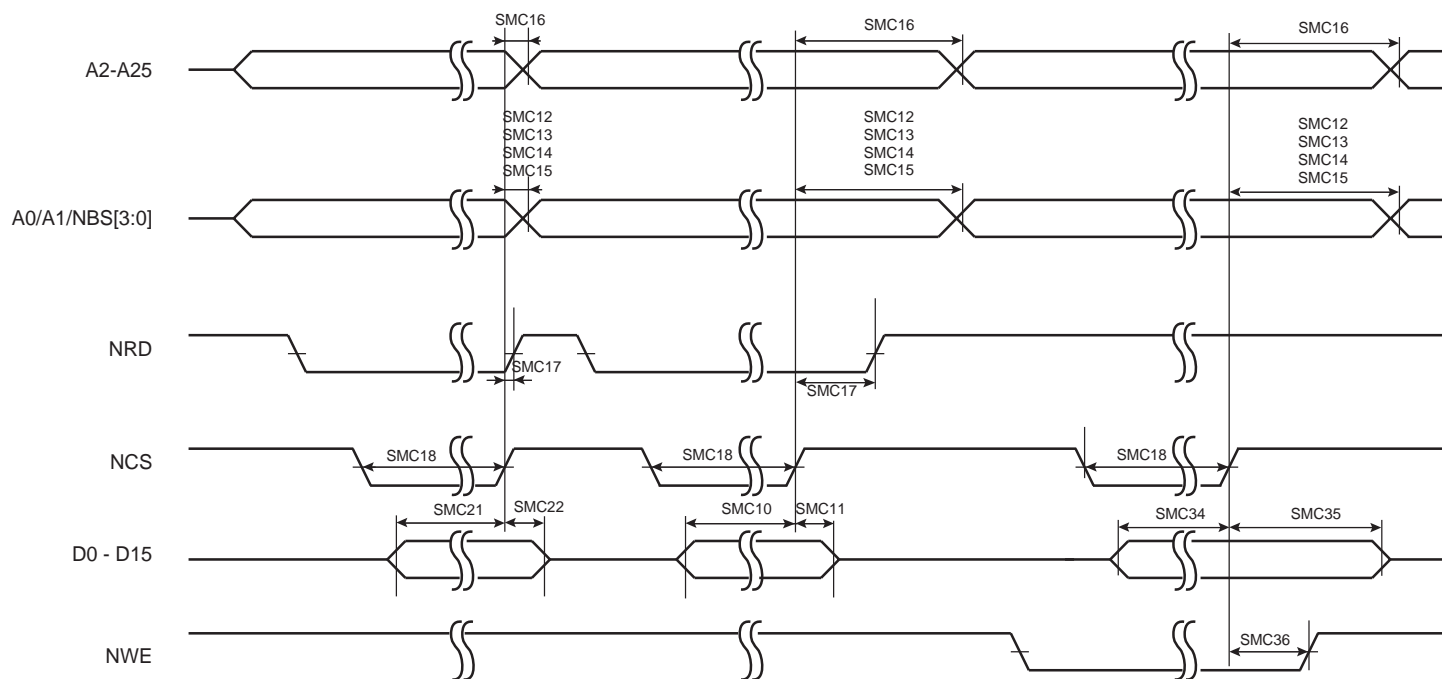
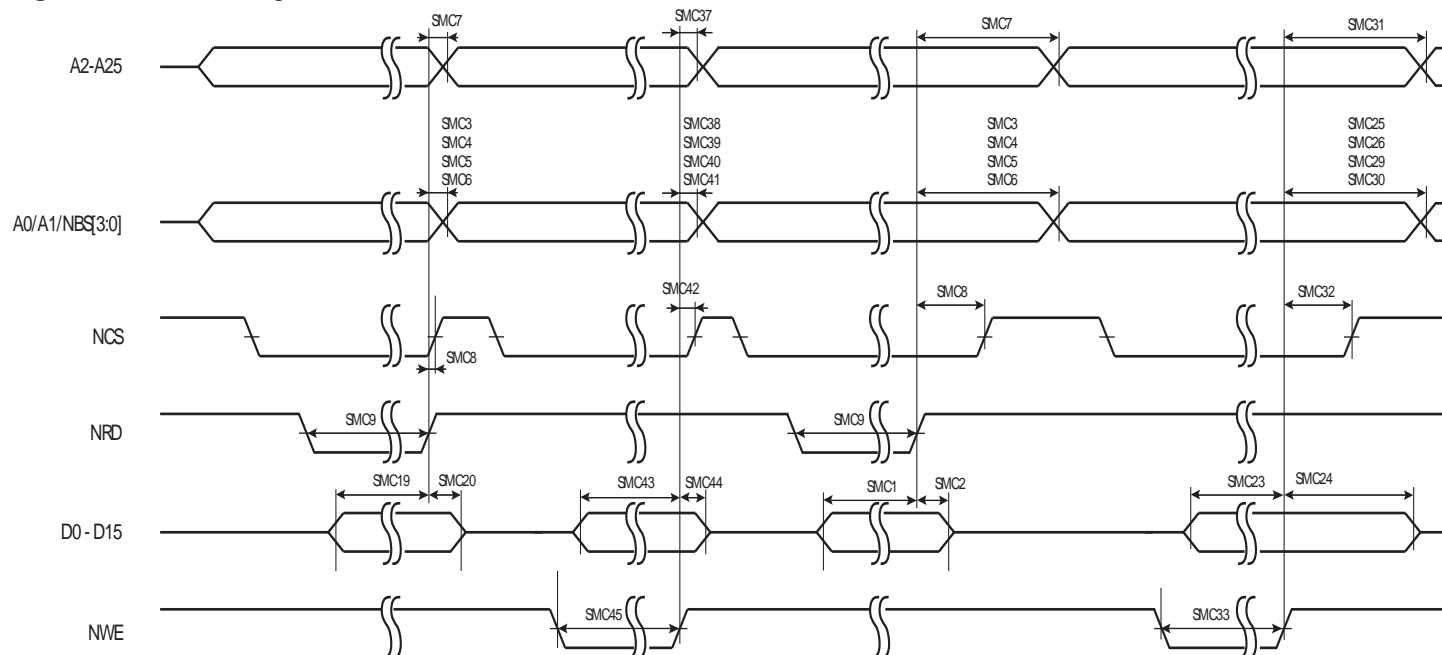

Figure 12-3. SMC Signals for NRD and NRW Controlled Accesses.



12.9.1 SDRAM Signals

These timings are given for 10 pF load on SDCK and 40 pF on other signals.

Table 12-27. SDRAM Clock Signal.

Symbol	Parameter	Max ⁽¹⁾	Units
$1/(t_{CPDCK})$	SDRAM Controller Clock Frequency	$1/(t_{cpCPU})$	MHz

Note: 1. The maximum frequency of the SDRAMC interface is the same as the max frequency for the HSB.

Table 12-28. SDRAM Clock Signal.

Symbol	Parameter	Min	Units
SDRAMC ₁	SDCKE High before SDCK Rising Edge	7.4	ns
SDRAMC ₂	SDCKE Low after SDCK Rising Edge	3.2	
SDRAMC ₃	SDCKE Low before SDCK Rising Edge	7	
SDRAMC ₄	SDCKE High after SDCK Rising Edge	2.9	
SDRAMC ₅	SDCS Low before SDCK Rising Edge	7.5	
SDRAMC ₆	SDCS High after SDCK Rising Edge	1.6	
SDRAMC ₇	RAS Low before SDCK Rising Edge	7.2	
SDRAMC ₈	RAS High after SDCK Rising Edge	2.3	
SDRAMC ₉	SDA10 Change before SDCK Rising Edge	7.6	
SDRAMC ₁₀	SDA10 Change after SDCK Rising Edge	1.9	

Table 12-28. SDRAM Clock Signal.

Symbol	Parameter	Min	Units
SDRAMC ₁₁	Address Change before SDCK Rising Edge	6.2	ns
SDRAMC ₁₂	Address Change after SDCK Rising Edge	2.2	
SDRAMC ₁₃	Bank Change before SDCK Rising Edge	6.3	
SDRAMC ₁₄	Bank Change after SDCK Rising Edge	2.4	
SDRAMC ₁₅	CAS Low before SDCK Rising Edge	7.4	
SDRAMC ₁₆	CAS High after SDCK Rising Edge	1.9	
SDRAMC ₁₇	DQM Change before SDCK Rising Edge	6.4	
SDRAMC ₁₈	DQM Change after SDCK Rising Edge	2.2	
SDRAMC ₁₉	D0-D15 in Setup before SDCK Rising Edge	9	
SDRAMC ₂₀	D0-D15 in Hold after SDCK Rising Edge	0	
SDRAMC ₂₃	SDWE Low before SDCK Rising Edge	7.6	
SDRAMC ₂₄	SDWE High after SDCK Rising Edge	1.8	
SDRAMC ₂₅	D0-D15 Out Valid before SDCK Rising Edge	7.1	
SDRAMC ₂₆	D0-D15 Out Valid after SDCK Rising Edge	1.5	

Figure 12-4. SDRAMC Signals relative to SDCK.

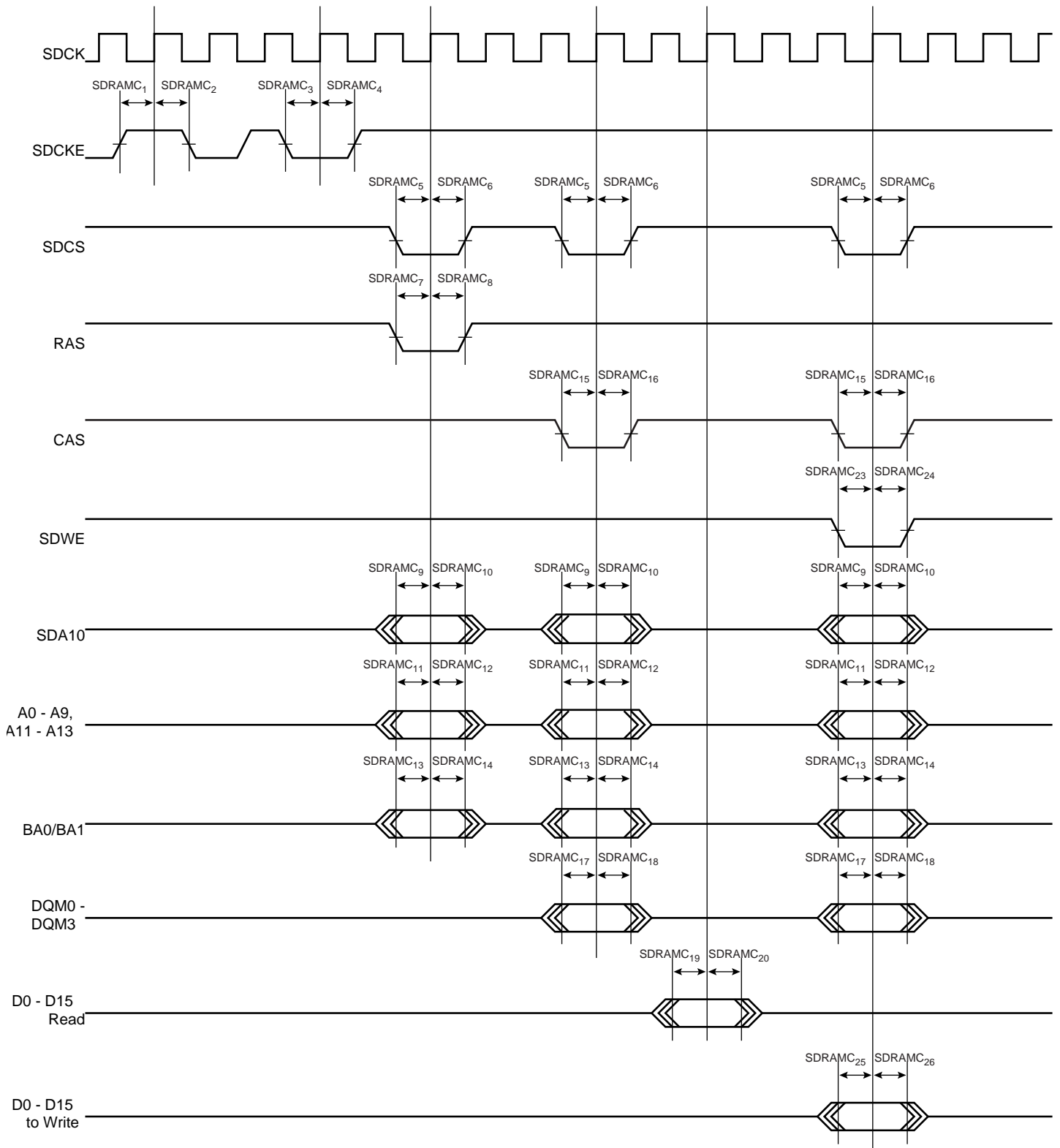

12.10 JTAG Timings

12.10.1 JTAG Interface Signals

Table 12-29. JTAG Interface Timing specification

Symbol	Parameter	Conditions	Min	Max	Units
JTAG ₀	TCK Low Half-period	(1)	6		ns
JTAG ₁	TCK High Half-period	(1)	3		ns
JTAG ₂	TCK Period	(1)	9		ns
JTAG ₃	TDI, TMS Setup before TCK High	(1)	1		ns
JTAG ₄	TDI, TMS Hold after TCK High	(1)	0		ns
JTAG ₅	TDO Hold Time	(1)	4		ns
JTAG ₆	TCK Low to TDO Valid	(1)		6	ns
JTAG ₇	Device Inputs Setup Time	(1)			ns
JTAG ₈	Device Inputs Hold Time	(1)			ns
JTAG ₉	Device Outputs Hold Time	(1)			ns
JTAG ₁₀	TCK to Device Outputs Valid	(1)			ns

Note: 1. V_{DDIO} from 3.0V to 3.6V, maximum external capacitor = 40pF

Figure 12-5. JTAG Interface Signals

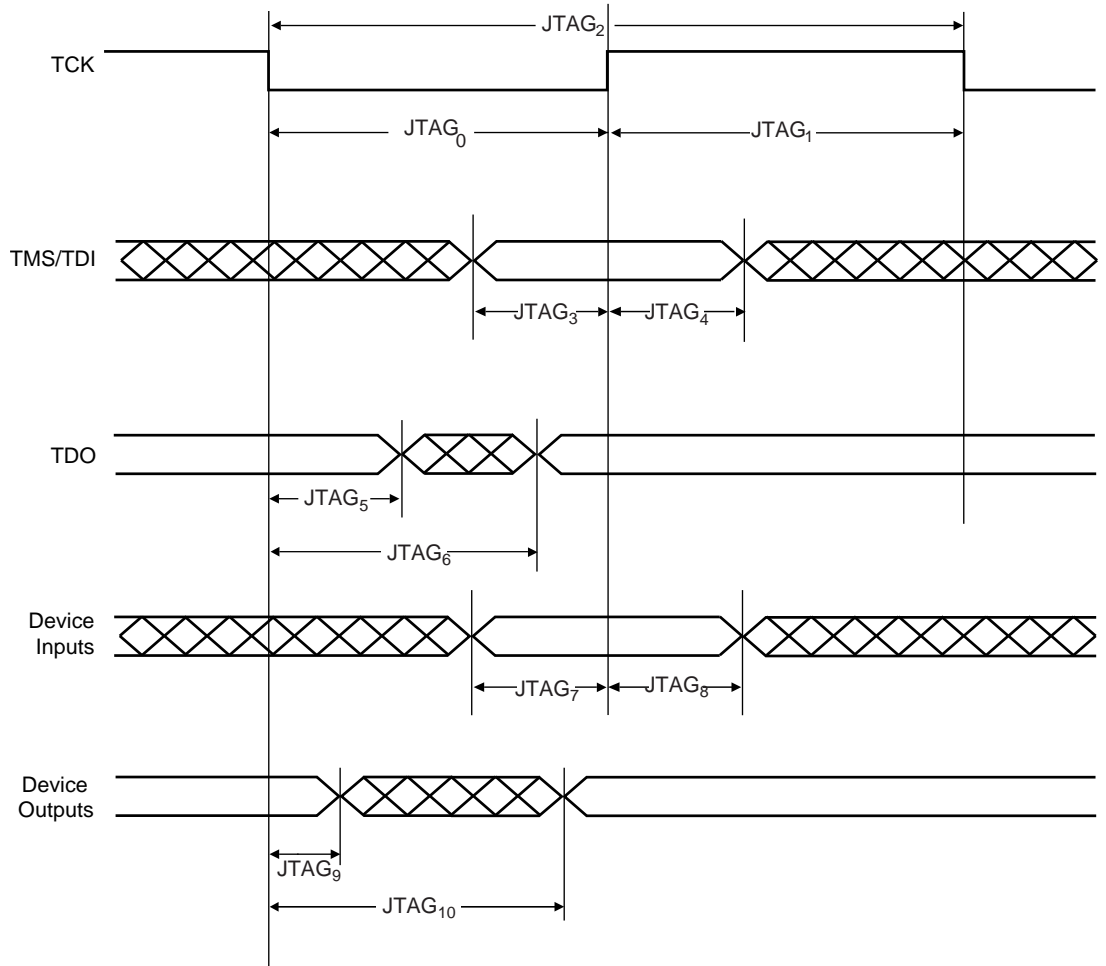

12.11 SPI Characteristics

Figure 12-6. SPI Master mode with (CPOL = NCPHA = 0) or (CPOL= NCPHA= 1)

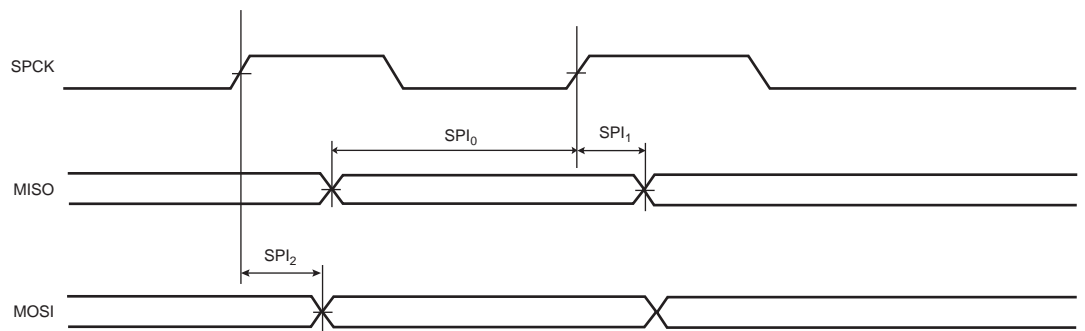

Figure 12-7. SPI Master mode with (CPOL=0 and NCPHA=1) or (CPOL=1 and NCPHA=0)

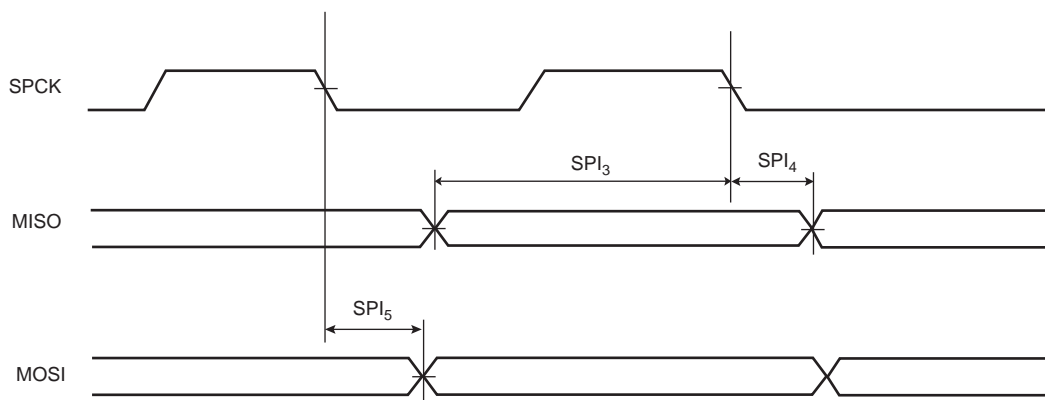

Figure 12-8. SPI Slave mode with (CPOL=0 and NCPHA=1) or (CPOL=1 and NCPHA=0)

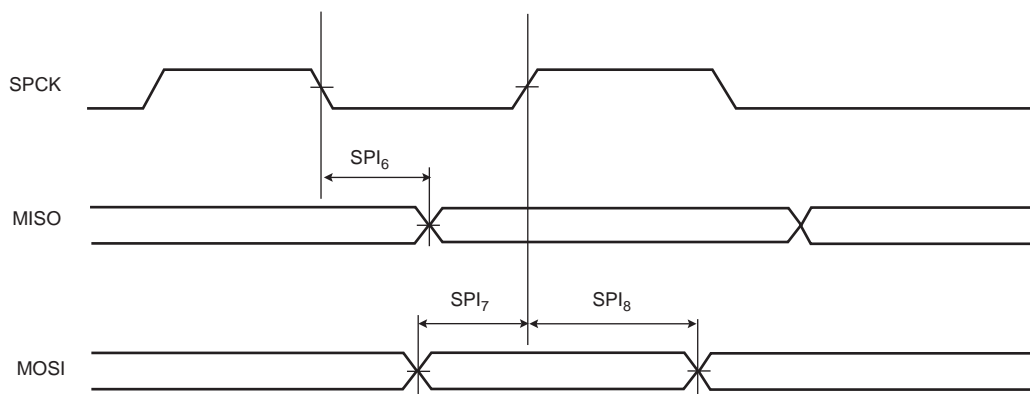

Figure 12-9. SPI Slave mode with (CPOL = NCPHA = 0) or (CPOL= NCPHA= 1)

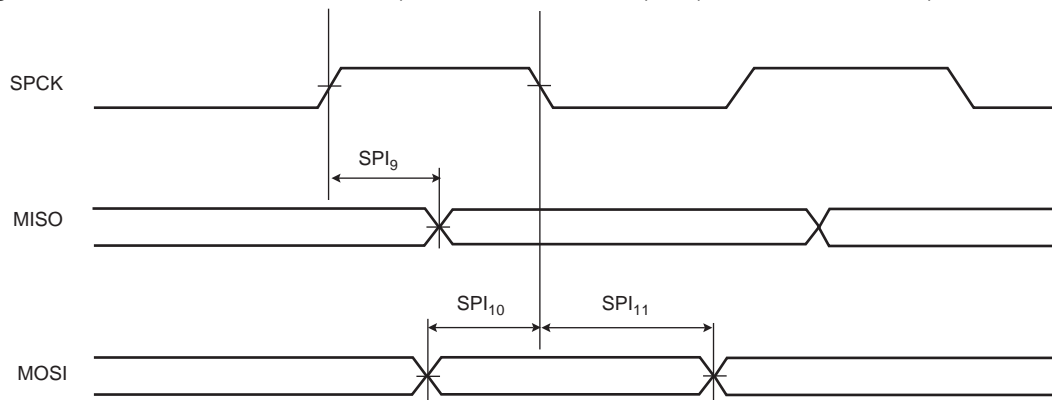

Table 12-30. SPI Timings

Symbol	Parameter	Conditions	Min	Max	Units
SPI ₀	MISO Setup time before SPCK rises (master)	3.3V domain ⁽¹⁾	22 + (t _{CPMCK})/2 ⁽²⁾		ns
SPI ₁	MISO Hold time after SPCK rises (master)	3.3V domain ⁽¹⁾	0		ns
SPI ₂	SPCK rising to MOSI Delay (master)	3.3V domain ⁽¹⁾		7	ns
SPI ₃	MISO Setup time before SPCK falls (master)	3.3V domain ⁽¹⁾	22 + (t _{CPMCK})/2 ⁽²⁾		ns
SPI ₄	MISO Hold time after SPCK falls (master)	3.3V domain ⁽¹⁾	0		ns
SPI ₅	SPCK falling to MOSI Delay (master)	3.3V domain ⁽¹⁾		7	ns
SPI ₆	SPCK falling to MISO Delay (slave)	3.3V domain ⁽¹⁾		26.5	ns
SPI ₇	MOSI Setup time before SPCK rises (slave)	3.3V domain ⁽¹⁾	0		ns
SPI ₈	MOSI Hold time after SPCK rises (slave)	3.3V domain ⁽¹⁾	1.5		ns
SPI ₉	SPCK rising to MISO Delay (slave)	3.3V domain ⁽¹⁾		27	ns
SPI ₁₀	MOSI Setup time before SPCK falls (slave)	3.3V domain ⁽¹⁾	0		ns
SPI ₁₁	MOSI Hold time after SPCK falls (slave)	3.3V domain ⁽¹⁾	1		ns

Notes: 1. 3.3V domain: V_{VDDIO} from 3.0V to 3.6V, maximum external capacitor = 40 pF.
 2. t_{CPMCK}: Master Clock period in ns.

12.12 MACB Characteristics

Table 12-31. Ethernet MAC Signals

Symbol	Parameter	Conditions	Min (ns)	Max (ns)
EMAC ₁	Setup for EMDIO from EMDC rising	Load: 20pF ⁽²⁾		
EMAC ₂	Hold for EMDIO from EMDC rising	Load: 20pF ⁽²⁾		
EMAC ₃	EMDIO toggling from EMDC falling	Load: 20pF ⁽²⁾		

Notes: 1. f: MCK frequency (MHz)
 2. V_{VDDIO} from 3.0V to 3.6V, maximum external capacitor = 20 pF

Table 12-32. Ethernet MAC MII Specific Signals

Symbol	Parameter	Conditions	Min (ns)	Max (ns)
EMAC ₄	Setup for ECOL from ETXCK rising	Load: 20pF ⁽¹⁾	3	
EMAC ₅	Hold for ECOL from ETXCK rising	Load: 20pF ⁽¹⁾	0	
EMAC ₆	Setup for ECRS from ETXCK rising	Load: 20pF ⁽¹⁾	3	
EMAC ₇	Hold for ECRS from ETXCK rising	Load: 20pF ⁽¹⁾	0	
EMAC ₈	ETXER toggling from ETXCK rising	Load: 20pF ⁽¹⁾		15
EMAC ₉	ETXEN toggling from ETXCK rising	Load: 20pF ⁽¹⁾		15
EMAC ₁₀	ETX toggling from ETXCK rising	Load: 20pF ⁽¹⁾		15
EMAC ₁₁	Setup for ERX from ERXCK	Load: 20pF ⁽¹⁾	1	

Table 12-32. Ethernet MAC MII Specific Signals

Symbol	Parameter	Conditions	Min (ns)	Max (ns)
EMAC ₁₂	Hold for ERX from ERXCK	Load: 20pF ⁽¹⁾	1.5	
EMAC ₁₃	Setup for ERXER from ERXCK	Load: 20pF ⁽¹⁾	1	
EMAC ₁₄	Hold for ERXER from ERXCK	Load: 20pF ⁽¹⁾	0.5	
EMAC ₁₅	Setup for ERXDV from ERXCK	Load: 20pF ⁽¹⁾	1.5	
EMAC ₁₆	Hold for ERXDV from ERXCK	Load: 20pF ⁽¹⁾	1	

Note: 1. V_{VDDIO} from 3.0V to 3.6V, maximum external capacitor = 20 pF

Figure 12-10. Ethernet MAC MII Mode

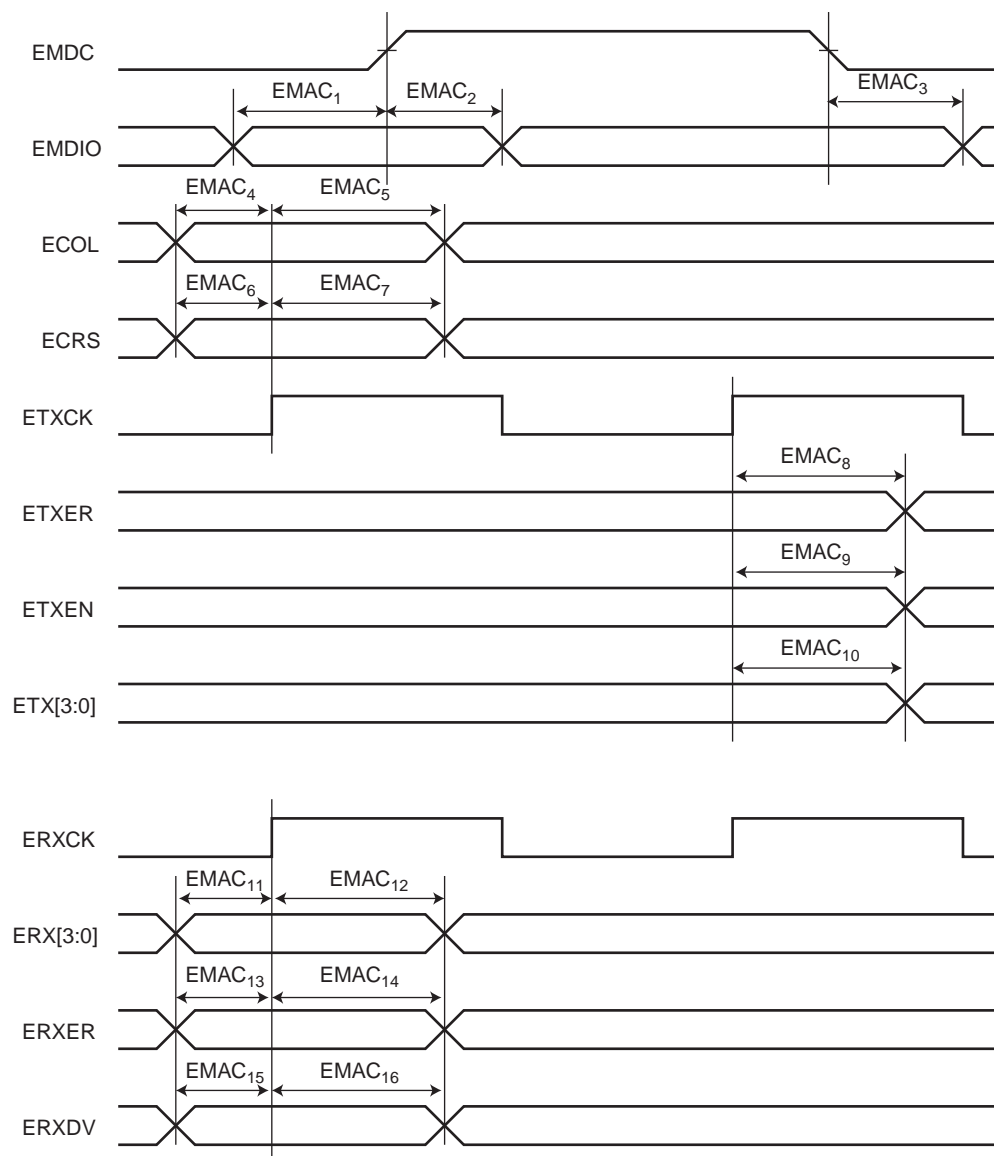
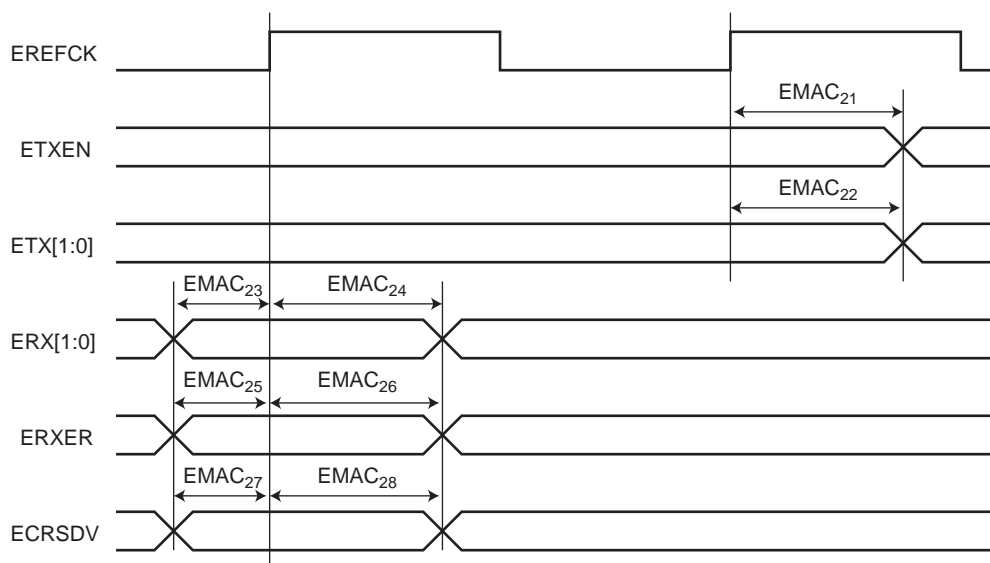

Table 12-33. Ethernet MAC RMII Specific Signals

Symbol	Parameter	Min (ns)	Max (ns)
EMAC ₂₁	ETXEN toggling from EREFCK rising	7	14.5
EMAC ₂₂	ETX toggling from EREFCK rising	7	14.7
EMAC ₂₃	Setup for ERX from EREFCK	1.5	
EMAC ₂₄	Hold for ERX from EREFCK	0	
EMAC ₂₅	Setup for ERXER from EREFCK	1.5	
EMAC ₂₆	Hold for ERXER from EREFCK	0	
EMAC ₂₇	Setup for ECRSDV from EREFCK	1.5	
EMAC ₂₈	Hold for ECRSDV from EREFCK	0	

Figure 12-11. Ethernet MAC RMII Mode



12.13 Flash Characteristics

The following table gives the device maximum operating frequency depending on the field FWS of the Flash FSR register. This field defines the number of wait states required to access the Flash Memory.

Table 12-34. Flash Wait States

FWS	Read Operations	Maximum Operating Frequency (MHz)
0	1 cycle	33
1	2 cycles	66

Table 12-35. Programming Time

Temperature Operating Range Part	Page Programming Time (ms)	Chip Erase Time (ms)
Industrial	4	4
Automotive	16	16

13. Mechanical Characteristics

13.1 Thermal Considerations

13.1.1 Thermal Data

Table 13-1 summarizes the thermal resistance data depending on the package.

Table 13-1. Thermal Resistance Data

Symbol	Parameter	Condition	Package	Typ	Unit
θ_{JA}	Junction-to-ambient thermal resistance	Still Air	TQFP100	43.4	°C/W
θ_{JC}	Junction-to-case thermal resistance		TQFP100	5.5	
θ_{JA}	Junction-to-ambient thermal resistance	Still Air	LQFP144	39.8	°C/W
θ_{JC}	Junction-to-case thermal resistance		LQFP144	8.9	

13.1.2 Junction Temperature

The average chip-junction temperature, T_J , in °C can be obtained from the following:

1. $T_J = T_A + (P_D \times \theta_{JA})$
2. $T_J = T_A + (P_D \times (\theta_{HEATSINK} + \theta_{JC}))$

where:

- θ_{JA} = package thermal resistance, Junction-to-ambient (°C/W), provided in [Table 13-1 on page 64](#).
- θ_{JC} = package thermal resistance, Junction-to-case thermal resistance (°C/W), provided in [Table 13-1 on page 64](#).
- $\theta_{HEAT\ SINK}$ = cooling device thermal resistance (°C/W), provided in the device datasheet.
- P_D = device power consumption (W) estimated from data provided in the section "[Power Consumption](#)" on page 44.
- T_A = ambient temperature (°C).

From the first equation, the user can derive the estimated lifetime of the chip and decide if a cooling device is necessary or not. If a cooling device is to be fitted on the chip, the second equation should be used to compute the resulting average chip-junction temperature T_J in °C.

13.2 Package Drawings

Figure 13-1. TQFP-100 package drawing

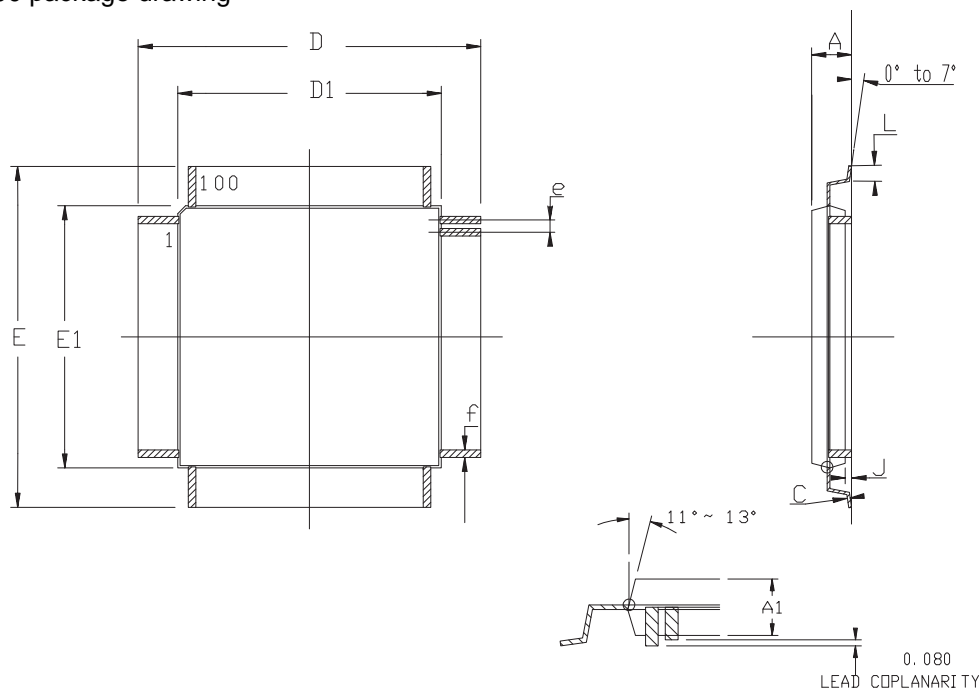

	MM		INCH	
	Min	Max	Min	Max
A	----	1.20	----	.047
A1	0.95	1.05	.037	.041
C	0.09	0.20	.004	.008
D	16.00 BSC		.630 BSC	
D1	14.00 BSC		.551 BSC	
E	16.00 BSC		.630 BSC	
E1	14.00 BSC		.551 BSC	
J	0.05	0.15	.002	.006
L	0.45	0.75	.018	.030
e	0.50 BSC		.020 BSC	
f	0.17	0.27	.007	.011

Table 13-2. Device and Package Maximum Weight

500	mg
-----	----

Table 13-3. Package Characteristics

Moisture Sensitivity Level	Jdec J-STD0-20D - MSL 3
----------------------------	-------------------------

Table 13-4. Package Reference

JEDEC Drawing Reference	MS-026
JESD97 Classification	E3

Figure 13-2. LQFP-144 package drawing

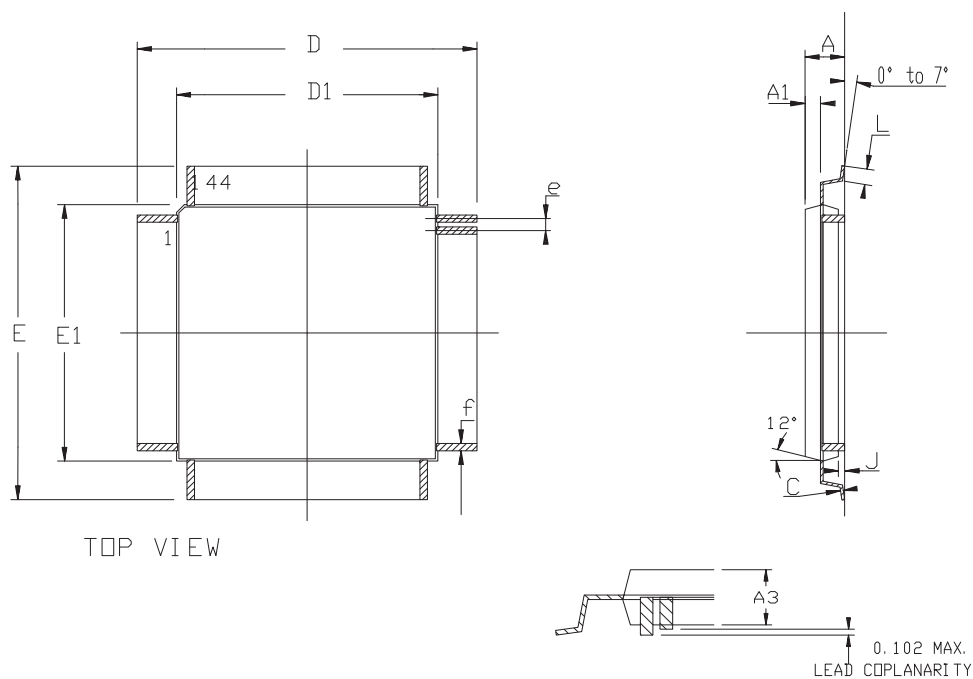

	MM		INCH	
	Min	Max	Min	Max
A	-	1.60	-	.063
C	0.09	0.20	.004	.008
A3	1.35	1.45	.053	.057
D	21.90	22.10	.862	.870
D1	19.90	20.10	.783	.791
E	21.90	22.10	.862	.870
E1	19.90	20.10	.783	.791
J	0.05	0.15	.002	.006
L	0.45	0.75	.018	.030
e	0.50 BSC		.0197 BSC	
f	0.22 BSC		.009 BSC	

Table 13-5. Device and Package Maximum Weight

1300	mg
------	----

Table 13-6. Package Characteristics

Moisture Sensitivity Level	Jdec J-STD0-20D - MSL 3
----------------------------	-------------------------

Table 13-7. Package Reference

JEDEC Drawing Reference	MS-026
JESD97 Classification	E3

Figure 13-3. FFBGA-144 package drawing

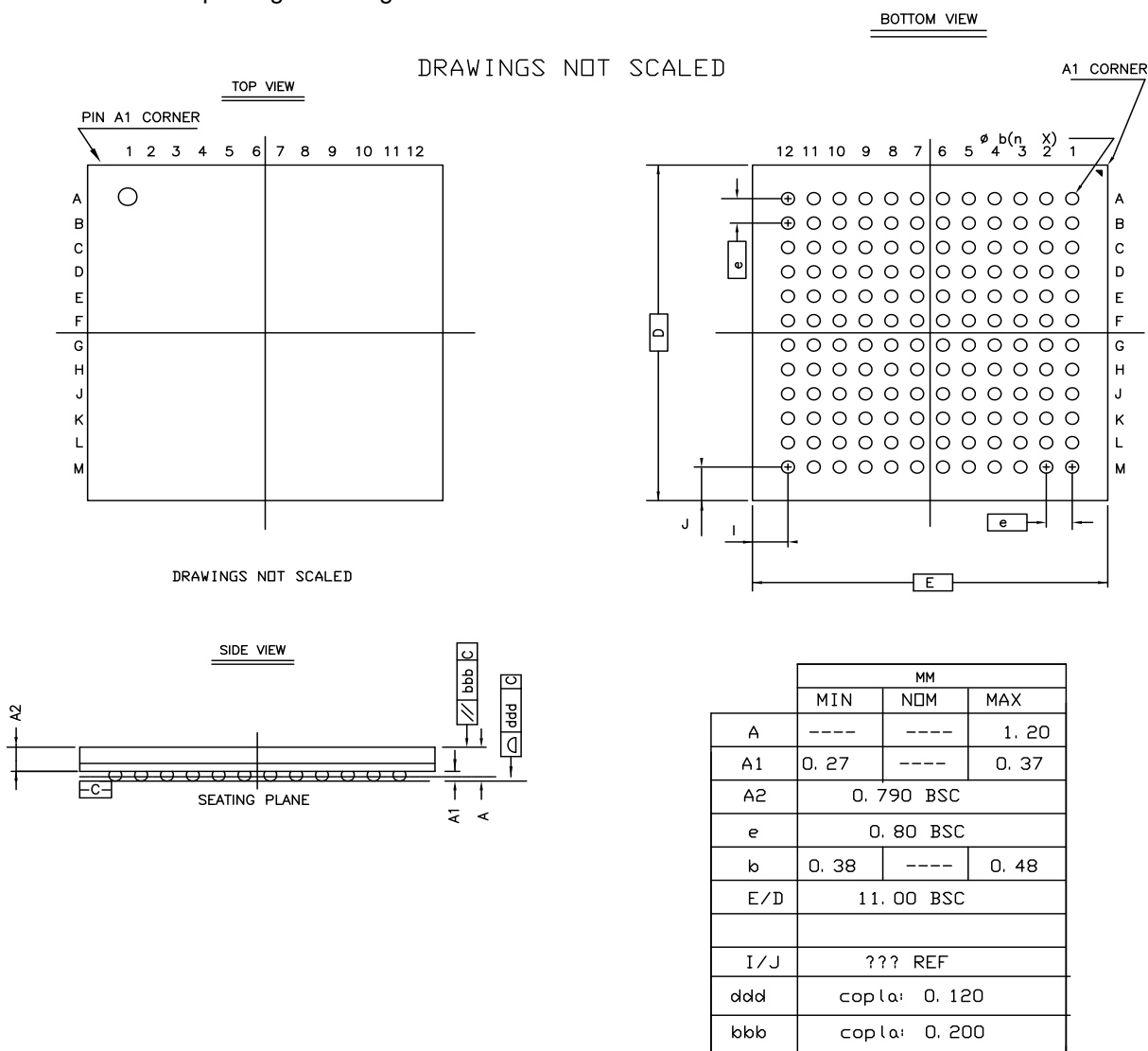

Table 13-8. Device and Package Maximum Weight

1300	mg
------	----

Table 13-9. Package Characteristics

Moisture Sensitivity Level	MSL3
----------------------------	------

Table 13-10. Package Reference

JEDEC Drawing Reference	MS-026
JESD97 Classification	E3

13.3 Soldering Profile

Table 13-11 gives the recommended soldering profile from J-STD-20.

Table 13-11. Soldering Profile

Profile Feature	Green Package
Average Ramp-up Rate (217°C to Peak)	3°C/sec
Preheat Temperature 175°C ±25°C	Min. 150 °C, Max. 200 °C
Time Maintained Above 217°C	60-150 sec
Time within 5-C of Actual Peak Temperature	30 sec
Peak Temperature Range	260 °C
Ramp-down Rate	6 °C/sec
Time 25-C to Peak Temperature	Max. 8 minutes

Note: It is recommended to apply a soldering temperature higher than 250°C. A maximum of three reflow passes is allowed per component.

14. Ordering Information

Table 14-1. Ordering Information

Device	Ordering Code	Package	Conditioning	Temperature Operating Range
AT32UC3A0512	AT32UC3A0512-ALUT	144 LQFP	Tray	Industrial (-40-C to 85-C)
	AT32UC3A0512-ALUR	144 LQFP	Reel	Industrial (-40-C to 85-C)
	AT32UC3A0512-ALTR	144 LQFP	Reel	Automotive (-40-C to 85-C)
	AT32UC3A0512-ALTT	144 LQFP	Tray	Automotive (-40-C to 85-C)
	AT32UC3A0512-ALTES	144 LQFP	Tray	Automotive (-40-C to 85-C) samples
	AT32UC3A0512-CTUT	144 FFBGA	Tray	Industrial (-40-C to 85-C)
	AT32UC3A0512-CTUR	144 FFBGA	Reel	Industrial (-40-C to 85-C)
AT32UC3A0256	AT32UC3A0256-ALUT	144 LQFP	Tray	Industrial (-40-C to 85-C)
	AT32UC3A0256-ALUR	144 LQFP	Reel	Industrial (-40-C to 85-C)
	AT32UC3A0256-CTUT	144 FFBGA	Tray	Industrial (-40-C to 85-C)
	AT32UC3A0256-CTUR	144 FFBGA	Reel	Industrial (-40-C to 85-C)
AT32UC3A0128	AT32UC3A0128-ALUT	144 LQFP	Tray	Industrial (-40-C to 85-C)
	AT32UC3A0128-ALUR	144 LQFP	Reel	Industrial (-40-C to 85-C)
	AT32UC3A0128-CTUT	144 FFBGA	Tray	Industrial (-40-C to 85-C)
	AT32UC3A0128-CTUR	144 FFBGA	Reel	Industrial (-40-C to 85-C)
AT32UC3A1512	AT32UC3A1512-AUT	100 TQFP	Tray	Industrial (-40-C to 85-C)
	AT32UC3A1512-AUR	100 TQFP	Reel	Industrial (-40-C to 85-C)
AT32UC3A1256	AT32UC3A1256-AUT	100 TQFP	Tray	Industrial (-40-C to 85-C)
	AT32UC3A1256-AUR	100 TQFP	Reel	Industrial (-40-C to 85-C)
AT32UC3A1128	AT32UC3A1128-AUT	100 TQFP	Tray	Industrial (-40-C to 85-C)
	AT32UC3A1128-AUR	100 TQFP	Reel	Industrial (-40-C to 85-C)

14.1 Automotive Quality Grade

The AT32UC3A have been developed and manufactured according to the most stringent requirements of the international standard ISO-TS-16949. This data sheet will contain limit values extracted from the results of extensive characterization (Temperature and Voltage). The quality and reliability of the AT32UC3A is verified during regular product qualification as per AEC-Q100 grade 3.

As indicated in the ordering information paragraph, the product is available in only one temperature grade T: -40°C / + 85°C.

15. Errata

All industrial parts labelled with -UES (engineering samples) are revision E parts.

15.1 Rev. K, L, M

15.1.1 PWM

1. PWM channel interrupt enabling triggers an interrupt

When enabling a PWM channel that is configured with center aligned period (CALG=1), an interrupt is signalled.

Fix/Workaround

When using center aligned mode, enable the channel and read the status before channel interrupt is enabled.

2. PWM counter restarts at 0x0001

The PWM counter restarts at 0x0001 and not 0x0000 as specified. Because of this the first PWM period has one more clock cycle.

Fix/Workaround

- The first period is 0x0000, 0x0001, ..., period
- Consecutive periods are 0x0001, 0x0002, ..., period

3. PWM update period to a 0 value does not work

It is impossible to update a period equal to 0 by the using the PWM update register (PWM_CUPD).

Fix/Workaround

Do not update the PWM_CUPD register with a value equal to 0.

15.1.2 ADC

1. Sleep Mode activation needs additional A to D conversion

If the ADC sleep mode is activated when the ADC is idle the ADC will not enter sleep mode before after the next AD conversion.

Fix/Workaround

Activate the sleep mode in the mode register and then perform an AD conversion.

15.1.3 SPI

1. SPI Slave / PDCA transfer: no TX UNDERRUN flag

There is no TX UNDERRUN flag available, therefore in SPI slave mode, there is no way to be informed of a character lost in transmission.

Fix/Workaround

For PDCA transfer: none.

2. SPI FDIV option does not work

Selecting clock signal using FDIV = 1 does not work as specified.

Fix/Workaround

Do not set FDIV = 1.

3. SPI Bad Serial Clock Generation on 2nd chip_select when SCBR = 1, CPOL=1 and NCPHA=0

When multiple CS are in use, if one of the baudrate equals to 1 and one of the others doesn't equal to 1, and CPOL=1 and CPHA=0, then an additional pulse will be generated on SCK.

Fix/workaround

When multiple CS are in use, if one of the baudrate equals 1, the other must also equal 1 if CPOL=1 and CPHA=0.

4. SPI Glitch on RXREADY flag in slave mode when enabling the SPI or during the first transfer

In slave mode, the SPI can generate a false RXREADY signal during enabling of the SPI or during the first transfer.

Fix/Workaround

1. Set slave mode, set required CPOL/CPHA.
2. Enable SPI.
3. Set the polarity CPOL of the line in the opposite value of the required one.
4. Set the polarity CPOL to the required one.
5. Read the RXHOLDING register.

Transfers can now begin and RXREADY will now behave as expected.

5. SPI Disable does not work in Slave mode

Fix/workaround

Read the last received data then perform a Software reset.

15.1.4 Power Manager

1. If the BOD level is higher than VDDCORE, the part is constantly under reset

If the BOD level is set to a value higher than VDDCORE and enabled by fuses, the part will be in constant reset.

Fix/Workaround

Apply an external voltage on VDDCORE that is higher than the BOD level and is lower than VDDCORE max and disable the BOD.

15.1.5 PDCA

1. Wrong PDCA behavior when using two PDCA channels with the same PID.

Fix/Workaround

The same PID should not be assigned to more than one channel.

15.1.6 TWI

1. The TWI RXRDY flag in SR register is not reset when a software reset is performed.

Fix/Workaround

After a Software Reset, the register TWI RHR must be read.

15.1.7 USART

1. ISO7816 info register US_NER cannot be read

The NER register always returns zero.

Fix/Workaround

None

15.1.8 Processor and Architecture

1. LDM instruction with PC in the register list and without ++ increments R_p



For LDM with PC in the register list: the instruction behaves as if the ++ field is always set, ie the pointer is always updated. This happens even if the ++ field is cleared. Specifically, the increment of the pointer is done in parallel with the testing of R12.

Fix/Workaround

None.

15.2 Rev. J

15.2.1 PWM

1. PWM channel interrupt enabling triggers an interrupt

When enabling a PWM channel that is configured with center aligned period (CALG=1), an interrupt is signalled.

Fix/Workaround

When using center aligned mode, enable the channel and read the status before channel interrupt is enabled.

2. PWM counter restarts at 0x0001

The PWM counter restarts at 0x0001 and not 0x0000 as specified. Because of this the first PWM period has one more clock cycle.

Fix/Workaround

- The first period is 0x0000, 0x0001, ..., period
- Consecutive periods are 0x0001, 0x0002, ..., period

3. PWM update period to a 0 value does not work

It is impossible to update a period equal to 0 by the using the PWM update register (PWM_CUPD).

Fix/Workaround

Do not update the PWM_CUPD register with a value equal to 0.

15.2.2 ADC

1. Sleep Mode activation needs additional A to D conversion

If the ADC sleep mode is activated when the ADC is idle the ADC will not enter sleep mode before after the next AD conversion.

Fix/Workaround

Activate the sleep mode in the mode register and then perform an AD conversion.

15.2.3 SPI

1. SPI Slave / PDCA transfer: no TX UNDERRUN flag

There is no TX UNDERRUN flag available, therefore in SPI slave mode, there is no way to be informed of a character lost in transmission.

Fix/Workaround

For PDCA transfer: none.

2. SPI FDIV option does not work

Selecting clock signal using FDIV = 1 does not work as specified.

Fix/Workaround

Do not set FDIV = 1.

3. SPI Bad Serial Clock Generation on 2nd chip_select when SCBR = 1, CPOL=1 and NCPHA=0

When multiple CS are in use, if one of the baudrate equals to 1 and one of the others doesn't equal to 1, and CPOL=1 and CPHA=0, then an additional pulse will be generated on SCK.

Fix/workaround



When multiple CS are in use, if one of the baudrate equals 1, the other must also equal 1 if CPOL=1 and CPHA=0.

4. SPI Glitch on RXREADY flag in slave mode when enabling the SPI or during the first transfer

In slave mode, the SPI can generate a false RXREADY signal during enabling of the SPI or during the first transfer.

Fix/Workaround

1. Set slave mode, set required CPOL/CPHA.
2. Enable SPI.
3. Set the polarity CPOL of the line in the opposite value of the required one.
4. Set the polarity CPOL to the required one.
5. Read the RXHOLDING register.

Transfers can now begin and RXREADY will now behave as expected.

5. SPI Disable does not work in Slave mode

Fix/workaround

Read the last received data then perform a Software reset.

15.2.4 Power Manager

1. If the BOD level is higher than VDDCORE, the part is constantly under reset

If the BOD level is set to a value higher than VDDCORE and enabled by fuses, the part will be in constant reset.

Fix/Workaround

Apply an external voltage on VDDCORE that is higher than the BOD level and is lower than VDDCORE max and disable the BOD.

15.2.5 PDCA

1. Wrong PDCA behavior when using two PDCA channels with the same PID.

Fix/Workaround

The same PID should not be assigned to more than one channel.

15.2.6 TWI

1. The TWI RXRDY flag in SR register is not reset when a software reset is performed.

Fix/Workaround

After a Software Reset, the register TWI RHR must be read.

15.2.7 SDRAMC

1. Code execution from external SDRAM does not work

Code execution from SDRAM does not work.

Fix/Workaround

Do not run code from SDRAM.

15.2.8 GPIO

1. PA29 (TWI SDA) and PA30 (TWI SCL) GPIO VIH (input high voltage) is 3.6V max instead of 5V tolerant

The following GPIOs are not 5V tolerant : PA29 and PA30.

Fix/Workaround



15.2.9 USART

None.

1. **ISO7816 info register US_NER cannot be read**

The NER register always returns zero.

Fix/Workaround

None

15.2.10 Processor and Architecture

1. **LDM instruction with PC in the register list and without ++ increments Rp**

For LDM with PC in the register list: the instruction behaves as if the ++ field is always set, ie the pointer is always updated. This happens even if the ++ field is cleared. Specifically, the increment of the pointer is done in parallel with the testing of R12.

Fix/Workaround

None.

2. **RETE instruction does not clear SREG[L] from interrupts.**

The RETE instruction clears SREG[L] as expected from exceptions.

Fix/Workaround

When using the STCOND instruction, clear SREG[L] in the stacked value of SR before returning from interrupts with RETE.

3. **Exceptions when system stack is protected by MPU**

RETS behaves incorrectly when MPU is enabled and MPU is configured so that system stack is not readable in unprivileged mode.

Fix/Workaround

Workaround 1: Make system stack readable in unprivileged mode,

or

Workaround 2: Return from supervisor mode using rete instead of rets. This requires :

1. Changing the mode bits from 001b to 110b before issuing the instruction. Updating the mode bits to the desired value must be done using a single mtsr instruction so it is done atomically. Even if this step is described in general as not safe in the UC technical reference guide, it is safe in this very specific case.

2. Execute the RETE instruction.

15.3 Rev. I

15.3.1 PWM

1. PWM channel interrupt enabling triggers an interrupt

When enabling a PWM channel that is configured with center aligned period (CALG=1), an interrupt is signalled.

Fix/Workaround

When using center aligned mode, enable the channel and read the status before channel interrupt is enabled.

2. PWM counter restarts at 0x0001

The PWM counter restarts at 0x0001 and not 0x0000 as specified. Because of this the first PWM period has one more clock cycle.

Fix/Workaround

- The first period is 0x0000, 0x0001, ..., period
- Consecutive periods are 0x0001, 0x0002, ..., period

3. PWM update period to a 0 value does not work

It is impossible to update a period equal to 0 by the using the PWM update register (PWM_CUPD).

Fix/Workaround

Do not update the PWM_CUPD register with a value equal to 0.

15.3.2 ADC

1. Sleep Mode activation needs additional A to D conversion

If the ADC sleep mode is activated when the ADC is idle the ADC will not enter sleep mode before after the next AD conversion.

Fix/Workaround

Activate the sleep mode in the mode register and then perform an AD conversion.

15.3.3 SPI

1. SPI Slave / PDCA transfer: no TX UNDERRUN flag

There is no TX UNDERRUN flag available, therefore in SPI slave mode, there is no way to be informed of a character lost in transmission.

Fix/Workaround

For PDCA transfer: none.

2. SPI FDIV option does not work

Selecting clock signal using FDIV = 1 does not work as specified.

Fix/Workaround

Do not set FDIV = 1.

3. SPI Bad Serial Clock Generation on 2nd chip_select when SCBR = 1, CPOL=1 and NCPHA=0

When multiple CS are in use, if one of the baudrate equals to 1 and one of the others doesn't equal to 1, and CPOL=1 and CPHA=0, then an additional pulse will be generated on SCK.

Fix/workaround

When multiple CS are in use, if one of the baudrate equals 1, the other must also equal 1 if CPOL=1 and CPHA=0.

4. **SPI Glitch on RXREADY flag in slave mode when enabling the SPI or during the first transfer**

In slave mode, the SPI can generate a false RXREADY signal during enabling of the SPI or during the first transfer.

Fix/Workaround

1. Set slave mode, set required CPOL/CPHA.
2. Enable SPI.
3. Set the polarity CPOL of the line in the opposite value of the required one.
4. Set the polarity CPOL to the required one.
5. Read the RXHOLDING register.

Transfers can now begin and RXREADY will now behave as expected.

5. **SPI Disable does not work in Slave mode**

Fix/workaround

Read the last received data then perform a Software reset.

15.3.4 Power Manager

1. **If the BOD level is higher than VDDCORE, the part is constantly under reset**

If the BOD level is set to a value higher than VDDCORE and enabled by fuses, the part will be in constant reset.

Fix/Workaround

Apply an external voltage on VDDCORE that is higher than the BOD level and is lower than VDDCORE max and disable the BOD.

15.3.5 Flashc

1. **On AT32UC3A0512 and AT32UC3A1512, corrupted read in flash after FLASHC WP, EP, EA, WUP, EUP commands may happen**

- After a FLASHC Write Page (WP) or Erase Page (EP) command applied to a page in a given half of the flash (first or last 256 kB of flash), reading (data read or code fetch) the other half of the flash may fail. This may lead to an exception or to other errors derived from this corrupted read access.

- After a FLASHC Erase All (EA) command, reading (data read or code fetch) the flash may fail. This may lead to an exception or to other errors derived from this corrupted read access.

- After a FLASHC Write User Page (WUP) or Erase User Page (EUP) command, reading (data read or code fetch) the second half (last 256 kB) of the flash may fail. This may lead to an exception or to other errors derived from this corrupted read access.

Fix/Workaround

Flashc WP, EP, EA, WUP, EUP commands: these commands must be issued from RAM or through the EBI. After these commands, read twice one flash page initialized to 00h in each half part of the flash.

15.3.6 PDCA

1. **Wrong PDCA behavior when using two PDCA channels with the same PID.**

Workaround/fix

The same PID should not be assigned to more than one channel.

15.3.7 GPIO

1. Some GPIO VIH (input high voltage) are 3.6V max instead of 5V tolerant

Only 11 GPIOs remain 5V tolerant (VIHmax=5V):PB01, PB02, PB03, PB10, PB19, PB20, PB21, PB22, PB23, PB27, PB28.

Workaround/fix

None.

15.3.8 USART

1. ISO7816 info register US_NER cannot be read

The NER register always returns zero.

Fix/Workaround

None.

15.3.9 TWI

1. The TWI RXRDY flag in SR register is not reset when a software reset is performed.

Fix/Workaround

After a Software Reset, the register TWI RHR must be read.

15.3.10 SDRAMC

1. Code execution from external SDRAM does not work

Code execution from SDRAM does not work.

Fix/Workaround

Do not run code from SDRAM.

15.3.11 Processor and Architecture

1. LDM instruction with PC in the register list and without ++ increments Rp

For LDM with PC in the register list: the instruction behaves as if the ++ field is always set, ie the pointer is always updated. This happens even if the ++ field is cleared. Specifically, the increment of the pointer is done in parallel with the testing of R12.

Fix/Workaround

None.

2. RETE instruction does not clear SREG[L] from interrupts.

The RETE instruction clears SREG[L] as expected from exceptions.

Fix/Workaround

When using the STCOND instruction, clear SREG[L] in the stacked value of SR before returning from interrupts with RETE.

3. Exceptions when system stack is protected by MPU

RETS behaves incorrectly when MPU is enabled and MPU is configured so that system stack is not readable in unprivileged mode.

Fix/Woraround

Workaround 1: Make system stack readable in unprivileged mode,
or

Workaround 2: Return from supervisor mode using rete instead of rets. This requires :

1. Changing the mode bits from 001b to 110b before issuing the instruction. Updating the mode bits to the desired value must be done using a single mtsr instruction so it is done atomically. Even if this step is described in general as not safe in the UC technical reference guide, it is safe in this very

specific case.
2. Execute the RETE instruction.

15.4 Rev. H

15.4.1 PWM

1. PWM channel interrupt enabling triggers an interrupt

When enabling a PWM channel that is configured with center aligned period (CALG=1), an interrupt is signalled.

Fix/Workaround

When using center aligned mode, enable the channel and read the status before channel interrupt is enabled.

2. PWM counter restarts at 0x0001

The PWM counter restarts at 0x0001 and not 0x0000 as specified. Because of this the first PWM period has one more clock cycle.

Fix/Workaround

- The first period is 0x0000, 0x0001, ..., period
- Consecutive periods are 0x0001, 0x0002, ..., period

3. PWM update period to a 0 value does not work

It is impossible to update a period equal to 0 by the using the PWM update register (PWM_CUPD).

Fix/Workaround

Do not update the PWM_CUPD register with a value equal to 0.

15.4.2 ADC

1. Sleep Mode activation needs additional A to D conversion

If the ADC sleep mode is activated when the ADC is idle the ADC will not enter sleep mode before after the next AD conversion.

Fix/Workaround

Activate the sleep mode in the mode register and then perform an AD conversion.

15.4.3 SPI

1. SPI Slave / PDCA transfer: no TX UNDERRUN flag

There is no TX UNDERRUN flag available, therefore in SPI slave mode, there is no way to be informed of a character lost in transmission.

Fix/Workaround

For PDCA transfer: none.

2. SPI FDIV option does not work

Selecting clock signal using FDIV = 1 does not work as specified.

Fix/Workaround

Do not set FDIV = 1

3. SPI disable does not work in SLAVE mode.

Fix/Workaround

Read the last received data, then perform a Software Reset.

4. SPI Bad Serial Clock Generation on 2nd chip_select when SCBR = 1, CPOL=1 and NCPHA=0

When multiple CS are in use, if one of the baudrate equals to 1 and one of the others doesn't equal to 1, and CPOL=1 and CPHA=0, then an additional pulse will be generated on SCK.

Fix/workaround

When multiple CS are in use, if one of the baudrate equals 1, the other must also equal 1 if CPOL=1 and CPHA=0.

5. SPI Glitch on RXREADY flag in slave mode when enabling the SPI or during the first transfer

In slave mode, the SPI can generate a false RXREADY signal during enabling of the SPI or during the first transfer.

Fix/Workaround

1. Set slave mode, set required CPOL/CPHA.
2. Enable SPI.
3. Set the polarity CPOL of the line in the opposite value of the required one.
4. Set the polarity CPOL to the required one.
5. Read the RXHOLDING register.

Transfers can now begin and RXREADY will now behave as expected.

6. SPI Disable does not work in Slave mode

Fix/workaround

Read the last received data then perform a Software reset.

15.4.4 Power Manager

1. Wrong reset causes when BOD is activated

Setting the BOD enable fuse will cause the Reset Cause Register to list BOD reset as the reset source even though the part was reset by another source.

Fix/Workaround

Do not set the BOD enable fuse, but activate the BOD as soon as your program starts.

2. If the BOD level is higher than VDDCORE, the part is constantly under reset

If the BOD level is set to a value higher than VDDCORE and enabled by fuses, the part will be in constant reset.

Fix/Workaround

Apply an external voltage on VDDCORE that is higher than the BOD level and is lower than VDDCORE max and disable the BOD.

15.4.5 FLASHC

1. On AT32UC3A0512 and AT32UC3A1512, corrupted read in flash after FLASHC WP, EP, EA, WUP, EUP commands may happen

- After a FLASHC Write Page (WP) or Erase Page (EP) command applied to a page in a given half of the flash (first or last 256 kB of flash), reading (data read or code fetch) the other half of the flash may fail. This may lead to an exception or to other errors derived from this corrupted read access.

- After a FLASHC Erase All (EA) command, reading (data read or code fetch) the flash may fail. This may lead to an exception or to other errors derived from this corrupted read access.

- After a FLASHC Write User Page (WUP) or Erase User Page (EUP) command, reading

(data read or code fetch) the second half (last 256 kB) of the flash may fail. This may lead to an exception or to other errors derived from this corrupted read access.

Fix/Workaround

Flashc WP, EP, EA, WUP, EUP commands: these commands must be issued from RAM or through the EBI. After these commands, read twice one flash page initialized to 00h in each half part of the flash.

15.4.6 PDCA

- 1. Wrong PDCA behavior when using two PDCA channels with the same PID.**

Workaround/fix

The same PID should not be assigned to more than one channel.

15.4.7 TWI

- 1. The TWI RXRDY flag in SR register is not reset when a software reset is performed.**

Fix/Workaround

After a Software Reset, the register TWI RHR must be read.

15.4.8 SDRAMC

- 1. Code execution from external SDRAM does not work**

Code execution from SDRAM does not work.

Fix/Workaround

Do not run code from SDRAM.

15.4.9 GPIO

- 1. Some GPIO VIH (input high voltage) are 3.6V max instead of 5V tolerant**

Only 11 GPIOs remain 5V tolerant ($V_{IHmax}=5V$): PB01, PB02, PB03, PB10, PB19, PB20, PB21, PB22, PB23, PB27, PB28.

Workaround/fix

None.

15.4.10 USART

- 1. ISO7816 info register US_NER cannot be read**

The NER register always returns zero.

Fix/Workaround

None.

15.4.11 Processor and Architecture

- 1. LDM instruction with PC in the register list and without ++ increments Rp**

For LDM with PC in the register list: the instruction behaves as if the ++ field is always set, ie the pointer is always updated. This happens even if the ++ field is cleared. Specifically, the increment of the pointer is done in parallel with the testing of R12.

Fix/Workaround

None.

- 2. RETE instruction does not clear SREG[L] from interrupts.**

The RETE instruction clears SREG[L] as expected from exceptions.

Fix/Workaround

When using the STCOND instruction, clear SREG[L] in the stacked value of SR before returning from interrupts with RETE.

- 3. Exceptions when system stack is protected by MPU**



RETS behaves incorrectly when MPU is enabled and MPU is configured so that system stack is not readable in unprivileged mode.

Fix/Workaround

Workaround 1: Make system stack readable in unprivileged mode,
or

Workaround 2: Return from supervisor mode using rete instead of rets. This requires :

1. Changing the mode bits from 001b to 110b before issuing the instruction. Updating the mode bits to the desired value must be done using a single mtsr instruction so it is done atomically. Even if this step is described in general as not safe in the UC technical reference guide, it is safe in this very specific case.
2. Execute the RETE instruction.

15.5 Rev. E

15.5.1 SPI

1. SPI FDIV option does not work

Selecting clock signal using $FDIV = 1$ does not work as specified.

Fix/Workaround

Do not set $FDIV = 1$.

2. SPI Slave / PDCA transfer: no TX UNDERRUN flag

There is no TX UNDERRUN flag available, therefore in SPI slave mode, there is no way to be informed of a character lost in transmission.

Fix/Workaround

For PDCA transfer: none.

3. SPI Bad serial clock generation on 2nd chip select when SCBR=1, CPOL=1 and CNCPHA=0

When multiple CS are in use, if one of the baudrate equals to 1 and one of the others doesn't equal to 1, and $CPOL=1$ and $CPHA=0$, then an additional pulse will be generated on SCK.

Fix/Workaround

When multiple CS are in use, if one of the baudrate equals to 1, the other must also equal 1 if $CPOL=1$ and $CPHA=0$.

4. SPI Glitch on RXREADY flag in slave mode when enabling the SPI or during the first transfer

In slave mode, the SPI can generate a false RXREADY signal during enabling of the SPI or during the first transfer.

Fix/Workaround

1. Set slave mode, set required CPOL/CPHA.
2. Enable SPI.
3. Set the polarity CPOL of the line in the opposite value of the required one.
4. Set the polarity CPOL to the required one.
5. Read the RXHOLDING register.

Transfers can now begin and RXREADY will now behave as expected.

5. SPI CSNAAT bit 2 in register CSR0...CSR3 is not available.**Fix/Workaround**

Do not use this bit.

6. SPI disable does not work in SLAVE mode.**Fix/Workaround**

Read the last received data, then perform a Software Reset.

7. SPI Bad Serial Clock Generation on 2nd chip_select when SCBR = 1, CPOL=1 and NCPHA=0

When multiple CS are in use, if one of the baudrate equals to 1 and one of the others doesn't equal to 1, and $CPOL=1$ and $CPHA=0$, then an additional pulse will be generated on SCK.



15.5.2 PWM

Fix/workaround

When multiple CS are in use, if one of the baudrate equals 1, the other must also equal 1 if CPOL=1 and CPHA=0.

1. PWM counter restarts at 0x0001

The PWM counter restarts at 0x0001 and not 0x0000 as specified. Because of this the first PWM period has one more clock cycle.

Fix/Workaround

- The first period is 0x0000, 0x0001, ..., period
- Consecutive periods are 0x0001, 0x0002, ..., period

2. PWM channel interrupt enabling triggers an interrupt

When enabling a PWM channel that is configured with center aligned period (CALG=1), an interrupt is signalled.

Fix/Workaround

When using center aligned mode, enable the channel and read the status before channel interrupt is enabled.

3. PWM update period to a 0 value does not work

It is impossible to update a period equal to 0 by the using the PWM update register (PWM_CUPD).

Fix/Workaround

Do not update the PWM_CUPD register with a value equal to 0.

4. PWM channel status may be wrong if disabled before a period has elapsed

Before a PWM period has elapsed, the read channel status may be wrong. The CHIDx-bit for a PWM channel in the PWM Enable Register will read '1' for one full PWM period even if the channel was disabled before the period elapsed. It will then read '0' as expected.

Fix/Workaround

Reading the PWM channel status of a disabled channel is only correct after a PWM period has elapsed.

15.5.3 SSC

1. SSC does not trigger RF when data is low

The SSC cannot transmit or receive data when CKS = CKDIV and CKO = none, in TCMR or RCMR respectively.

Fix/Workaround

Set CKO to a value that is not "none" and bypass the output of the TK/RK pin with the PIO.

2. SSC Data is not sent unless clock is set as output

The SSC cannot transmit or receive data when CKS = CKDIV and CKO = none, in TCMR or RCMR respectively.

Fix/Workaround

Set CKO to a value that is not "none" and bypass the output of the TK/RK pin with the PIO.



15.5.4 USB

1. USB No end of host reset signaled upon disconnection

In host mode, in case of an unexpected device disconnection whereas a usb reset is being sent by the usb controller, the UHCON.RESET bit may not be cleared by the hardware at the end of the reset.

Fix/Workaround

A software workaround consists in testing (by polling or interrupt) the disconnection (UHINT.DDISCI == 1) while waiting for the end of reset (UHCON.RESET == 0) to avoid being stuck.

2. USBFSM and UHADDR1/2/3 registers are not available.

Do not use USBFSM register.

Fix/Workaround

Do not use USBFSM register and use HCON[6:0] field instead for all the pipes.

15.5.5 Processor and Architecture

1. Incorrect Processor ID

The processor ID reads 0x01 and not 0x02 as it should.

Fix/Workaround

None.

2. Bus error should be masked in Debug mode

If a bus error occurs during debug mode, the processor will not respond to debug commands through the DINST register.

Fix/Workaround

A reset of the device will make the CPU respond to debug commands again.

3. Read Modify Write (RMW) instructions on data outside the internal RAM does not work.

Read Modify Write (RMW) instructions on data outside the internal RAM does not work.

Fix/Workaround

Do not perform RMW instructions on data outside the internal RAM.

4. CRC calculation of a locked device will calculate CRC for 512 kB of flash memory, even though the part has less flash.

Fix/Workaround

The flash address space is wrapping, so it is possible to use the CRC value by calculating CRC of the flash content concatenated with itself N times. Where N is 512 kB/flash size.

5. Need two NOPs instruction after instructions masking interrupts

The instructions following in the pipeline the instruction masking the interrupt through SR may behave abnormally.

Fix/Workaround

Place two NOPs instructions after each SSRF or MTSR instruction setting IxM or GM in SR.

- 6. **CPU Cycle Counter does not reset the COUNT system register on COMPARE match.**
The device revision E does not reset the COUNT system register on COMPARE match. In this revision, the COUNT register is clocked by the CPU clock, so when the CPU clock stops, so does incrementing of COUNT.

Fix/Workaround

None.

- 7. **Memory Protection Unit (MPU) is non functional.**

Fix/Workaround

Do not use the MPU.

- 8. **The following alternate GPIO function C are not available in revE**
MACB-WOL on GPIO9 (PA09), MACB-WOL on GPIO18 (PA18), USB-USB_ID on GPIO21 (PA21), USB-USB_VBOF on GPIO22 (PA22), and all function B and C on GPIO70 to GPIO101 (PX00 to PX39).

Fix/Workaround

Do not use these alternate B and C functions on the listed GPIO pins.

- 9. **Clock connection table on Rev E**

Here is the table of Rev E

Figure 15-1. Timer/Counter clock connections on RevE

Source	Name	Connection
Internal	TIMER_CLOCK1	32 KHz Oscillator
	TIMER_CLOCK2	PBA Clock / 4
	TIMER_CLOCK3	PBA Clock / 8
	TIMER_CLOCK4	PBA Clock / 16
	TIMER_CLOCK5	PBA Clock / 32
External	XC0	
	XC1	
	XC2	

- 10. **Local Bus fast GPIO not available in RevE.**

Fix/Workaround

Do not use on this silicon revision.

- 11. **Spurious interrupt may corrupt core SR mode to exception**

If the rules listed in the chapter 'Masking interrupt requests in peripheral modules' of the AVR32UC Technical Reference Manual are not followed, a spurious interrupt may occur. An interrupt context will be pushed onto the stack while the core SR mode will indicate an exception. A RETE instruction would then corrupt the stack..

Fix/Workaround

Follow the rules of the AVR32UC Technical Reference Manual. To increase software robustness, if an exception mode is detected at the beginning of an interrupt handler, change the stack interrupt context to an exception context and issue a RETE instruction.

12. CPU cannot operate on a divided slow clock (internal RC oscillator)

Fix/Workaround

Do not run the CPU on a divided slow clock.

13. LDM instruction with PC in the register list and without ++ increments Rp

For LDM with PC in the register list: the instruction behaves as if the ++ field is always set, ie the pointer is always updated. This happens even if the ++ field is cleared. Specifically, the increment of the pointer is done in parallel with the testing of R12.

Fix/Workaround

None.

14. RETE instruction does not clear SREG[L] from interrupts.

The RETE instruction clears SREG[L] as expected from exceptions.

Fix/Workaround

When using the STCOND instruction, clear SREG[L] in the stacked value of SR before returning from interrupts with RETE.

15. Exceptions when system stack is protected by MPU

RETS behaves incorrectly when MPU is enabled and MPU is configured so that system stack is not readable in unprivileged mode.

Fix/Woraround

Workaround 1: Make system stack readable in unprivileged mode,
or

Workaround 2: Return from supervisor mode using rete instead of rets. This requires :

1. Changing the mode bits from 001b to 110b before issuing the instruction. Updating the mode bits to the desired value must be done using a single mtsr instruction so it is done atomically. Even if this step is described in general as not safe in the UC technical reference guide, it is safe in this very specific case.

2. Execute the RETE instruction.

15.5.6 SDRAMC

1. Code execution from external SDRAM does not work

Code execution from SDRAM does not work.

Fix/Workaround

Do not run code from SDRAM.

2. SDRAM SDCKE rise at the same time as SDCK while exiting self-refresh mode

SDCKE rise at the same time as SDCK while exiting self-refresh mode.

Fix/Workaround

None.

15.5.7 USART

1. USART Manchester Encoder Not Working

Manchester encoding/decoding is not working.

Fix/Workaround

Do not use manchester encoding.

2. USART RXBREAK problem when no timeguard

In asynchronous mode the RXBREAK flag is not correctly handled when the timeguard is 0 and the break character is located just after the stop bit.

Fix/Workaround

If the NBSTOP is 1, timeguard should be different from 0.

3. USART Handshaking: 2 characters sent / CTS rises when TX

If CTS switches from 0 to 1 during the TX of a character, if the Holding register is not empty, the TXHOLDING is also transmitted.

Fix/Workaround

None.

4. USART PDC and TIMEGUARD not supported in MANCHESTER

Manchester encoding/decoding is not working.

Fix/Workaround

Do not use manchester encoding.

5. USART SPI mode is non functional on this revision.**Fix/Workaround**

Do not use the USART SPI mode.

6. DCD is active High instead of Low.

In modem mode the DCD signal is assumed to be active high by the USART, but should have been active low.

Fix/Workaround

Add an external inverter to the DCD line.

7. ISO7816 info register US_NER cannot be read

The NER register always returns zero.

Fix/Workaround

None.

15.5.8 Power Manager**1. Voltage regulator input and output is connected to VDDIO and VDDCORE inside the device**

The voltage regulator input and output is connected to VDDIO and VDDCORE respectively inside the device.

Fix/Workaround

Do not supply VDDCORE externally, as this supply will work in parallel with the regulator.

2. Wrong reset causes when BOD is activated

Setting the BOD enable fuse will cause the Reset Cause Register to list BOD reset as the reset source even though the part was reset by another source.

Fix/Workaround

Do not set the BOD enable fuse, but activate the BOD as soon as your program starts.

3. PLL0/1 Lock control does not work

Lock Control does not work for PLL0 and PLL1.



Fix/Workaround

In PLL0/1 Control register, the bit 7 should be set in order to prevent unexpected behaviour.

4. Peripheral Bus A maximum frequency is 33MHz instead of 66MHz.

Fix/Workaround

Do not set PBA frequency higher than 33 MHz.

5. PCx pins go low in stop mode

In sleep mode stop all PCx pins will be controlled by GPIO module instead of oscillators. This can cause drive contention on the XINx in worst case.

Fix/Workaround

Before entering stop mode set all PCx pins to input and GPIO controlled.

6. On some rare parts, the maximum HSB and CPU speed is 50MHz instead of 66MHz.

Fix/Workaround

Do not set the HSB/CPU speed higher than 50MHz when the firmware generate exceptions.

7. If the BOD level is higher than VDDCORE, the part is constantly under reset

If the BOD level is set to a value higher than VDDCORE and enabled by fuses, the part will be in constant reset.

Fix/Workaround

Apply an external voltage on VDDCORE that is higher than the BOD level and is lower than VDDCORE max and disable the BOD.

8. System Timer mask (Bit 16) of the PM CPUMASK register is not available.

Fix/Workaround

Do not use this bit.

15.5.9 HMatrix

1. HMatrix fixed priority arbitration does not work

Fixed priority arbitration does not work.

Fix/Workaround

Use Round-Robin arbitration instead.

15.5.10 ADC

1. ADC possible miss on DRDY when disabling a channel

The ADC does not work properly when more than one channel is enabled.

Fix/Workaround

Do not use the ADC with more than one channel enabled at a time.

2. ADC OVRE flag sometimes not reset on Status Register read

The OVRE flag does not clear properly if read simultaneously to an end of conversion.

Fix/Workaround

None.

3. Sleep Mode activation needs additional A to D conversion

If the ADC sleep mode is activated when the ADC is idle the ADC will not enter sleep mode before after the next AD conversion.

Fix/Workaround

Activate the sleep mode in the mode register and then perform an AD conversion.

15.5.11 ABDAC

1. **Audio Bitstream DAC is not functional.**

Fix/Workaround

Do not use the ABDAC on revE.

15.5.12 FLASHC

1. **The address of Flash General Purpose Fuse Register Low (FGPFRLO) is 0xFFFE140C on revE instead of 0xFFFE1410.**

Fix/Workaround

None.

2. **The command Quick Page Read User Page(QPRUP) is not functional.**

Fix/Workaround

None.

3. **PAGEN Semantic Field for Program GP Fuse Byte is WriteData[7:0], ByteAddress[1:0] on revision E instead of WriteData[7:0], ByteAddress[2:0].**

Fix/Workaround

None.

4. **On AT32UC3A0512 and AT32UC3A1512, corrupted read in flash after FLASHC WP, EP, EA, WUP, EUP commands may happen**

- After a FLASHC Write Page (WP) or Erase Page (EP) command applied to a page in a given half of the flash (first or last 256 kB of flash), reading (data read or code fetch) the other half of the flash may fail. This may lead to an exception or to other errors derived from this corrupted read access.

- After a FLASHC Erase All (EA) command, reading (data read or code fetch) the flash may fail. This may lead to an exception or to other errors derived from this corrupted read access.

- After a FLASHC Write User Page (WUP) or Erase User Page (EUP) command, reading (data read or code fetch) the second half (last 256 kB) of the flash may fail. This may lead to an exception or to other errors derived from this corrupted read access.

Fix/Workaround

Flashc WP, EP, EA, WUP, EUP commands: these commands must be issued from RAM or through the EBI. After these commands, read twice one flash page initialized to 00h in each half part of the flash.

15.5.13 RTC

1. **Writes to control (CTRL), top (TOP) and value (VAL) in the RTC are discarded if the RTC peripheral bus clock (PBA) is divided by a factor of four or more relative to the HSB clock.**

Fix/Workaround

Do not write to the RTC registers using the peripheral bus clock (PBA) divided by a factor of four or more relative to the HSB clock.

2. **The RTC CLKEN bit (bit number 16) of CTRL register is not available.**

Fix/Workaround

Do not use the CLKEN bit of the RTC on Rev E.

15.5.14 OCD

1. **Stalled memory access instruction writeback fails if followed by a HW breakpoint.**

Consider the following assembly code sequence:

A

B

If a hardware breakpoint is placed on instruction B, and instruction A is a memory access instruction, register file updates from instruction A can be discarded.

Fix/Workaround

Do not place hardware breakpoints, use software breakpoints instead.

Alternatively, place a hardware breakpoint on the instruction before the memory access instruction and then single step over the memory access instruction.

15.5.15 PDCA

1. **Wrong PDCA behavior when using two PDCA channels with the same PID.**

Workaround/fix

The same PID should not be assigned to more than one channel.

15.5.16 TWI

1. **The TWI RXRDY flag in SR register is not reset when a software reset is performed.**

Fix/Workaround

After a Software Reset, the register TWI RHR must be read.

16. Datasheet Revision History

Please note that the referring page numbers in this section are referred to this document. The referring revision in this section are referring to the document revision.

16.1 Rev. K – 01/12

1. Update "Errata" on page 70.
2. Update electrical characteristic in "DC Characteristics" on page 41.
3. Remove Preliminary from first page.

16.2 Rev. G – 01/09

1. Update "Errata" on page 70.
2. Update GPIO electrical characteristic in "DC Characteristics" on page 41.

16.3 Rev. F – 08/08

1. Add revision J to "Errata" on page 70.
2. Update DMIPS number in "Features" on page 1.

16.4 Rev. E – 04/08

1. Open Drain Mode removed from "General-Purpose Input/Output Controller (GPIO)" on page 151.

16.5 Rev. D – 04/08

1. Updated "Signal Description List" on page 8. Removed RXDN and TXDN from USART section.
2. Updated "Errata" on page 70. Rev G replaced by rev H.

16.6 Rev. C – 10/07

1. Updated "[Signal Description List](#)" on page 8. Removed RXDN and TXDN from USART section.
2. Updated "[Errata](#)" on page 70. Rev G replaced by rev H.

16.7 Rev. B – 10/07

1. Updated "[Features](#)" on page 1.
2. Update "[Blockdiagram](#)" on page 4 with local bus.
3. Updated "[Peripherals](#)" on page 34 with local bus.
4. Add SPI feature in "[Universal Synchronous/Asynchronous Receiver/Transmitter \(USART\)](#)" on page 315.
5. Updated "[USB On-The-Go Interface \(USBB\)](#)" on page 517.
6. Updated "[JTAG and Boundary Scan](#)" on page 750 with programming procedure .
7. Add description for silicon Rev G.

16.8 Rev. A – 03/07

1. Initial revision.

Table of Contents

1	<i>Description</i>	3
2	<i>Configuration Summary</i>	4
3	<i>Abbreviations</i>	4
4	<i>Blockdiagram</i>	5
	4.1 Processor and architecture	6
5	<i>Signals Description</i>	8
6	<i>Package and Pinout</i>	13
7	<i>Power Considerations</i>	17
	7.1 Power Supplies	17
	7.2 Voltage Regulator	18
	7.3 Analog-to-Digital Converter (A.D.C) reference.	19
8	<i>I/O Line Considerations</i>	20
	8.1 JTAG pins	20
	8.2 RESET_N pin	20
	8.3 TWI pins	20
	8.4 GPIO pins	20
9	<i>Memories</i>	21
	9.1 Embedded Memories	21
	9.2 Physical Memory Map	21
	9.3 Bus Matrix Connections	22
10	<i>Peripherals</i>	24
	10.1 Peripheral address map	24
	10.2 CPU Local Bus Mapping	25
	10.3 Interrupt Request Signal Map	27
	10.4 Clock Connections	29
	10.5 Nexus OCD AUX port connections	30
	10.6 PDC handshake signals	30
	10.7 Peripheral Multiplexing on I/O lines	31
	10.8 Oscillator Pinout	34
	10.9 USART Configuration	34
	10.10 GPIO	35

10.11	Peripheral overview	35
11	Boot Sequence	39
11.1	Starting of clocks	39
11.2	Fetching of initial instructions	39
12	Electrical Characteristics	40
12.1	Absolute Maximum Ratings*	40
12.2	DC Characteristics	41
12.3	Regulator characteristics	42
12.4	Analog characteristics	42
12.5	Power Consumption	44
12.6	Clock Characteristics	46
12.7	Crystal Oscillator Characteristic	47
12.8	ADC Characteristics	49
12.9	EBI Timings	51
12.10	JTAG Timings	57
12.11	SPI Characteristics	58
12.12	MACB Characteristics	60
12.13	Flash Characteristics	62
13	Mechanical Characteristics	64
13.1	Thermal Considerations	64
13.2	Package Drawings	65
13.3	Soldering Profile	68
14	Ordering Information	69
14.1	Automotive Quality Grade	69
15	Errata	70
15.1	Rev. K,L,M.....	70
15.2	Rev. J	73
15.3	Rev. I	76
15.4	Rev. H	80
15.5	Rev. E	84
16	Datasheet Revision History	93
16.1	Rev. K – 01/12	93
16.1	Rev. H – 03/09	93
16.2	Rev. G – 01/09	93
16.3	Rev. F – 08/08	93

16.4Rev. E – 04/08	93
16.5Rev. D – 04/08	93
16.6Rev. C – 10/07	94
16.7Rev. B – 10/07	94
16.8Rev. A – 03/07	94



Atmel Corporation

2325 Orchard Parkway
San Jose, CA 95131

USA

Tel: (+1)(408) 441-0311

Fax: (+1)(408) 487-2600

www.atmel.com

Atmel Asia Limited

Unit 1-5 & 16, 19/F
BEA Tower, Millennium City 5
418 Kwun Tong Road

Kwun Tong, Kowloon

HONG KONG

Tel: (+852) 2245-6100

Fax: (+852) 2722-1369

Atmel Munich GmbH

Business Campus

Parking 4

D-85748 Garching b. Munich

GERMANY

Tel: (+49) 89-31970-0

Fax: (+49) 89-3194621

Atmel Japan

16F, Shin Osaki Kangyo Bldg.

1-6-4 Osaka Shinagawa-ku

Tokyo 104-0032

JAPAN

Tel: (+81) 3-6417-0300

Fax: (+81) 3-6417-0370

© 2012 Atmel Corporation. All rights reserved.

Atmel®, Atmel logo and combinations thereof, AVR® and others are registered trademarks or trademarks of Atmel Corporation or its subsidiaries. Other terms and product names may be trademarks of others.

Disclaimer: The information in this document is provided in connection with Atmel products. No license, express or implied, by estoppel or otherwise, to any intellectual property right is granted by this document or in connection with the sale of Atmel products. **EXCEPT AS SET FORTH IN THE ATMEL TERMS AND CONDITIONS OF SALES LOCATED ON THE ATMEL WEBSITE, ATMEL ASSUMES NO LIABILITY WHATSOEVER AND DISCLAIMS ANY EXPRESS, IMPLIED OR STATUTORY WARRANTY RELATING TO ITS PRODUCTS INCLUDING, BUT NOT LIMITED TO, THE IMPLIED WARRANTY OF MERCHANTABILITY, FITNESS FOR A PARTICULAR PURPOSE, OR NON-INFRINGEMENT. IN NO EVENT SHALL ATMEL BE LIABLE FOR ANY DIRECT, INDIRECT, CONSEQUENTIAL, PUNITIVE, SPECIAL OR INCIDENTAL DAMAGES (INCLUDING, WITHOUT LIMITATION, DAMAGES FOR LOSS AND PROFITS, BUSINESS INTERRUPTION, OR LOSS OF INFORMATION) ARISING OUT OF THE USE OR INABILITY TO USE THIS DOCUMENT, EVEN IF ATMEL HAS BEEN ADVISED OF THE POSSIBILITY OF SUCH DAMAGES.** Atmel makes no representations or warranties with respect to the accuracy or completeness of the contents of this document and reserves the right to make changes to specifications and product descriptions at any time without notice. Atmel does not make any commitment to update the information contained herein. Unless specifically provided otherwise, Atmel products are not suitable for, and shall not be used in, automotive applications. Atmel products are not intended, authorized, or warranted for use as components in applications intended to support or sustain life.

Looking for pricing, stock, or lifecycle information?

Click below to explore more details on WIN SOURCE:

- ⊖ [View AT32UC3A0512-CTUR on WIN SOURCE](#)
- ⊖ [Microchip Technology Information](#)

Optimize Your Supply Chain with WIN SOURCE Solutions

- ✓ Global Sourcing Solution
- ✓ Obsolete Management
- ✓ Cost Control Management
- ✓ Shortage Management
- ✓ Alternative Solution
- ✓ Excess Inventory Management