

1. General description

PTN36043 is a very small, low power 2 differential channel 2 to 1 active multiplex/demultiplexer switch with integrated SuperSpeed USB 3.1 Gen 1 (also known as USB 3.0) redriver IC that can switch two differential signals to one of two locations. The active switch has optimized performance with minimized crosstalk, as required by the high-speed serial interface for USB Type-C connector. PTN36043 allows expansion of existing high-speed ports for very low power consumption.

With integrated USB 3.1 Gen 1 redriver, signal quality is enhanced by performing receive equalization on the deteriorated input signal followed by transmit de-emphasis maximizing system link performance. With its superior differential signal conditioning and enhancement capability, the device delivers significant flexibility and performance scaling for various systems with different PCB characteristics and cable channel conditions and still benefit from optimum power consumption.

PTN36043 has built-in advanced power management capability that enables significant power savings under various different USB 3.1 Gen 1 Low-power modes (U2/U3). It can detect link electrical conditions and can dynamically activate/de-activate internal circuitry and logic. The device performs these actions without host software intervention and conserves power.

PTN36043 is powered from a 1.8 V supply and is available in a small DHX2QFN18 package (2.4 mm × 2.0 mm × 0.35 mm) with 0.4 mm pitch.

2. Features and benefits

- 2 bidirectional differential channel, 2 : 1 multiplex/demultiplexer switch, supports USB 3.1 Gen 1 specification (SuperSpeed only)
- Compliant to SuperSpeed USB 3.1 Gen 1 standard
- Pin out data flow matches USB Type-C connector pin assignments
- Two control pins for each channel to select optimized signal conditions
 - ◆ Receive equalization on each channel to recover from InterSymbol Interference (ISI) and high-frequency losses, with provision to choose equalization gain settings per channel
 - ◆ Transmit de-emphasis on each channel delivers pre-compensation suited to channel conditions
 - ◆ Output swing adjustment
- Integrated termination resistors provide impedance matching on both transmit and receive sides
- Automatic receiver termination detection
- Low active power: 203 mW/113 mA (typical) for VDD = 1.8 V

- Power-saving states:
 - ◆ 1.35 mW/0.75 mA (typical) when in U2/U3 states
 - ◆ 0.81 mW/0.45 mA (typical) when no connection detected
- Excellent differential and common return loss performance
 - ◆ 14 dB differential and 15 dB common-mode return loss for 10 MHz to 1250 MHz
- Flow-through pinout to ease PCB layout and minimize crosstalk effects
- Power supply: VDD = 1.8 V (typical)
- Compliant with JESD 78 Class II latch up test standard
- Very thin DHX2QFN18 package: 2.4 mm x 2.0 mm x 0.35 mm, 0.4 mm pitch
- ESD protection exceeds 7000 V HBM per JDS-001-2012 and 1000 V CDM per JESD22-C101
- Latch-up testing is done to JEDEC Standard JESD78 which exceeds 100 mA
- Operating temperature range: -40°C to +85°C

3. Applications

- USB 3.1 Gen 1 application for USB Type-C connectors
- Smart Phones, Tablets/Mobile Devices
- Desktop/Notebook Computers
- Docking Stations
- USB 3.1 Gen 1 Peripherals such as flat panel display, consumer/storage devices, printers or USB 3.1 Gen 1 capable hubs/repeaters

4. Ordering information

Table 1. Ordering information

Type number	Topside marking	Package		
		Name	Description	Version
PTN36043BX	43	DHX2QFN18	plastic dual in-line compatible thermal enhanced extremely thin quad flat package; no leads; 18 terminals; body 2.4 mm × 2.0 mm × 0.35 mm	SOT1442-1

4.1 Ordering options

Table 2. Ordering options

Type number	Orderable part number	Package	Packing method	Minimum order quantity	Temperature
PTN36043BX	PTN36043BXY	DHX2QFN18	REEL 13" Q1/T1 *STANDARD MARK SMD DP	10000	T _{amb} = -40 °C to +85 °C

5. Block diagram

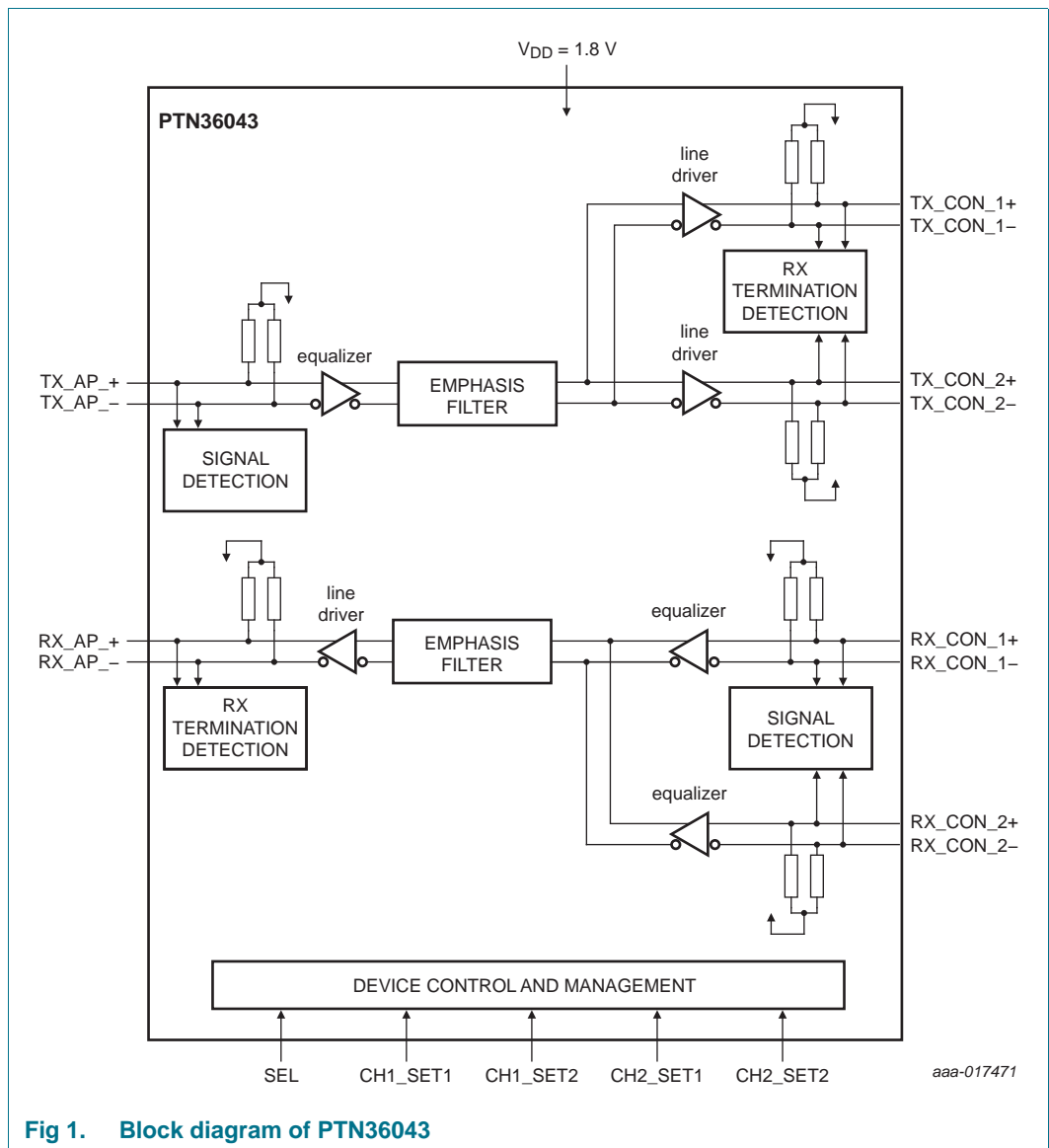

Fig 1. Block diagram of PTN36043

6. Pinning information

6.1 Pinning

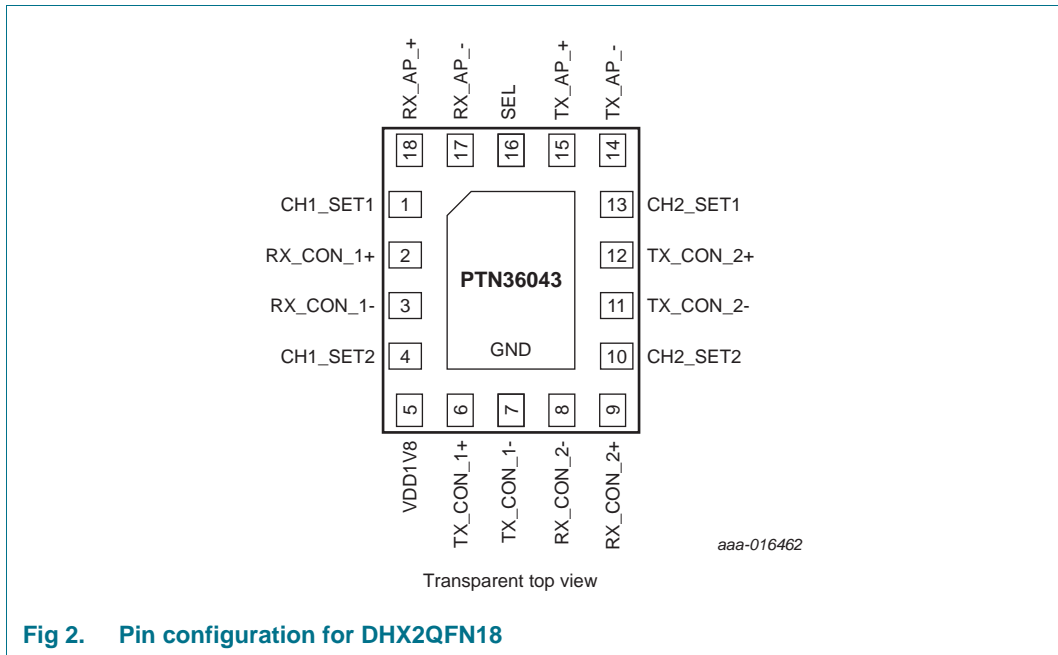

Fig 2. Pin configuration for DHX2QFN18

6.2 Pin description

Table 3. Pin description

Symbol	Pin	Type	Description
RX_AP_+	18	Output	USB 3.1 Gen 1 differential output signals of the RX path to application processor
RX_AP_-	17		
TX_AP_+	15	Input	USB 3.1 Gen 1 differential input signals of the TX path from application processor
TX_AP_-	14		
TX_CON_1+	6	Output	USB 3.1 Gen 1 differential output signals of the TX path to connector side port 1
TX_CON_1-	7		
RX_CON_1+	2	Input	USB 3.1 Gen 1 differential input signals of the RX path from connector side port 1
RX_CON_1-	3		
TX_CON_2+	12	Output	USB 3.1 Gen 1 differential output signals of the TX path to connector side port 2
TX_CON_2-	11		
RX_CON_2+	9	Input	USB 3.1 Gen 1 differential input signals of the RX path from connector side port 2
RX_CON_2-	8		

Table 3. Pin description ...continued

Symbol	Pin	Type	Description
SEL	16	input	Output selection control When SEL=0, RX_AP_±/TX_AP_± are connected to RX_CON_2±/TX_CON_2±, and RX_CON_1±/TX_CON_1± are connected to VDD thru low ohmic resistor (50 Ω). When SEL=1, RX_AP_±/TX_AP_± are connected to RX_CON_1±/TX_CON_1±, and RX_CON_2±/TX_CON_2± are connected to VDD thru low ohmic resistor (50 Ω).
CH1_SET1	1	Ternary input	OS/DE/EQ control pins for channel facing the application processor side
CH1_SET2	4		
CH2_SET1	13	Ternary input	OS/DE/EQ control pins for channel facing the connector side
CH2_SET2	10		
VDD1V8	5	Power	Power supply (1.8 V typical)
GND	Center Pad	Power	Ground. Center pad must be connected to GND plane for both electrical grounding and thermal relief purposes.

7. Functional description

Refer to [Figure 1 “Block diagram of PTN36043”](#).

PTN36043 is a high speed 2 to 1 active switch with integrated SuperSpeed USB 3.1 Gen 1 redriver meant to be used for signal integrity enhancement on various platforms - smart phone, tablet, notebook, hub, A/V display and peripheral devices, for example. With its high fidelity differential signal conditioning capability and wide configurability, this device is flexible and versatile enough for use under a variety of system environments.

The following sections describe the individual block functions and capabilities of the device in more detail.

7.1 Receive equalization, transmitter de-emphasis and output swing level controls

On the high-speed signal path, the device performs receive equalization (EQ) and transmitter de-emphasis (DE) and output swing control (OS). In addition, the device provides flat frequency gain by boosting output signal. Both flat and frequency selective gains prepare the system to cover up to losses further down the link.

[Table 4](#) lists DE/OS/EQ configuration options of the channel toward application processor side.

Table 4. Application Processor side DE/OS/EQ configuration options

CH1_SET1	CH1_SET2	RX_AP_± De-emphasis	RX_AP_± Output Swing	TX_AP_± Equalizer
LOW	LOW	-3.9 dB	1100 mV	3.0 dB
	OPEN	-3.5 dB	900 mV	3.0 dB
	HIGH	0 dB	1100 mV	3.0 dB
OPEN	LOW	0 dB	900 mV	3.0 dB
	OPEN	-3.9 dB	1100 mV	0 dB
	HIGH	-3.5 dB	900 mV	0 dB
HIGH	LOW	0 dB	1100 mV	0 dB
	OPEN	0 dB	900 mV	0 dB
	HIGH	-5.3 dB	1100 mV	6.0 dB

[Table 5](#) lists DE/OS/EQ configuration options of the channel toward connector side.

Table 5. Connector side DE/OS/EQ configuration options

CH2_SET1	CH2_SET2	TX_CON_1± TX_CON_2± De-emphasis	TX_CON_1± TX_CON_2± Output Swing	RX_CON_1± RX_CON_2± Equalizer
LOW	LOW	-5.3 dB	1100 mV	0 dB
	OPEN	-3.9 dB	1100 mV	0 dB
	HIGH	-3.5 dB	900 mV	0 dB
OPEN	LOW	-5.1 dB	900 mV	0 dB
	OPEN	-3.9 dB	1100 mV	6.0 dB
	HIGH	-3.5 dB	900 mV	6.0 dB
HIGH	LOW	-5.3 dB	1100 mV	6.0 dB
	OPEN	-5.1 dB	900 mV	6.0 dB
	HIGH	-5.3 dB	1100 mV	9.0 dB

7.2 Device states and power management

PTN36043 has implemented an advanced power management scheme that operates in tune with USB 3.1 Gen 1 bus electrical condition. Although the device does not decode USB power management commands (related to USB 3.1 Gen 1 U1/U2/U3 transitions) exchanged between USB 3.1 Gen 1 host and peripheral/device, it relies on bus electrical conditions and SEL pin setting to decide to be in one of the following states:

- **Active state** wherein device is fully operational, USB data is transported on either port 1 or port 2 in Figure 1. In this state, USB connection exists and the Receive Termination indication remains active. But there is no need for Receive Termination detection.
- **Power-saving state** wherein either port 1 or port 2 is kept enabled. In this state, squelching, detection and/or Receive termination detection circuitry are active. Based on USB connection, there are two possibilities:
 - No USB connection.
 - A USB connection exists and the link is in USB 3.1 Gen 1 U2/U3 mode.
- **Off state** when PTN36043 is not being powered (i.e., VDD1V8 = 0 V), special steps should be done to prevent back-current issues on control pins such SEL or CH1/2_SET1/2 pins when these pins' states are not low. These pins can be controlled through two different ways.
 - pull-up/pull-down resistors - make sure these pull-up resistors' VDD is the same power source as to power PTN36043. When power to PTN36043 is off, power to these pull-up resistors will be off as well.
 - external processor's GPIO - if PTN36043 is turned off when the external processor's power stays on, processor should configure these GPIOs connected to these control pins as output low (< 0.4 V) or tri-state mode (configure GPIOs as input mode). This will make sure no current will be flowing into PTN36043 through these control pins.

7.3 SEL input pin

PTN36043 is designed with 1:2 high speed de-multiplexer configuration. TX_AP_± and RX_AP_± can be connected to either TX_CON_1± and RX_CON_1±, or TX_CON_2± and RX_CON_2± by changing the SEL input state.

Table 6. SEL input setting

SEL	Function
0	TX_CON_2± and RX_CON_2± are connected to TX_AP_± and RX_AP_± TX_CON_1± and RX_CON_1± are connected to VDD thru low ohmic resistor (50 Ω).
1	TX_CON_1± and RX_CON_1± are connected to TX_AP_± and RX_AP_± TX_CON_2± and RX_CON_2± are connected to VDD thru low ohmic resistor (50 Ω).

8. Application guideline for Control of CHx_SETx and SEL input pins

PTN36043 implements ternary control IO logic on CHx_SETx and SEL control pins to detect HIGH (connected to VDD), LOW (connected to GND) or left unconnected condition (OPEN).

For all control pins except SEL, all 3 pin conditions are applicable. If the SEL pin is left unconnected (OPEN), the internal logic treats it as LOW.

To minimize the current consumption of IO circuitry on SEL pin, it is recommended this pin be driven from 1.8 V capable push-pull IO. If 1.8 V push-pull IO is not available in the application, the SEL pin can be driven from an open drain grounded NMOS GPIO with external pull-up resistor to the 1.8 V supply of PTN36043. The recommended value of the external pull-up resistor is 30 kΩ.

9. Limiting values

Table 7. Limiting values

In accordance with the Absolute Maximum Rating System (IEC 60134).

Symbol	Parameter	Conditions	Min	Max	Unit
$V_{DD(1V8)}$	supply voltage (1.8 V)		[1] -0.3	+2.2	V
V_I	input voltage		[1] -0.3	+2.2	V
T_{stg}	storage temperature		-65	+150	°C
V_{ESD}	electrostatic discharge voltage	HBM	[2] -	7000	V
		CDM	[3] -	1000	V

[1] All voltage values (except differential voltages) are with respect to network ground terminal.

[2] Human Body Model: ANSI/EOS/ESD-S5.1-1994, standard for ESD sensitivity testing, Human Body Model - Component level; Electrostatic Discharge Association, Rome, NY, USA.

[3] Charged Device Model: ANSI/EOS/ESD-S5.3-1-1999, standard for ESD sensitivity testing, Charged Device Model - Component level; Electrostatic Discharge Association, Rome, NY, USA.

10. Recommended operating conditions

Table 8. Operating conditions

Symbol	Parameter	Conditions	Min	Typ	Max	Unit
$V_{DD(1V8)}$	supply voltage (1.8 V)	1.8 V supply option	1.7	1.8	1.9	V
V_I	input voltage	CMOS inputs	-0.3	$V_{DD(1V8)}$	+2.2	V
		differential pairs	-0.3	-	+2.2	V
T_{amb}	ambient temperature	operating in free air	-40	-	+85	°C

11. Characteristics

11.1 Device characteristics

Table 9. Device characteristics

Symbol	Parameter	Conditions	Min	Typ	Max	Unit
t_{startup}	start-up time	between supply voltage within operating range (90 % of V_{DD}) until automatic receiver termination detection	-	-	6	ms
t_{rcfg1}	setting reconfiguration time	any configuration pin change (from one setting to another setting) to specified operating characteristics; device is supplied with valid supply voltage	-	-	3	ms
t_{rcfg2}	port reconfiguration time	Switching from one port to the other port (i.e., Port 1 to Port 2 or vice versa) until automatic receiver detection; device is supplied with valid supply voltage	-	-	7	ms
$t_{\text{PD(dif)}}$	differential propagation delay	between 50 % level at input and output; see Figure 3	-	-	0.5	ns
t_{idle}	idle time	default wait time to wait before getting into Power-saving state	-	300	400	ms
$t_{\text{d(pwrsave-act)}}$	delay time from power-save to active	time for exiting from Power-saving state and get into Active state; see Figure 5	-	-	115	μs
$t_{\text{d(act-idle)}}$	delay time from active to idle	reaction time for squelch detection circuit; see Figure 4	-	9	14	ns
$t_{\text{d(idle-act)}}$	delay time from idle to active	reaction time for squelch detection circuit; see Figure 4	-	5	11	ns
DDNEXT	Differential near-end crosstalk between TX and RX signal pairs within the same port	$f < 2.5 \text{ GHz}$	-	-50	-	dB
$R_{\text{th(j-a)}}$	thermal resistance from junction to ambient	JEDEC still air test environment; value is based on simulation under JEDEC still air test environment with 2S2P(4L) JEDEC PCB	-	96	-	$^{\circ}\text{C/W}$
Ψ_{jt}	junction to top of case thermal characterization parameter	to case top; at ambient temperature of 85 $^{\circ}\text{C}$; value is based on simulation under JEDEC still air test environment with 2S2P(4L) JEDEC PCB	-	1.0	-	$^{\circ}\text{C/W}$
I_{DD}	supply current	Active state				
		OS = 1100 mV/DE = -3.9 dB for both AP side and CON side	-	113	-	mA
		OS = 900 mV/DE = -3.5 dB for AP side, OS = 1100 mV/DE = -3.9 dB for CON side	-	108	-	mA
		OS = 900 mV/DE = 0 dB for AP side, OS = 1100 mV/DE = -3.9 dB for CON side	-	103	-	mA
		U2/U3 Power-saving state	-	0.75	-	mA
		no USB connection state	-	0.45	-	mA

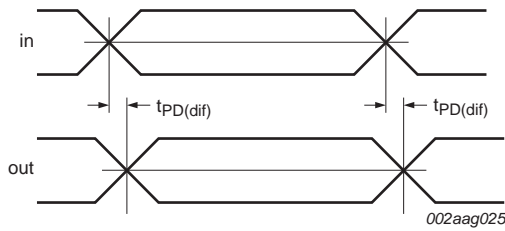

Fig 3. Propagation delay

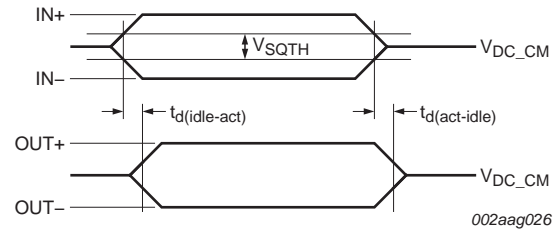

Fig 4. LFPS electrical idle transitions in U0/U1 modes

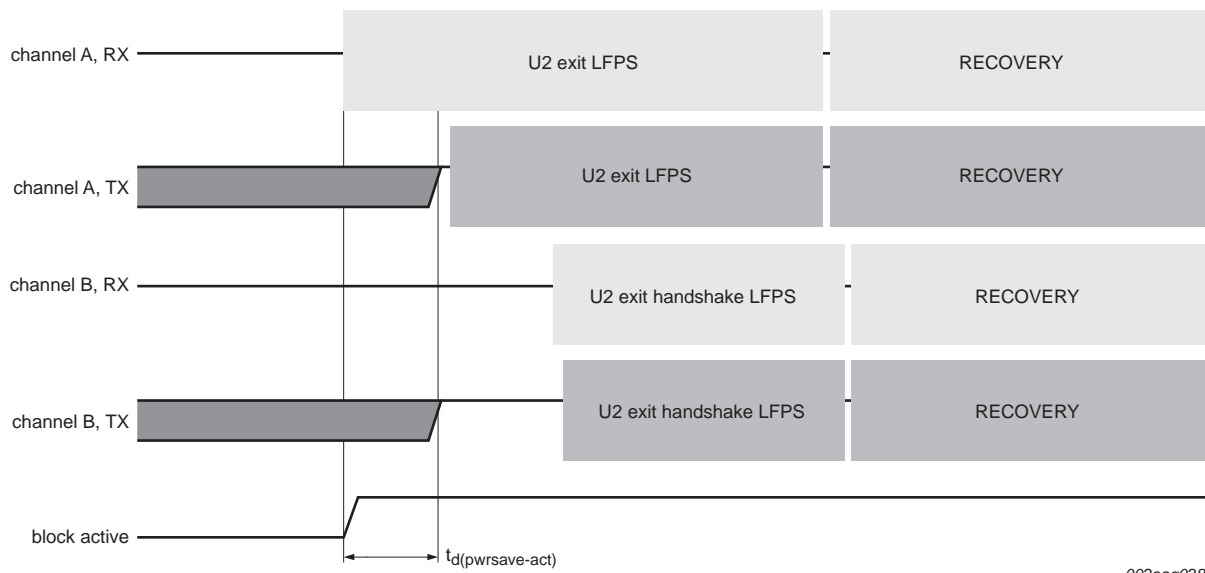

Fig 5. U2/U3 exit behavior

11.2 Receiver AC/DC characteristics

Table 10. Receiver AC/DC characteristics

Symbol	Parameter	Conditions	Min	Typ	Max	Unit
Z_{RX_DC}	receiver DC common-mode impedance		18	-	30	Ω
$Z_{RX_DIFF_DC}$	DC differential impedance	RX pair	72	-	120	Ω
$Z_{RX_HIGH_IMP}$	common-mode input impedance	DC common-mode input impedance when output of redriver is not terminated	25	-	-	$k\Omega$
$V_{RX(diff)(p-p)}$	peak-to-peak differential receiver voltage		100	-	1200	mV
$V_{RX_DC_CM}$	RX DC common mode voltage		-	1.8	-	V
$V_{RX_CM_AC_P}$	RX AC common-mode voltage	peak	-	-	150	mV
$V_{th(i)}$	signal detector input threshold voltage	differential peak-to-peak value	75	-	150	mV
$RL_{DD11,RX}$	RX differential mode return loss	10 MHz to 1250 MHz	12	14	-	dB
		1250 MHz to 2500 MHz	7	8.5	-	dB
		2500 MHz to 3000 MHz	6	7.5	-	dB
$RL_{CC11,RX}$	RX common mode return loss	10 MHz to 1250 MHz	12	15	-	dB
		1250 MHz to 2500 MHz	8	10	-	dB
		2500 MHz to 3000 MHz	7	9	-	dB

11.3 Transmitter AC/DC characteristics

Table 11. Transmitter AC/DC characteristics

Symbol	Parameter	Conditions	Min	Typ	Max	Unit
Z _{TX_DC}	transmitter DC common-mode impedance		18	-	30	Ω
Z _{TX_DIFF_DC}	DC differential impedance		72	-	120	Ω
V _{TX_DIFFp-p}	differential peak-to-peak output voltage	R _L = 100 Ω				
		OS = 900 mV	800	900	1000	mV
		OS = 1100 mV	1000	1100	1200	mV
V _{TX_DC_CM}	transmitter DC common-mode voltage		-	1.3	V _{DD(1V8)}	V
V _{TX_CM_ACpp_ACTIV}	TX AC common-mode peak-to-peak output voltage (active state)	device input fed with differential signal	-	-	100	mV
V _{TX_IDL_DIFF_ACpp}	electrical idle differential peak-to-peak output voltage	when link is in electrical idle	-	-	10	mV
t _{W(deemp)TX}	transmitter de-emphasis pulse width		160	180	200	ps
V _{TX_RCV_DETECT}	voltage change allowed during receiver detection	positive voltage swing to sense the receiver termination detection	-	0.5 × V _{TX_DIFFp-p}	600	mV
R _{TX_RCV_DETECT}	TX receiver termination detect charging resistance	output resistor of the transmitter when it does RX detection	-	3.1	-	kΩ
t _{r(tx)}	transmit rise time	measured using 20 % and 80 % levels; see Figure 6	40	55	75	ps
t _{f(tx)}	transmit fall time	measured using 20 % and 80 % levels; see Figure 6	40	55	75	ps
t _{(r-f)tx}	difference between transmit rise and fall time	measured using 20 % and 80 % levels	-	-	20	ps
RL _{DD11,TX}	TX differential mode return loss	10 MHz to 1250 MHz	12	13.5	-	dB
		1250 MHz to 2500 MHz	6.5	8	-	dB
		2500 MHz to 3000 MHz	5	6.5	-	dB
RL _{CC11,TX}	TX common mode return loss	10 MHz to 1250 MHz	12	14	-	dB
		1250 MHz to 2500 MHz	8	10	-	dB
		2500 MHz to 3000 MHz	9	10	-	dB

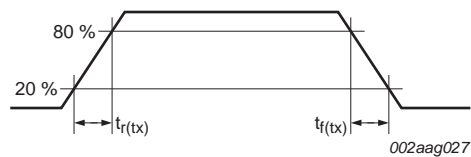

Fig 6. Output rise and fall times

11.4 Ternary control inputs

Table 12. Ternary control inputs CHx_SETx characteristics^[1]

Symbol	Parameter	Conditions	Min	Typ	Max	Unit
V _{IH}	HIGH-level input voltage	Trigger level of the Schmitt Trigger buffer when input is going from LOW to HIGH	$0.70 \times V_{DD}$	V _{DD}	V _{DD} + 0.3	V
V _{IL}	LOW-level input voltage	Trigger level of the Schmitt Trigger buffer when input is going from HIGH to LOW	-0.3	0	$0.30 \times V_{DD}$	V
R _{pu(ext)}	external pull-up resistor	connected between VDD1V8 and setting pin; for detection of HIGH condition	0	-	30	k Ω
R _{pd(ext)}	external pull-down resistor	connected between setting pin and GND; for detection of LOW condition	0	-	30	k Ω
Z _{ext(OPEN)}	external impedance	for detection of OPEN condition	250	-	-	k Ω
I _{IL}	LOW-level input current	setting pin is driven LOW by external GPIO	-45	-	-	μ A
I _{IH}	HIGH-level input current	setting pin is driven HIGH (to 1.8 V) by external GPIO	-	-	+45	μ A
I _{Lext(OPEN)}	external leakage current	of external GPIO; for reliable detection of OPEN condition	-6	-	+6	μ A
C _{L(ext)}	external load capacitance	on setting pin; for reliable detection of OPEN condition	-	-	150	pF
R _{pu(int)}	internal pull-up resistance	for detection of Ternary setting	-	50	-	k Ω
R _{pd(int)}	internal pull-down resistance	for detection of Ternary setting	-	50	-	k Ω

[1] See [Section 8](#) for application guidelines for the Ternary control pins.

Table 13. Ternary control input SEL characteristics^[1]

Symbol	Parameter	Conditions	Min	Typ	Max	Unit
V _{IH}	HIGH-level input voltage	Trigger level of the Schmitt Trigger buffer when input is going from LOW to HIGH	$0.70 \times V_{DD}$	V _{DD}	V _{DD} + 0.3	V
V _{IL}	LOW-level input voltage	Trigger level of the Schmitt Trigger buffer when input is going from HIGH to LOW	-0.3	0	$0.30 \times V_{DD}$	V
R _{pu(ext)}	external pull-up resistor	connected between VDD1V8 and setting pin; for detection of HIGH condition	0	-	30	k Ω
R _{pd(ext)}	external pull-down resistor	connected between setting pin and GND; for detection of LOW condition	0	-	30	k Ω
Z _{ext(OPEN)}	external impedance	for detection of OPEN condition and will be interpreted as LOW condition	250	-	-	k Ω
I _{IL}	LOW-level input current	setting pin is driven LOW by external GPIO	-45	-	-	μ A

Table 13. Ternary control input SEL characteristics^[1] ...continued

Symbol	Parameter	Conditions	Min	Typ	Max	Unit
I_{IH}	HIGH-level input current	setting pin is driven HIGH (to 1.8 V) by external GPIO	-	-	+45	μA
$C_{L(\text{ext})}$	external load capacitance	on setting pin; for reliable detection of OPEN condition	-	-	150	pF
$R_{pu(\text{int})}$	internal pull-up resistance	for detection of Ternary setting	-	50	-	$\text{k}\Omega$
$R_{pd(\text{int})}$	internal pull-down resistance	for detection of Ternary setting	-	50	-	$\text{k}\Omega$

[1] See [Section 8](#) for application guidelines for the Ternary control pins.

12. Package outline

DHX2QFN18: plastic dual in-line compatible thermal enhanced super-thin quad flat package; no leads; 18 terminals; body 2.4 x 2.0 x 0.35 mm

SOT1442-1

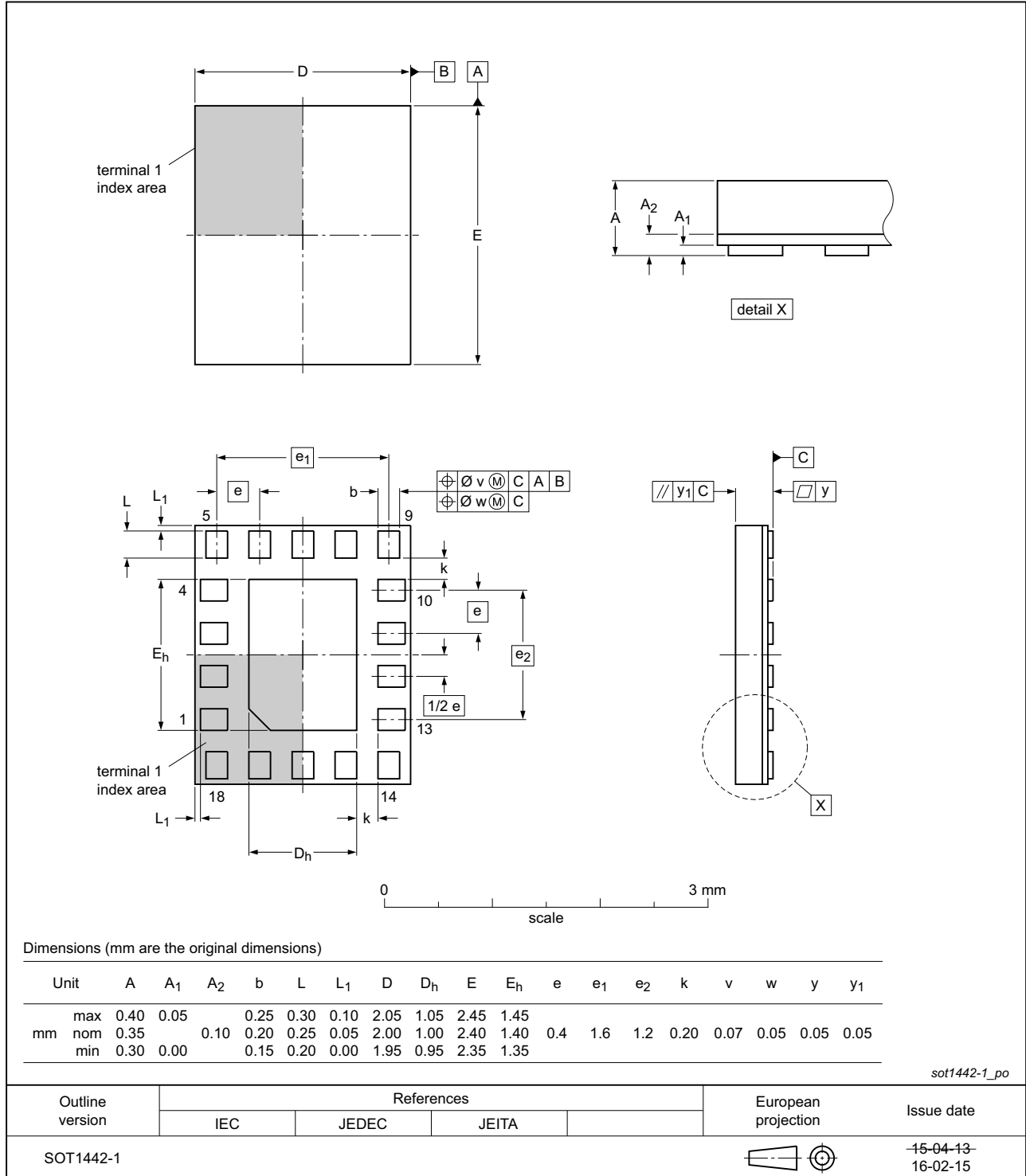

Fig 7. Package outline SOT1442-1 (DHX2QFN18)

13. Packing information

13.1 SOT1442-1 (DHXQFN18); Reel dry pack, SMD, 13" Q1/T1 standard product orientation; Orderable part number ending ,518 or Y; Ordering code (12NC) ending 518

13.1.1 Packing method

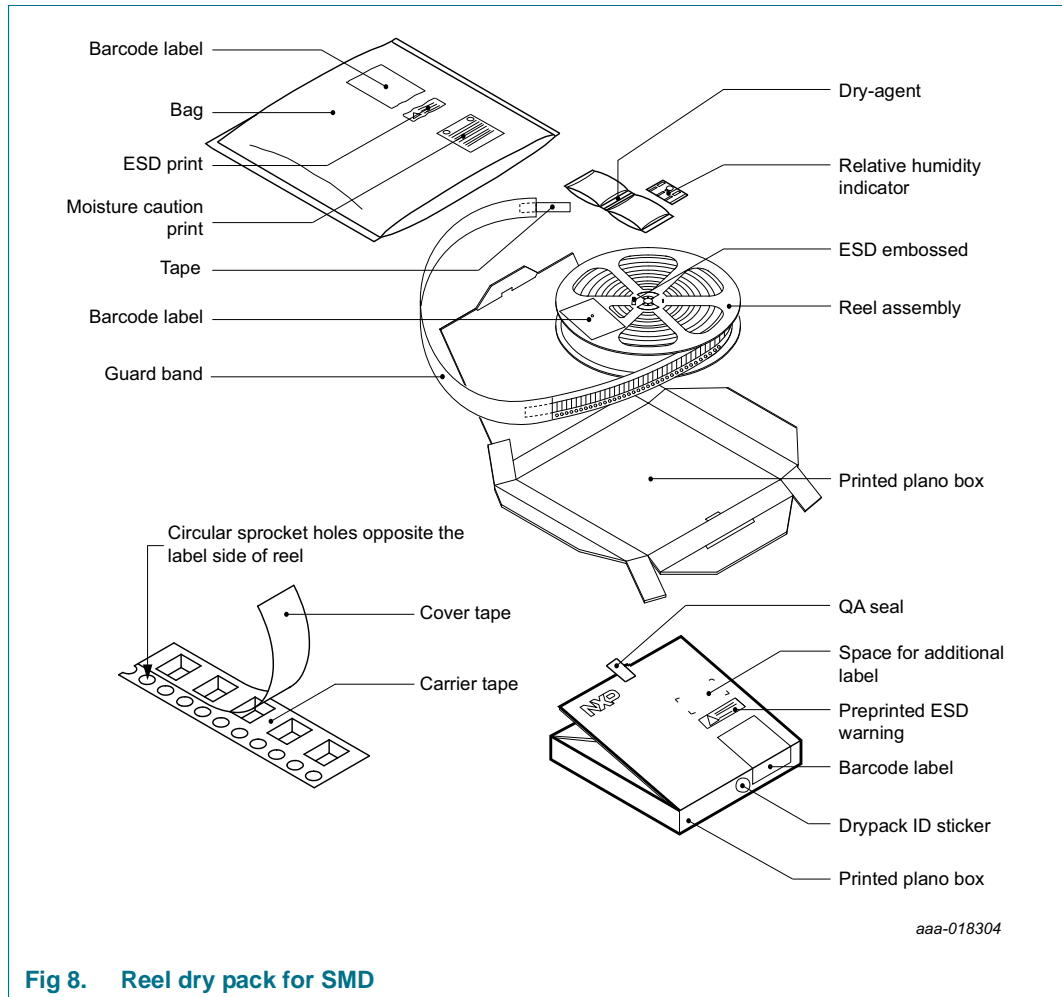

Table 14. Dimensions and quantities

Reel dimensions d × w (mm) [1]	SPQ/PQ (pcs) [2]	Reels per box	Outer box dimensions l × w × h (mm)
330 × 8	10000	1	342 × 338 × 39

[1] d = reel diameter; w = tape width.

[2] Packing quantity dependent on specific product type.

View ordering and availability details at [NXP order portal](#), or contact your local NXP representative.

13.1.1.1 Product orientation

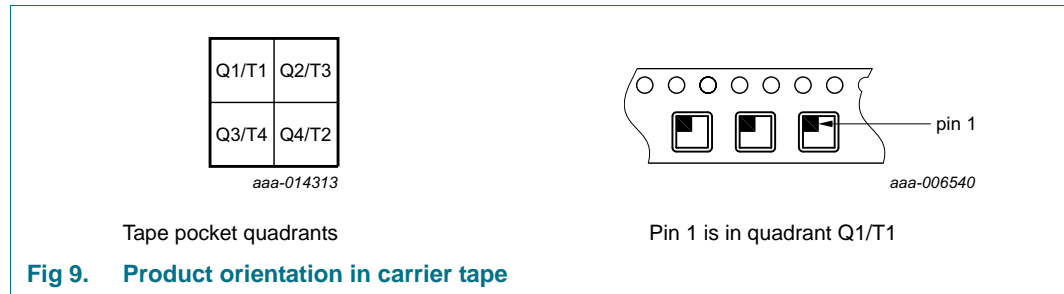

Fig 9. Product orientation in carrier tape

13.1.1.2 Carrier tape dimensions

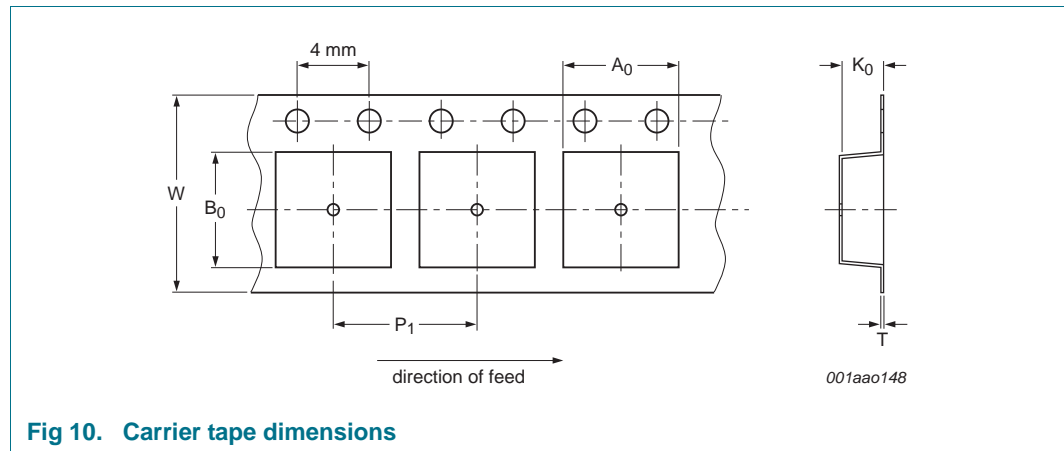

Fig 10. Carrier tape dimensions

Table 15. Carrier tape dimensions

In accordance with IEC 60286-3.

A ₀ (mm)	B ₀ (mm)	K ₀ (mm)	T (mm)	P ₁ (mm)	W (mm)
2.25 ± 0.1	2.65 ± 0.1	0.53 ± 0.05	0.25 ± 0.03	4.0 ± 0.1	8.0 + 0.3 / - 0.1

13.1.1.3 Reel dimensions

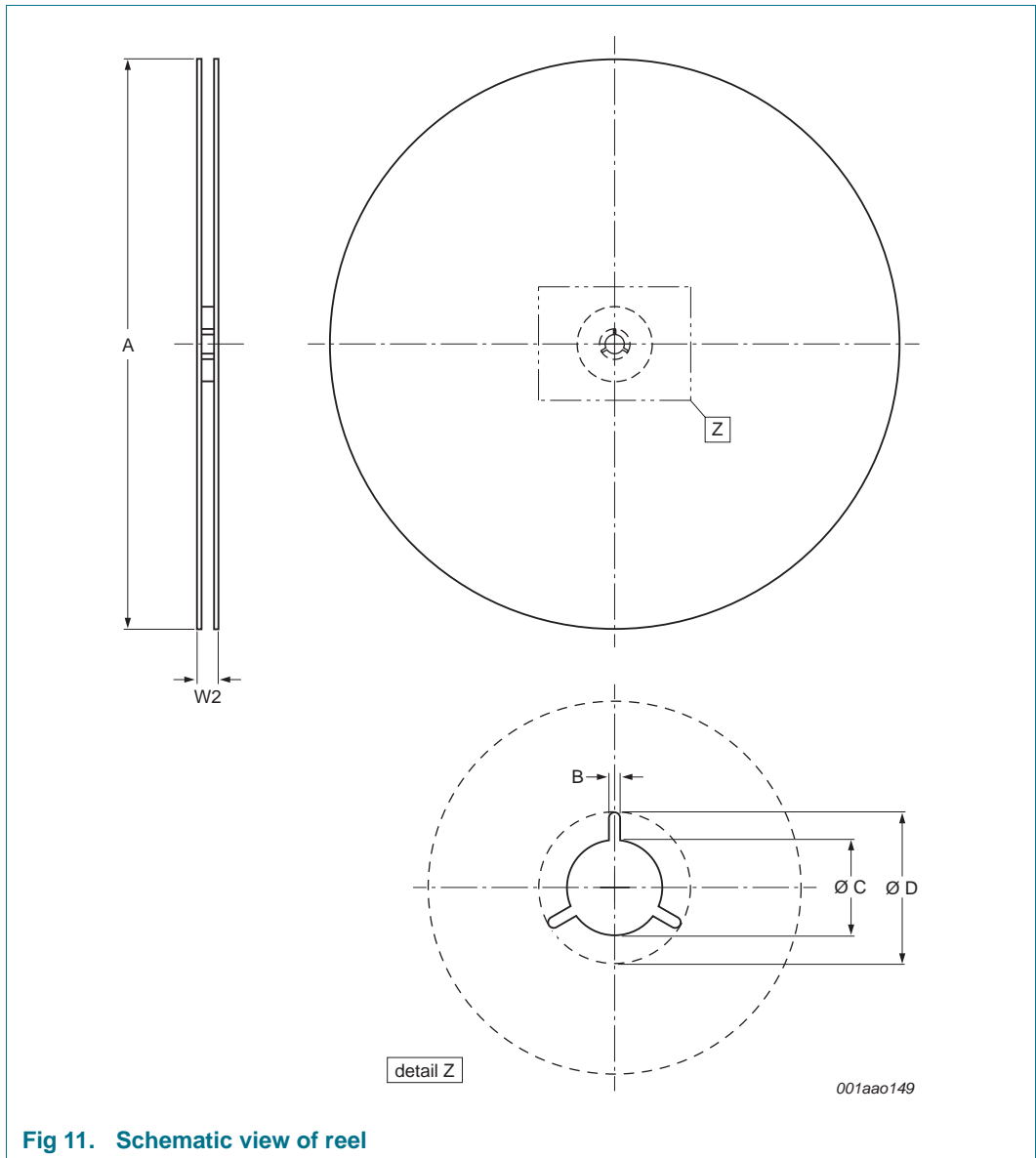

Fig 11. Schematic view of reel

Table 16. Reel dimensions
In accordance with IEC 60286-3.

A [nom] (mm)	W2 [max] (mm)	B [min] (mm)	C [min] (mm)	D [min] (mm)
330	14.4	1.5	12.8	20.2

13.1.1.4 Barcode label

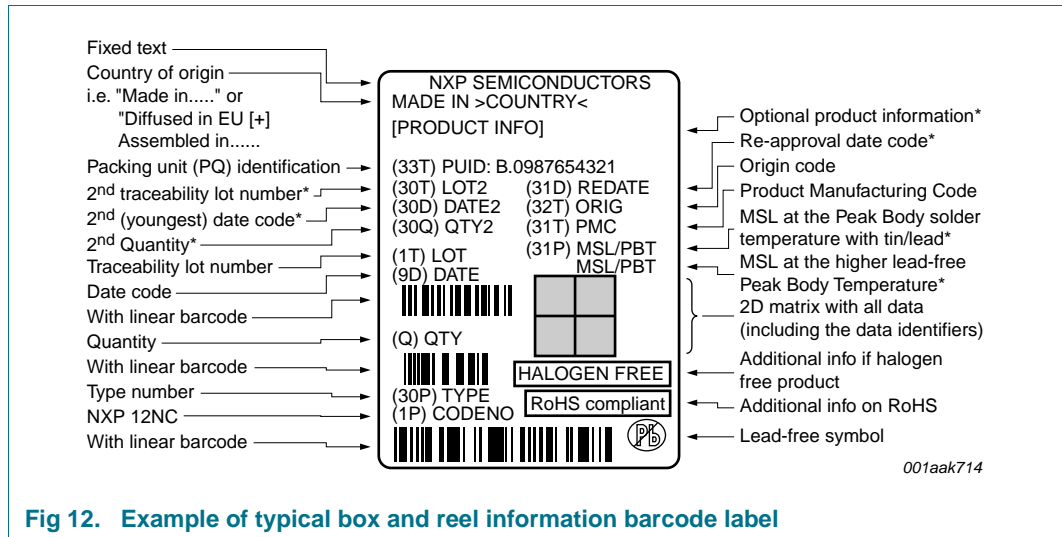

Fig 12. Example of typical box and reel information barcode label

Table 17. Barcode label dimensions

Box barcode label l × w (mm)	Reel barcode label l × w (mm)
100 × 75	100 × 75

14. Soldering of SMD packages

This text provides a very brief insight into a complex technology. A more in-depth account of soldering ICs can be found in Application Note *AN10365 "Surface mount reflow soldering description"*.

14.1 Introduction to soldering

Soldering is one of the most common methods through which packages are attached to Printed Circuit Boards (PCBs), to form electrical circuits. The soldered joint provides both the mechanical and the electrical connection. There is no single soldering method that is ideal for all IC packages. Wave soldering is often preferred when through-hole and Surface Mount Devices (SMDs) are mixed on one printed wiring board; however, it is not suitable for fine pitch SMDs. Reflow soldering is ideal for the small pitches and high densities that come with increased miniaturization.

14.2 Wave and reflow soldering

Wave soldering is a joining technology in which the joints are made by solder coming from a standing wave of liquid solder. The wave soldering process is suitable for the following:

- Through-hole components
- Leaded or leadless SMDs, which are glued to the surface of the printed circuit board

Not all SMDs can be wave soldered. Packages with solder balls, and some leadless packages which have solder lands underneath the body, cannot be wave soldered. Also, leaded SMDs with leads having a pitch smaller than ~0.6 mm cannot be wave soldered, due to an increased probability of bridging.

The reflow soldering process involves applying solder paste to a board, followed by component placement and exposure to a temperature profile. Leaded packages, packages with solder balls, and leadless packages are all reflow solderable.

Key characteristics in both wave and reflow soldering are:

- Board specifications, including the board finish, solder masks and vias
- Package footprints, including solder thieves and orientation
- The moisture sensitivity level of the packages
- Package placement
- Inspection and repair
- Lead-free soldering versus SnPb soldering

14.3 Wave soldering

Key characteristics in wave soldering are:

- Process issues, such as application of adhesive and flux, clinching of leads, board transport, the solder wave parameters, and the time during which components are exposed to the wave
- Solder bath specifications, including temperature and impurities

14.4 Reflow soldering

Key characteristics in reflow soldering are:

- Lead-free versus SnPb soldering; note that a lead-free reflow process usually leads to higher minimum peak temperatures (see [Figure 13](#)) than a SnPb process, thus reducing the process window
- Solder paste printing issues including smearing, release, and adjusting the process window for a mix of large and small components on one board
- Reflow temperature profile; this profile includes preheat, reflow (in which the board is heated to the peak temperature) and cooling down. It is imperative that the peak temperature is high enough for the solder to make reliable solder joints (a solder paste characteristic). In addition, the peak temperature must be low enough that the packages and/or boards are not damaged. The peak temperature of the package depends on package thickness and volume and is classified in accordance with [Table 18](#) and [19](#)

Table 18. SnPb eutectic process (from J-STD-020D)

Package thickness (mm)	Package reflow temperature (°C)	
	Volume (mm ³)	
	< 350	≥ 350
< 2.5	235	220
≥ 2.5	220	220

Table 19. Lead-free process (from J-STD-020D)

Package thickness (mm)	Package reflow temperature (°C)		
	Volume (mm ³)		
	< 350	350 to 2000	> 2000
< 1.6	260	260	260
1.6 to 2.5	260	250	245
> 2.5	250	245	245

Moisture sensitivity precautions, as indicated on the packing, must be respected at all times.

Studies have shown that small packages reach higher temperatures during reflow soldering, see [Figure 13](#).

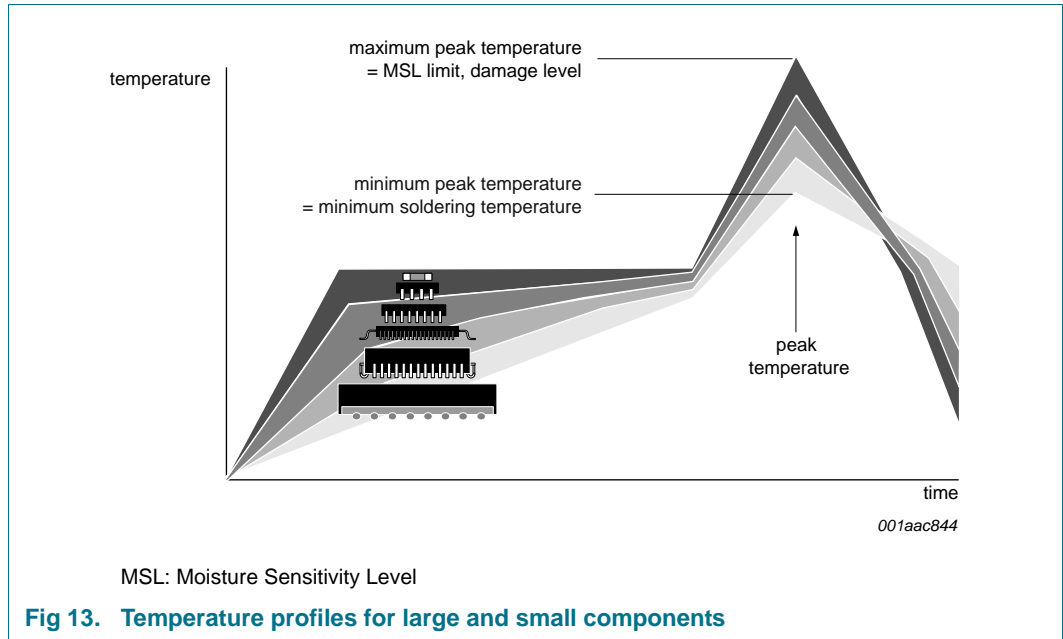

For further information on temperature profiles, refer to Application Note AN10365 “Surface mount reflow soldering description”.

15. Soldering

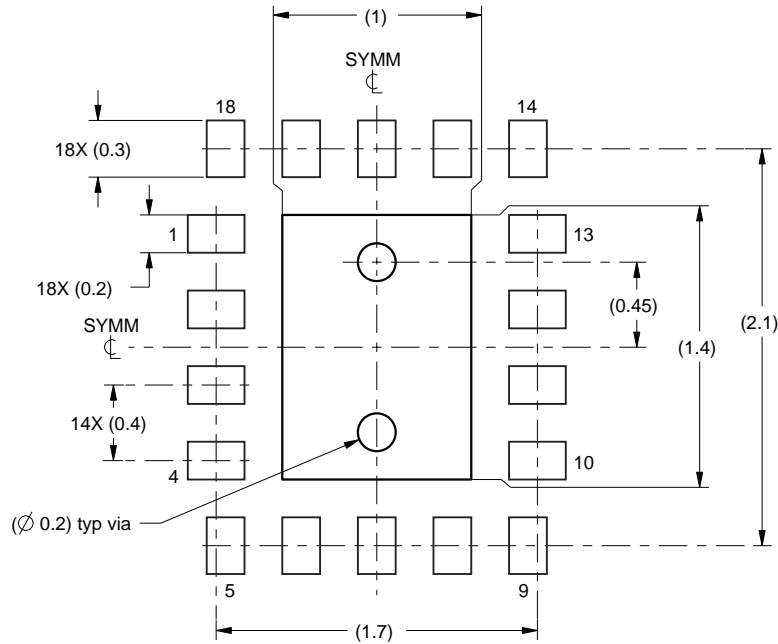

land pattern example
scale: 25x; all dimensions are in mm

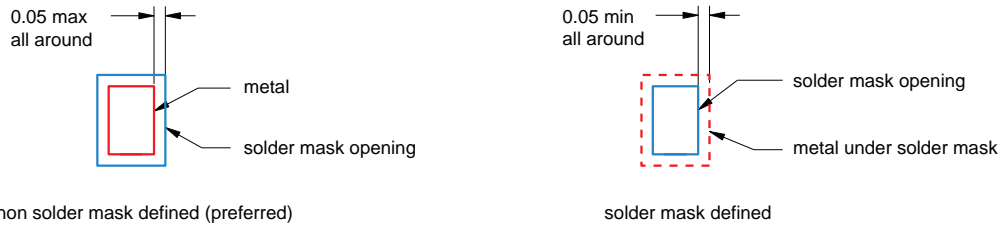

aaa-021290

Fig 14. PCB footprint for SOT1442-1 (DHX2QFN18); reflow soldering

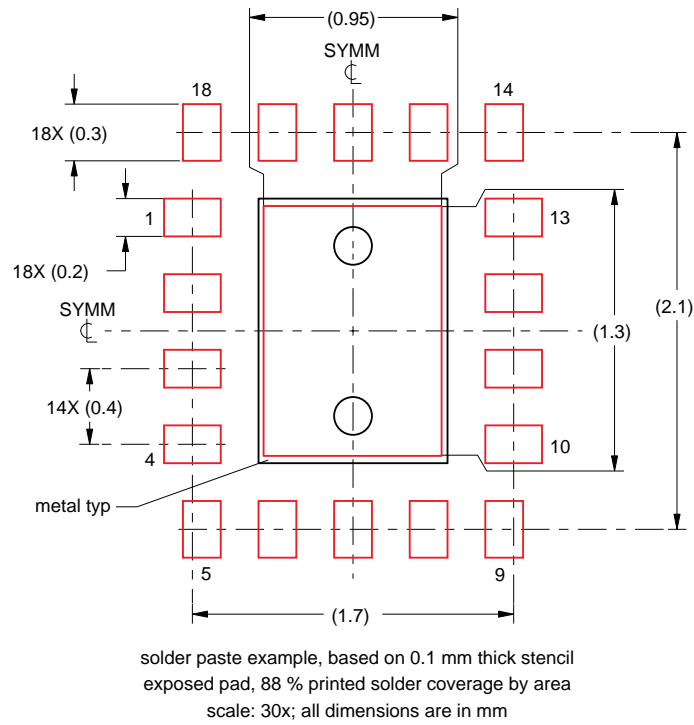

aaa-021333

Fig 15. Solder paste example

16. Abbreviations

Table 20. Abbreviations

Acronym	Description
A/V	Audio/Video device
AIO	All In One computer platform
CDM	Charged-Device Model
CMOS	Complementary Metal-Oxide Semiconductor
ESD	ElectroStatic Discharge
HBM	Human Body Model
I ² C-bus	Inter-Integrated Circuit bus
I/O	Input/Output
IC	Integrated Circuit
ISI	InterSymbol Interference
LFPS	Low Frequency Periodic Signaling
PCB	Printed-Circuit Board
RX	Receive (or Receiver)
SI	Signal Integrity
TX	Transmit (or Transmitter)
USB	Universal Serial Bus

17. Revision history

Table 21. Revision history

Document ID	Release date	Data sheet status	Change notice	Supersedes
PTN36043 v.2	20180219	Product data sheet	-	PTN36043 v.1.3
Modifications:	<ul style="list-style-type: none"> Table 3 "Pin description" and Table 6 "SEL input setting": Updated description for pin SEL from "in high impedance state for USB Type-C Safe State support" to "connected to VDD thru low ohmic resistor (50 Ω)" 			
PTN36043 v.1.3	20171117	Product data sheet	-	PTN36043 v.1.2
Modifications:	<ul style="list-style-type: none"> Table 3 "Pin description" and Table 6 "SEL input setting": Updated description for pin SEL from "connected to VDD thru low ohmic resistor (50 Ω)" to "in high impedance state for USB Type-C Safe State support" 			
PTN36043 v.1.2	20160822	Product data sheet	-	PTN36043 v.1.1
Modifications:	<ul style="list-style-type: none"> Full DS release to web; replaces short data sheet PTN36043_SDS 			
PTN36043 v.1.1	20160802	Product data sheet	-	PTN36043 v.1
Modifications:	<ul style="list-style-type: none"> Table 2 "Ordering options": Removed 500 piece minimum order quantity 			
PTN36043 v.1	20160415	Product data sheet	-	-

18. Legal information

18.1 Data sheet status

Document status ^{[1][2]}	Product status ^[3]	Definition
Objective [short] data sheet	Development	This document contains data from the objective specification for product development.
Preliminary [short] data sheet	Qualification	This document contains data from the preliminary specification.
Product [short] data sheet	Production	This document contains the product specification.

[1] Please consult the most recently issued document before initiating or completing a design.

[2] The term 'short data sheet' is explained in section "Definitions".

[3] The product status of device(s) described in this document may have changed since this document was published and may differ in case of multiple devices. The latest product status information is available on the Internet at URL <http://www.nxp.com>.

18.2 Definitions

Draft — The document is a draft version only. The content is still under internal review and subject to formal approval, which may result in modifications or additions. NXP Semiconductors does not give any representations or warranties as to the accuracy or completeness of information included herein and shall have no liability for the consequences of use of such information.

Short data sheet — A short data sheet is an extract from a full data sheet with the same product type number(s) and title. A short data sheet is intended for quick reference only and should not be relied upon to contain detailed and full information. For detailed and full information see the relevant full data sheet, which is available on request via the local NXP Semiconductors sales office. In case of any inconsistency or conflict with the short data sheet, the full data sheet shall prevail.

Product specification — The information and data provided in a Product data sheet shall define the specification of the product as agreed between NXP Semiconductors and its customer, unless NXP Semiconductors and customer have explicitly agreed otherwise in writing. In no event however, shall an agreement be valid in which the NXP Semiconductors product is deemed to offer functions and qualities beyond those described in the Product data sheet.

18.3 Disclaimers

Limited warranty and liability — Information in this document is believed to be accurate and reliable. However, NXP Semiconductors does not give any representations or warranties, expressed or implied, as to the accuracy or completeness of such information and shall have no liability for the consequences of use of such information. NXP Semiconductors takes no responsibility for the content in this document if provided by an information source outside of NXP Semiconductors.

In no event shall NXP Semiconductors be liable for any indirect, incidental, punitive, special or consequential damages (including - without limitation - lost profits, lost savings, business interruption, costs related to the removal or replacement of any products or rework charges) whether or not such damages are based on tort (including negligence), warranty, breach of contract or any other legal theory.

Notwithstanding any damages that customer might incur for any reason whatsoever, NXP Semiconductors' aggregate and cumulative liability towards customer for the products described herein shall be limited in accordance with the *Terms and conditions of commercial sale* of NXP Semiconductors.

Right to make changes — NXP Semiconductors reserves the right to make changes to information published in this document, including without limitation specifications and product descriptions, at any time and without notice. This document supersedes and replaces all information supplied prior to the publication hereof.

Suitability for use — NXP Semiconductors products are not designed, authorized or warranted to be suitable for use in life support, life-critical or safety-critical systems or equipment, nor in applications where failure or malfunction of an NXP Semiconductors product can reasonably be expected to result in personal injury, death or severe property or environmental damage. NXP Semiconductors and its suppliers accept no liability for inclusion and/or use of NXP Semiconductors products in such equipment or applications and therefore such inclusion and/or use is at the customer's own risk.

Applications — Applications that are described herein for any of these products are for illustrative purposes only. NXP Semiconductors makes no representation or warranty that such applications will be suitable for the specified use without further testing or modification.

Customers are responsible for the design and operation of their applications and products using NXP Semiconductors products, and NXP Semiconductors accepts no liability for any assistance with applications or customer product design. It is customer's sole responsibility to determine whether the NXP Semiconductors product is suitable and fit for the customer's applications and products planned, as well as for the planned application and use of customer's third party customer(s). Customers should provide appropriate design and operating safeguards to minimize the risks associated with their applications and products.

NXP Semiconductors does not accept any liability related to any default, damage, costs or problem which is based on any weakness or default in the customer's applications or products, or the application or use by customer's third party customer(s). Customer is responsible for doing all necessary testing for the customer's applications and products using NXP Semiconductors products in order to avoid a default of the applications and the products or of the application or use by customer's third party customer(s). NXP does not accept any liability in this respect.

Limiting values — Stress above one or more limiting values (as defined in the Absolute Maximum Ratings System of IEC 60134) will cause permanent damage to the device. Limiting values are stress ratings only and (proper) operation of the device at these or any other conditions above those given in the Recommended operating conditions section (if present) or the Characteristics sections of this document is not warranted. Constant or repeated exposure to limiting values will permanently and irreversibly affect the quality and reliability of the device.

Terms and conditions of commercial sale — NXP Semiconductors products are sold subject to the general terms and conditions of commercial sale, as published at <http://www.nxp.com/profile/terms>, unless otherwise agreed in a valid written individual agreement. In case an individual agreement is concluded only the terms and conditions of the respective agreement shall apply. NXP Semiconductors hereby expressly objects to applying the customer's general terms and conditions with regard to the purchase of NXP Semiconductors products by customer.

No offer to sell or license — Nothing in this document may be interpreted or construed as an offer to sell products that is open for acceptance or the grant, conveyance or implication of any license under any copyrights, patents or other industrial or intellectual property rights.

Export control — This document as well as the item(s) described herein may be subject to export control regulations. Export might require a prior authorization from competent authorities.

Non-automotive qualified products — Unless this data sheet expressly states that this specific NXP Semiconductors product is automotive qualified, the product is not suitable for automotive use. It is neither qualified nor tested in accordance with automotive testing or application requirements. NXP Semiconductors accepts no liability for inclusion and/or use of non-automotive qualified products in automotive equipment or applications.

In the event that customer uses the product for design-in and use in automotive applications to automotive specifications and standards, customer (a) shall use the product without NXP Semiconductors' warranty of the product for such automotive applications, use and specifications, and (b) whenever customer uses the product for automotive applications beyond

NXP Semiconductors' specifications such use shall be solely at customer's own risk, and (c) customer fully indemnifies NXP Semiconductors for any liability, damages or failed product claims resulting from customer design and use of the product for automotive applications beyond NXP Semiconductors' standard warranty and NXP Semiconductors' product specifications.

Translations — A non-English (translated) version of a document is for reference only. The English version shall prevail in case of any discrepancy between the translated and English versions.

18.4 Trademarks

Notice: All referenced brands, product names, service names and trademarks are the property of their respective owners.

19. Contact information

For more information, please visit: <http://www.nxp.com>

For sales office addresses, please send an email to: salesaddresses@nxp.com

20. Contents

1	General description	1	18.2	Definitions	27
2	Features and benefits	1	18.3	Disclaimers	27
3	Applications	2	18.4	Trademarks	28
4	Ordering information	2	19	Contact information	28
4.1	Ordering options	2	20	Contents	29
5	Block diagram	3			
6	Pinning information	4			
6.1	Pinning	4			
6.2	Pin description	4			
7	Functional description	6			
7.1	Receive equalization, transmitter de-emphasis and output swing level controls	6			
7.2	Device states and power management	7			
7.3	SEL input pin	8			
8	Application guideline for Control of CHx_SETx and SEL input pins	8			
9	Limiting values	9			
10	Recommended operating conditions	9			
11	Characteristics	10			
11.1	Device characteristics	10			
11.2	Receiver AC/DC characteristics	12			
11.3	Transmitter AC/DC characteristics	13			
11.4	Ternary control inputs	14			
12	Package outline	16			
13	Packing information	17			
13.1	SOT1442-1 (DHXQFN18); Reel dry pack, SMD, 13" Q1/T1 standard product orientation; Orderable part number ending ,518 or Y; Ordering code (12NC) ending 518	17			
13.1.1	Packing method	17			
13.1.1.1	Product orientation	18			
13.1.1.2	Carrier tape dimensions	18			
13.1.1.3	Reel dimensions	19			
13.1.1.4	Barcode label	20			
14	Soldering of SMD packages	21			
14.1	Introduction to soldering	21			
14.2	Wave and reflow soldering	21			
14.3	Wave soldering	21			
14.4	Reflow soldering	22			
15	Soldering	24			
16	Abbreviations	26			
17	Revision history	26			
18	Legal information	27			
18.1	Data sheet status	27			

Please be aware that important notices concerning this document and the product(s) described herein, have been included in section 'Legal information'.

© NXP Semiconductors N.V. 2018.

All rights reserved.

For more information, please visit: <http://www.nxp.com>

For sales office addresses, please send an email to: salesaddresses@nxp.com

Date of release: 19 February 2018

Document identifier: PTN36043

Looking for pricing, stock, or lifecycle information?

Click below to explore more details on WIN SOURCE:

 [View PTN36043BXY on WIN SOURCE](#)

 [NXP / Nexperia Information](#)

Optimize Your Supply Chain with WIN SOURCE Solutions

-  Global Sourcing Solution
-  Obsolete Management
-  Cost Control Management
-  Shortage Management
-  Alternative Solution
-  Excess Inventory Management