



**2.5V/3.3V/5V 1:5 LVPECL/PECL/
ECL/HSTL 2GHz CLOCK DRIVER
WITH 2:1 DIFFERENTIAL INPUT MUX**

**Precision Edge®
SY100EP14U**

FEATURES

- **Guaranteed AC parameters over temp/voltage:**
 - > 2GHz f_{MAX}
 - < 25ps within-device skew
 - < 275ps tr/TF time
 - < 525ps prop delay
- **2:1 Differential MUX input**
- **Flexible supply voltage: 2.5V/3.3V/5V**
- **Wide operating temperature range: -40°C to +85°C**
- **V_{BB} reference for single-ended or AC-coupled PECL inputs**
- **100K ECL compatible outputs**
- **Inputs accept PECL/LVPECL/ECL/HSTL logic**
- **75k Ω internal input pull-down resistors**
- **Available in a 20-Pin TSSOP package**



ECL Pro™

DESCRIPTION

The SY100EP14U is a high-speed, 2GHz differential PECL/ECL 1:5 fanout buffer optimized for ultra-low skew applications. Within device skew is guaranteed to be less than 25ps over temperature and supply voltage. The wide supply voltage operation allows this fanout buffer to operate in 2.5V, 3.3V, and 5V systems. A V_{BB} reference is included for single-supply or AC-coupled PECL/ECL input applications, thus eliminating resistor networks. When interfacing to a single-ended or AC-coupled PECL/ECL input signal, connect the V_{BB} pin to the unused /CLK pin, and bypass the pin to V_{CC} through a 0.01 μ F capacitor.

The SY100EP14U features a 2:1 input MUX, making it an ideal solution for redundant clock switchover applications. If only one input pair is used, the other pair may be left floating. In addition, this device includes a synchronous enable pin that forces the outputs into a fixed logic state. Enable or disable state is initiated only after the outputs are in a LOW state, thus eliminating the possibility of a “runt” clock pulse.

The SY100EP14U I/O are fully differential and 100K ECL compatible. Differential 10K ECL logic can interface directly into the SY100EP14U inputs.

The SY100EP14U is part of Micrel’s high-speed clock synchronization family. For applications that require a different I/O combination, consult the Micrel website at www.micrel.com, and choose from a comprehensive product line of high-speed, low-skew fanout buffers, translators, and clock generators.

PACKAGE/ORDERING INFORMATION

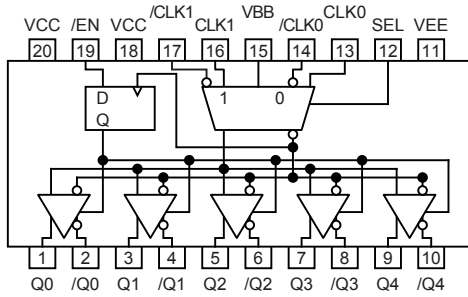

20-Pin TSSOP

Ordering Information⁽¹⁾

Part Number	Package Type	Operating Range	Package Marking
SY100EP14UK4C	K4-20-1	Commercial	XEP14U
SY100EP14UK4CTR ⁽²⁾	K4-20-1	Commercial	XEP14U
SY100EP14UK4I	K4-20-1	Industrial	XEP14U
SY100EP14UK4ITR ⁽²⁾	K4-20-1	Industrial	XEP14U
SY100EP14UK4G ⁽³⁾	K4-20-1	Industrial	XEP14U with Pb-Free bar line indicator
SY100EP14UK4GTR ^(2, 3)	K4-20-1	Industrial	XEP14U with Pb-Free bar line indicator

Notes:

1. Contact factory for die availability. Dice are guaranteed at T_A = 25°C, DC Electricals only.
2. Tape and Reel.
3. Pb-Free package is recommended for new designs.

PIN DESCRIPTION

Pin	Function
CLK0, /CLK0 CLK1, /CLK1	PECL, LVPECL, ECL, LVECL, HSTL Clock or Data Inputs. Internal 75kΩ pull-down resistors on CLK0, CLK1, and internal 75kΩ pull-up and 75kΩ pull-down resistors or /CLK0, /CLK1. For single-ended applications, connect signal into CLK0 and/or CLK1 inputs. /CLK0, /CLK1 default condition is $V_{CC}/2$ when left floating. CLK0, CLK1 default condition is LOW when left floating.
Q0 to Q4 /Q0 to /Q4	LVPECL, PECL, ECL Differential Outputs: Terminate with 50Ω to $V_{CC}-2V$. For single-ended applications, terminate the unused output with 50Ω to $V_{CC}-2V$
/EN	LVPECL, PECL, ECL compatible synchronous enable: When /EN goes HIGH, the Q_{OUT} will go LOW and / Q_{OUT} will go HIGH on the next LOW input clock transition. Includes a 75kΩ pull-down. Default state is LOW when left floating. The internal latch is clocked on the falling edge of the input clock (CLK0, CLK1)
SEL	LVPECL, PECL, ECL compatible 2:1 Mux input signal select: When SEL is LOW, CLK0 input pair is selected. When SEL is HIGH, CLK1 input pair is selected. Includes a 75kΩ pull-down. Default state is LOW and CLK0 is selected.
V_{BB}	Output Reference Voltage: Equal to $V_{CC}-1.7V$ (approx.), and used for single-ended input signals or AC-coupled applications. For single-ended PECL, LVPECL applications, bypass with a 0.01μF to V_{CC} . For single-ended LVTTTL inputs, bypass to GND. Max. sink/source current is 0.5mA.
V_{CC}	Positive Power Supply: Bypass with 0.1μF//0.01μF low ESR capacitors.
V_{EE}	Negative Power Supply: LVPECL, PECL applications, connect to GND.

TRUTH TABLE⁽¹⁾

CLK0	CLK1	CLK_SEL	/EN	Q
L	X	L	L	L
H	X	L	L	H
X	L	H	L	L
X	H	H	L	H
X	X	X	H	L*

Note 1. On next negative transition of CLK0 or CLK1.

FUNCTION TABLE

CLK_SEL	Active Input
0	CLK0, /CLK0
1	CLK1, /CLK1

ABSOLUTE MAXIMUM RATINGS⁽¹⁾

Symbol	Rating	Value	Unit
$V_{CC} - V_{EE}$	Power Supply Voltage	6.0	V
V_{IN}	Input Voltage ($V_{CC} = 0V$, V_{IN} not more negative than V_{EE}) Input Voltage ($V_{EE} = 0V$, V_{IN} not more positive than V_{CC})	-6.0 to 0 +6.0 to 0	V
I_{OUT}	Output Current -Continuous -Surge	50 100	mA
I_{BB}	V_{BB} Sink/Source Current ⁽²⁾	±0.5	mA
T_{LEAD}	Lead Temperature (soldering, 20sec.)	+260	°C
T_A	Operating Temperature Range	-40 to +85	°C
T_{store}	Storage Temperature Range	-65 to +150	°C
ESD	Mil Std. 883 Human Body Model, All Pins	>1.5k	V
θ_{JA}	Package Thermal Resistance (Junction-to-Ambient) -Still-Air (single-layer PCB) -Still-Air (multi-layer PCB) -500lfpm (multi-layer PCB)	115 75 65	°C/W
θ_{JC}	Package Thermal Resistance (Junction-to-Case)	21	°C/W

Note 1. Permanent device damage may occur if absolute maximum ratings are exceeded. This is a stress rating only and functional operation is not implied at conditions other than those detailed in the operational sections of this data sheet. Exposure to absolute maximum rating conditions for extended periods may affect device reliability.

Note 2. Due to the limited drive capability, use for inputs of same package only.

DC ELECTRICAL CHARACTERISTICS⁽¹⁾

Symbol	Parameter	$T_A = -40^\circ\text{C}$			$T_A = +25^\circ\text{C}$			$T_A = +85^\circ\text{C}$			Unit	Condition	
		Min.	Typ.	Max.	Min.	Typ.	Max.	Min.	Typ.	Max.			
V_{CC}	Power Supply Voltage										V		
	(PECL)	4.5	5.0	5.5	4.5	5.0	5.5	4.5	5.0	5.5			
	(LVPECL)	2.37	3.3	3.8	2.37	3.3	3.8	2.37	3.3	3.8			
	(ECL)	-4.5	-5.0	-5.5	-4.5	-5.0	-5.5	-4.5	-5.0	-5.5			
	(LVECL)	-3.8	-3.3	-2.37	-3.8	-3.3	-2.37	-3.8	-3.3	-2.37			
I_{CC}	Power Supply Current	—	—	75	—	68	78	—	—	82	mA		
I_{IH}	Input HIGH Current	—	—	150	—	—	150	—	—	150	µA	$V_{IN} = V_{IH}$	
I_{IL}	Input LOW Current	D	0.5	—	—	0.5	—	—	0.5	—	—	µA	$V_{IN} = V_{IL}$
		/D	-150	—	—	-150	—	—	-150	—	—	µA	$V_{IN} = V_{IL}$
C_{IN}	Input Capacitance (TSSOP)	—	—	—	—	0.75	—	—	—	—	pF		

Note 1. 100KEP circuits are designed to meet the DC specifications shown in the above table after thermal equilibrium has been established. The circuit is in a test socket or mounted on a printed circuit board and traverse airflow greater than 500lfpm is maintained.

(100KEP) LVPECL DC ELECTRICAL CHARACTERISTICS⁽¹⁾

$V_{CC} = 2.5V \pm 5\%$, $V_{EE} = 0V$

Symbol	Parameter	$T_A = -40^\circ C$			$T_A = +25^\circ C$			$T_A = +85^\circ C$			Unit	Condition
		Min.	Typ.	Max.	Min.	Typ.	Max.	Min.	Typ.	Max.		
V_{IL}	Input LOW Voltage ⁽²⁾ (Single-ended)	555	—	875	555	—	875	555	—	875	mV	
V_{IH}	Input HIGH Voltage ⁽²⁾ (Single-ended)	1335	—	1620	1335	—	1620	1335	—	1620	mV	
V_{OL}	Output LOW Voltage	555	680	805	555	680	805	555	680	805	mV	50Ω to $V_{CC}-2V$
V_{OH}	Output HIGH Voltage	1355	1480	1605	1355	1480	1605	1355	1480	1605	mV	50Ω to $V_{CC}-2V$
V_{IHCMR}	Input HIGH Voltage Common Mode Range ⁽³⁾	1.2	—	V_{CC}	1.2	—	V_{CC}	1.2	—	V_{CC}	V	

Note 1. 100KEP circuits are designed to meet the DC specifications shown in the above table after thermal equilibrium has been established. The circuit is in a test socket or mounted on a printed circuit board and traverse airflow greater than 500lfpm is maintained. Input and output varies 1:1 with V_{CC} .

Note 2. V_{BB} reference is not functional for $V_{CC} < 3.0V$. External V_{BB} equivalent is required.

Note 3. V_{IHCMR} (min) varies 1:1 with V_{EE} . V_{IHCMR} (Max) varies 1:1 with V_{CC} . The V_{IHCMR} range is referenced to the most positive side of the differential input signal.

(100KEP) LVPECL DC ELECTRICAL CHARACTERISTICS⁽¹⁾

$V_{CC} = 3.3V \pm 10\%$; $V_{EE} = 0V$

Symbol	Parameter	$T_A = -40^\circ C$			$T_A = +25^\circ C$			$T_A = +85^\circ C$			Unit	Condition
		Min.	Typ.	Max.	Min.	Typ.	Max.	Min.	Typ.	Max.		
V_{IL}	Input LOW Voltage (Single-Ended)	1355	—	1675	1355	—	1675	1355	—	1675	mV	
V_{IH}	Input HIGH Voltage (Single-Ended)	2075	—	2420	2075	—	2420	2075	—	2420	mV	
V_{OL}	Output LOW Voltage	1355	1480	1605	1355	1480	1605	1355	1480	1605	mV	50Ω to $V_{CC}-2V$
V_{OH}	Output HIGH Voltage	2155	2280	2405	2155	2280	2405	2155	2280	2405	mV	50Ω to $V_{CC}-2V$
V_{BB}	Reference Voltage ⁽²⁾	1775	1875	1975	1775	1875	1975	1775	1875	1975	mV	$V_{CC} = 3.3V$
V_{IHCMR}	Input HIGH Voltage Common Mode Range ⁽³⁾	1.2	—	V_{CC}	1.2	—	V_{CC}	1.2	—	V_{CC}	V	

Note 1. 100KEP circuits are designed to meet the DC specifications shown in the above table after thermal equilibrium has been established. The circuit is in a test socket or mounted on a printed circuit board and traverse airflow greater than 500lfpm is maintained. Input and output varies 1:1 with V_{CC} .

Note 2. Single-ended input operation is limited $V_{CC} \geq 3.0V$ in LVPECL mode. V_{BB} reference varies 1:1 with V_{CC} .

Note 3. V_{IHCMR} (min) varies 1:1 with V_{EE} . V_{IHCMR} (Max) varies 1:1 with V_{CC} . The V_{IHCMR} range is referenced to the most positive side of the differential input signal.

(100KEP) PECL DC ELECTRICAL CHARACTERISTICS⁽¹⁾ $V_{CC} = 5.0V \pm 10\%$, $V_{EE} = 0V$

Symbol	Parameter	$T_A = -40^\circ C$			$T_A = +25^\circ C$			$T_A = +85^\circ C$			Unit	Condition
		Min.	Typ.	Max.	Min.	Typ.	Max.	Min.	Typ.	Max.		
V_{IL}	Input LOW Voltage (Single-Ended)	3055	—	3375	3055	—	3375	3055	—	3375	mV	
V_{IH}	Input HIGH Voltage (Single-Ended)	3775	—	4120	3775	—	4120	3775	—	4120	mV	
V_{OL}	Output LOW Voltage	3055	3180	3305	3055	3180	3305	3055	3180	3305	mV	50Ω to $V_{CC}-2V$
V_{OH}	Output HIGH Voltage	3855	3980	4105	3855	3980	4105	3855	3980	4105	mV	50Ω to $V_{CC}-2V$
V_{BB}	Output Voltage Reference ⁽²⁾	3475	3575	3675	3475	3575	3675	3475	3575	3675	mV	$V_{CC} = +5.0V$
V_{IHCMR}	Input HIGH Voltage ⁽³⁾ Common Mode Range	2.0	—	V_{CC}	2.0	—	V_{CC}	2.0	—	V_{CC}	V	

- Note 1.** 100KEP circuits are designed to meet the DC specifications shown in the above table after thermal equilibrium has been established. The circuit is in a test socket or mounted on a printed circuit board and traverse airflow greater than 500lfpm is maintained. Input and output parameters are at $V_{CC} = 5.0V$. They vary 1:1 with V_{CC} .
- Note 2.** V_{BB} reference varies 1:1 with V_{CC} .
- Note 3.** The V_{IHCMR} range is referenced to the most positive side of the differential input signal. Single-ended input CLK pin operation is limited to $V_{CC} \geq 3.0V$ in PECL mode.

(100KEP) LVECL DC ELECTRICAL CHARACTERISTICS⁽¹⁾ $V_{EE} = -2.37V$ to $-3.8V$; $V_{CC} = 0V$

Symbol	Parameter	$T_A = -40^\circ C$			$T_A = +25^\circ C$			$T_A = +85^\circ C$			Unit	Condition
		Min.	Typ.	Max.	Min.	Typ.	Max.	Min.	Typ.	Max.		
V_{IL}	Input LOW Voltage (Single-ended)	-1945	—	-1625	-1945	—	-1625	-1945	—	-1625	mV	
V_{IH}	Input HIGH Voltage (Single-ended)	-1165	—	-880	-1165	—	-880	-1165	—	-880	mV	
V_{OL}	Output LOW Voltage	-1945	-1820	-1695	-1945	-1820	-1695	-1945	-1820	-1695	mV	50Ω to $V_{CC}-2V$
V_{OH}	Output HIGH Voltage	-1145	-1020	-0895	-1145	-1020	-0895	-1145	-1020	-0895	mV	50Ω to $V_{CC}-2V$
V_{BB}	Output Reference Voltage ⁽²⁾	-1525	-1425	-1325	-1525	-1425	-1325	-1525	-1425	-1325	mV	
V_{IHCMR}	Input HIGH Voltage Common Mode Range ⁽³⁾	$V_{EE} + 1.2$		0.0	$V_{EE} + 1.2$		0.0	$V_{EE} + 1.2$		0.0	V	

- Note 1.** 100KEP circuits are designed to meet the DC specifications shown in the above table after thermal equilibrium has been established. The circuit is in a test socket or mounted on a printed circuit board and traverse airflow greater than 500lfpm is maintained. Input and output parameters vary 1:1 with V_{CC} .
- Note 2.** Single-ended input operation is limited $V_{EE} \leq -3.0V$ in ECL/LVECL mode. V_{BB} reference varies 1:1 with V_{CC} .
- Note 3.** V_{IHCMR} (min) varies 1:1 with V_{EE} . V_{IHCMR} (max) varies 1:1 with V_{CC} . The V_{IHCMR} range is referenced to the most positive side of the differential input signal.

(100K) ECL/LVECL DC ELECTRICAL CHARACTERISTICS⁽¹⁾ $V_{CC} = 0V$, $V_{EE} = -5.5V$ to $-3.0V$

Symbol	Parameter	$T_A = -40^\circ C$			$T_A = +25^\circ C$			$T_A = +85^\circ C$			Unit	Condition
		Min.	Typ.	Max.	Min.	Typ.	Max.	Min.	Typ.	Max.		
V_{IL}	Input LOW Voltage	-1945	—	-1625	-1945	—	-1625	-1945	—	-1625	mV	
V_{IH}	Input HIGH Voltage	-1225	—	-880	-1225	—	-880	-1225	—	-880	mV	
V_{OL}	Output LOW Voltage ⁽²⁾	-1945	-1820	-1695	-1945	-1820	-1695	-1945	-1820	-1695	mV	50Ω to $V_{CC}-2V$
V_{OH}	Output HIGH Voltage ⁽²⁾	-1145	-1020	-895	-1145	-1020	-895	-1145	-1020	-895	mV	50Ω to $V_{CC}-2V$
V_{BB}	Output Reference Voltage ⁽³⁾	-1525	-1425	-1325	-1525	-1425	-1325	-1525	-1425	-1325	mV	
V_{IHCMR}	Input HIGH Voltage Common Mode Range ⁽⁴⁾	$V_{EE} + 1.2$		0.0	$V_{EE} + 1.2$		0.0	$V_{EE} + 1.2$		0.0	V	

Note 1. 10EP circuits are designed to meet the DC specifications shown in the above table after thermal equilibrium has been established. The circuit is in a test socket or mounted on a printed circuit board and traverse airflow greater than 500lfpm is maintained. Input and output parameters vary 1:1 with V_{CC} .

Note 2. All loading with 50Ω to $V_{CC} - 2.0V$.

Note 3. Single-ended input operation is limited $V_{EE} \leq -3.0V$ in ECL/LVECL mode. V_{BB} reference varies 1:1 with V_{CC} .

Note 4. V_{IHCMR} (min) varies 1:1 with V_{EE} , (max) varies 1:1 with V_{CC} . The V_{IHCMR} is referenced to the most positive side of the differential input signal.

HSTL INPUT DC ELECTRICAL CHARACTERISTICS $V_{CC} = 2.37V$ to $3.8V$; $V_{EE} = 0V$

Symbol	Parameter	$T_A = -40^\circ C$			$T_A = +25^\circ C$			$T_A = +85^\circ C$			Unit
		Min.	Typ.	Max.	Min.	Typ.	Max.	Min.	Typ.	Max.	
V_{IH}	Input HIGH Voltage	1200	—	—	1200	—	—	1200	—	—	mV
V_{IL}	Input LOW Voltage	—	—	400	—	—	400	—	—	400	mV
V_X	Input Crossover Voltage	680	—	900	680	—	900	680	—	900	mV

AC ELECTRICAL CHARACTERISTICS

LVPECL: $V_{CC} = 2.37V$ to $2.625V$, $V_{EE} = 0V$; PECL: $V_{CC} = 4.50V$ to $5.50V$, $V_{EE} = 0V$;
 ECL: $V_{EE} = -4.50V$ to $-5.5V$, $V_{CC} = 0V$; LVECL: $V_{EE} = -2.37V$ to $-3.8V$, $V_{CC} = 0V$

Symbol	Parameter	$T_A = -40^\circ C$			$T_A = +25^\circ C$			$T_A = +85^\circ C$			Unit
		Min.	Typ.	Max.	Min.	Typ.	Max.	Min.	Typ.	Max.	
f_{MAX}	Maximum Frequency ⁽¹⁾	2	—	—	2	—	—	2	—	—	GHz
t_{PLH} t_{PHL}	PECL/ECL ($V_{CC} = 5V$) Propagation Delay to Output IN (Differential) IN (Single-Ended)	250 —	330 —	400 —	250 —	330 355	450 —	250 —	330 —	600 —	ps ps
	LVPECL/LVECL ($V_{CC} = 2.37V$ to $3.8V$) Propagation Delay to Output IN (Differential) IN (Single-Ended)	275 —	350 —	425 —	275 —	350 375	475 —	275 —	350 —	525 —	ps ps
$t_{SKEW}^{(2)}$	PECL/ECL ($V_{CC} = 5V$) Within-Device Skew (Diff.) Part-to-Part Skew (Diff.)	— —	25 100	35 125	— —	30 150	45 175	— —	40 175	50 200	ps ps
	LVPECL/LVECL ($V_{CC} = 2.37V$ to $3.8V$) Within-Device Skew (Diff.) Part-to-Part Skew (Diff.)	— —	10 100	25 125	— —	15 150	25 175	— —	15 200	25 225	ps ps
t_S	Set-Up Time ⁽³⁾ /EN to CLK	100	50	—	100	50	—	100	50	—	ps
t_H	Hold Time ⁽³⁾ /EN to CLK	200	140	—	200	140	—	200	140	—	ps
V_{PP}	Minimum Input Swing	150	800	1200	150	800	1200	150	800	1200	mV
t_r, t_f	PECL/ECL Output Rise/Fall Times (20% to 80%) LVPECL/LVECL ($V_{CC} = 2.37V$ to $3.8V$)	100 90	180 130	240 225	105 95	180 130	270 250	110 100	225 150	300 275	ps ps

Note 1. f_{MAX} is defined as the maximum toggle frequency. Measured with 750mV input signal, 50% duty cycle, all loading with 50W to $V_{CC}-2V$.

Note 2. Skew is measured between outputs under identical transitions.

Note 3. Set-up and hold times apply to synchronous applications that intend to enable/disable before then ext clock cycle. For asynchronous applications, set-up and hold time does not apply.

TERMINATION RECOMMENDATIONS

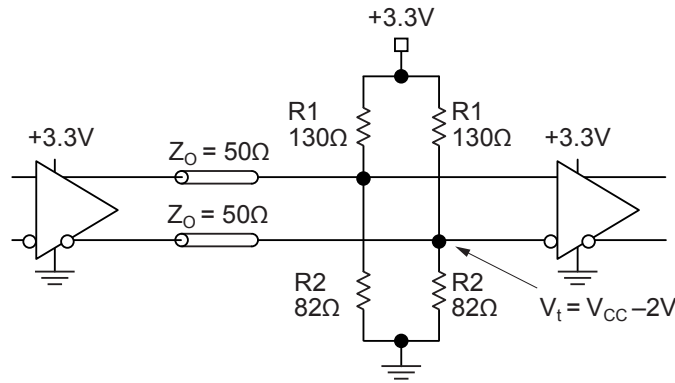

Figure 1. Parallel Termination-Thevenin Equivalent

Note 1. For +2.5V systems: R1 = 250Ω, R2 = 62.5Ω

Note 2. For +5.0V systems: R1 = 82Ω, R2 = 130Ω

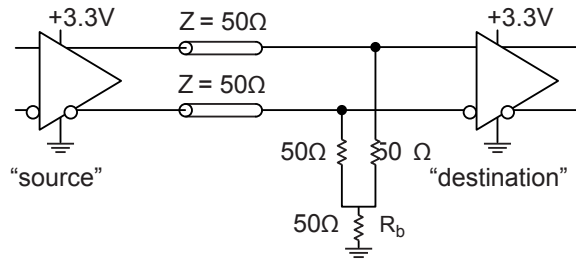

Figure 2. Three-Resistor "Y-Termination"

Note 1. Power-saving alternative to Thevenin termination.

Note 2. Place termination resistors as close to destination inputs as possible.

Note 3. R_b resistor sets the DC bias voltage, equal to V_t. For +3.3V systems R_b = 46Ω to 50Ω. For +5V systems, R_b = 110Ω.

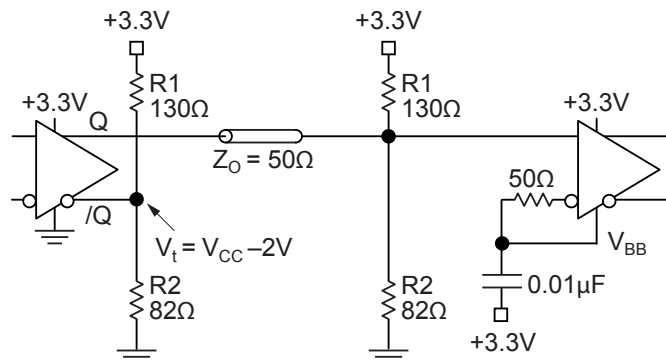

Figure 3. Terminating Unused I/O

Note 1. Unused output (/Q) must be terminated to balance the output.

Note 2. Micrel's differential I/O logic devices include a V_{BB} reference pin .

Note 3. Connect unused input through 50Ω to V_{BB}. Bypass with a 0.01μF capacitor to V_{CC}, not GND.

Note 4. For +2.5V systems: R1 = 250Ω, R2 = 62.5Ω.

20-PIN TSSOP (K4-20-1)

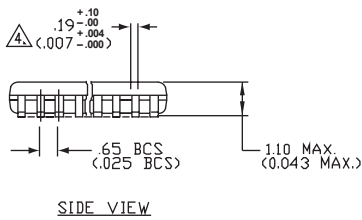
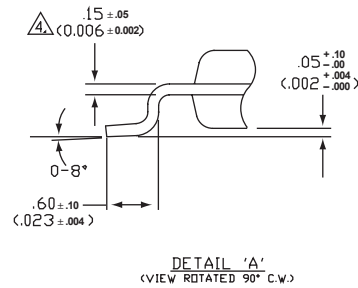
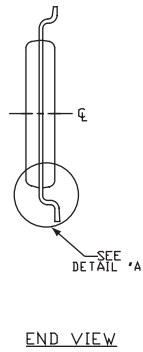
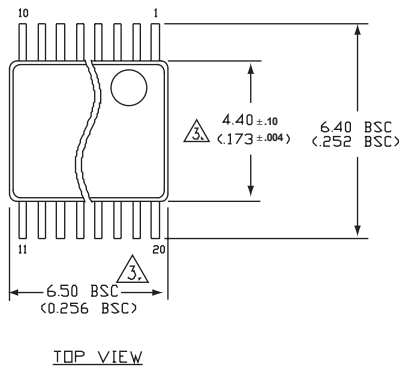

- NOTES:
1. DIMENSIONS ARE IN MM[INCHES].
 2. CONTROLLING DIMENSION: MM
 3. DIMENSION DOES NOT INCLUDE MOLD FLASH OF 0.254[0.010] MAX.
 4. THIS DIMENSION INCLUDES LEAD FINISH.

Rev.01

Package Notes:

Note 1. Package meets Level 1 moisture sensitivity.

MICREL, INC. 2180 FORTUNE DRIVE SAN JOSE, CA 95131 USA

TEL + 1 (408) 944-0800 FAX + 1 (408) 474-1000 WEB <http://www.micrel.com>

The information furnished by Micrel in this datasheet is believed to be accurate and reliable. However, no responsibility is assumed by Micrel for its use. Micrel reserves the right to change circuitry and specifications at any time without notification to the customer.

Micrel Products are not designed or authorized for use as components in life support appliances, devices or systems where malfunction of a product can reasonably be expected to result in personal injury. Life support devices or systems are devices or systems that (a) are intended for surgical implant into the body or (b) support or sustain life, and whose failure to perform can be reasonably expected to result in a significant injury to the user. A Purchaser's use or sale of Micrel Products for use in life support appliances, devices or systems is at Purchaser's own risk and Purchaser agrees to fully indemnify Micrel for any damages resulting from such use or sale.

© 2005 Micrel, Incorporated.

Looking for pricing, stock, or lifecycle information?

Click below to explore more details on WIN SOURCE:

 [View SY100EP14UK4I on WIN SOURCE](#)

 [Microchip Technology](#) Information

Optimize Your Supply Chain with WIN SOURCE Solutions

-  Global Sourcing Solution
-  Obsolete Management
-  Cost Control Management
-  Shortage Management
-  Alternative Solution
-  Excess Inventory Management