



**THE DATASHEET OF
OPA2354AQDGKRQ1**



OPAx354-Q1 250-MHz, Rail-to-Rail I/O, CMOS Operational Amplifiers

1 Features

- Qualified for Automotive Applications
- AEC-Q100 Qualified With the Following Results:
 - Device Temperature Grade: -40°C to $+125^{\circ}\text{C}$ Ambient Operating Temperature Range
 - Device HBM ESD Classification Level 2
 - Device CDM ESD Classification Level:
 - C6 for OPA354A-Q1 and OPA2354A-Q1
 - C3 for OPA4354-Q1
- Unity-Gain Bandwidth: 250 MHz
- Wide Bandwidth: 100-MHz GBW Product
- High Slew Rate: 150 V/ μs
- Low Noise: 6.5 nV/ $\sqrt{\text{Hz}}$
- Rail-to-Rail I/O
- High Output Current: >100 mA
- Excellent Video Performance
 - Differential Gain Error: 0.02%
 - Differential Phase Error: 0.09°
 - 0.1-dB Gain Flatness: 40 MHz
- Low Input Bias Current: 3 pA
- Quiescent Current: 4.9 mA
- Thermal Shutdown
- Supply Range: 2.5 V to 5.5 V

2 Applications

- Navigation and Radio System
- Blind-Spot Detection
- Short-to-Mid Range Radar
- Video Processing
- Ultrasound
- Optical Networking, Tunable Lasers
- Photodiode Transimpedance Amplifiers
- Active Filters
- High-Speed Integrators
- Analog-to-Digital Converter (ADC) Input Buffers
- Digital-to-Analog Converter (DAC) Output Amplifiers
- Barcode Scanners
- Communications

3 Description

The design of the OPAx354-Q1 family of high-speed, voltage-feedback CMOS operational amplifiers is for video and other applications requiring wide bandwidth. These devices are unity-gain stable and can drive large output currents. Differential gain is 0.02% and differential phase is 0.09° . Quiescent current is only 4.9 mA per channel.

The OPAx354-Q1 family of operational amplifiers (op-amps) are optimized for operation on single or dual supplies as low as 2.5 V (± 1.25 V) and up to 5.5 V (± 2.75 V). Common-mode input range extends beyond the supplies. The output swing is within 100 mV of the rails, supporting wide dynamic range.

The single-supply version (OPA354A-Q1) is available in the tiny SOT-23-5 (DBV) package. The dual-supply version (OPA2354A-Q1) is available in the miniature VSSOP-8 (DGK) package and features completely independent circuitry for lowest crosstalk and freedom from interaction. The quad-supply version (OPA4354-Q1) is available in the TSSOP-14 (PW) package. The device specifications are for operation over the automotive temperature range of -40°C to $+125^{\circ}\text{C}$.

Device Information⁽¹⁾

| PART NUMBER | PACKAGE (PIN) | BODY SIZE (NOM) |
|-------------|---------------|-------------------|
| OPA354A-Q1 | SOT-23 (5) | 2.90 mm x 1.60 mm |
| OPA2354A-Q1 | VSSOP (8) | 3.00 mm x 3.00 mm |
| OPA4354-Q1 | TSSOP (14) | 5.00 mm x 4.40 mm |

(1) For all available packages, see the orderable addendum at the end of the data sheet.

Simplified Schematic

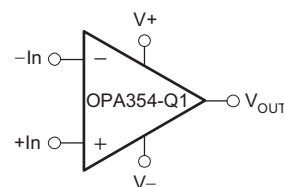

Table of Contents

| | | | |
|------------------------------------------------|-----------|------------------------------------------------------------------|-----------|
| 1 Features | 1 | 7.4 Device Functional Modes..... | 20 |
| 2 Applications | 1 | 8 Application and Implementation | 21 |
| 3 Description | 1 | 8.1 Application Information..... | 21 |
| 4 Revision History | 2 | 8.2 Typical Applications | 21 |
| 5 Pin Configuration and Functions | 3 | 9 Power Supply Recommendations | 25 |
| 6 Specifications | 6 | 9.1 Power Dissipation | 26 |
| 6.1 Absolute Maximum Ratings | 6 | 10 Layout | 26 |
| 6.2 ESD Ratings..... | 6 | 10.1 Layout Guidelines | 26 |
| 6.3 Recommended Operating Conditions..... | 6 | 10.2 Layout Example | 27 |
| 6.4 Thermal Information: OPA354A-Q1 | 6 | 11 Device and Documentation Support | 28 |
| 6.5 Thermal Information: OPA2354A-Q1 | 7 | 11.1 Documentation Support | 28 |
| 6.6 Thermal Information: OPA4354A-Q1 | 7 | 11.2 Related Links | 28 |
| 6.7 Electrical Characteristics..... | 8 | 11.3 Receiving Notification of Documentation Updates | 28 |
| 6.8 Typical Characteristics..... | 10 | 11.4 Community Resources..... | 28 |
| 7 Detailed Description | 15 | 11.5 Trademarks | 28 |
| 7.1 Overview | 15 | 11.6 Electrostatic Discharge Caution..... | 29 |
| 7.2 Functional Block Diagram | 15 | 11.7 Glossary | 29 |
| 7.3 Feature Description..... | 15 | 12 Mechanical, Packaging, and Orderable Information | 29 |

4 Revision History

NOTE: Page numbers for previous revisions may differ from page numbers in the current version.

| Changes from Revision E (August 2016) to Revision F | Page |
|---------------------------------------------------------------------------------------------------------------|-------------|
| • Deleted table note about input terminals and input signals from <i>Absolute Maximum Ratings</i> table | 6 |

| Changes from Revision D (July 2016) to Revision E | Page |
|----------------------------------------------------------------------------------------------------------------------------------|-------------|
| • Changed the gain-bandwidth product typical value from 10 MHz back to 100 MHz in the <i>Electrical Characteristics</i> table .. | 8 |

| Changes from Revision C (June 2016) to Revision D | Page |
|-------------------------------------------------------------------------------------------------------------------------------|-------------|
| • Changed the gain-bandwidth product typical value from 100 MHz to 10 MHz in the <i>Electrical Characteristics</i> table..... | 8 |
| • Added the <i>Receiving Notification of Documentation Updates</i> and <i>Community Resources</i> sections | 28 |

| Changes from Revision B (December 2014) to Revision C | Page |
|-------------------------------------------------------------------------------------------|-------------|
| • Added 3 additional applications to the <i>Applications</i> section | 1 |
| • Updated <i>ESD Ratings</i> table to show CDM value for OPA354A-Q1 and OPA2354A-Q1 | 6 |

| Changes from Revision A (August 2009) to Revision B | Page |
|---------------------------------------------------------------------------------------------------------------------------------------------------------------------------------------------------------------------------------------------------------------------------------------------------------------------------------------------------------|-------------|
| • Added <i>Handling Rating</i> table, <i>Feature Description</i> section, <i>Device Functional Modes</i> , <i>Application and Implementation</i> section, <i>Power Supply Recommendations</i> section, <i>Layout</i> section, <i>Device and Documentation Support</i> section, and <i>Mechanical, Packaging, and Orderable Information</i> section..... | 1 |
| • Added the OPA4354-Q1 device to the data sheet | 1 |

5 Pin Configuration and Functions

**OPA354A-Q1 DBV Package
5-Pin SOT-23
Top View**

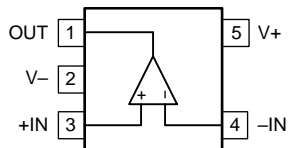

Pin Functions: OPA354A-Q1

| PIN | | I/O | DESCRIPTION |
|------|-----|-----|---------------------------|
| NAME | NO. | | |
| +IN | 3 | I | Noninverting input |
| -IN | 4 | I | Inverting input |
| OUT | 1 | O | Output |
| V+ | 5 | — | Positive (highest) supply |
| V- | 2 | — | Negative (lowest) supply |

**OPA2354A-Q1 DGK Package
8-Pin VSSOP
Top View**

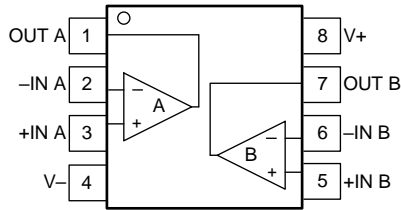

Pin Functions: OPA2354A-Q1

| PIN | | I/O | DESCRIPTION |
|-------|-----|-----|-------------------------------|
| NAME | NO. | | |
| +IN A | 3 | I | Noninverting input, channel A |
| +IN B | 5 | I | Noninverting input, channel B |
| -IN A | 2 | I | Inverting input, channel A |
| -IN B | 6 | I | Inverting input, channel B |
| OUT A | 1 | O | Output, channel A |
| OUT B | 7 | O | Output, channel B |
| V+ | 8 | — | Positive (highest) supply |
| V- | 4 | — | Negative (lowest) supply |

**OPA4354-Q1 PW Package
14-Pin TSSOP
Top View**

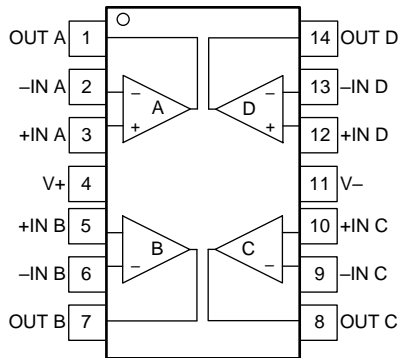

Pin Functions: OPA4354-Q1

| PIN | | I/O | DESCRIPTION |
|-------|-----|-----|-------------------------------|
| NAME | NO. | | |
| +IN A | 3 | I | Noninverting input, channel A |
| +IN B | 5 | I | Noninverting input, channel B |
| +IN C | 10 | I | Noninverting input, channel C |
| +IN D | 12 | I | Noninverting input, channel D |
| -IN A | 2 | I | Inverting input, channel A |
| -IN B | 6 | I | Inverting input, channel B |
| -IN C | 9 | I | Inverting input, channel C |
| -IN D | 13 | I | Inverting input, channel D |
| OUT A | 1 | O | Output, channel A |
| OUT B | 7 | O | Output, channel B |
| OUT C | 1 | O | Output, channel C |
| OUT D | 7 | O | Output, channel D |
| V+ | 5 | — | Positive (highest) supply |
| V- | 2 | — | Negative (lowest) supply |

6 Specifications

6.1 Absolute Maximum Ratings

over operating free-air temperature range (unless otherwise noted) ⁽¹⁾

| | MIN | MAX | UNIT |
|-------------------------------------------------|------------|------------|------|
| Supply voltage, V+ to V–, V _S | | 7.5 | V |
| Signal input terminals voltage, V _{IN} | (V–) – 0.5 | (V+) + 0.5 | V |
| Output short-circuit duration ⁽²⁾ | Continuous | | |
| Operating temperature, T _A | –55 | 150 | °C |
| Junction temperature, T _J | | 150 | °C |
| Storage temperature, T _{stg} | –65 | 150 | °C |

- (1) Stresses beyond those listed under *Absolute Maximum Ratings* may cause permanent damage to the device. These are stress ratings only, which do not imply functional operation of the device at these or any other conditions beyond those indicated under *Recommended Operating Conditions*. Exposure to absolute-maximum-rated conditions for extended periods may affect device reliability.
- (2) Short circuit to ground, one amplifier per package

6.2 ESD Ratings

| | | VALUE | UNIT |
|----------------------------------------------------------------------------------|-------------------------|---------------------------------------------------------|-------|
| OPA354A-Q1 IN DBV (SOT-23) PACKAGE AND OPA2354A-Q1 IN DGK (VSSOP) PACKAGE | | | |
| V _(ESD) | Electrostatic discharge | Human body model (HBM), per AEC Q100-002 ⁽¹⁾ | ±2000 |
| | | Charged device model (CDM), per AEC Q100-011 | ±1000 |
| OPA4354-Q1 IN PW (TSSOP) PACKAGE | | | |
| V _(ESD) | Electrostatic discharge | Human body model (HBM), per AEC Q100-002 ⁽¹⁾ | ±2000 |
| | | Charged device model (CDM), per AEC Q100-011 | ±250 |

- (1) AEC Q100-002 indicates HBM stressing is done in accordance with the ANSI/ESDA/JEDEC JS-001 specification.

6.3 Recommended Operating Conditions

over operating free-air temperature range (unless otherwise noted)

| | MIN | MAX | UNIT |
|-----------------------------------------------|-----|-----|------|
| V _S Supply voltage, V– to V+ | 2.5 | 5.5 | V |
| T _A Operating free-air temperature | –40 | 125 | °C |

6.4 Thermal Information: OPA354A-Q1

| THERMAL METRIC ⁽¹⁾ | OPA354A-Q1 | OPA2354A-Q1 | OPA4354-Q1 | UNIT |
|--------------------------------------------------------------------|--------------|-------------|------------|------|
| | DBV (SOT-23) | DGK (VSSOP) | PW (TSSOP) | |
| | 5 PINS | 8 PINS | 14 PINS | |
| R _{θJA} Junction-to-ambient thermal resistance | 216.3 | 175.9 | 92.6 | °C/W |
| R _{θJC(top)} Junction-to-case (top) thermal resistance | 84.3 | 67.8 | 27.5 | °C/W |
| R _{θJB} Junction-to-board thermal resistance | 43.1 | 97.1 | 33.6 | °C/W |
| ψ _{JT} Junction-to-top characterization parameter | 3.8 | 9.3 | 1.9 | °C/W |
| ψ _{JB} Junction-to-board characterization parameter | 42.3 | 95.5 | 33.1 | °C/W |
| R _{θJC(bot)} Junction-to-case (bottom) thermal resistance | N/A | N/A | N/A | °C/W |

- (1) For more information about traditional and new thermal metrics, see the [Semiconductor and IC Package Thermal Metrics](#) application report.

6.5 Thermal Information: OPA2354A-Q1

| THERMAL METRIC ⁽¹⁾ | | OPA2354A-Q1 | |
|-------------------------------|----------------------------------------------|-------------|------|
| | | DGK (VSSOP) | |
| | | 8 PINS | |
| | | | UNIT |
| $R_{\theta JA}$ | Junction-to-ambient thermal resistance | 175.9 | °C/W |
| $R_{\theta JC(top)}$ | Junction-to-case (top) thermal resistance | 67.8 | °C/W |
| $R_{\theta JB}$ | Junction-to-board thermal resistance | 97.1 | °C/W |
| Ψ_{JT} | Junction-to-top characterization parameter | 9.3 | °C/W |
| Ψ_{JB} | Junction-to-board characterization parameter | 95.5 | °C/W |
| $R_{\theta JC(bot)}$ | Junction-to-case (bottom) thermal resistance | N/A | °C/W |

(1) For more information about traditional and new thermal metrics, see the [Semiconductor and IC Package Thermal Metrics](#) application report.

6.6 Thermal Information: OPA4354A-Q1

| THERMAL METRIC ⁽¹⁾ | | OPA4354-Q1 | |
|-------------------------------|----------------------------------------------|------------|------|
| | | PW (TSSOP) | |
| | | 14 PINS | |
| | | | UNIT |
| $R_{\theta JA}$ | Junction-to-ambient thermal resistance | 92.6 | °C/W |
| $R_{\theta JC(top)}$ | Junction-to-case (top) thermal resistance | 27.5 | °C/W |
| $R_{\theta JB}$ | Junction-to-board thermal resistance | 33.6 | °C/W |
| Ψ_{JT} | Junction-to-top characterization parameter | 1.9 | °C/W |
| Ψ_{JB} | Junction-to-board characterization parameter | 33.1 | °C/W |
| $R_{\theta JC(bot)}$ | Junction-to-case (bottom) thermal resistance | N/A | °C/W |

(1) For more information about traditional and new thermal metrics, see the [Semiconductor and IC Package Thermal Metrics](#) application report.

6.7 Electrical Characteristics

 $V_S = 2.5\text{ V to } 5.5\text{ V}$, R_F (feedback resistor) = 0 Ω , R_L (load resistor) = 1 k Ω connected to $V_S / 2$ (unless otherwise noted)

| PARAMETER | | TEST CONDITIONS | | MIN | TYP | MAX | UNIT |
|----------------------------|---------------------------------------|-------------------------------------------------------------------------------------------------------------------------------------|-------------------------------------------------------|------------|-----------------------|------------------------------|------------------------------|
| V_{OS} | Input offset voltage | $V_S = 5\text{ V}$ $V_{CM} = (V-) + 0.8\text{ V}$ | $T_A = 25^\circ\text{C}$ $T_A = \text{Full range}$ | | ± 2 | ± 8 ± 10 | mV |
| $\Delta V_{OS} / \Delta T$ | Offset voltage drift over temperature | $T_A = \text{Full range}$ | | | ± 4 | | $\mu\text{V}/^\circ\text{C}$ |
| PSRR | Offset voltage drift vs power supply | $V_S = 2.7\text{ V to } 5.5\text{ V}$, $V_{CM} = V_S / 2 - 0.15\text{ V}$ | $T_A = 25^\circ\text{C}$ $T_A = \text{Full range}$ | | ± 200 | ± 800 ± 900 | $\mu\text{V}/\text{V}$ |
| I_B | Input bias current | $T_A = 25^\circ\text{C}$ | | | 3 | ± 50 | pA |
| I_{OS} | Input offset current | $T_A = 25^\circ\text{C}$ | | | ± 1 | ± 50 | pA |
| V_n | Input voltage noise density | $f = 1\text{ MHz}$, $T_A = 25^\circ\text{C}$ | | | 6.5 | | $\text{nV}/\sqrt{\text{Hz}}$ |
| I_n | Input current noise density | $f = 1\text{ MHz}$, $T_A = 25^\circ\text{C}$ | | | 50 | | $\text{fA}/\sqrt{\text{Hz}}$ |
| V_{CM} | Input common-mode voltage range | $T_A = 25^\circ\text{C}$ | | (V-) – 0.1 | | (V+) + 0.1 | V |
| CMRR | Input common-mode rejection ratio | $V_S = 5.5\text{ V}$ $-0.1\text{ V} < V_{CM} < 3.5\text{ V}$ | $T_A = 25^\circ\text{C}$ | 66 | 80 | dB | |
| | | | $T_A = \text{Full range}$ | 64 | | | |
| | | $V_S = 5.5\text{ V}$ $-0.1\text{ V} < V_{CM} < 5.6\text{ V}$ | $T_A = 25^\circ\text{C}$ | 56 | 68 | | |
| | | | $T_A = \text{Full range}$ | 55 | | | |
| Z_{ID} | Differential input impedance | $T_A = 25^\circ\text{C}$ | | | $10^{13} \parallel 2$ | $\Omega \parallel \text{pF}$ | |
| Z_{ICM} | Common-mode input impedance | $T_A = 25^\circ\text{C}$ | | | $10^{13} \parallel 2$ | $\Omega \parallel \text{pF}$ | |
| A_{OL} | Open-loop gain | $V_S = 5\text{ V}$, $0.3\text{ V} < V_O < 4.7\text{ V}$ $T_A = 25^\circ\text{C}$ | | 94 | 110 | dB | |
| | | $V_S = 5\text{ V}$, $0.4\text{ V} < V_O < 4.6\text{ V}$ $T_A = \text{Full range}$ | | 90 | | | |
| f_{-3dB} | Small-signal bandwidth | $G = 1$, $V_O = 100\text{ mVp-p}$, $R_F = 25\ \Omega$, $T_A = 25^\circ\text{C}$ | | | 250 | MHz | |
| | | $G = 2$, $V_O = 100\text{ mVp-p}$, $T_A = 25^\circ\text{C}$ | | | 90 | | |
| GBW | Gain-bandwidth product | $G = 10$ $T_A = 25^\circ\text{C}$ | | | 100 | MHz | |
| $f_{0.1dB}$ | Bandwidth for 0.1-dB gain flatness | $G = 2$, $V_O = 100\text{ mVp-p}$, $T_A = 25^\circ\text{C}$ | | | 40 | MHz | |
| SR | Slew rate | $V_S = 5\text{ V}$, $G = 1$, 4-V step, $T_A = 25^\circ\text{C}$ | | | 150 | V/ μs | |
| | | $V_S = 5\text{ V}$, $G = 1$, 2-V step | | | 130 | | |
| | | $V_S = 3\text{ V}$, $G = 1$, 2-V step | | | 110 | | |
| t_{rf} | Rise-and-fall time | $G = 1$, $V_O = 200\text{ mVp-p}$, 10% to 90%, $T_A = 25^\circ\text{C}$ | | | 2 | ns | |
| | | $G = 1$, $V_O = 2\text{ Vp-p}$, 10% to 90%, $T_A = 25^\circ\text{C}$ | | | 11 | | |
| t_{settle} | Settling time | $V_S = 5\text{ V}$, $G = +1$, 2-V output step, $T_A = 25^\circ\text{C}$ | 0.1% | | 30 | ns | |
| | | | 0.01% | | 60 | | |
| | Overload recovery time | $V_{IN} \times \text{Gain} = V_S$ $T_A = 25^\circ\text{C}$ | | | 5 | ns | |
| | Second-order harmonic distortion | $G = 1$, $f = 1\text{ MHz}$, $V_O = 2\text{ Vp-p}$, $R_L = 200\ \Omega$, $V_{CM} = 1.5\text{ V}$ $T_A = 25^\circ\text{C}$ | | | -75 | dBc | |
| | Third-order harmonic distortion | $G = 1$, $f = 1\text{ MHz}$, $V_O = 2\text{ Vp-p}$, $R_L = 200\ \Omega$, $V_{CM} = 1.5\text{ V}$ $T_A = 25^\circ\text{C}$ | | | -83 | dBc | |
| | Differential gain error | NTSC, $R_L = 150\ \Omega$, $T_A = 25^\circ\text{C}$ | | | 0.02% | | |
| | Differential phase error | NTSC, $R_L = 150\ \Omega$, $T_A = 25^\circ\text{C}$ | | | 0.09 | ° | |

Electrical Characteristics (continued)
 $V_S = 2.5\text{ V to }5.5\text{ V}$, R_F (feedback resistor) = 0 Ω , R_L (load resistor) = 1 k Ω connected to $V_S / 2$ (unless otherwise noted)

| PARAMETER | TEST CONDITIONS | MIN | TYP | MAX | UNIT |
|---------------------------------------------------------|------------------------------------------------------------------------------------------------------|---------------------------|------|-----|------------------|
| Channel-to-channel crosstalk (OPA2354A-Q1) (OPA4354-Q1) | $f = 5\text{ MHz}$, $T_A = 25^\circ\text{C}$ | | -100 | | dB |
| Voltage output swing from rail | $V_S = 5\text{ V}$, $R_L = 1\text{ k}\Omega$, $A_{OL} > 94\text{ dB}$ $T_A = 25^\circ\text{C}$ | | 0.1 | 0.3 | V |
| | $V_S = 5\text{ V}$, $R_L = 1\text{ k}\Omega$ $A_{OL} > 90\text{ dB}$, $T_A = \text{Full range}$ | | | 0.4 | |
| I_O Output current ⁽¹⁾⁽²⁾ | $V_S = 5\text{ V}$ | 100 | | | mA |
| | $V_S = 3\text{ V}$ | | 50 | | |
| Closed-loop output impedance | $f < 100\text{ kHz}$ | | 0.05 | | Ω |
| R_O Open-loop output resistance | | | 35 | | Ω |
| I_Q Quiescent current (per amplifier) | $V_S = 5\text{ V}$, $I_O = 0$, enabled | $T_A = 25^\circ\text{C}$ | 4.9 | 6 | mA |
| | | $T_A = \text{Full range}$ | | 7.5 | |
| Thermal shutdown junction temperature | Shutdown | | 160 | | $^\circ\text{C}$ |
| | Reset from shutdown | | 140 | | |

 (1) See typical characteristic graph *Output Voltage Swing vs Output Current* (Figure 20).

(2) Not production tested

6.8 Typical Characteristics

$T_A = 25^\circ\text{C}$, $V_S = 5\text{ V}$, $R_F = 0\ \Omega$, $R_L = 1\ \text{k}\Omega$ connected to $V_S / 2$ (unless otherwise noted)

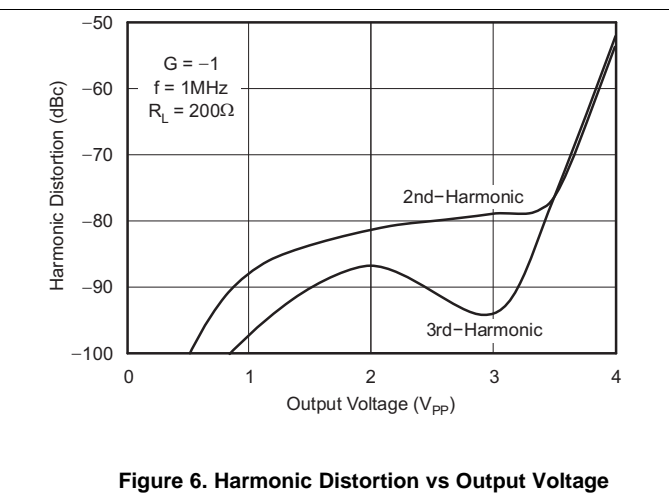
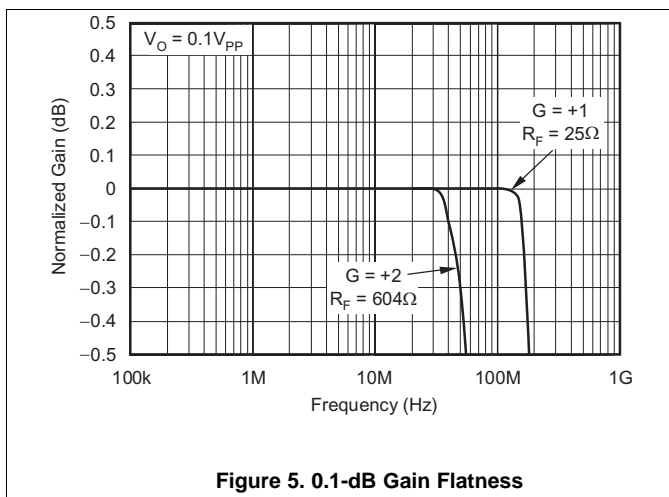
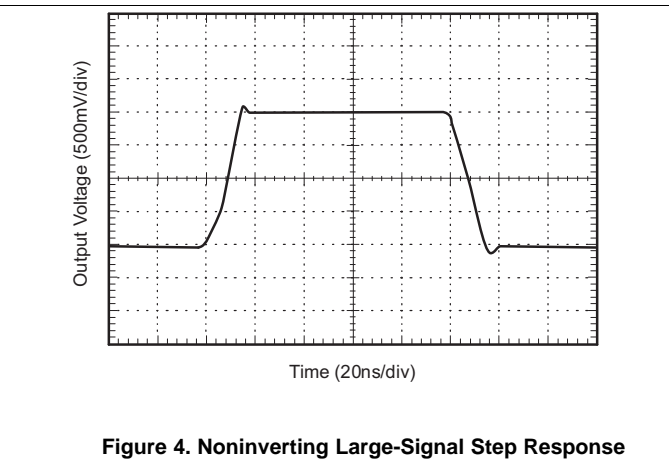
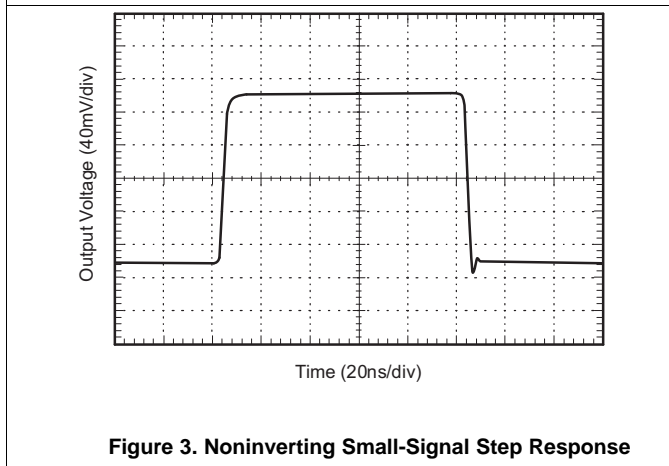
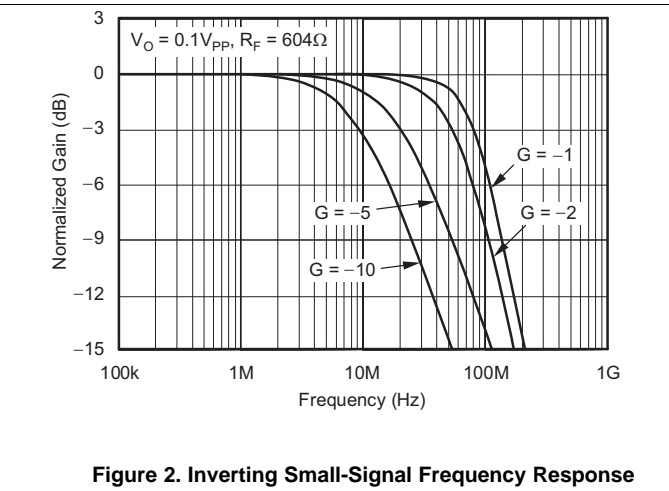
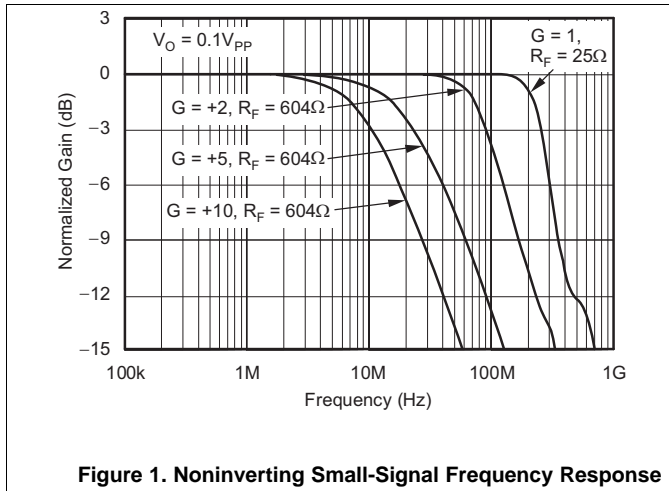

Typical Characteristics (continued)

$T_A = 25^\circ\text{C}$, $V_S = 5\text{ V}$, $R_F = 0\ \Omega$, $R_L = 1\ \text{k}\Omega$ connected to $V_S / 2$ (unless otherwise noted)

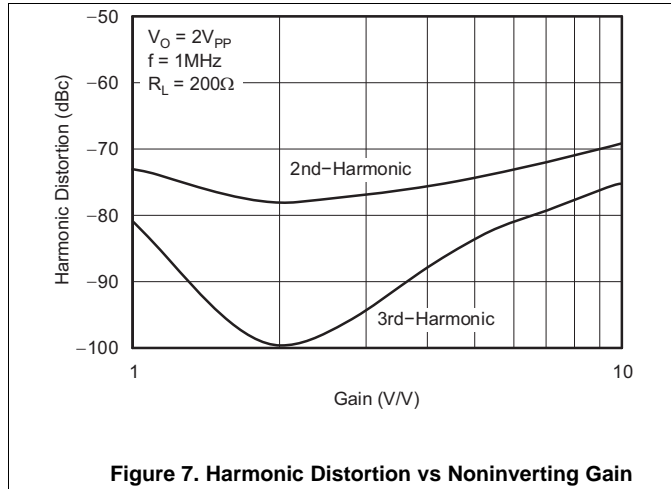

Figure 7. Harmonic Distortion vs Noninverting Gain

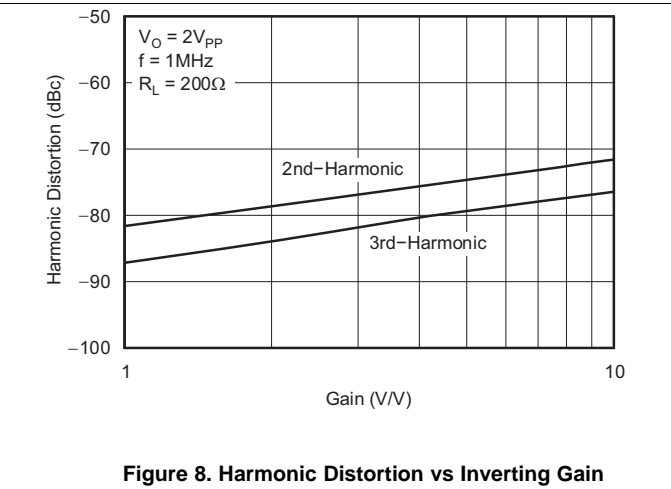

Figure 8. Harmonic Distortion vs Inverting Gain

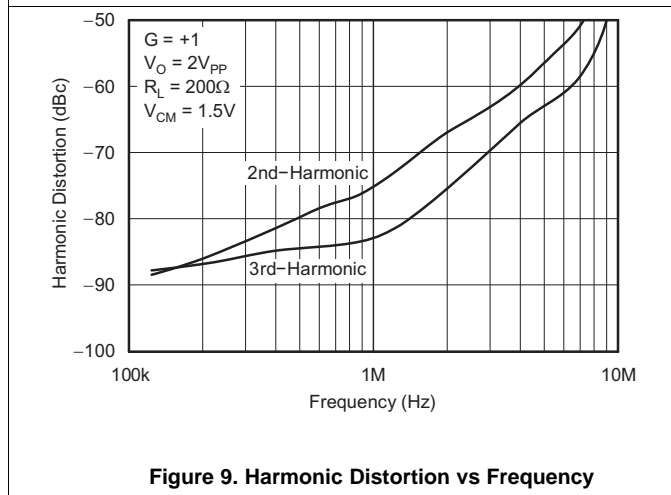

Figure 9. Harmonic Distortion vs Frequency

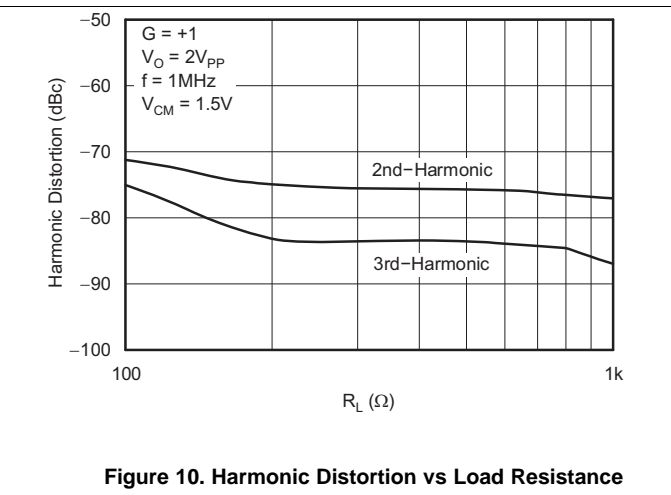

Figure 10. Harmonic Distortion vs Load Resistance

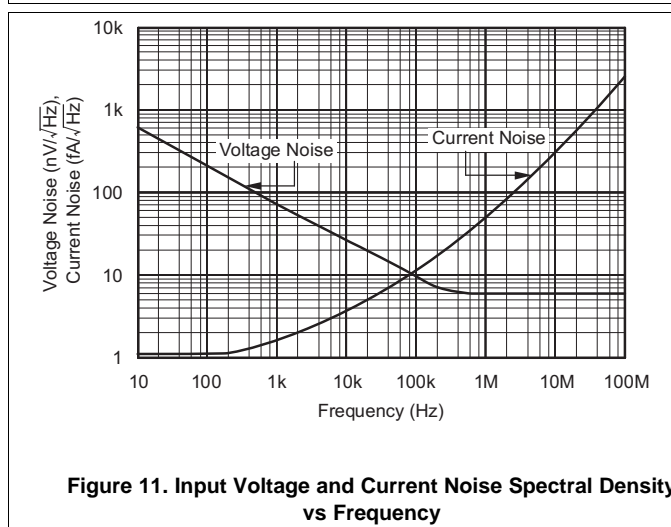

Figure 11. Input Voltage and Current Noise Spectral Density vs Frequency

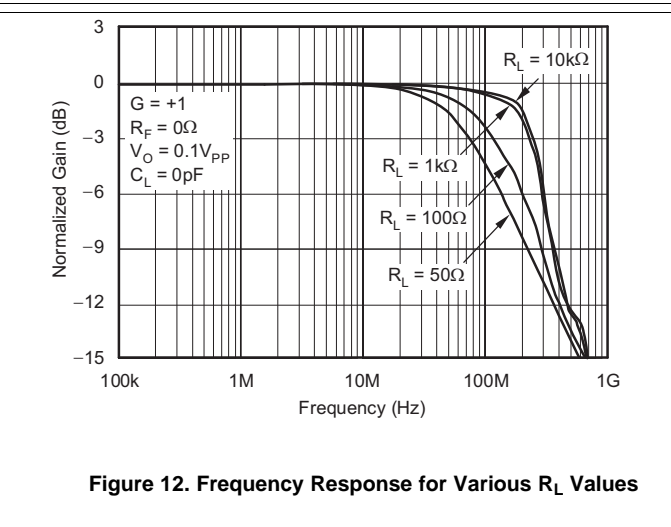

Figure 12. Frequency Response for Various R_L Values

Typical Characteristics (continued)

$T_A = 25^\circ\text{C}$, $V_S = 5\text{ V}$, $R_F = 0\ \Omega$, $R_L = 1\ \text{k}\Omega$ connected to $V_S / 2$ (unless otherwise noted)

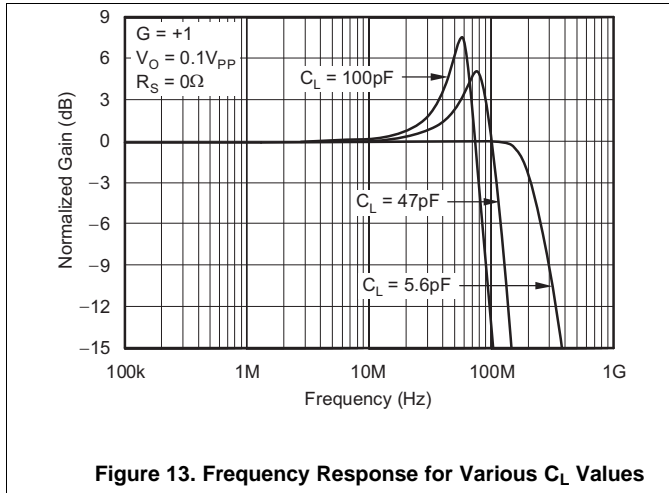

Figure 13. Frequency Response for Various C_L Values

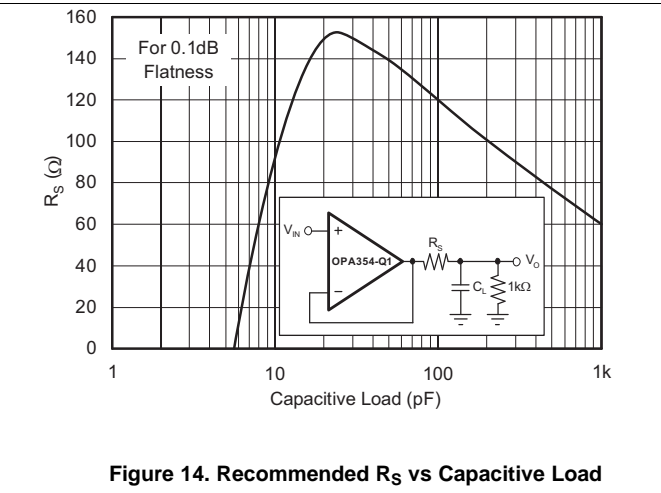

Figure 14. Recommended R_S vs Capacitive Load

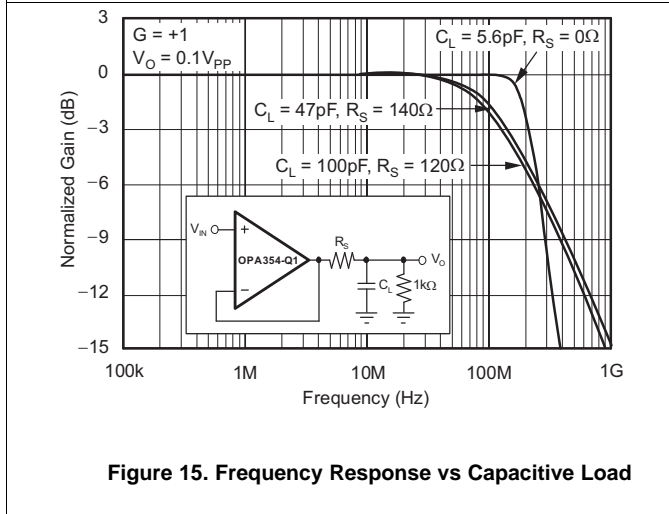

Figure 15. Frequency Response vs Capacitive Load

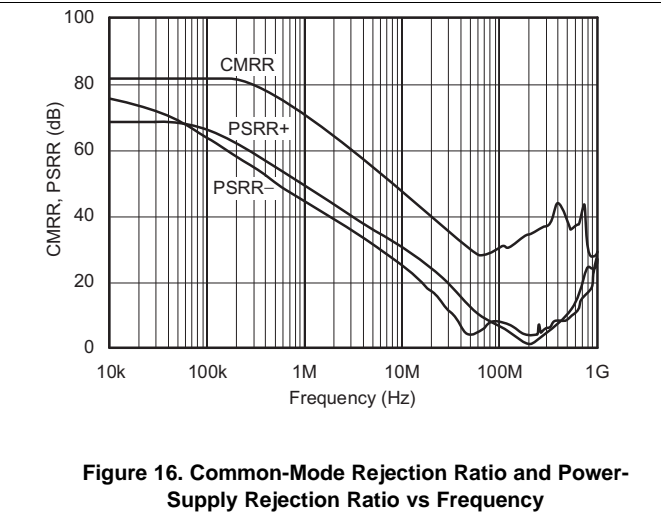

Figure 16. Common-Mode Rejection Ratio and Power-Supply Rejection Ratio vs Frequency

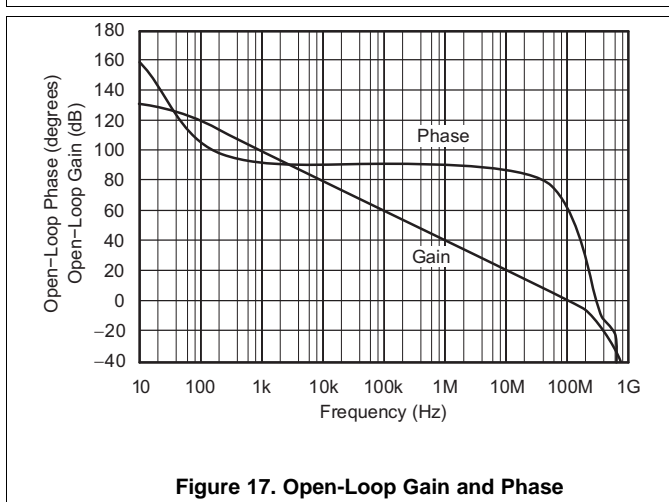

Figure 17. Open-Loop Gain and Phase

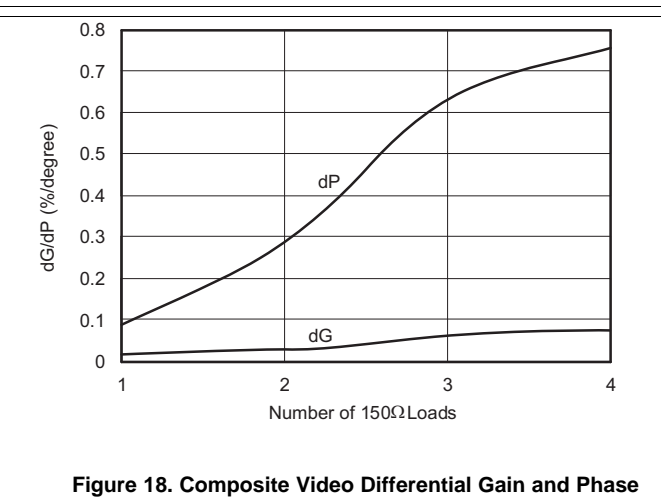

Figure 18. Composite Video Differential Gain and Phase

Typical Characteristics (continued)

$T_A = 25^\circ\text{C}$, $V_S = 5\text{ V}$, $R_F = 0\ \Omega$, $R_L = 1\ \text{k}\Omega$ connected to $V_S / 2$ (unless otherwise noted)

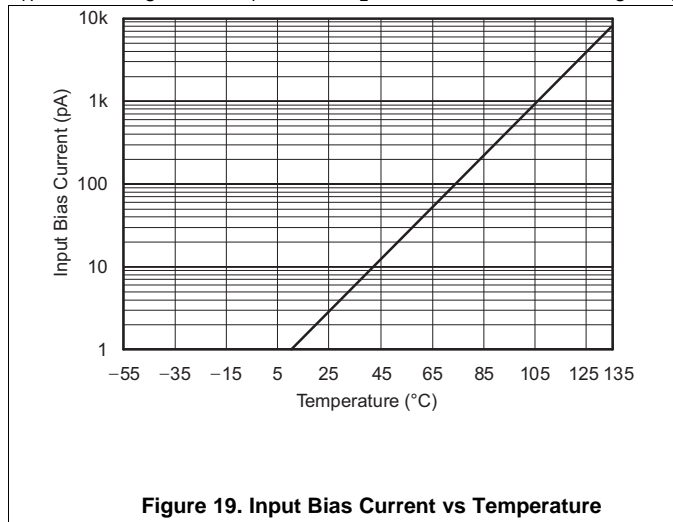

Figure 19. Input Bias Current vs Temperature

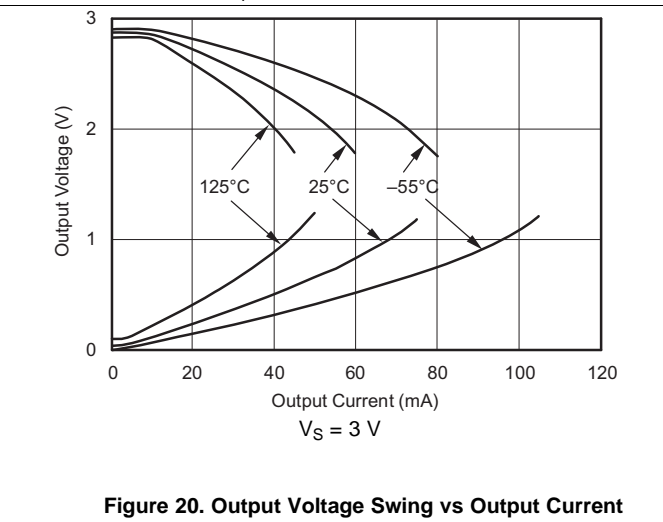

Figure 20. Output Voltage Swing vs Output Current

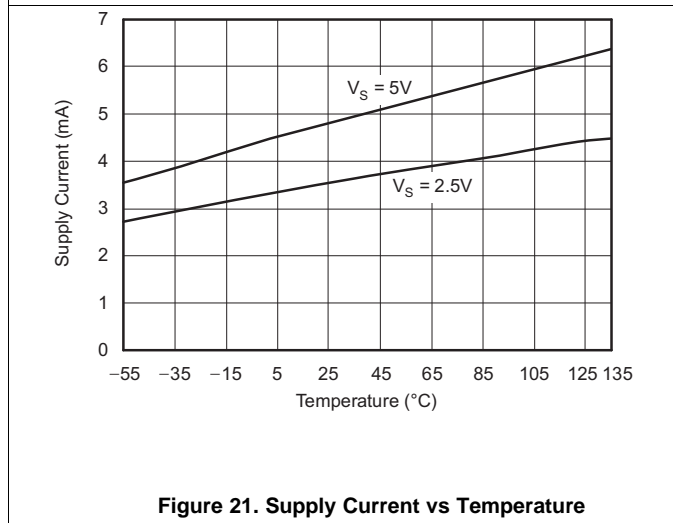

Figure 21. Supply Current vs Temperature

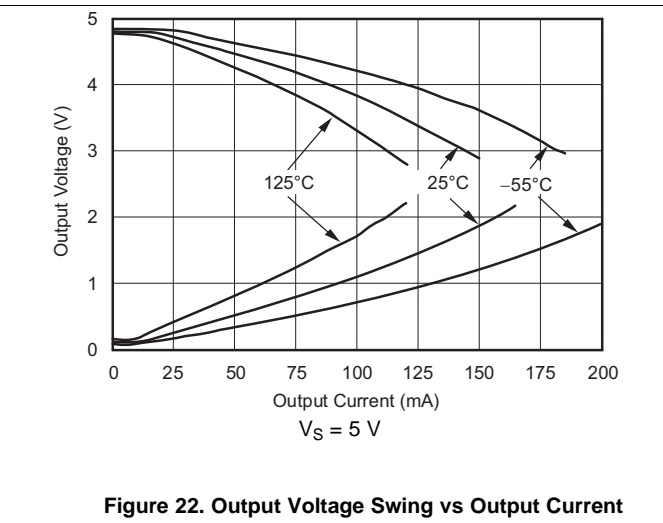

Figure 22. Output Voltage Swing vs Output Current

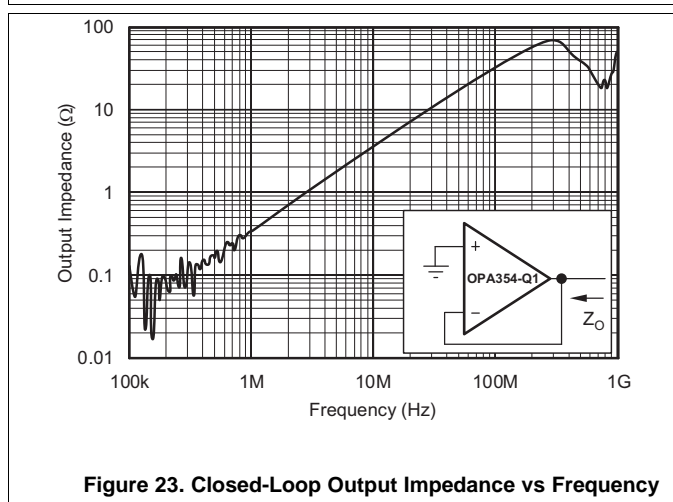

Figure 23. Closed-Loop Output Impedance vs Frequency

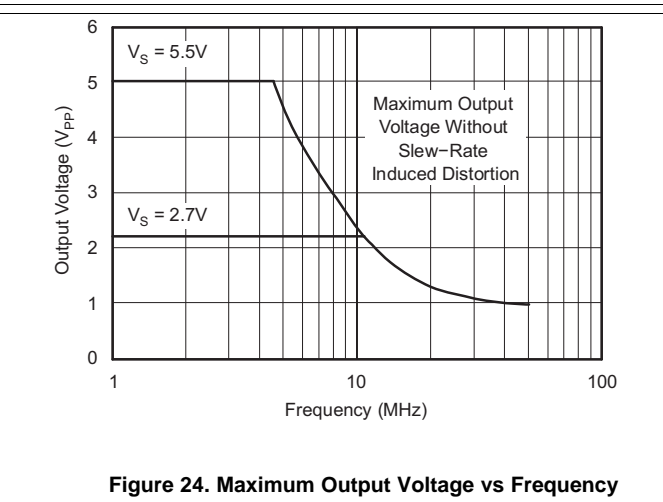

Figure 24. Maximum Output Voltage vs Frequency

Typical Characteristics (continued)

$T_A = 25^\circ\text{C}$, $V_S = 5\text{ V}$, $R_F = 0\ \Omega$, $R_L = 1\text{ k}\Omega$ connected to $V_S / 2$ (unless otherwise noted)

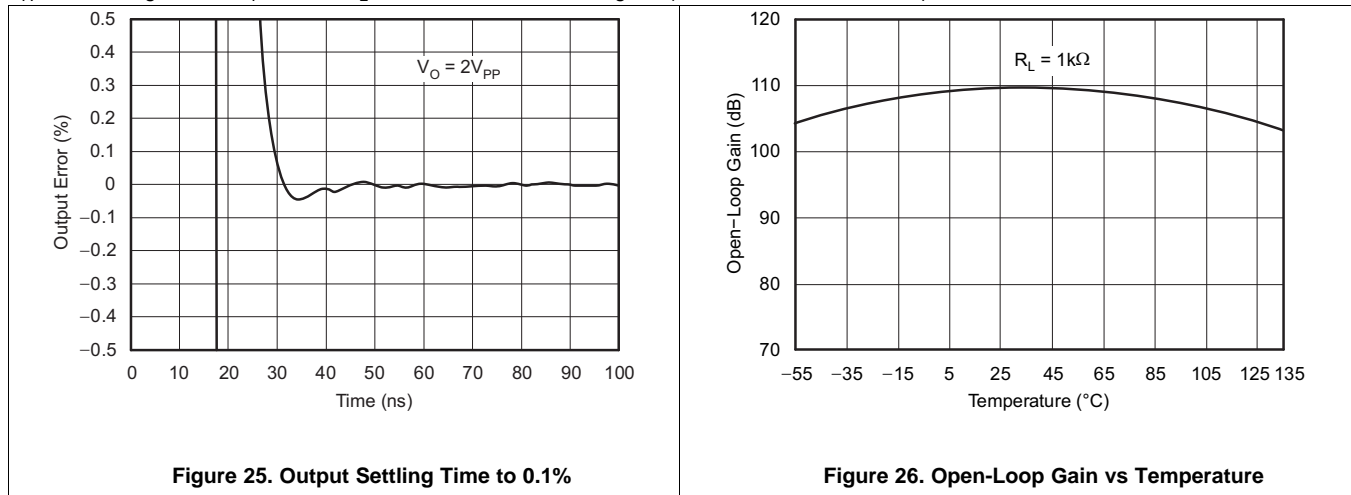

Figure 25. Output Settling Time to 0.1%

Figure 26. Open-Loop Gain vs Temperature

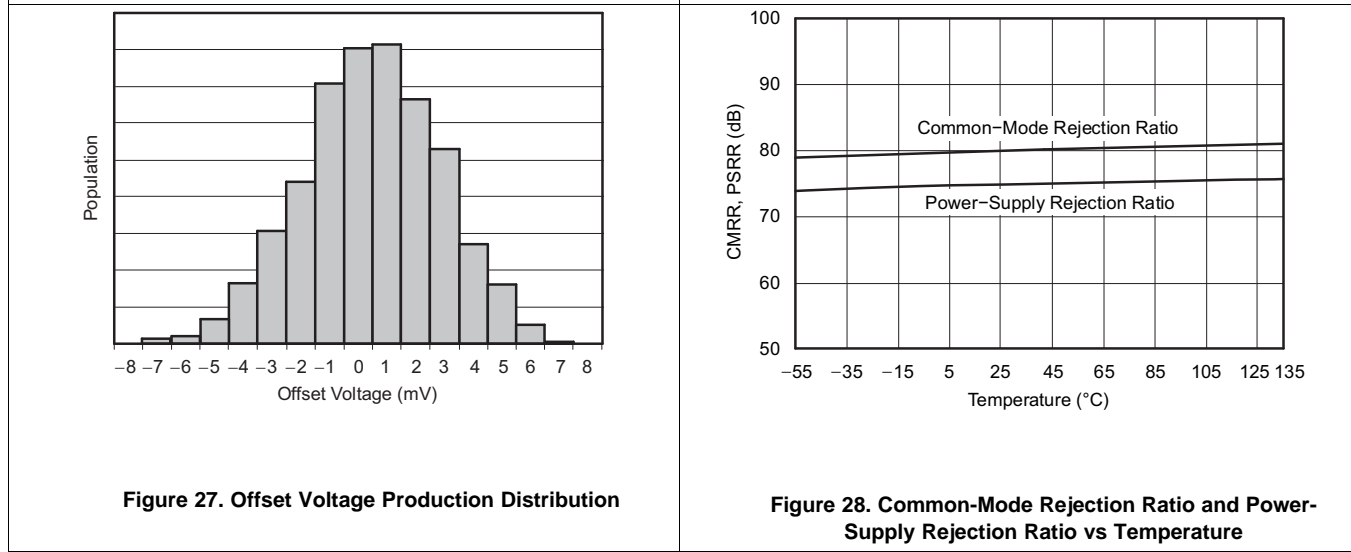

Figure 27. Offset Voltage Production Distribution

Figure 28. Common-Mode Rejection Ratio and Power-Supply Rejection Ratio vs Temperature

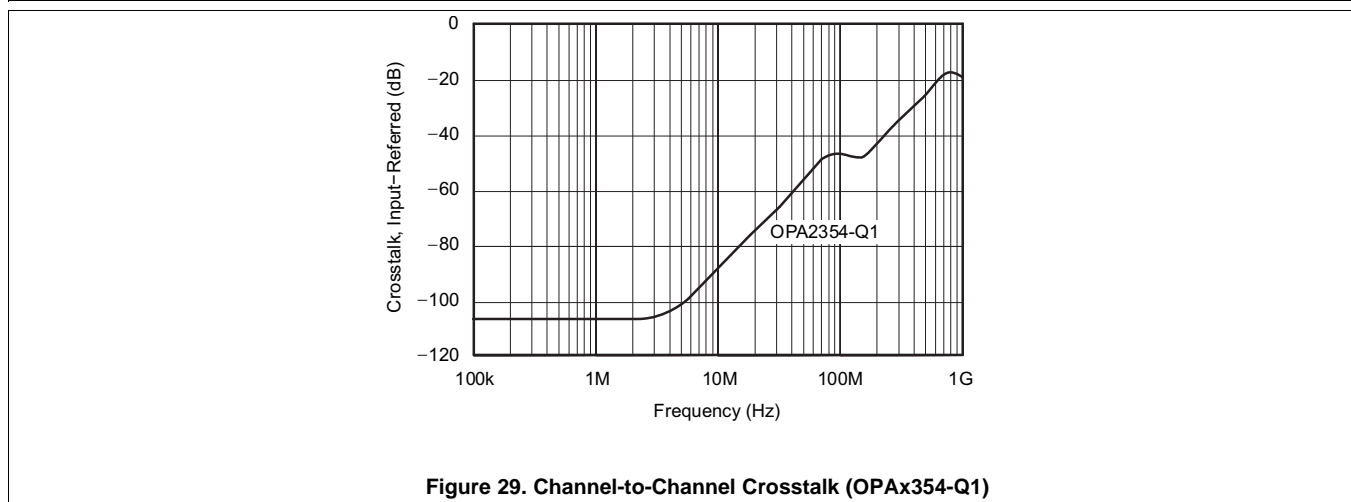

Figure 29. Channel-to-Channel Crosstalk (OPAx354-Q1)

7 Detailed Description

7.1 Overview

The OPAx354-Q1 operational amplifiers are high-speed, 150-V/ μ s, amplifiers making them excellent choices for transimpedance applications. The devices are unity-gain stable and can operate on a single-supply voltage (2.5 V to 5.5 V), or a split-supply voltage (± 1.25 V to ± 2.75 V), making them highly versatile and easy to use. The OPAx354A-Q1 amplifiers are specified from 2.5 V to 5.5 V and over the automotive temperature range of -40°C to $+125^{\circ}\text{C}$.

Table 1. OPAx354-Q1 Related Products

| FEATURES | PRODUCT |
|-----------------------------------------------------|-----------|
| Shutdown Version of OPA354 Family | OPAx357 |
| 200-MHz GBW, Rail-to-Rail Output, CMOS, Shutdown | OPAx355 |
| 200-MHz GBW, Rail-to-Rail Output, CMOS | OPAx356 |
| 38-MHz GBW, Rail-to-Rail Input/Output, CMOS | OPAx350/3 |
| 75-MHz BW, G = 2, Rail-to-Rail Output | OPAx631 |
| 150-MHz BW, G = 2, Rail-to-Rail Output | OPAx634 |
| 100-MHz BW, Differential Input/Output, 3.3-V Supply | THS412x |

7.2 Functional Block Diagram

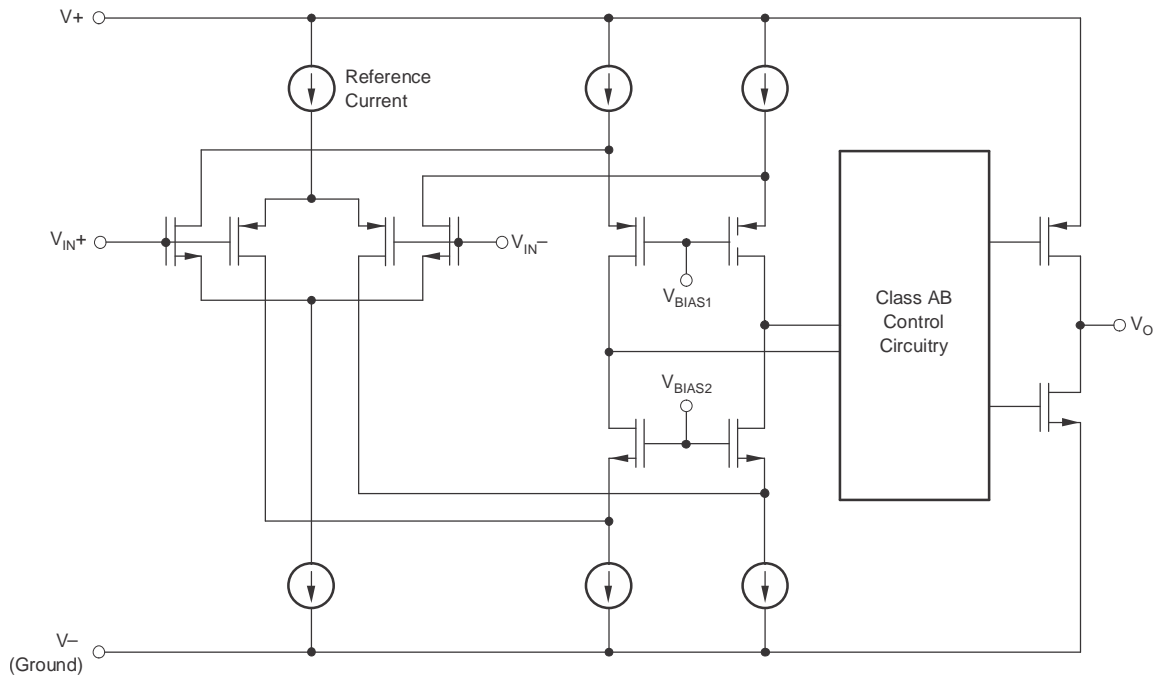

7.3 Feature Description

7.3.1 Operating Voltage

The specifications of the OPAx354-Q1 family of devices apply over a power-supply range of 2.5 V to 5.5 V (± 1.25 V to ± 2.75 V). Supply voltages higher than 7.5 V (absolute maximum) can permanently damage the amplifier.

The [Typical Characteristics](#) section of this data sheet shows the parameters that vary over supply voltage or temperature.

Feature Description (continued)

7.3.2 Rail-to-Rail Input

The specified input common-mode voltage range of the OPAx354-Q1 family of devices extends 100 mV beyond the supply rails. A complementary input stage (an N-channel input differential pair in parallel with a P-channel differential pair) achieves this extension. The N-channel pair is active for input voltages close to the positive rail, typically $(V+) - 1.2\text{ V}$ to 100 mV above the positive supply, while the P-channel pair is on for inputs from 100 mV below the negative supply to approximately $(V+) - 1.2\text{ V}$. A small transition region exists, typically $(V+) - 1.5\text{ V}$ to $(V+) - 0.9\text{ V}$, in which both pairs are on. This 600-mV transition region can vary $\pm 500\text{ mV}$ with process variation. As a result, the transition region (both input stages on) range from $(V+) - 2\text{ V}$ to $(V+) - 1.5\text{ V}$ on the low end, up to $(V+) - 0.9\text{ V}$ to $(V+) - 0.4\text{ V}$ on the high end.

A double-folded cascode adds the signal from the two input pairs and presents a differential signal to the class-AB output stage.

7.3.3 Rail-to-Rail Output

The device uses a class-AB output stage with common-source transistors to achieve rail-to-rail output. For high-impedance loads ($> 200\ \Omega$), the output voltage swing is typically 100 mV from the supply rails. With 10- Ω loads, a user can achieve a useful output swing while maintaining high open-loop gain; see [Figure 20 \(Output Voltage Swing vs Output Current\)](#).

7.3.4 Output Drive

The OPAx354-Q1 output stage supplies a continuous output current of $\pm 100\text{ mA}$ and still provide approximately 2.7-V output swing on a 5-V supply, as shown in [Figure 30](#).

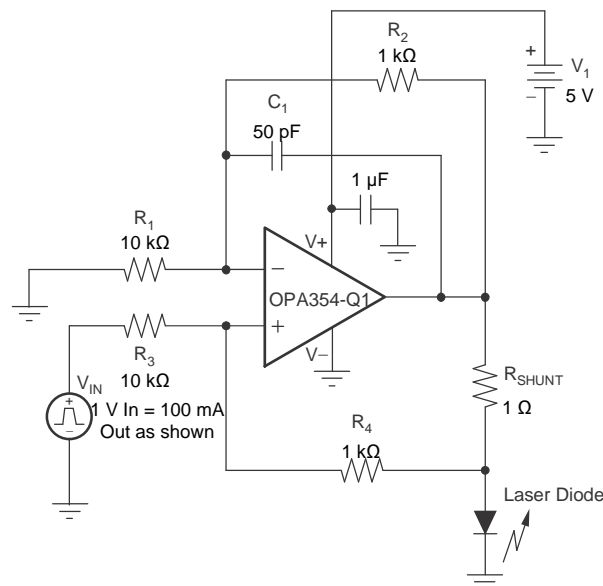

Figure 30. Laser Diode Driver

For maximum reliability, TI does not recommend running a continuous DC current greater than $\pm 100\text{ mA}$; see [Figure 20 \(Output Voltage Swing vs Output Current\)](#). Operate the OPAx354-Q1 family of devices in parallel to supply continuous output currents greater than $\pm 100\text{ mA}$, as shown in [Figure 31](#).

Feature Description (continued)

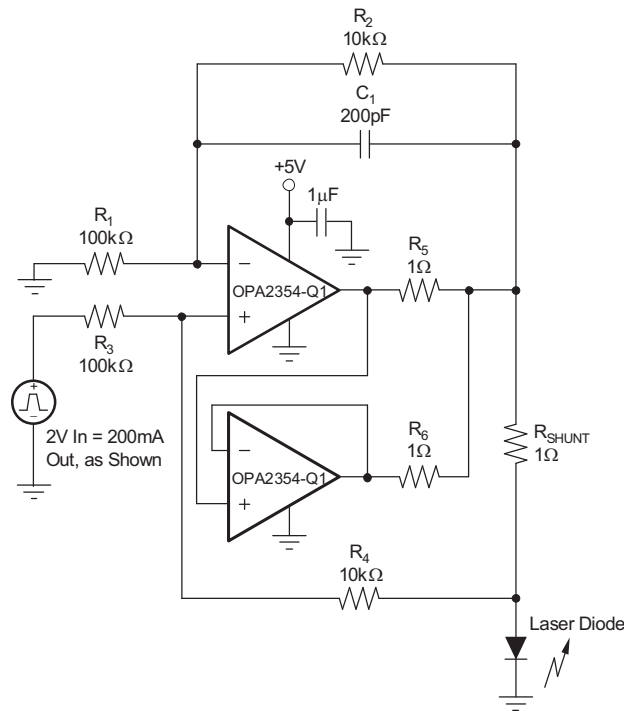

Figure 31. Parallel Operation

The OPAx354-Q1 family of devices provides peak currents up to 200 mA, which correspond to the typical short-circuit current. Therefore, an on-chip thermal shutdown circuit protects the OPAx354-Q1 family of devices from dangerously high junction temperatures. At 160°C, the protection circuit shuts down the amplifier. Normal operation resumes when the junction temperature cools below 140°C.

7.3.5 Video

The OPAx354-Q1 output stage is capable of driving standard back-terminated 75-Ω video cables (see [Figure 32](#)). A back-terminated transmission line does not exhibit a capacitive load to the driver. A properly back-terminated 75-Ω cable does not appear as capacitance; the cable presents a 150-Ω resistive load to the OPAx354-Q1 output.

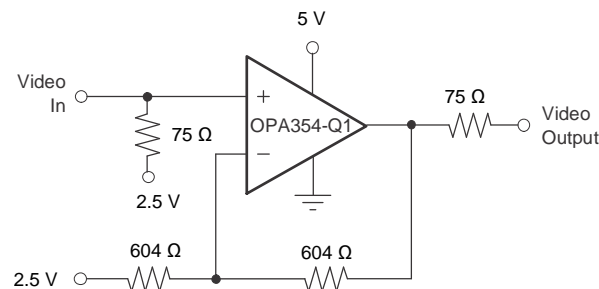
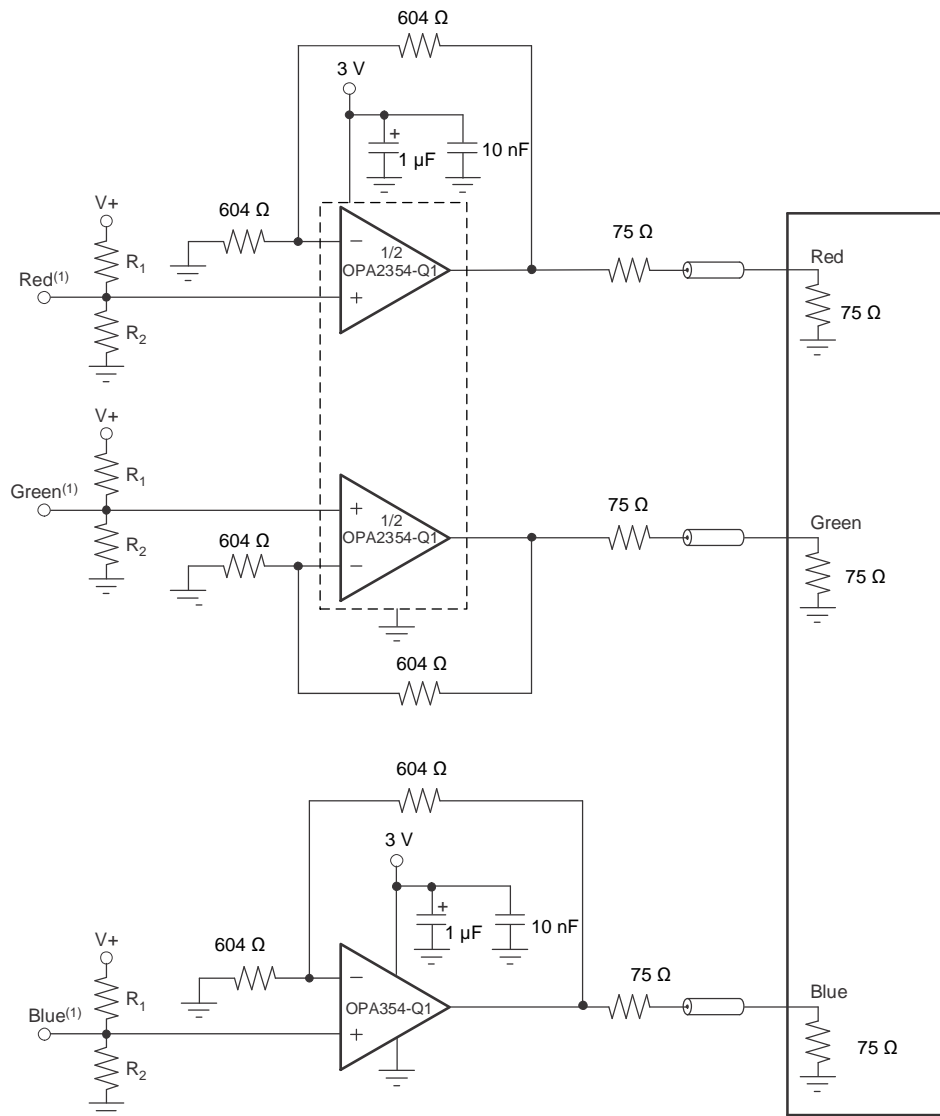

Figure 32. Single-Supply Video Line Driver

This series of amplifiers can be used as an amplifier for RGB graphic signals, which have a voltage of zero at the video black level by offsetting and AC-coupling the signal (see [Figure 33](#)).

Feature Description (continued)

(1) Source video signal offset 300 mV above ground to accommodate op amp swing to ground capability.

Figure 33. RGB Cable Driver

7.3.6 Driving Analog-to-Digital Converters

The OPAx354-Q1 family of op-amps offers a 60-ns settling time to 0.01%, which makes the devices a viable option for driving high- and medium-speed sampling ADCs and reference circuits. The OPAx354-Q1 family of devices provides an effective means of buffering the input capacitance and resulting charge injection of the ADC while providing signal gain. The OPAx354-Q1 family of devices is designed for applications requiring high DC accuracy.

Figure 34 shows the OPAx354-Q1 family of devices driving an ADC. With the OPAx354-Q1 family of devices in an inverting configuration, using a capacitor across the feedback resistor can filter high-frequency noise in the signal.

Feature Description (continued)

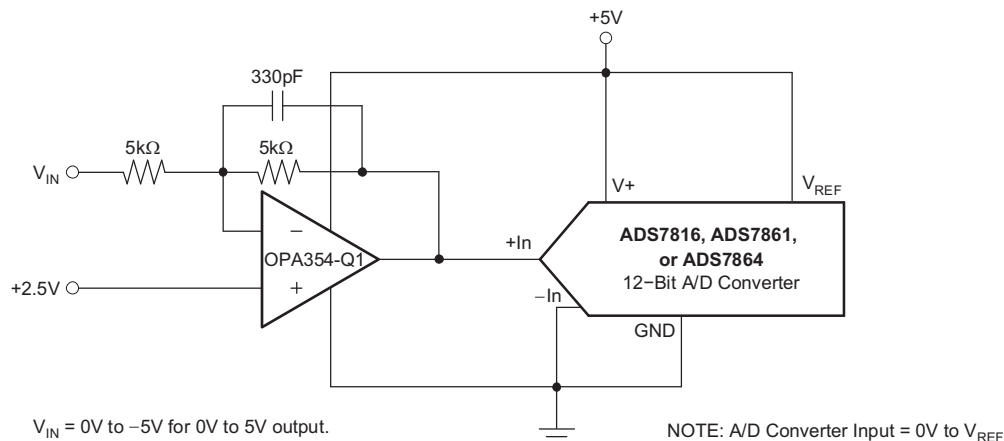

Figure 34. OPA354A-Q1 Inverting Configuration Driving the ADS7816

7.3.7 Capacitive Load and Stability

The OPAx354-Q1 family op amps can drive a wide range of capacitive loads. However, all op-amps under certain conditions can become unstable. Op amp configuration, gain, and load value are a few of the factors to consider when determining stability. An op amp in unity-gain configuration is most susceptible to the effects of capacitive loading. The capacitive load reacts with the output resistance of the op amp, along with any additional load resistance, to create a pole in the small-signal response that degrades the phase margin. For details, see [Figure 15 \(Frequency Response vs Capacitive Load\)](#).

The OPAx354-Q1 topology enhances the ability of the device to drive capacitive loads. In unity gain, these op-amps perform well with large capacitive loads. For details see [Figure 14, Recommended \$R_S\$ vs Capacitive Load](#), and [Figure 15, Frequency Response vs Capacitive Load](#).

Insert a 10- Ω to 20- Ω resistor in series with the output to improve capacitive load drive in the unity-gain configuration, as shown in [Figure 35](#). This configuration significantly reduces ringing with large capacitive loads; see [Figure 15 \(Frequency Response vs Capacitive Load\)](#). However, if a resistive load is in parallel with the capacitive load, R_S creates a voltage divider. This configuration introduces a DC error at the output and slightly reduces output swing. This error may be insignificant. For example, if $R_L = 10 \text{ k}\Omega$ and $R_S = 20 \text{ }\Omega$, the error at the output is approximately 0.2%.

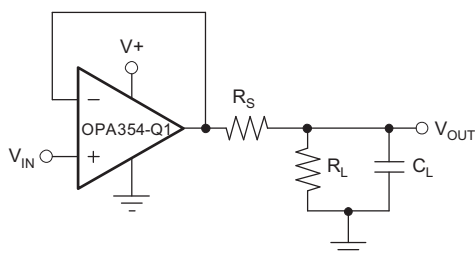

Figure 35. Series Resistor in Unity-Gain Configuration Improves Capacitive Load Drive

7.3.8 Wideband Transimpedance Amplifier

Wide bandwidth, low-input bias current, and low input voltage and current noise make the OPAx354-Q1 family of devices is designed as a wideband photodiode transimpedance amplifier for low-voltage single-supply applications. Low-voltage noise is important because photodiode capacitance causes the effective noise gain of the circuit to increase at high frequency.

Feature Description (continued)

The key elements to a transimpedance design, as shown in [Figure 36](#), are the expected diode capacitance [including the parasitic input common-mode and differential-mode input capacitance (2 + 2) pF for the OPAx354-Q1], the desired transimpedance gain (R_F), and the gain-bandwidth product (GBW) for the OPAx354-Q1 family of devices (100 MHz). With these three variables set, the feedback capacitor value (C_F) is set to control the frequency response.

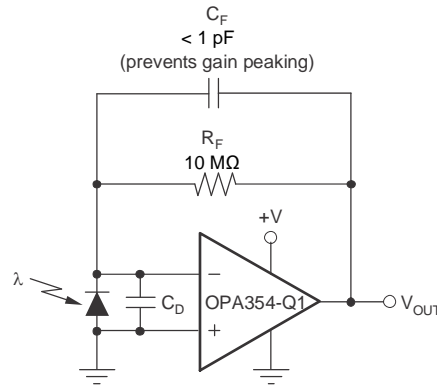

Figure 36. Transimpedance Amplifier

To achieve a maximally flat second-order Butterworth frequency response, set the feedback pole as shown in [Equation 1](#).

$$\frac{1}{2\pi R_F C_F} = \sqrt{\frac{\text{GBP}}{4\pi R_F C_D}} \quad (1)$$

Typical surface-mount resistors have a parasitic capacitance of approximately 0.2 pF that required deduction from the calculated feedback capacitance value.

Use [Equation 2](#) to calculate the bandwidth.

$$f_{-3\text{dB}} = \sqrt{\frac{\text{GBP}}{2\pi R_F C_D}} \text{ Hz} \quad (2)$$

For even higher transimpedance bandwidth, use the high-speed CMOS OPA355-Q1 (200-MHz GBW) or the OPA655-Q1 (400-MHz GBW).

7.4 Device Functional Modes

The OPAx354-Q1 family of devices is powered on when the supply is connected. The devices operates as a single-supply operational amplifier or dual-supply amplifier depending on the application. The devices are used with asymmetrical supplies as long as the differential voltage (V_- to V_+) is at least 1.8 V and no greater than 5.5 V (example: V_- set to -3.5 V and V_+ set to 1.5 V).

8 Application and Implementation

NOTE

Information in the following applications sections is not part of the TI component specification, and TI does not warrant its accuracy or completeness. TI's customers are responsible for determining suitability of components for their purposes. Customers should validate and test their design implementation to confirm system functionality.

8.1 Application Information

The OPAx354-Q1 family of devices is a CMOS, rail-to-rail I/O, high-speed, voltage-feedback operational amplifier designed for video, high-speed, and other applications. The OPAx354-Q1 family of devices is available as a single, dual, or quad op-amp.

The amplifier features a 100-MHz gain bandwidth, and 150 V/ μ s slew rate, but the device is unity-gain stable and operates as a 1-V/V voltage follower.

8.2 Typical Applications

8.2.1 Transimpedance Amplifier

Wide gain bandwidth, low input bias current, low input voltage, and current noise make the OPAx354-Q1 family of devices a preferred wideband photodiode transimpedance amplifier. Low-voltage noise is important because photodiode capacitance causes the effective noise gain of the circuit to increase at high frequency.

The key elements to a transimpedance design, as shown in [Figure 37](#), are the expected diode capacitance ($C_{(D)}$), which must include the parasitic input common-mode and differential-mode input capacitance (4 pF + 5 pF); the desired transimpedance gain ($R_{(FB)}$); and the gain-bandwidth (GBW) for the OPAx354-Q1 family of devices (20 MHz). With these three variables set, the feedback capacitor value ($C_{(FB)}$) is set to control the frequency response. $C_{(FB)}$ includes the stray capacitance of $R_{(FB)}$, which is 0.2 pF for a typical surface-mount resistor.

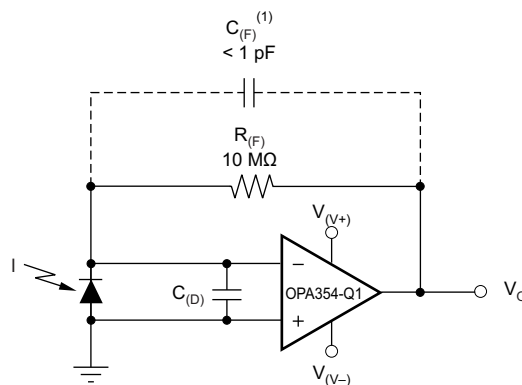

(1) $C_{(FB)}$ is optional to prevent gain peaking. $C_{(FB)}$ includes the stray capacitance of $R_{(FB)}$.

Figure 37. Dual-Supply Transimpedance Amplifier

8.2.1.1 Design Requirements

| PARAMETER | VALUE |
|---------------------------|--------|
| Supply voltage $V_{(V+)}$ | 2.5 V |
| Supply voltage $V_{(V-)}$ | -2.5 V |

8.2.1.2 Detailed Design Procedure

To achieve a maximally-flat, second-order Butterworth frequency response, the feedback pole must be set to:

$$\frac{1}{2 \times \pi \times R_{(FB)} \times C_{(FB)}} = \sqrt{\frac{GBW}{4 \times \pi \times R_{(FB)} \times C_{(D)}}} \quad (3)$$

Use [Equation 4](#) to calculate the bandwidth.

$$f_{(-3 \text{ dB})} = \sqrt{\frac{GBW}{2 \times \pi \times R_{(FB)} \times C_{(D)}}} \quad (4)$$

For other transimpedance bandwidths, consider the high-speed CMOS [OPA380](#) (90-MHz GBW), [OPA354](#) (100-MHz GBW), [OPA300](#) (180-MHz GBW), [OPA355](#) (200-MHz GBW), or [OPA656](#) and [OPA657](#) (400-MHz GBW).

For single-supply applications, the +INx input can be biased with a positive DC voltage to allow the output to reach true zero when the photodiode is not exposed to any light, and respond without the added delay that results from coming out of the negative rail; this configuration is shown in [Figure 38](#). This bias voltage appears across the photodiode, providing a reverse bias for faster operation.

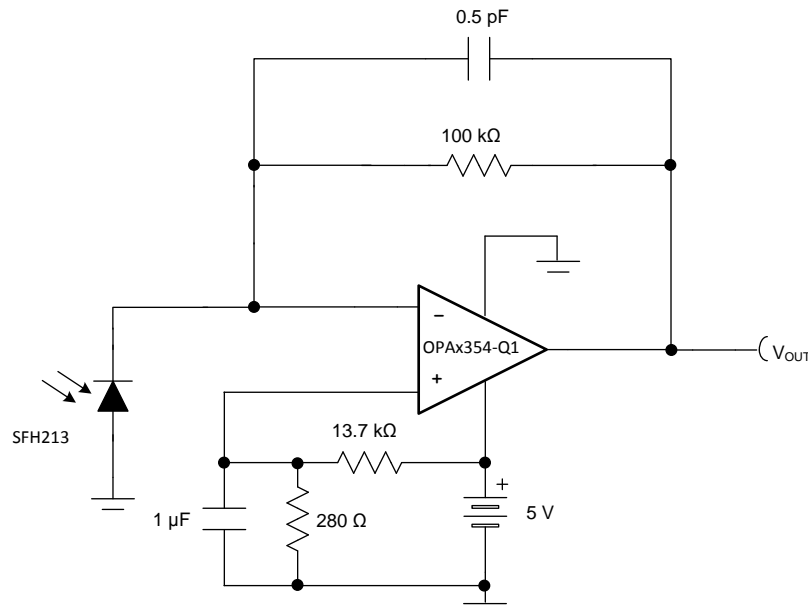

Figure 38. Single-Supply Transimpedance Amplifier

For additional information, see the [Compensate Transimpedance Amplifiers Intuitively](#) application bulletin.

8.2.1.2.1 Optimizing The Transimpedance Circuit

To achieve the best performance, components must be selected according to the following guidelines:

1. For lowest noise, select $R_{(FB)}$ to create the total required gain. Using a lower value for $R_{(FB)}$ and adding gain after the transimpedance amplifier generally produces poorer noise performance. The noise produced by $R_{(FB)}$ increases with the square-root of $R_{(FB)}$, whereas the signal increases linearly. Therefore, signal-to-noise ratio improves when all the required gain is placed in the transimpedance stage.
2. Minimize photodiode capacitance and stray capacitance at the summing junction (inverting input). This capacitance causes the voltage noise of the op amp to be amplified (increasing amplification at high frequency). Using a low-noise voltage source to reverse-bias a photodiode can significantly reduce the capacitance. Smaller photodiodes have lower capacitance. Use optics to concentrate light on a small photodiode.
3. Noise increases with increased bandwidth. Limit the circuit bandwidth to only that required. Use a capacitor across the $R_{(FB)}$ to limit bandwidth, even if not required for stability.
4. Circuit board leakage can degrade the performance of an otherwise well-designed amplifier. Clean the circuit

board carefully. A circuit board guard trace that encircles the summing junction and is driven at the same voltage can help control leakage.

For additional information, see the [Noise Analysis of FET Transimpedance Amplifiers](#), and [Noise Analysis for High-Speed Op Amps](#) application bulletins.

8.2.1.3 Application Curve

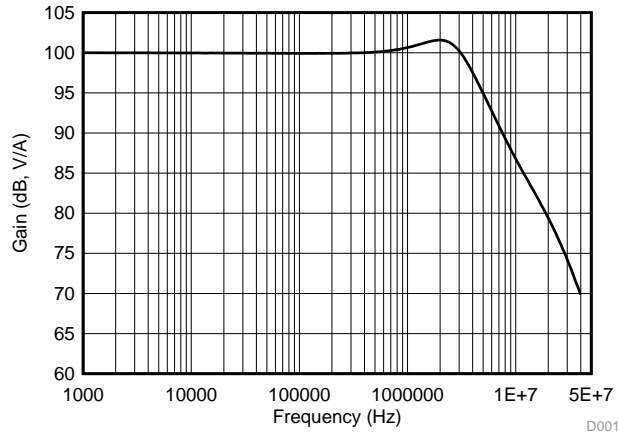

-3 dB bandwidth is 4.56 MHz

Figure 39. AC Transfer Function

8.2.2 High-Impedance Sensor Interface

Many sensors have high source impedances that may range up to 10 MΩ, or even higher. The output signal of sensors often must be amplified or otherwise conditioned by an amplifier. The input bias current of this amplifier can load the sensor output and cause a voltage drop across the source resistance, as shown in Figure 40, where $(V_{(+INx)} = V_S - I_{(BIAS)} \times R_{(S)})$. The last term, $I_{(BIAS)} \times R_{(S)}$, shows the voltage drop across $R_{(S)}$. To prevent errors introduced to the system as a result of this voltage, use an op amp with low input bias current and high-impedance sensors. This low current keeps the error contribution by $I_{(BIAS)} \times R_{(S)}$ less than the input voltage noise of the amplifier, so that the amplifier does not become the dominant noise factor. The OPax354-Q1 family of devices series of op amps feature low input bias current (typically 200 fA), and are therefore designed for such applications.

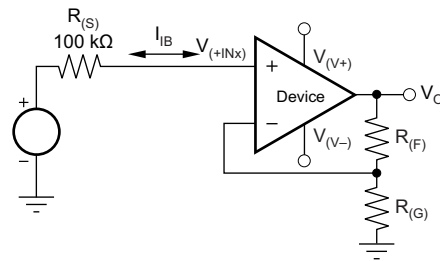
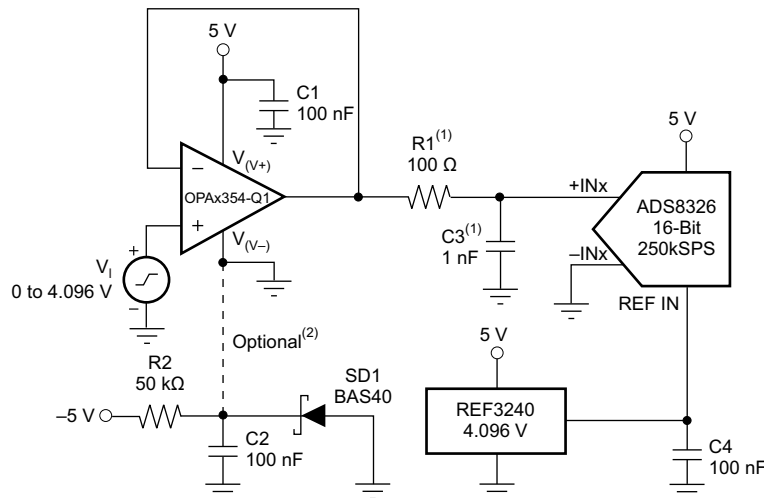

Figure 40. Noise as a Result of $I_{(BIAS)}$

8.2.3 Driving ADCs

The OPAx354-Q1 op amps are designed for driving sampling analog-to-digital converters (ADCs) with sampling speeds up to 1 MSPS. The zero-crossover distortion input stage topology allows the OPAx354-Q1 family of devices to drive ADCs without degradation of differential linearity and THD.

The OPAx354-Q1 family of devices can be used to buffer the ADC switched input capacitance and resulting charge injection while providing signal gain. [Figure 41](#) shows the OPAx354-Q1 family of devices configured to drive the [ADS8326](#).



(1) Suggested value; may require adjustment based on specific application.

(2) Single-supply applications lose a small number of ADC codes near ground as a result of op amp output swing limitation. If a negative power supply is available, this simple circuit creates a -0.3-V supply to allow output swing to true ground potential.

Figure 41. Driving the ADS8326

8.2.4 Active Filter

The OPAx354-Q1 family of devices is designed for active filter applications that require a wide bandwidth, fast slew rate, low-noise, single-supply operational amplifier. [Figure 42](#) shows a 500 kHz, second-order, low-pass filter using the multiple-feedback (MFB) topology. The components are selected to provide a maximally-flat Butterworth response. Beyond the cutoff frequency, roll-off is -40 dB/dec . The Butterworth response is designed for applications requiring predictable gain characteristics, such as the anti-aliasing filter used in front of an ADC.

One point to observe when considering the MFB filter is that the output is inverted relative to the input. If this inversion is not required, or not desired, a noninverting output can be achieved through one of the following options:

1. Adding an inverting amplifier
2. Adding an additional second-order MFB stage
3. Using a noninverting filter topology, such as the Sallen-Key (see [Figure 43](#)).

MFB and Sallen-Key, low-pass and high-pass filter synthesis is accomplished using TI's [FilterPro™](#) program. This software is available as a free download on www.ti.com.

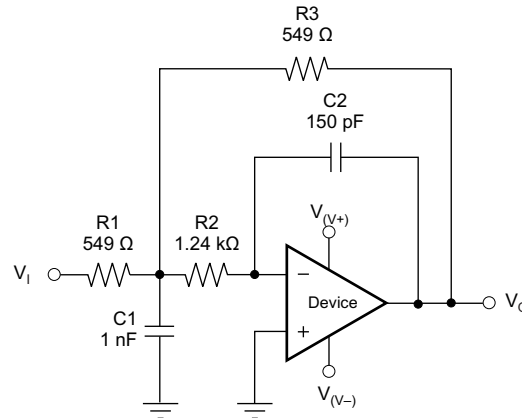

Figure 42. Second-Order Butterworth 500-kHz Low-Pass Filter

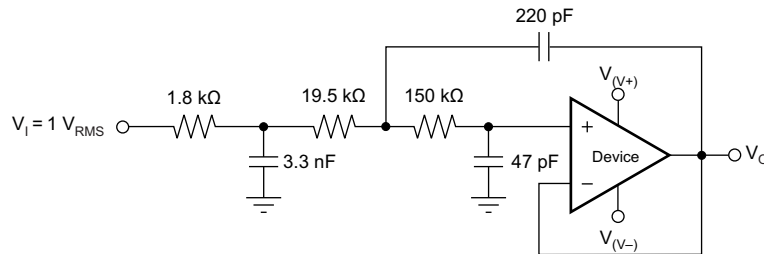

Figure 43. OPAx354-Q1 Configured as a Three-Pole, 20-kHz, Sallen-Key Filter

9 Power Supply Recommendations

The OPAx354-Q1 family of devices is specified for operation from 2.5 to 5.5 V (± 1.25 to ± 2.75 V); many specifications apply from -40°C to $+125^{\circ}\text{C}$. Parameters that can exhibit significant variance with regard to operating voltage or temperature are shown in the [Typical Characteristics](#) section.

CAUTION

Supply voltages larger than 7.5 V can permanently damage the device (see the [Absolute Maximum Ratings](#) table).

Place 0.1- μF bypass capacitors close to the power-supply pins to reduce errors coupling in from noisy or high-impedance power supplies. For more detailed information on bypass capacitor placement, see the [Layout Guidelines](#) section.

9.1 Power Dissipation

Power dissipation depends on power-supply voltage, signal and load conditions. With dc signals, power dissipation is equal to the product of output current times the voltage across the conducting output transistor ($V_S - V_O$). Minimize power dissipation by using the lowest possible power-supply voltage required to ensure the required output voltage swing.

For resistive loads, the maximum power dissipation occurs at a DC output voltage of one-half the power-supply voltage. Dissipation with AC signals is lower. The [Power Amplifier Stress and Power Handling Limitations](#) application bulletin from www.ti.com explains how to calculate or measure power dissipation with unusual signals and loads.

Any tendency to activate the thermal protection circuit indicates excessive power dissipation or an inadequate heat sink. For reliable operation, limit junction temperature to 150°C, maximum. To estimate the margin of safety in a complete design, increase the ambient temperature to trigger the thermal protection at 160°C. The thermal protection must trigger more than 35°C above the maximum expected ambient condition of the application.

10 Layout

10.1 Layout Guidelines

Use good high-frequency printed circuit board (PCB) layout techniques for the OPAx354-Q1 family of devices. Generous use of ground planes, short and direct signal traces, and a suitable bypass capacitor located at the V+ pin ensure clean, stable operation. Large areas of copper provide a means of dissipating heat that is generated in normal operation. Sockets are not recommended for use with any high-speed amplifier. A 10-nF ceramic bypass capacitor is the minimum recommended value; adding a 1- μ F or larger tantalum capacitor in parallel can be beneficial when driving a low-resistance load. Providing adequate bypass capacitance is essential to achieving very low harmonic and intermodulation distortion.

For best operational performance of the device, use good PCB layout practices, including:

- Noise can propagate into analog circuitry through the power pins of the circuit as a whole and the operational amplifier. Bypass capacitors are used to reduce the coupled noise by providing low-impedance power sources local to the analog circuitry.
 - Connect low-ESR, 0.1- μ F ceramic bypass capacitors between each supply pin and ground, placed as close to the device as possible. A single bypass capacitor from V+ to ground is applicable for single-supply applications.
- Separate grounding for analog and digital portions of the circuitry is one of the simplest and most effective methods of noise suppression. One or more layers on multilayer PCBs are usually devoted to ground planes. A ground plane helps distribute heat and reduces EMI noise pickup. Make sure to physically separate digital and analog grounds, paying attention to the flow of the ground current. For more detailed information, see [Circuit Board Layout Techniques](#).
- To reduce parasitic coupling, run the input traces as far away from the supply or output traces as possible. If these traces cannot be kept separate, crossing the sensitive trace perpendicularly is much better than crossing in parallel with the noisy trace.
- Place the external components as close to the device as possible. Keeping RF and RG close to the inverting input minimizes parasitic capacitance, as shown in [Figure 44](#).
- Keep the length of input traces as short as possible. Always remember that the input traces are the most sensitive part of the circuit.
- Consider a driven, low-impedance guard ring around the critical traces. A guard ring can significantly reduce leakage currents from nearby traces that are at different potentials.

10.2 Layout Example

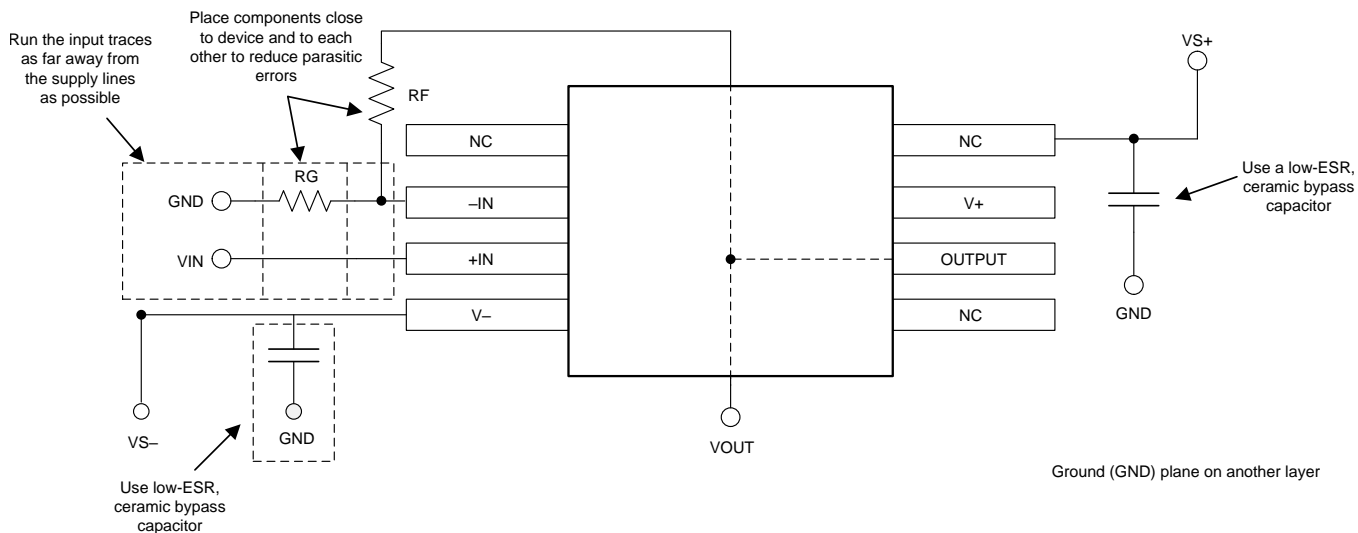

Figure 44. Operational Amplifier Board Layout for Noninverting Configuration

11 Device and Documentation Support

11.1 Documentation Support

11.1.1 Related Documentation

For related documentation see the following:

- Texas Instruments, [ADS8326 16-Bit, High-Speed, 2.7V to 5.5V microPower Sampling Analog-to-Digital Converter](#)
- Texas Instruments, [Circuit Board Layout Techniques](#)
- Texas Instruments, [Compensate Transimpedance Amplifiers Intuitively](#)
- Texas Instruments, [FilterPro™ User's Guide](#)
- Texas Instruments, [Noise Analysis of FET Transimpedance Amplifiers](#)
- Texas Instruments, [Noise Analysis for High-Speed Op Amps](#)
- Texas Instruments, [OPA380 and OPA2380 Precision, High-Speed Transimpedance Amplifier](#)
- Texas Instruments, [OPA354, OPA2354, and OPA4354 250MHz, Rail-to-Rail I/O, CMOS Operational Amplifiers](#)
- Texas Instruments, [OPA355, OPA2355, and OPA3355 200MHz, CMOS Operational Amplifier With Shutdown](#)
- Texas Instruments, [OPA656 Wideband, Unity-Gain Stable, FET-Input Operational Amplifier](#)
- Texas Instruments, [Power Amplifier Stress and Power Handling Limitations](#)

11.2 Related Links

The table below lists quick access links. Categories include technical documents, support and community resources, tools and software, and quick access to sample or buy.

Table 2. Related Links

| PARTS | PRODUCT FOLDER | ORDER NOW | TECHNICAL DOCUMENTS | TOOLS & SOFTWARE | SUPPORT & COMMUNITY |
|-------------|----------------------------|----------------------------|----------------------------|----------------------------|----------------------------|
| OPA354A-Q1 | Click here | Click here | Click here | Click here | Click here |
| OPA2354A-Q1 | Click here | Click here | Click here | Click here | Click here |
| OPA4354-Q1 | Click here | Click here | Click here | Click here | Click here |

11.3 Receiving Notification of Documentation Updates

To receive notification of documentation updates, navigate to the device product folder on ti.com. In the upper right corner, click on *Alert me* to register and receive a weekly digest of any product information that has changed. For change details, review the revision history included in any revised document.

11.4 Community Resources

The following links connect to TI community resources. Linked contents are provided "AS IS" by the respective contributors. They do not constitute TI specifications and do not necessarily reflect TI's views; see TI's [Terms of Use](#).

TI E2E™ Online Community *TI's Engineer-to-Engineer (E2E) Community*. Created to foster collaboration among engineers. At e2e.ti.com, you can ask questions, share knowledge, explore ideas and help solve problems with fellow engineers.

Design Support *TI's Design Support* Quickly find helpful E2E forums along with design support tools and contact information for technical support.

11.5 Trademarks

E2E is a trademark of Texas Instruments.

FilterPro is a trademark of Texas Instruments Incorporated.

All other trademarks are the property of their respective owners.

11.6 Electrostatic Discharge Caution



These devices have limited built-in ESD protection. The leads should be shorted together or the device placed in conductive foam during storage or handling to prevent electrostatic damage to the MOS gates.

11.7 Glossary

[SLYZ022](#) — *TI Glossary*.

This glossary lists and explains terms, acronyms, and definitions.

12 Mechanical, Packaging, and Orderable Information

The following pages include mechanical, packaging, and orderable information. This information is the most current data available for the designated devices. This data is subject to change without notice and revision of this document. For browser-based versions of this data sheet, refer to the left-hand navigation.

PACKAGING INFORMATION

| Orderable Device | Status (1) | Package Type | Package Drawing | Pins | Package Qty | Eco Plan (2) | Lead/Ball Finish (6) | MSL Peak Temp (3) | Op Temp (°C) | Device Marking (4/5) | Samples |
|------------------|---------------|--------------|-----------------|------|-------------|-------------------------|-------------------------|----------------------|--------------|-------------------------|-------------------------|
| OPA2354AQDGKRQ1 | ACTIVE | VSSOP | DGK | 8 | 2500 | Green (RoHS & no Sb/Br) | CU NIPDAU CU NIPDAUAG | Level-2-260C-1 YEAR | -40 to 125 | OSLQ | Samples |
| OPA354AQDBVRQ1 | ACTIVE | SOT-23 | DBV | 5 | 3000 | Green (RoHS & no Sb/Br) | CU NIPDAU | Level-2-260C-1 YEAR | -40 to 125 | OSFQ | Samples |
| OPA4354AQPWRQ1 | ACTIVE | TSSOP | PW | 14 | 2000 | Green (RoHS & no Sb/Br) | CU NIPDAU | Level-3-260C-168 HR | -40 to 125 | 4354Q1 | Samples |

(1) The marketing status values are defined as follows:

ACTIVE: Product device recommended for new designs.

LIFEBUY: TI has announced that the device will be discontinued, and a lifetime-buy period is in effect.

NRND: Not recommended for new designs. Device is in production to support existing customers, but TI does not recommend using this part in a new design.

PREVIEW: Device has been announced but is not in production. Samples may or may not be available.

OBsolete: TI has discontinued the production of the device.

(2) **RoHS:** TI defines "RoHS" to mean semiconductor products that are compliant with the current EU RoHS requirements for all 10 RoHS substances, including the requirement that RoHS substance do not exceed 0.1% by weight in homogeneous materials. Where designed to be soldered at high temperatures, "RoHS" products are suitable for use in specified lead-free processes. TI may reference these types of products as "Pb-Free".

RoHS Exempt: TI defines "RoHS Exempt" to mean products that contain lead but are compliant with EU RoHS pursuant to a specific EU RoHS exemption.

Green: TI defines "Green" to mean the content of Chlorine (Cl) and Bromine (Br) based flame retardants meet JS709B low halogen requirements of <=1000ppm threshold. Antimony trioxide based flame retardants must also meet the <=1000ppm threshold requirement.

(3) MSL, Peak Temp. - The Moisture Sensitivity Level rating according to the JEDEC industry standard classifications, and peak solder temperature.

(4) There may be additional marking, which relates to the logo, the lot trace code information, or the environmental category on the device.

(5) Multiple Device Markings will be inside parentheses. Only one Device Marking contained in parentheses and separated by a "-" will appear on a device. If a line is indented then it is a continuation of the previous line and the two combined represent the entire Device Marking for that device.

(6) Lead/Ball Finish - Orderable Devices may have multiple material finish options. Finish options are separated by a vertical ruled line. Lead/Ball Finish values may wrap to two lines if the finish value exceeds the maximum column width.

Important Information and Disclaimer:The information provided on this page represents TI's knowledge and belief as of the date that it is provided. TI bases its knowledge and belief on information provided by third parties, and makes no representation or warranty as to the accuracy of such information. Efforts are underway to better integrate information from third parties. TI has taken and continues to take reasonable steps to provide representative and accurate information but may not have conducted destructive testing or chemical analysis on incoming materials and chemicals. TI and TI suppliers consider certain information to be proprietary, and thus CAS numbers and other limited information may not be available for release.

In no event shall TI's liability arising out of such information exceed the total purchase price of the TI part(s) at issue in this document sold by TI to Customer on an annual basis.

OTHER QUALIFIED VERSIONS OF OPA4354-Q1 :

- Catalog: [OPA4354](#)

NOTE: Qualified Version Definitions:

- Catalog - TI's standard catalog product

TAPE AND REEL INFORMATION

QUADRANT ASSIGNMENTS FOR PIN 1 ORIENTATION IN TAPE

*All dimensions are nominal

| Device | Package Type | Package Drawing | Pins | SPQ | Reel Diameter (mm) | Reel Width W1 (mm) | A0 (mm) | B0 (mm) | K0 (mm) | P1 (mm) | W (mm) | Pin1 Quadrant |
|-----------------|--------------|-----------------|------|------|--------------------|--------------------|---------|---------|---------|---------|--------|---------------|
| OPA2354AQDGKRQ1 | VSSOP | DGK | 8 | 2500 | 330.0 | 12.4 | 5.3 | 3.4 | 1.4 | 8.0 | 12.0 | Q1 |
| OPA354AQDBVRQ1 | SOT-23 | DBV | 5 | 3000 | 179.0 | 8.4 | 3.2 | 3.2 | 1.4 | 4.0 | 8.0 | Q3 |
| OPA4354AQPWRQ1 | TSSOP | PW | 14 | 2000 | 330.0 | 12.4 | 6.9 | 5.6 | 1.6 | 8.0 | 12.0 | Q1 |

TAPE AND REEL BOX DIMENSIONS

*All dimensions are nominal



| Device | Package Type | Package Drawing | Pins | SPQ | Length (mm) | Width (mm) | Height (mm) |
|-----------------|--------------|-----------------|------|------|-------------|------------|-------------|
| OPA2354AQDGKRQ1 | VSSOP | DGK | 8 | 2500 | 367.0 | 367.0 | 35.0 |
| OPA354AQDBVRQ1 | SOT-23 | DBV | 5 | 3000 | 195.0 | 200.0 | 45.0 |
| OPA4354AQPWRQ1 | TSSOP | PW | 14 | 2000 | 367.0 | 367.0 | 35.0 |

PW (R-PDSO-G14)

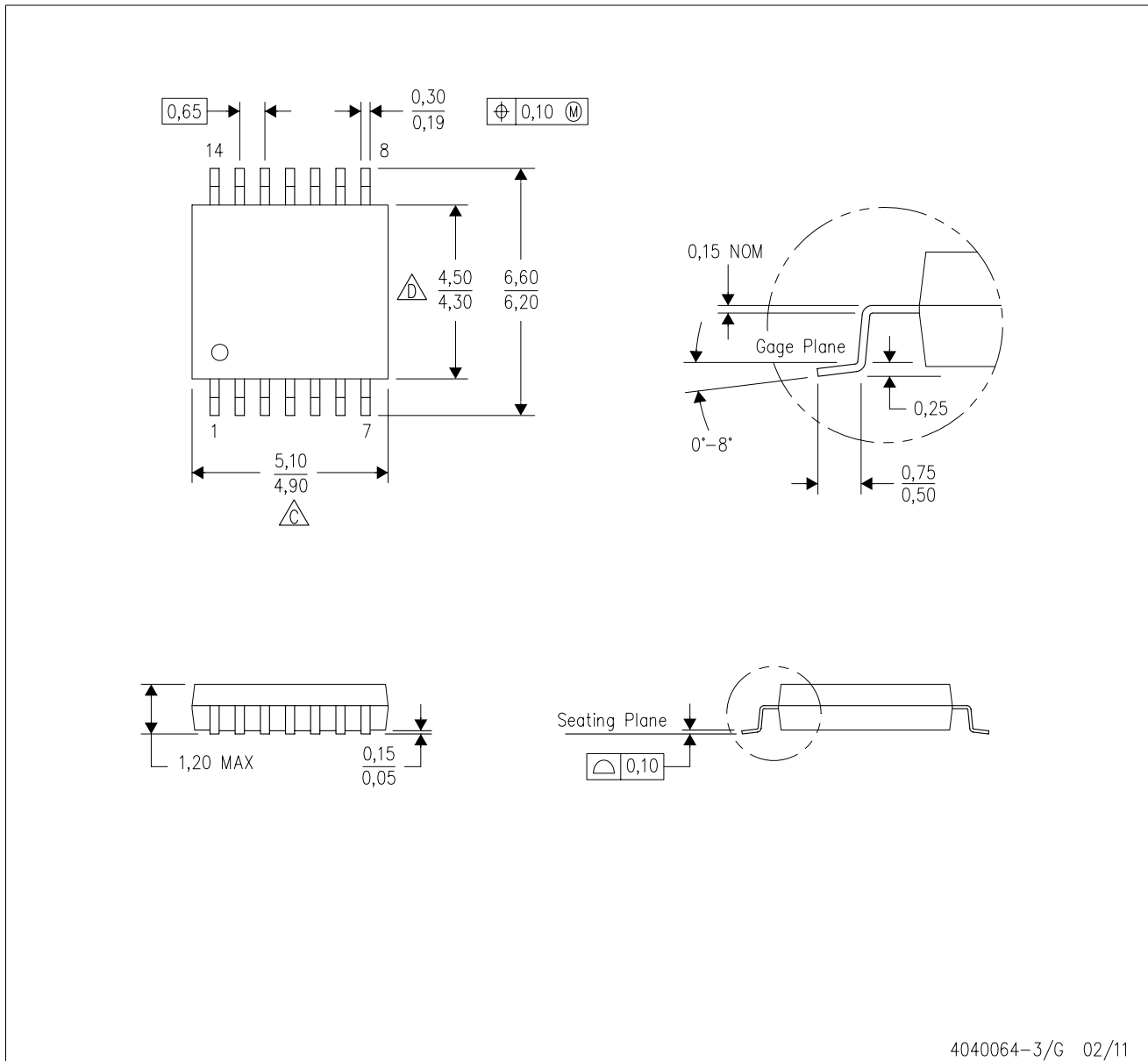
PLASTIC SMALL OUTLINE



4040064-3/G 02/11

- NOTES:
- A. All linear dimensions are in millimeters. Dimensioning and tolerancing per ASME Y14.5M-1994.
 - B. This drawing is subject to change without notice.
 -  C. Body length does not include mold flash, protrusions, or gate burrs. Mold flash, protrusions, or gate burrs shall not exceed 0,15 each side.
 -  D. Body width does not include interlead flash. Interlead flash shall not exceed 0,25 each side.
 - E. Falls within JEDEC MO-153

PW (R-PDSO-G14)

PLASTIC SMALL OUTLINE



4211284-2/G 08/15

- NOTES:
- All linear dimensions are in millimeters.
 - This drawing is subject to change without notice.
 - Publication IPC-7351 is recommended for alternate designs.
 - Laser cutting apertures with trapezoidal walls and also rounding corners will offer better paste release. Customers should contact their board assembly site for stencil design recommendations. Refer to IPC-7525 for other stencil recommendations.
 - Customers should contact their board fabrication site for solder mask tolerances between and around signal pads.

DBV0005A



PACKAGE OUTLINE

SOT-23 - 1.45 mm max height

SMALL OUTLINE TRANSISTOR



4214839/D 11/2018

NOTES:

1. All linear dimensions are in millimeters. Any dimensions in parenthesis are for reference only. Dimensioning and tolerancing per ASME Y14.5M.
2. This drawing is subject to change without notice.
3. Reference JEDEC MO-178.
4. Body dimensions do not include mold flash, protrusions, or gate burrs. Mold flash, protrusions, or gate burrs shall not exceed 0.15 mm per side.

EXAMPLE STENCIL DESIGN

DBV0005A

SOT-23 - 1.45 mm max height

SMALL OUTLINE TRANSISTOR



SOLDER PASTE EXAMPLE
BASED ON 0.125 mm THICK STENCIL
SCALE:15X

4214839/D 11/2018

NOTES: (continued)

7. Laser cutting apertures with trapezoidal walls and rounded corners may offer better paste release. IPC-7525 may have alternate design recommendations.
8. Board assembly site may have different recommendations for stencil design.



- NOTES:
- A. All linear dimensions are in millimeters.
 - B. This drawing is subject to change without notice.
 - C. Publication IPC-7351 is recommended for alternate designs.
 - D. Laser cutting apertures with trapezoidal walls and also rounding corners will offer better paste release. Customers should contact their board assembly site for stencil design recommendations. Refer to IPC-7525 for other stencil recommendations.
 - E. Customers should contact their board fabrication site for solder mask tolerances between and around signal pads.

IMPORTANT NOTICE AND DISCLAIMER

TI PROVIDES TECHNICAL AND RELIABILITY DATA (INCLUDING DATASHEETS), DESIGN RESOURCES (INCLUDING REFERENCE DESIGNS), APPLICATION OR OTHER DESIGN ADVICE, WEB TOOLS, SAFETY INFORMATION, AND OTHER RESOURCES "AS IS" AND WITH ALL FAULTS, AND DISCLAIMS ALL WARRANTIES, EXPRESS AND IMPLIED, INCLUDING WITHOUT LIMITATION ANY IMPLIED WARRANTIES OF MERCHANTABILITY, FITNESS FOR A PARTICULAR PURPOSE OR NON-INFRINGEMENT OF THIRD PARTY INTELLECTUAL PROPERTY RIGHTS.

These resources are intended for skilled developers designing with TI products. You are solely responsible for (1) selecting the appropriate TI products for your application, (2) designing, validating and testing your application, and (3) ensuring your application meets applicable standards, and any other safety, security, or other requirements. These resources are subject to change without notice. TI grants you permission to use these resources only for development of an application that uses the TI products described in the resource. Other reproduction and display of these resources is prohibited. No license is granted to any other TI intellectual property right or to any third party intellectual property right. TI disclaims responsibility for, and you will fully indemnify TI and its representatives against, any claims, damages, costs, losses, and liabilities arising out of your use of these resources.

TI's products are provided subject to TI's Terms of Sale (www.ti.com/legal/termsofsale.html) or other applicable terms available either on ti.com or provided in conjunction with such TI products. TI's provision of these resources does not expand or otherwise alter TI's applicable warranties or warranty disclaimers for TI products.

Mailing Address: Texas Instruments, Post Office Box 655303, Dallas, Texas 75265
Copyright © 2019, Texas Instruments Incorporated

Looking for pricing, stock, or lifecycle information?

Click below to explore more details on WIN SOURCE:

 [View OPA2354AQDGKRQ1 on WIN SOURCE](#)

 [Texas Instruments](#) Information

Optimize Your Supply Chain with WIN SOURCE Solutions

-  Global Sourcing Solution
-  Obsolete Management
-  Cost Control Management
-  Shortage Management
-  Alternative Solution
-  Excess Inventory Management