



**THE DATASHEET OF  
TPS389033DSET**



## TPS3890

### Low Quiescent Current, 1% Accurate Supervisor with Programmable Delay

#### 1 Features

- Power-On-Reset (POR) Generator with Adjustable Delay Time: 40  $\mu$ s to 30 s
- Very Low Quiescent Current: 2.1  $\mu$ A (Typical)
- High Threshold Accuracy: 1% (max)
- Precision Hysteresis
- Fixed and Adjustable Threshold Voltages:
  - Fixed Thresholds for Standard Rails: 1.2 V to 3.3 V
  - Adjustable Down to 1.15 V
- Manual Reset ( $\overline{\text{MR}}$ ) Input
- Open-Drain  $\overline{\text{RESET}}$  Output
- Temperature Range:  $-40^{\circ}\text{C}$  to  $+125^{\circ}\text{C}$
- Package: 1.5-mm  $\times$  1.5-mm WSON

#### 2 Applications

- DSPs or Microcontrollers
- FPGAs, ASICs
- Notebooks, Desktop Computers
- Smartphones, Hand-Held Products
- Portable, Battery-Powered Products
- Solid-State Drives
- Set-Top Boxes
- Industrial Control Systems

#### 3 Description

The TPS3890 is a precision voltage supervisor with low-quiescent current that monitors system voltages as low as 1.15 V, asserting an open-drain  $\overline{\text{RESET}}$  signal when the SENSE voltage drops below a preset threshold or when the manual reset ( $\overline{\text{MR}}$ ) pin drops to a logic low. The  $\overline{\text{RESET}}$  output remains low for the user-adjustable delay time after the SENSE voltage and manual reset ( $\overline{\text{MR}}$ ) return above the respective thresholds. The TPS3890 family uses a precision reference to achieve 1% threshold accuracy. The reset delay time can be user-adjusted between 40  $\mu$ s and 30 s by connecting the CT pin to an external capacitor. The TPS3890 has a very low quiescent current of 2.1  $\mu$ A and is available in a small 1.5-mm  $\times$  1.5-mm package, making the device well-suited for battery-powered and space-constrained applications. The device is fully specified over a temperature range of  $-40^{\circ}\text{C}$  to  $+125^{\circ}\text{C}$  ( $T_J$ ).

#### Device Information<sup>(1)</sup>

PART NUMBER	PACKAGE	BODY SIZE (NOM)
TPS3890	WSON (6)	1.50 mm $\times$ 1.50 mm

(1) For all available packages, see the orderable addendum at the end of the data sheet.

#### Typical Application Circuit

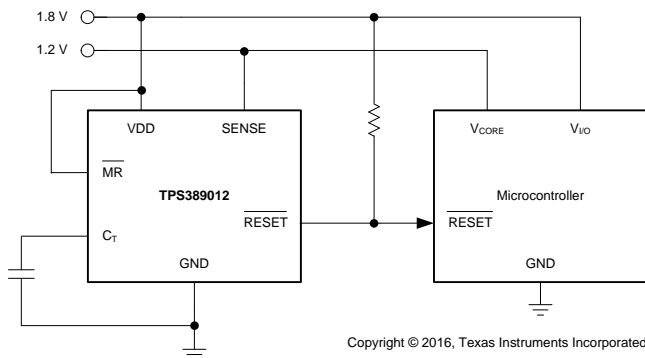

#### V<sub>ITN</sub> Accuracy vs Temperature

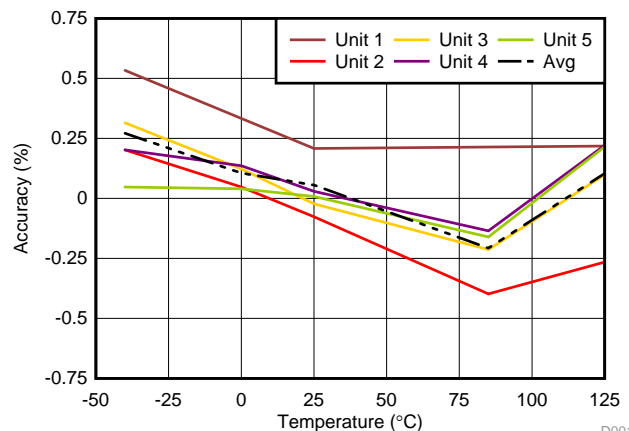

D001



## Table of Contents

<b>1 Features</b> ..... 1 <b>2 Applications</b> ..... 1 <b>3 Description</b> ..... 1 <b>4 Revision History</b> ..... 2 <b>5 Device Comparison Table</b> ..... 3 <b>6 Pin Configuration and Functions</b> ..... 3 <b>7 Specifications</b> ..... 4 7.1 Absolute Maximum Ratings ..... 4 7.2 ESD Ratings ..... 4 7.3 Recommended Operating Conditions ..... 4 7.4 Thermal Information ..... 4 7.5 Electrical Characteristics..... 5 7.6 Timing Requirements ..... 5 7.7 Typical Characteristics ..... 7 <b>8 Detailed Description</b> ..... 11 8.1 Overview ..... 11 8.2 Functional Block Diagram ..... 11	8.3 Feature Description..... 11 8.4 Device Functional Modes..... 14 <b>9 Application and Implementation</b> ..... 15 9.1 Application Information..... 15 9.2 Typical Application ..... 15 <b>10 Power Supply Recommendations</b> ..... 16 <b>11 Layout</b> ..... 17 11.1 Layout Guidelines ..... 17 11.2 Layout Example ..... 17 <b>12 Device and Documentation Support</b> ..... 18 12.1 Documentation Support ..... 18 12.2 Community Resources..... 18 12.3 Trademarks ..... 18 12.4 Electrostatic Discharge Caution..... 18 12.5 Glossary ..... 18 <b>13 Mechanical, Packaging, and Orderable Information</b> ..... 18
---	---

## 4 Revision History

NOTE: Page numbers for previous revisions may differ from page numbers in the current version.

Changes from Original (March 2016) to Revision A	Page
• Released to production.....	1

## 5 Device Comparison Table

PART NUMBER	NOMINAL SUPPLY VOLTAGE	NEGATIVE THRESHOLD ( $V_{ITN}$ )	POSITIVE THRESHOLD ( $V_{ITP}$ )
TPS389001	Adjustable	1.15 V	1.157 V
TPS389012	1.2 V	1.15 V	1.157 V
TPS389015	1.5 V	1.44 V	1.449 V
TPS389018	1.8 V	1.73 V	1.740 V
TPS389020	2.0 V	1.90 V	1.911 V
TPS389025	2.5 V	2.40 V	2.414 V
TPS389030	3.0 V	2.89 V	2.907 V
TPS389033	3.3 V	3.17 V	3.189 V

## 6 Pin Configuration and Functions

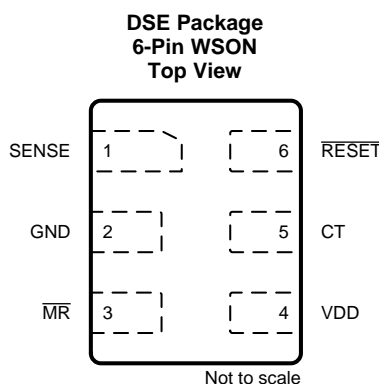

### Pin Functions

PIN		I/O	DESCRIPTION
NO.	NAME		
5	CT	—	The <b>CT</b> pin offers a user-adjustable delay time. Connecting this pin to a ground-referenced capacitor sets the <b>RESET</b> delay time to deassert. $t_{PD(r)} \text{ (sec)} = C_{CT} \text{ (}\mu\text{F)} \times 1.07 + 25 \mu\text{s (nom)}$ .
2	GND	—	Ground
3	$\overline{\text{MR}}$	I	Driving the manual reset pin ( $\overline{\text{MR}}$ ) low causes $\overline{\text{RESET}}$ to go low (assert).
6	$\overline{\text{RESET}}$	O	$\overline{\text{RESET}}$ is an open-drain output that is driven to a low-impedance state when either the $\overline{\text{MR}}$ pin is driven to a logic low or the monitored voltage on the SENSE pin is lower than the negative threshold voltage ( $V_{ITN}$ ). $\overline{\text{RESET}}$ remains low (asserted) for the delay time period after both $\overline{\text{MR}}$ is set to a logic high and the SENSE input is above $V_{ITP}$ . A pullup resistor from 10 k $\Omega$ to 1 M $\Omega$ can be used on this pin.
1	SENSE	I	This pin is connected to the voltage to be monitored. When the voltage on SENSE falls below the negative threshold voltage $V_{ITN}$ , $\overline{\text{RESET}}$ goes low (asserts). When the voltage on SENSE rises above the positive threshold voltage $V_{ITP}$ , $\overline{\text{RESET}}$ goes high (deasserts).
4	VDD	I	Supply voltage pin. Good analog design practice is to place a 0.1- $\mu\text{F}$ ceramic capacitor close to this pin.

## 7 Specifications

### 7.1 Absolute Maximum Ratings

over operating junction temperature range (unless otherwise noted)<sup>(1)</sup>

		MIN	MAX	UNIT
Voltage	VDD	-0.3	7	V
	SENSE	-0.3	7	
	RESET	-0.3	7	
	MR	-0.3	7	
	V <sub>CT</sub>	-0.3	7	
Current	RESET	-20	20	mA
Temperature	Operating junction temperature, T <sub>J</sub>	-40	125	°C
	Storage temperature, T <sub>stg</sub>	-65	150	

- (1) Stresses beyond those listed under *Absolute Maximum Ratings* may cause permanent damage to the device. These are stress ratings only, which do not imply functional operation of the device at these or any other conditions beyond those indicated under *Recommended Operating Conditions*. Exposure to absolute-maximum-rated conditions for extended periods may affect device reliability.

### 7.2 ESD Ratings

		VALUE	UNIT
V <sub>(ESD)</sub> Electrostatic discharge	Human-body model (HBM), per ANSI/ESDA/JEDEC JS-001 <sup>(1)</sup>	±1000	V
	Charged-device model (CDM), per JEDEC specification JESD22-C101 <sup>(2)</sup>	±750	

- (1) JEDEC document JEP155 states that 500-V HBM allows safe manufacturing with a standard ESD control process. Manufacturing with less than 500-V HBM is possible with the necessary precautions.  
 (2) JEDEC document JEP157 states that 250-V CDM allows safe manufacturing with a standard ESD control process. Manufacturing with less than 250-V CDM is possible with the necessary precautions.

### 7.3 Recommended Operating Conditions

over operating free-air temperature range (unless otherwise noted)

		MIN	NOM	MAX	UNIT
V <sub>DD</sub>	Power-supply voltage	1.5		5.5	V
V <sub>SENSE</sub>	SENSE voltage	0		5.5	V
V <sub>RESET</sub>	RESET pin voltage	0		5.5	V
I <sub>RESET</sub>	RESET pin current	-5		5	mA
C <sub>IN</sub>	Input capacitor, VDD pin	0	0.1		μF
C <sub>CT</sub>	Reset timeout capacitor, CT pin	0		22	μF
R <sub>PU</sub>	Pullup resistor, RESET pin	1		1000	kΩ
T <sub>J</sub>	Junction temperature (free-air temperature)	-40	25	125	°C

### 7.4 Thermal Information

THERMAL METRIC <sup>(1)</sup>		TPS3890	UNIT
		DSE (WSO)	
		6 PINS	
R <sub>θJA</sub>	Junction-to-ambient thermal resistance	321.3	°C/W
R <sub>θJC(top)</sub>	Junction-to-case (top) thermal resistance	207.9	°C/W
R <sub>θJB</sub>	Junction-to-board thermal resistance	281.5	°C/W
ψ <sub>JT</sub>	Junction-to-top characterization parameter	42.4	°C/W
ψ <sub>JB</sub>	Junction-to-board characterization parameter	284.8	°C/W
R <sub>θJC(bot)</sub>	Junction-to-case (bottom) thermal resistance	142.3	°C/W

- (1) For more information about traditional and new thermal metrics, see the *Semiconductor and IC Package Thermal Metrics* application report, [SPRA953](http://SPRA953).

## 7.5 Electrical Characteristics

over the operating junction temperature range of  $-40^{\circ}\text{C}$  to  $+125^{\circ}\text{C}$ ,  $1.5\text{ V} \leq V_{\text{DD}} \leq 5.5\text{ V}$ , and  $\overline{\text{MR}} = V_{\text{DD}}$  (unless otherwise noted); typical values are at  $V_{\text{DD}} = 5.5\text{ V}$  and  $T_{\text{J}} = 25^{\circ}\text{C}$

PARAMETER		TEST CONDITIONS	MIN	TYP	MAX	UNIT
$V_{\text{DD}}$	Input supply voltage		1.5		5.5	V
$V_{\text{POR}}$	Power-on reset voltage	$V_{\text{OL(max)}} = 0.2\text{ V}$ , $I_{\text{RESET}} = 15\ \mu\text{A}$			0.8	V
$I_{\text{DD}}$	Supply current (into VDD pin)	$V_{\text{DD}} = 3.3\text{ V}$ , $I_{\text{RESET}} = 0\text{ mA}$ , $-40^{\circ}\text{C} < T_{\text{J}} < 85^{\circ}\text{C}$		2.09	3.72	$\mu\text{A}$
		$V_{\text{DD}} = 3.3\text{ V}$ , $I_{\text{RESET}} = 0\text{ mA}$ , $-40^{\circ}\text{C} < T_{\text{J}} < 105^{\circ}\text{C}$			4.5	
		$V_{\text{DD}} = 3.3\text{ V}$ , $I_{\text{RESET}} = 0\text{ mA}$			5.8	
		$V_{\text{DD}} = 5.5\text{ V}$ , $I_{\text{RESET}} = 0\text{ mA}$ , $-40^{\circ}\text{C} < T_{\text{J}} < 85^{\circ}\text{C}$		2.29	4	
		$V_{\text{DD}} = 5.5\text{ V}$ , $I_{\text{RESET}} = 0\text{ mA}$ , $-40^{\circ}\text{C} < T_{\text{J}} < 105^{\circ}\text{C}$			5.2	
		$V_{\text{DD}} = 5.5\text{ V}$ , $I_{\text{RESET}} = 0\text{ mA}$			6.5	
$V_{\text{ITN}}$ , $V_{\text{ITP}}$	SENSE input threshold voltage accuracy		-1%	$\pm 0.5\%$	1%	
$V_{\text{HYST}}$	Hysteresis <sup>(1)</sup>		0.325%	0.575%	0.825%	
$I_{\text{SENSE}}$	Input current	$V_{\text{SENSE}} = 5\text{ V}$			8	$\mu\text{A}$
		$V_{\text{SENSE}} = 5\text{ V}$ , TPS389001, TPS389012		10	100	nA
$I_{\text{CT}}$	CT pin charge current		0.90	1.15	1.35	$\mu\text{A}$
$V_{\text{CT}}$	CT pin comparator threshold voltage		1.17	1.23	1.29	V
$R_{\text{CT}}$	CT pin pulldown resistance	When $\overline{\text{RESET}}$ is deasserted		200		$\Omega$
$V_{\text{IL}}$	Low-level input voltage ( $\overline{\text{MR}}$ pin)			$0.25 \times V_{\text{DD}}$		V
$V_{\text{IH}}$	High-level output voltage		$0.7 \times V_{\text{DD}}$			V
$V_{\text{OL}}$	Low-level output voltage	$V_{\text{DD}} \geq 1.5\text{ V}$ , $I_{\text{RESET}} = 0.4\text{ mA}$			0.25	V
		$V_{\text{DD}} \geq 2.7\text{ V}$ , $I_{\text{RESET}} = 2\text{ mA}$			0.25	
		$V_{\text{DD}} \geq 4.5\text{ V}$ , $I_{\text{RESET}} = 3\text{ mA}$			0.3	
$I_{\text{LKG(OD)}}$	Open-drain output leakage	High impedance, $V_{\text{SENSE}} = V_{\text{RESET}} = 5.5\text{ V}$			250	nA

(1)  $V_{\text{HYST}} = [(V_{\text{ITP}} - V_{\text{ITN}}) / V_{\text{ITN}}] \times 100\%$ .

## 7.6 Timing Requirements

over the operating junction temperature range of  $-40^{\circ}\text{C}$  to  $+125^{\circ}\text{C}$ ,  $1.5\text{ V} \leq V_{\text{DD}} \leq 5.5\text{ V}$ ,  $\overline{\text{MR}} = V_{\text{DD}}$ , and 5% input overdrive<sup>(1)</sup> (unless otherwise noted); typical values are at  $V_{\text{DD}} = 5.5\text{ V}$  and  $T_{\text{J}} = 25^{\circ}\text{C}$

		MIN	NOM	MAX	UNIT
$t_{\text{PD(f)}}$	SENSE (falling) to $\overline{\text{RESET}}$ propagation delay	$C_{\text{T}} = \text{open}$ , $V_{\text{DD}} = 3.3\text{ V}$	18		$\mu\text{s}$
		$C_{\text{T}} = \text{open}$ , $V_{\text{DD}} = 5.5\text{ V}$	8		
$t_{\text{PD(r)}}$	SENSE (rising) to $\overline{\text{RESET}}$ propagation delay	$C_{\text{T}} = \text{open}$ , $V_{\text{DD}} = 3.3\text{ V}$	25		$\mu\text{s}$
$t_{\text{GI(SENSE)}}$	SENSE pin glitch immunity	$V_{\text{DD}} = 5.5\text{ V}$	9		$\mu\text{s}$
$t_{\text{GI(MR)}}$	$\overline{\text{MR}}$ pin glitch immunity	$V_{\text{DD}} = 5.5\text{ V}$	100		ns
$t_{\text{MRW}}$	$\overline{\text{MR}}$ pin pulse duration to assert $\overline{\text{RESET}}$	1			$\mu\text{s}$
$t_{\text{d(MR)}}$	$\overline{\text{MR}}$ pin low to out delay		250		ns
$t_{\text{STRT}}$	Startup delay		325		$\mu\text{s}$

(1) Overdrive =  $| (V_{\text{IN}} / V_{\text{THRESH}} - 1) \times 100\% |$ .

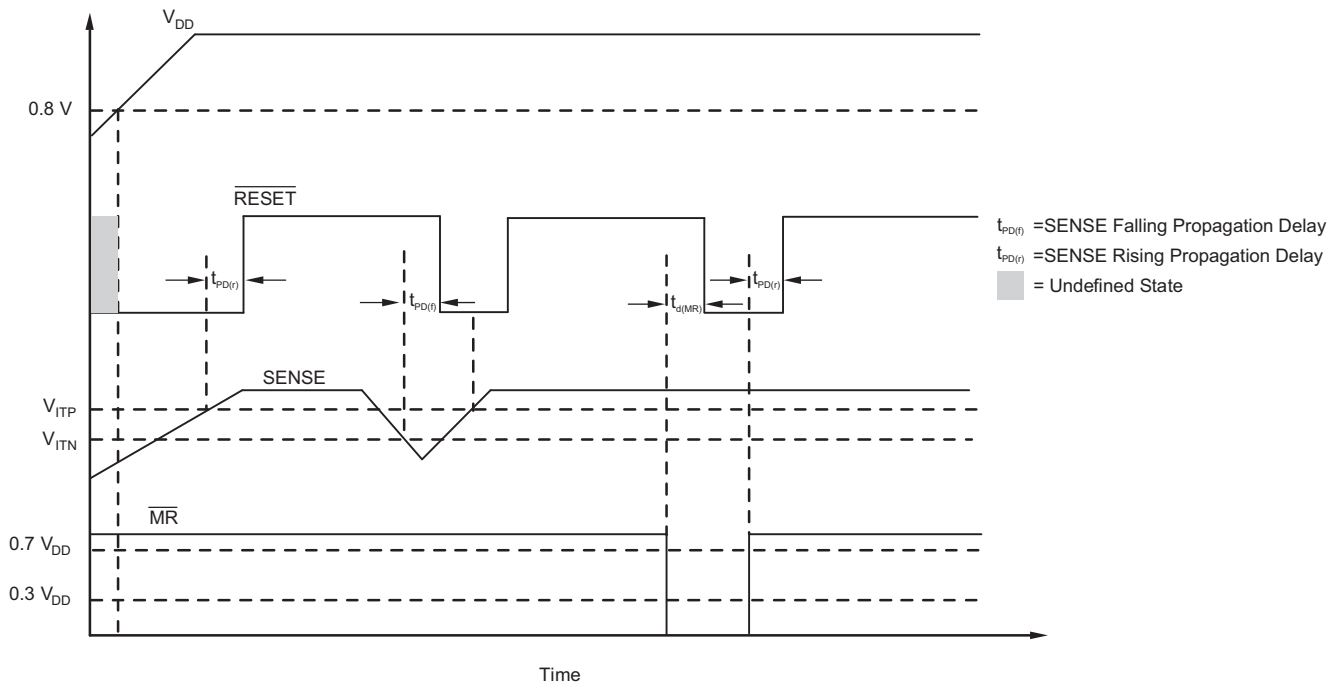

**Figure 1. Timing Diagram**

### 7.7 Typical Characteristics

over the operating junction temperature range of  $-40^{\circ}\text{C}$  to  $+125^{\circ}\text{C}$ ,  $1.5\text{ V} \leq V_{\text{DD}} \leq 5.5\text{ V}$ , and  $\overline{\text{MR}} = V_{\text{DD}}$  (unless otherwise noted)

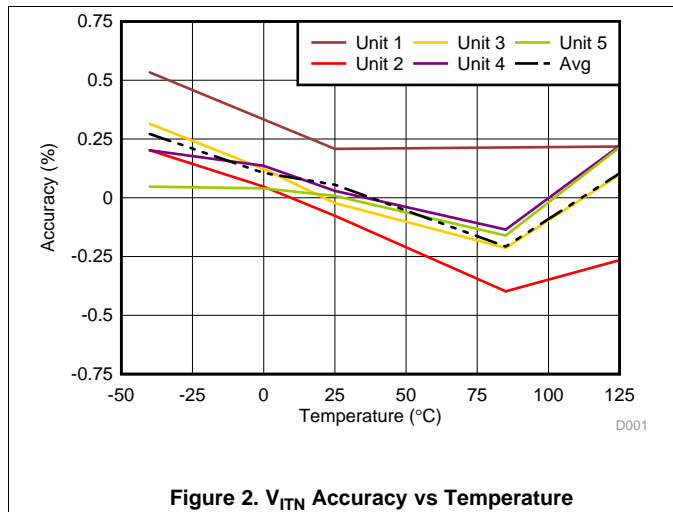

Figure 2.  $V_{\text{ITN}}$  Accuracy vs Temperature

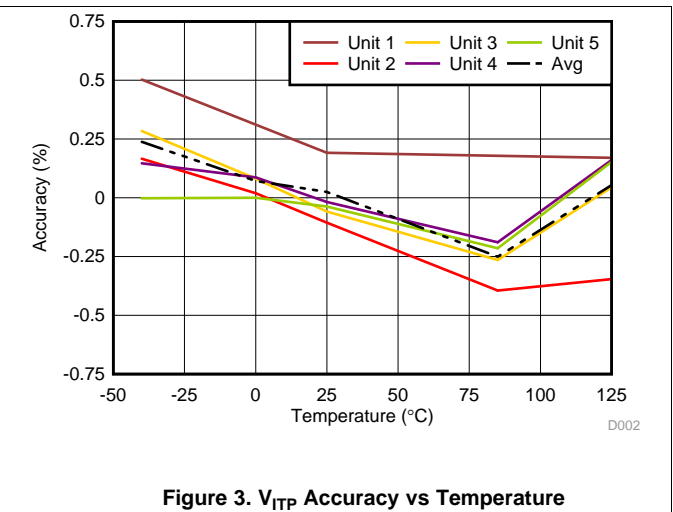
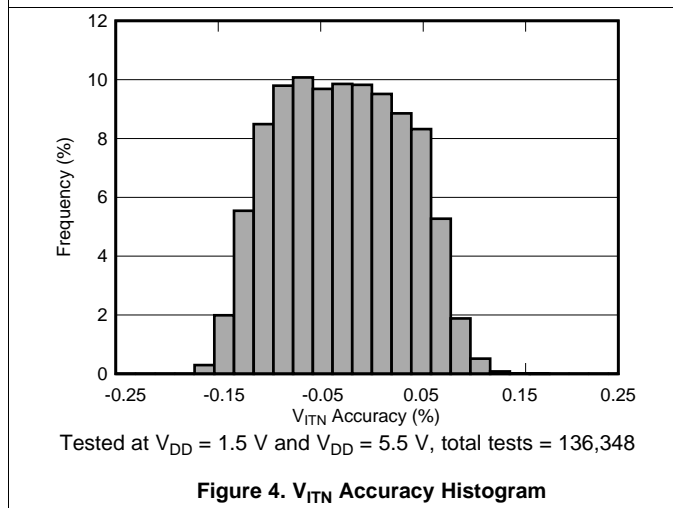
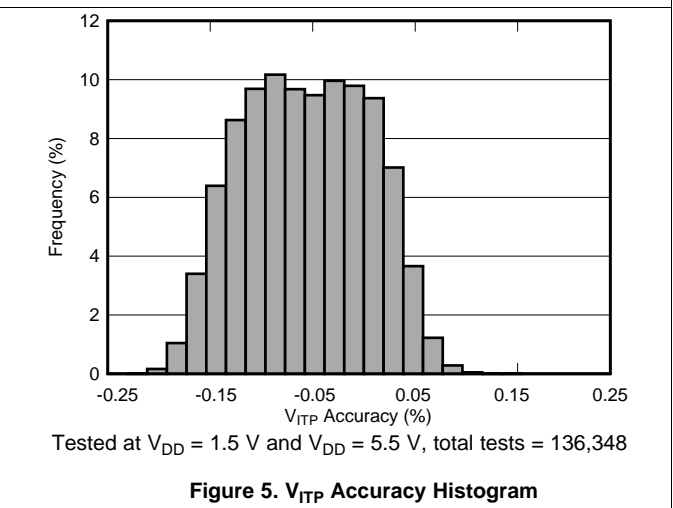

Figure 3.  $V_{\text{ITP}}$  Accuracy vs Temperature



Tested at  $V_{\text{DD}} = 1.5\text{ V}$  and  $V_{\text{DD}} = 5.5\text{ V}$ , total tests = 136,348

Figure 4.  $V_{\text{ITN}}$  Accuracy Histogram



Tested at  $V_{\text{DD}} = 1.5\text{ V}$  and  $V_{\text{DD}} = 5.5\text{ V}$ , total tests = 136,348

Figure 5.  $V_{\text{ITP}}$  Accuracy Histogram

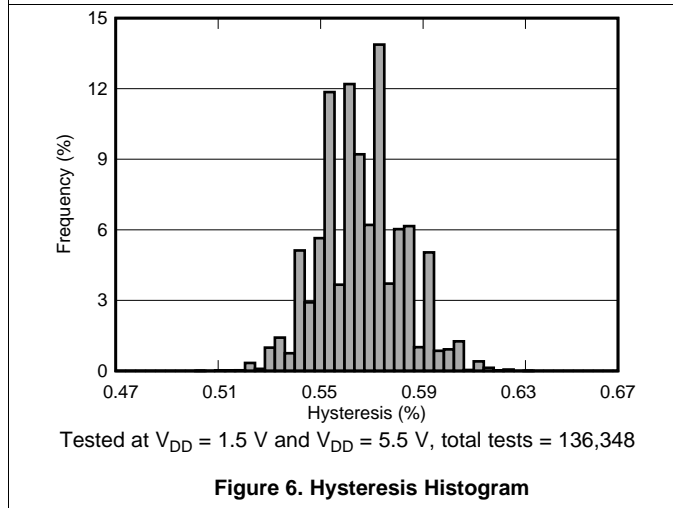

Tested at  $V_{\text{DD}} = 1.5\text{ V}$  and  $V_{\text{DD}} = 5.5\text{ V}$ , total tests = 136,348

Figure 6. Hysteresis Histogram

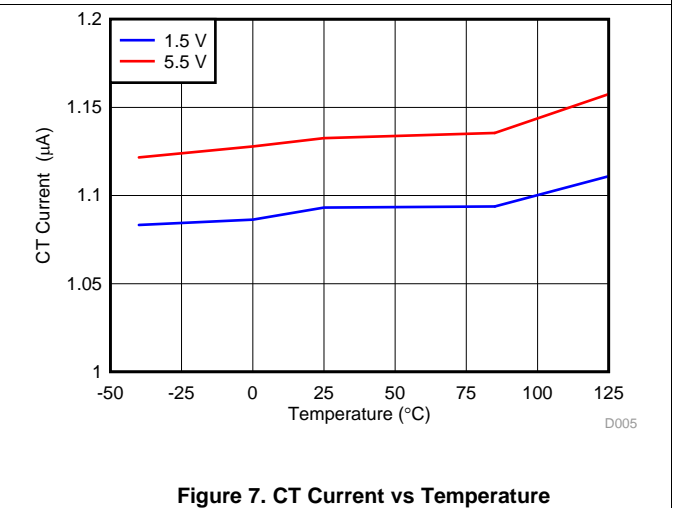

Figure 7. CT Current vs Temperature

### Typical Characteristics (continued)

over the operating junction temperature range of  $-40^{\circ}\text{C}$  to  $+125^{\circ}\text{C}$ ,  $1.5\text{ V} \leq V_{\text{DD}} \leq 5.5\text{ V}$ , and  $\overline{\text{MR}} = V_{\text{DD}}$  (unless otherwise noted)

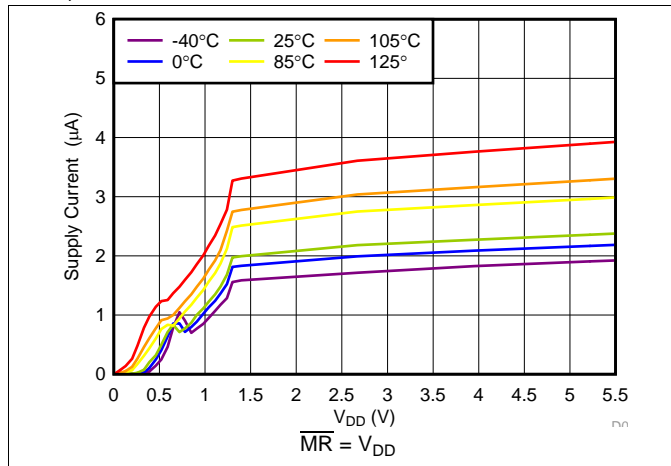

Figure 8. Supply Current vs Power-Supply Voltage

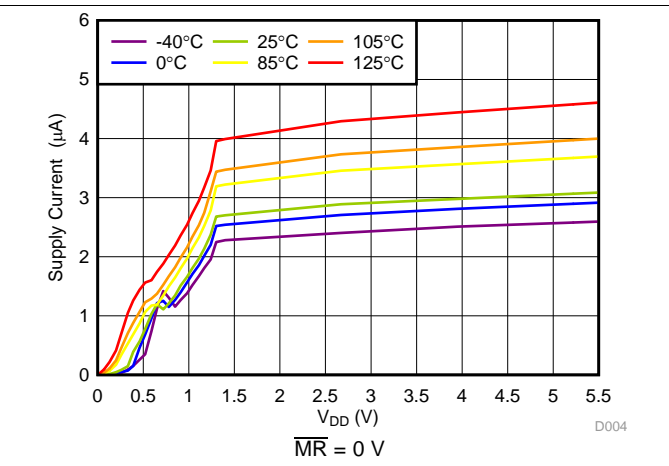

Figure 9. Supply Current vs Power-Supply Voltage

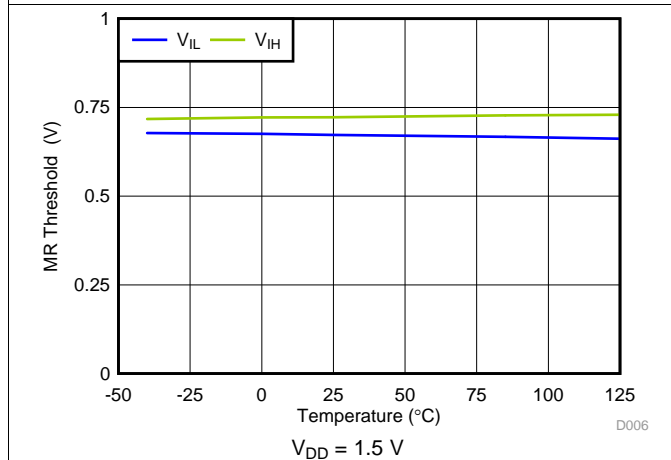

Figure 10.  $\overline{\text{MR}}$  Threshold vs Temperature

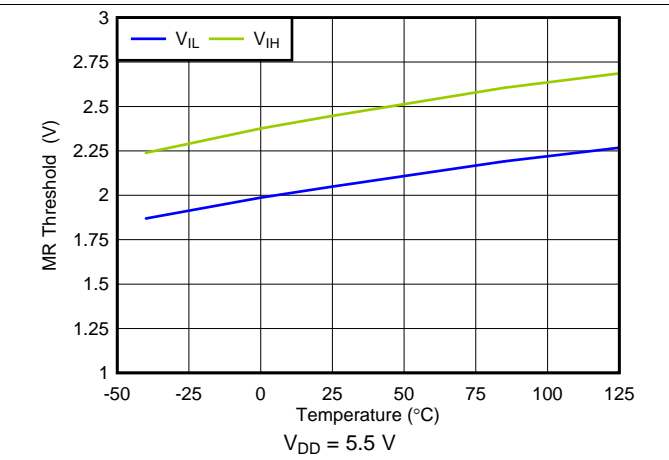

Figure 11.  $\overline{\text{MR}}$  Threshold vs Temperature

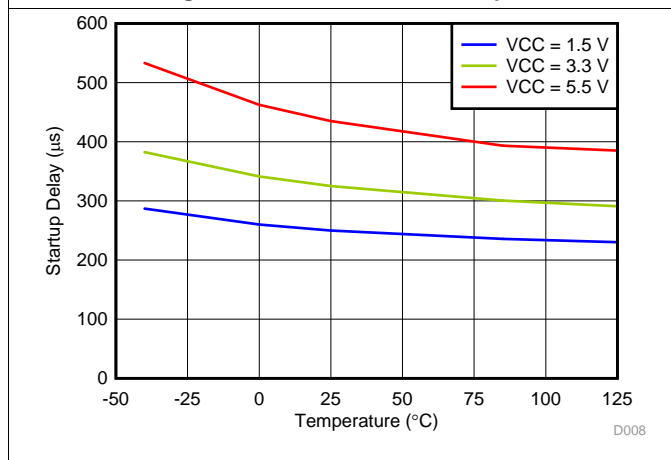

Figure 12. Startup Delay vs Temperature

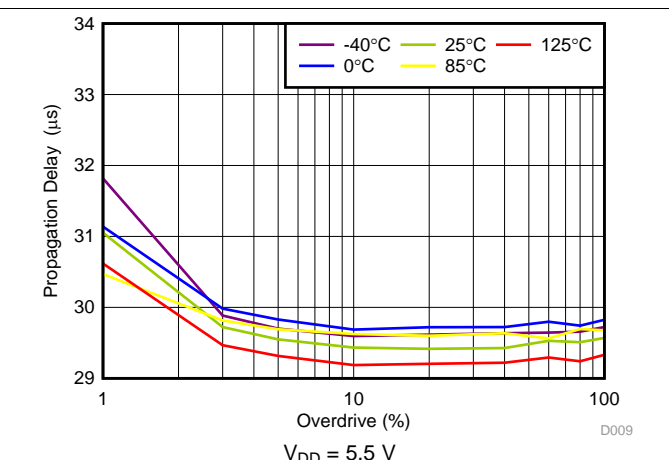

Figure 13. Propagation Delay ( $t_{\text{PD}(r)}$ ) vs Overdrive

Typical Characteristics (continued)

over the operating junction temperature range of  $-40^{\circ}\text{C}$  to  $+125^{\circ}\text{C}$ ,  $1.5\text{ V} \leq V_{\text{DD}} \leq 5.5\text{ V}$ , and  $\overline{\text{MR}} = V_{\text{DD}}$  (unless otherwise noted)

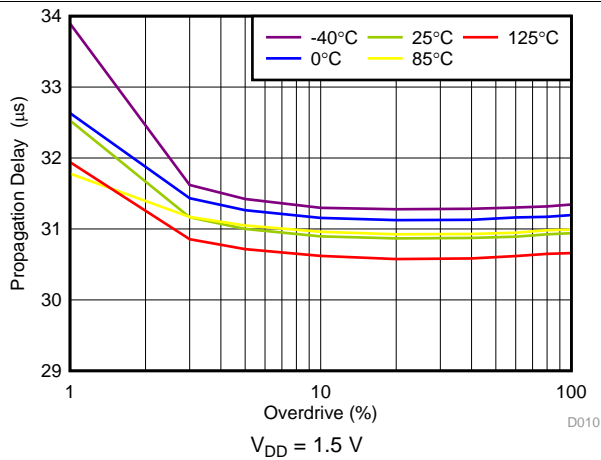

Figure 14. Propagation Delay ( $t_{\text{PD}(r)}$ ) vs Overdrive

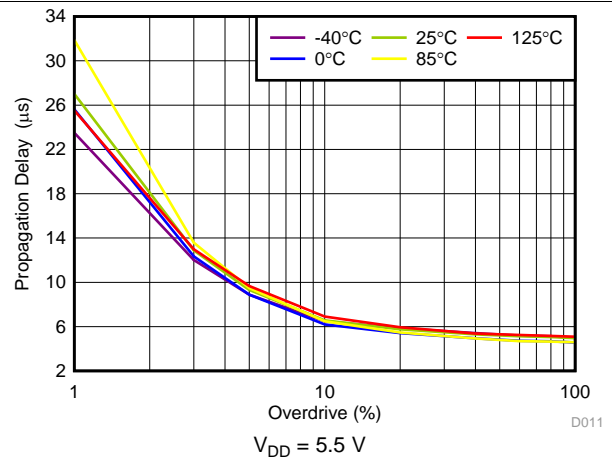

Figure 15. Propagation Delay ( $t_{\text{PD}(r)}$ ) vs Overdrive

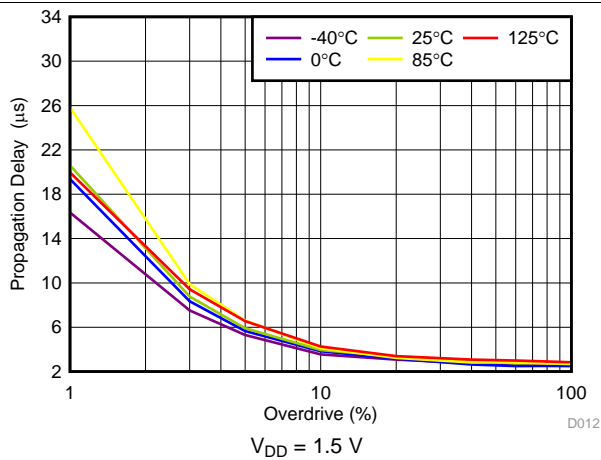

Figure 16. Propagation Delay ( $t_{\text{PD}(r)}$ ) vs Overdrive

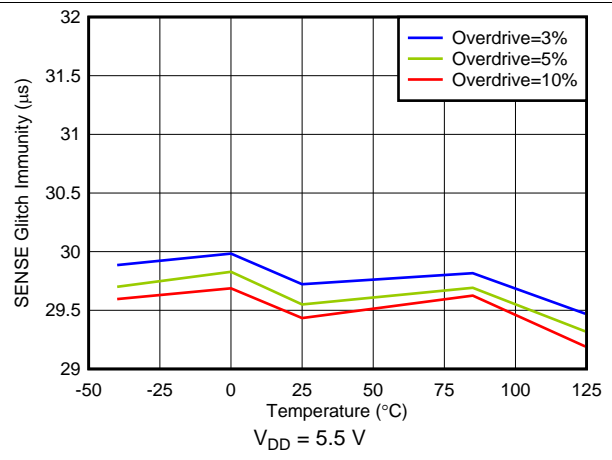

Figure 17. Low-to-High Glitch Immunity vs Temperature

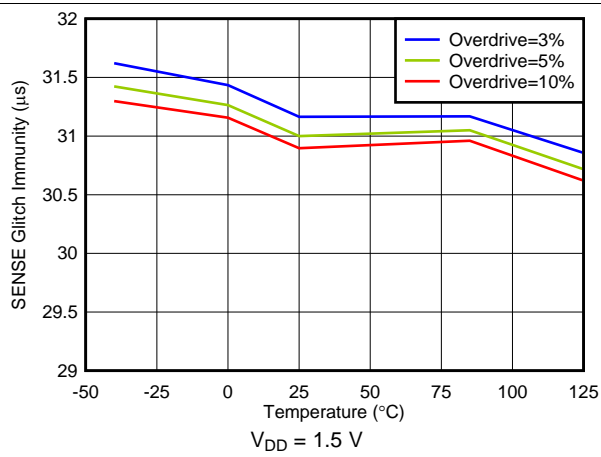

Figure 18. Low-to-High Glitch Immunity vs Temperature

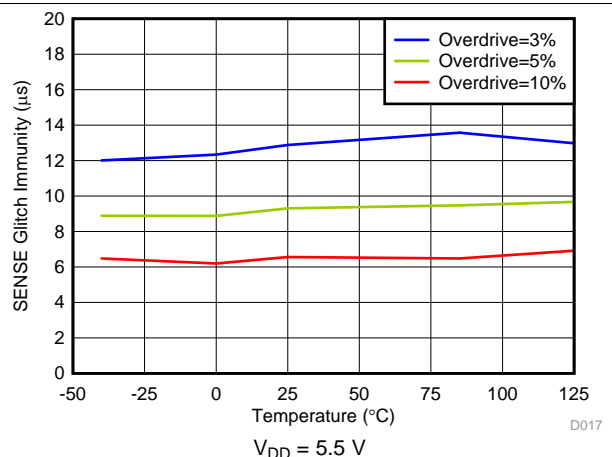

Figure 19. High-to-Low Glitch Immunity vs Temperature

Typical Characteristics (continued)

over the operating junction temperature range of  $-40^{\circ}\text{C}$  to  $+125^{\circ}\text{C}$ ,  $1.5\text{ V} \leq V_{\text{DD}} \leq 5.5\text{ V}$ , and  $\overline{\text{MR}} = V_{\text{DD}}$  (unless otherwise noted)

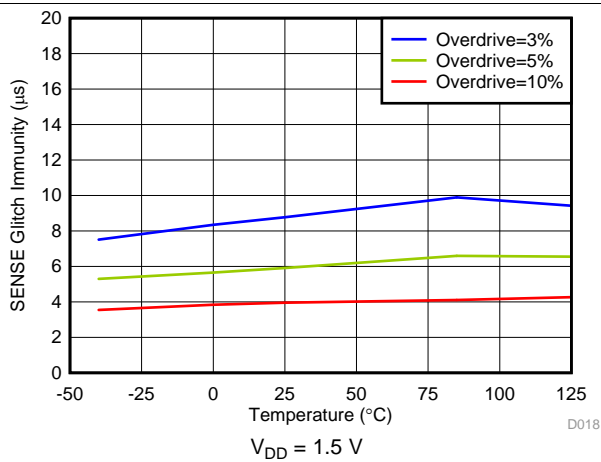

Figure 20. High-to-Low Glitch Immunity vs Temperature

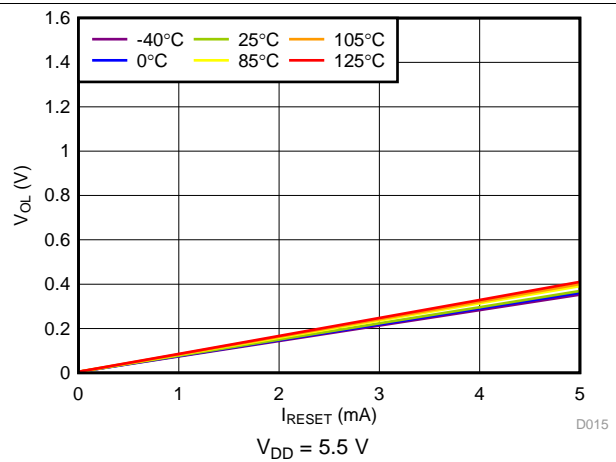

Figure 21. Low-Level Output Voltage vs RESET Current

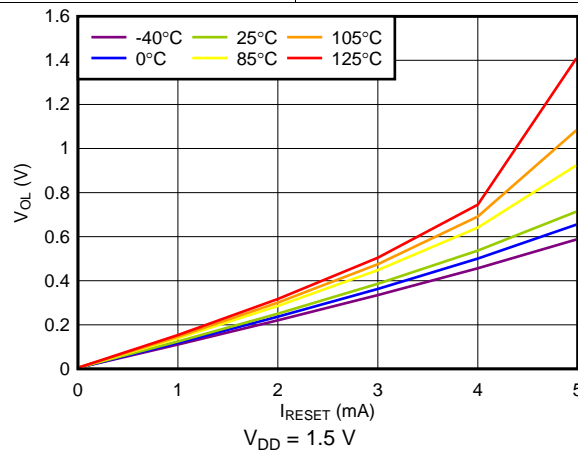

Figure 22. Low-Level Output Voltage vs RESET Current

## 8 Detailed Description

### 8.1 Overview

The TPS3890 supervisory product family is designed to assert a  $\overline{\text{RESET}}$  signal when either the SENSE pin voltage drops below  $V_{\text{ITN}}$  or the manual reset ( $\overline{\text{MR}}$ ) is driven low. The  $\overline{\text{RESET}}$  output remains asserted for a user-adjustable time after both the manual reset ( $\overline{\text{MR}}$ ) and SENSE voltages return above their respective thresholds.

### 8.2 Functional Block Diagram

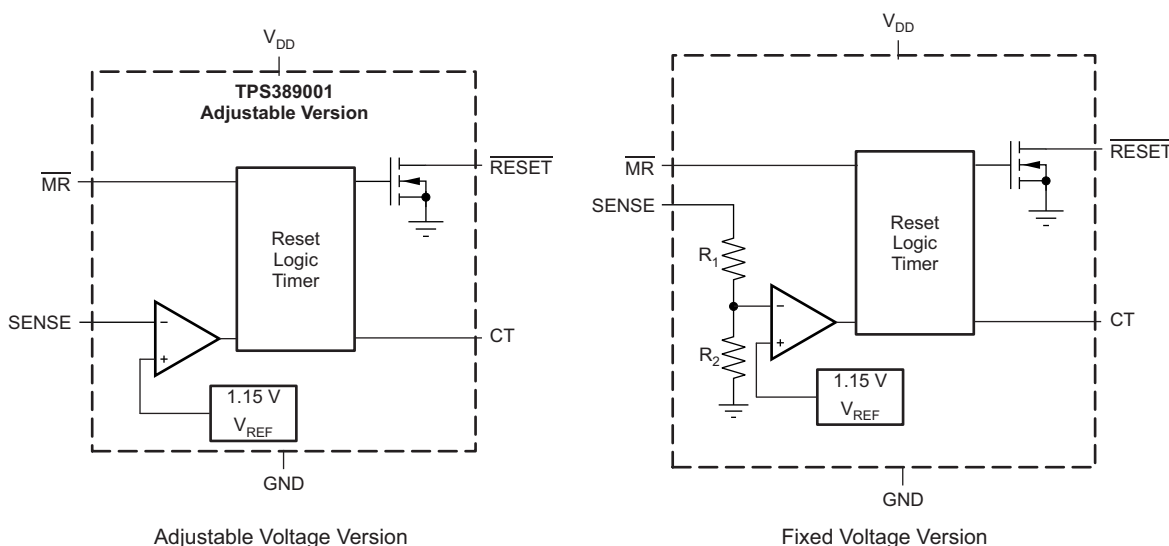

Copyright © 2016, Texas Instruments Incorporated

### 8.3 Feature Description

The combination of user-adjustable reset delay time with a broad range of threshold voltages allow these devices to be used in a wide array of applications. Fixed negative threshold voltages ( $V_{\text{ITN}}$ ) can be factory set from 1.15 V to 3.17 V (see the [Device Comparison Table](#) for available options), and the adjustable device can be used to customize the threshold voltage for other application needs by using an external resistor divider. The CT pin allows the reset delay to be set between 25  $\mu\text{s}$  and 30 s with the use of an external capacitor.

#### 8.3.1 User-Configurable $\overline{\text{RESET}}$ Delay Time

The rising  $\overline{\text{RESET}}$  delay time ( $t_{\text{PD}(r)}$ ) can be configured by installing a capacitor connected to the CT pin. The TPS3890 uses a CT pin charging current ( $I_{\text{CT}}$ ) of 1.15  $\mu\text{A}$  to help counter the effect of capacitor and board-level leakage currents that can be substantial in certain applications. The rising  $\overline{\text{RESET}}$  delay time can be set to any value between 25  $\mu\text{s}$  (no  $C_{\text{CT}}$  installed) and 30 s ( $C_{\text{CT}} = 26 \mu\text{F}$ ).

The capacitor value needed for a given delay time can be calculated using [Equation 1](#):

$$t_{\text{PD}(r)} (\text{SEC}) = C_{\text{CT}} \times V_{\text{CT}} \div I_{\text{CT}} + t_{\text{PD}(r)(\text{nom})} \quad (1)$$

The slope of [Equation 1](#) is determined by the time that the CT charging current ( $I_{\text{CT}}$ ) takes to charge the external capacitor up to the CT comparator threshold voltage ( $V_{\text{CT}}$ ). When  $\overline{\text{RESET}}$  is asserted, the capacitor is discharged through the internal CT pulldown resistor ( $R_{\text{CT}}$ ). When the  $\overline{\text{RESET}}$  conditions are cleared, the internal precision current source is enabled and begins to charge the external capacitor and when the voltage on this capacitor reaches 1.22 V,  $\overline{\text{RESET}}$  is deasserted. Note that in order to minimize the difference between the calculated  $\overline{\text{RESET}}$  delay time and the actual  $\overline{\text{RESET}}$  delay time, use a low-leakage type capacitor (such as a ceramic capacitor) and minimize parasitic board capacitance around this pin.

## Feature Description (continued)

### 8.3.2 Manual Reset ( $\overline{\text{MR}}$ ) Input

The manual reset ( $\overline{\text{MR}}$ ) input allows a processor or other logic circuits to initiate a reset. A logic low on  $\overline{\text{MR}}$  causes  $\overline{\text{RESET}}$  to assert. After  $\overline{\text{MR}}$  returns to a logic high and  $\text{SENSE}$  is above  $V_{\text{ITP}}$ ,  $\overline{\text{RESET}}$  is deasserted after the user-defined reset delay. If  $\overline{\text{MR}}$  is not controlled externally, then  $\overline{\text{MR}}$  must be connected to  $V_{\text{DD}}$ . Note that if the logic signal driving  $\overline{\text{MR}}$  is not greater than or equal to  $V_{\text{DD}}$ , then some additional current flows into  $V_{\text{DD}}$  and out of  $\overline{\text{MR}}$  and the difference is apparent when comparing [Figure 8](#) and [Figure 9](#).

[Figure 23](#) shows how  $\overline{\text{MR}}$  can be used to monitor multiple system voltages when only a single CT capacitor is needed to set the  $\overline{\text{RESET}}$  delay time.

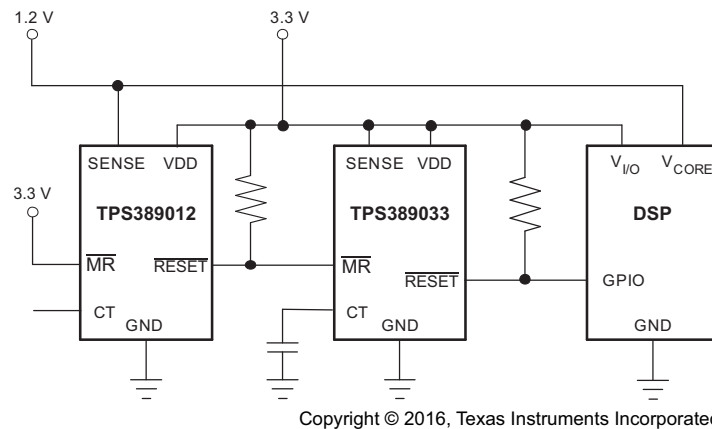

**Figure 23. Using  $\overline{\text{MR}}$  to Monitor Multiple System Voltages**

### 8.3.3 $\overline{\text{RESET}}$ Output

$\overline{\text{RESET}}$  remains high (deasserted) as long as  $\text{SENSE}$  is above the positive threshold ( $V_{\text{ITP}}$ ) and the manual reset signal ( $\overline{\text{MR}}$ ) is logic high. If  $\text{SENSE}$  falls below the negative threshold ( $V_{\text{ITN}}$ ) or if  $\overline{\text{MR}}$  is driven low, then  $\overline{\text{RESET}}$  is asserted, driving the  $\overline{\text{RESET}}$  pin to a low impedance.

When  $\overline{\text{MR}}$  is again logic high and  $\text{SENSE}$  is above  $V_{\text{ITP}}$ , a delay circuit is enabled that holds  $\overline{\text{RESET}}$  low for a specified reset delay period ( $t_{\text{PD}(r)}$ ). When the reset delay has elapsed, the  $\overline{\text{RESET}}$  pin goes to a high-impedance state and uses a pullup resistor to hold  $\overline{\text{RESET}}$  high. Connect the pullup resistor to the proper voltage rail to enable the outputs to be connected to other devices at the correct interface voltage level.  $\overline{\text{RESET}}$  can be pulled up to any voltage up to 5.5 V, independent of the device supply voltage. To ensure proper voltage levels, give some consideration when choosing the pullup resistor values. The pullup resistor value is determined by  $V_{\text{OL}}$ , the output capacitive loading, and the output leakage current ( $I_{\text{LKG(OD)}}$ ).

### 8.3.4 $\text{SENSE}$ Input

The  $\text{SENSE}$  input can vary from ground to 5.5 V (7.0 V, absolute maximum), regardless of the device supply voltage used. The  $\text{SENSE}$  pin is used to monitor the critical voltage rail. If the voltage on this pin drops below  $V_{\text{ITN}}$ , then  $\overline{\text{RESET}}$  is asserted. When the voltage on the  $\text{SENSE}$  pin exceeds the positive threshold voltage,  $\overline{\text{RESET}}$  deasserts after the user-defined  $\overline{\text{RESET}}$  delay time.

The internal comparator has built-in hysteresis to ensure well-defined  $\overline{\text{RESET}}$  assertions and deassertions even when there are small changes on the voltage rail being monitored.

The TPS3890 device is relatively immune to short transients on the  $\text{SENSE}$  pin. Glitch immunity is dependent on threshold overdrive, as illustrated in [Figure 19](#) for  $V_{\text{ITN}}$  and [Figure 18](#) for  $V_{\text{ITP}}$ . Although not required in most cases, for noisy applications good analog design practice is to place a 1-nF to 10-nF bypass capacitor at the  $\text{SENSE}$  input to reduce sensitivity to transient voltages on the monitored signal.

## Feature Description (continued)

The adjustable version (TPS389001) can be used to monitor any voltage rail down to 1.15 V using the circuit shown in [Figure 24](#).

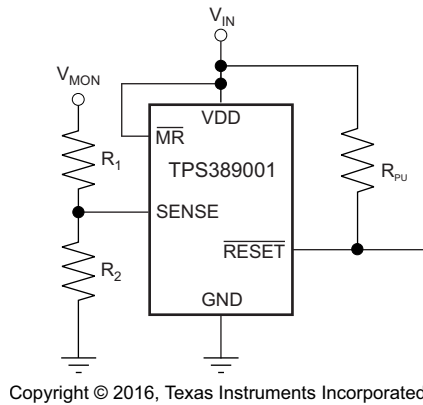

**Figure 24. Using the TPS389001 to Monitor a User-Defined Threshold Voltage**

The target threshold voltage for the monitored supply ( $V_{ITx(MON)}$ ) and the resistor divider values can be calculated by using [Equation 2](#) and [Equation 3](#), respectively:

$$V_{ITx(MON)} = V_{ITx} \times (1 + R_1 \div R_2) \quad (2)$$

[Equation 3](#) can be used to calculate either the negative threshold or the positive threshold by replacing  $V_{ITx}$  with either  $V_{ITN}$  or  $V_{ITP}$ , respectively.

$$R_{TOTAL} = R_1 + R_2 \quad (3)$$

Resistors with high values minimize current consumption; however, the input bias current of the device degrades accuracy if the current through the resistors is too low. Therefore, choosing an  $R_{TOTAL}$  value so that the current through the resistor divider is at least 100 times larger than the SENSE input current is simplest. See application report *Optimizing Resistor Dividers at a Comparator Input* ([SLVA450](#)) for more details on sizing input resistors.

### 8.3.4.1 Immunity to SENSE Pin Voltage Transients

The TPS3702 is immune to short voltage transient spikes on the input pins. Sensitivity to transients depends on both transient duration and overdrive (amplitude) of the transient. Overdrive is defined by how much  $V_{SENSE}$  exceeds the specified threshold, and is important to know because the smaller the overdrive, the slower the response of the outputs (that is, undervoltage and overvoltage). Threshold overdrive is calculated as a percent of the threshold in question, as shown in [Equation 4](#).

$$\text{Overdrive} = | (V_{SENSE} / V_{ITx} - 1) \times 100\% | \quad (4)$$

[Figure 17](#) to [Figure 20](#) illustrate the glitch immunity that the TPS3890 has versus temperature with three different overdrive voltages. The propagation delay versus overdrive curves ([Figure 13](#) to [Figure 16](#)) can be used to determine how sensitive the TPS3890 family of devices are across an even wider range of overdrive voltages.

## 8.4 Device Functional Modes

Table 1 summarizes the various functional modes of the device.

**Table 1. Truth Table**

$V_{DD}$	$\overline{MR}$	SENSE	$\overline{RESET}$
$V_{DD} < V_{POR}$	—	—	Undefined
$V_{POR} < V_{DD} < V_{DD(MIN)}^{(1)}$	—	—	L
$V_{DD} \geq V_{DD(MIN)}$	L	—	L
$V_{DD} \geq V_{DD(MIN)}$	H	$V_{SENSE} < V_{ITN}$	L
$V_{DD} \geq V_{DD(MIN)}$	H	$V_{SENSE} > V_{ITP}$	H

(1) When  $V_{DD}$  falls below  $V_{DD(MIN)}$ , undervoltage-lockout (UVLO) takes effect and  $\overline{RESET}$  is held low until  $V_{DD}$  falls below  $V_{POR}$ .

### 8.4.1 Normal Operation ( $V_{DD} > V_{DD(min)}$ )

When  $V_{DD}$  is greater than  $V_{DD(min)}$ , the  $\overline{RESET}$  signal is determined by the voltage on the SENSE pin and the logic state of  $\overline{MR}$ .

- $\overline{MR}$  high: when the voltage on  $V_{DD}$  is greater than 1.5 V, the  $\overline{RESET}$  signal corresponds to the voltage on the SENSE pin relative to the threshold voltage.
- $\overline{MR}$  low: in this mode,  $\overline{RESET}$  is held low regardless of the voltage on the SENSE pin.

### 8.4.2 Above Power-On-Reset But Less Than $V_{DD(min)}$ ( $V_{POR} < V_{DD} < V_{DD(min)}$ )

When the voltage on  $V_{DD}$  is less than the  $V_{DD(min)}$  voltage, and greater than the power-on-reset voltage ( $V_{POR}$ ), the  $\overline{RESET}$  signal is asserted regardless of the voltage on the SENSE pin.

### 8.4.3 Below Power-On-Reset ( $V_{DD} < V_{POR}$ )

When the voltage on  $V_{DD}$  is lower than  $V_{POR}$ , the device does not have enough voltage to internally pull the asserted output low and  $\overline{RESET}$  is undefined and must not be relied upon for proper device function.

## 9 Application and Implementation

### NOTE

Information in the following applications sections is not part of the TI component specification, and TI does not warrant its accuracy or completeness. TI's customers are responsible for determining suitability of components for their purposes. Customers should validate and test their design implementation to confirm system functionality.

### 9.1 Application Information

The following sections describe in detail how to properly use this device, depending on the requirements of the final application.

### 9.2 Typical Application

A typical application for the TPS389018 is shown in [Figure 25](#). The TPS389018 can be used to monitor the 1.8-V VDD rail required by the TI Delfino™ microprocessor family. The open-drain RESET output of the TPS389018 is connected to the XRS input of the microprocessor. A reset event is initiated when the VDD voltage is less than  $V_{ITN}$  or when MR is driven low by an external source.

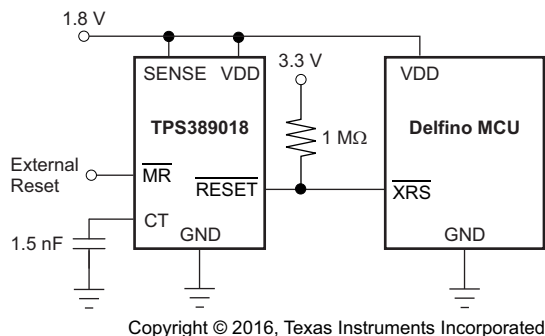

**Figure 25. TPS3890 Monitoring the Supply Voltage for a Delfino Microprocessor**

#### 9.2.1 Design Requirements

The TPS3890 RESET output can be used to drive the reset ( $\overline{XRS}$ ) input of a microprocessor. The RESET pin of the TPS3890 is pulled high with a 1-M $\Omega$  resistor; the reset delay time is controlled by the CT capacitor and is set depending on the reset requirement times of the microprocessor. During power-up, XRS must remain low for at least 1 ms after VDD reaches 1.5 V for the C2000™ Delfino family of microprocessors. For 100-MHz operation, the Delfino TMS320F2833x microcontroller uses a supply voltage of 1.8 V that must be monitored by the TPS3890.

#### 9.2.2 Detailed Design Procedure

The primary constraint for this application is choosing the correct device to monitor the supply voltage of the microprocessor. The TPS389018 has a negative threshold of 1.73 V and a positive threshold of 1.74 V, making the device suitable for monitoring a 1.8-V rail. The secondary constraint for this application is the reset delay time that must be at least 1 ms to allow the Delfino microprocessor enough time to startup up correctly. Because a minimum time is required, the worst-case scenario is a supervisor with a high CT charging current ( $I_{CT}$ ) and a low CT comparator threshold ( $V_{CT}$ ). For applications with ambient temperatures ranging from  $-40^{\circ}\text{C}$  to  $+125^{\circ}\text{C}$ ,  $C_{CT}$  can be calculated using  $I_{CT(\text{Max})}$ ,  $V_{CT(\text{Min})}$ , and solving for  $C_{CT}$  in [Equation 1](#) such that the minimum capacitance required at the CT pin is 1.149 nF. If standard capacitors with  $\pm 20\%$  tolerances are used, then the CT capacitor must be 1.5 nF or larger to ensure that the 1-ms delay time is met.

A 0.1- $\mu\text{F}$  decoupling capacitor is connected to the VDD pin as a good analog design practice and a 1-M $\Omega$  resistor is used as the RESET pullup resistor to minimize the current consumption when RESET is asserted. The MR pin can be connected to an external signal if desired or connected to VDD if not used.

## Typical Application (continued)

### 9.2.3 Application Curve

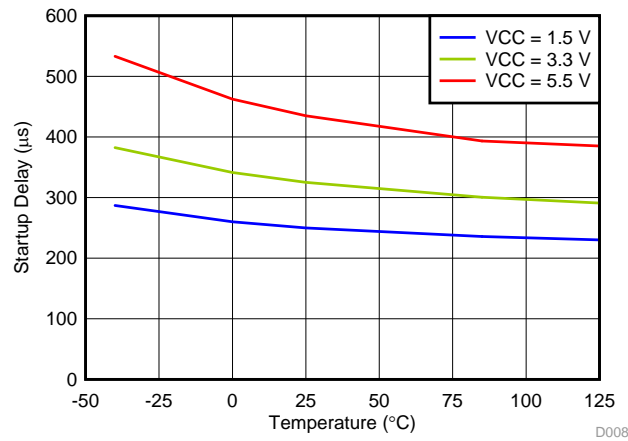

**Figure 26. Startup Delay vs Temperature**

## 10 Power Supply Recommendations

These devices are designed to operate from an input supply with a voltage range between 1.5 V and 5.5 V. An input supply capacitor is not required for this device; however, if the input supply is noisy, then good analog practice is to place a 0.1- $\mu$ F capacitor between the VDD pin and the GND pin. This device has a 7-V absolute maximum rating on the VDD pin. If the voltage supply providing power to VDD is susceptible to any large voltage transient that can exceed 7 V, additional precautions must be taken.

## 11 Layout

### 11.1 Layout Guidelines

Make sure that the connection to the VDD pin is low impedance. Good analog design practice is to place a 0.1- $\mu\text{F}$  ceramic capacitor near the VDD pin. If a capacitor is not connected to the CT pin, then minimize parasitic capacitance on this pin so the RESET delay time is not adversely affected.

### 11.2 Layout Example

The layout example in shows how the TPS3890 is laid out on a printed circuit board (PCB) with a user-defined delay.

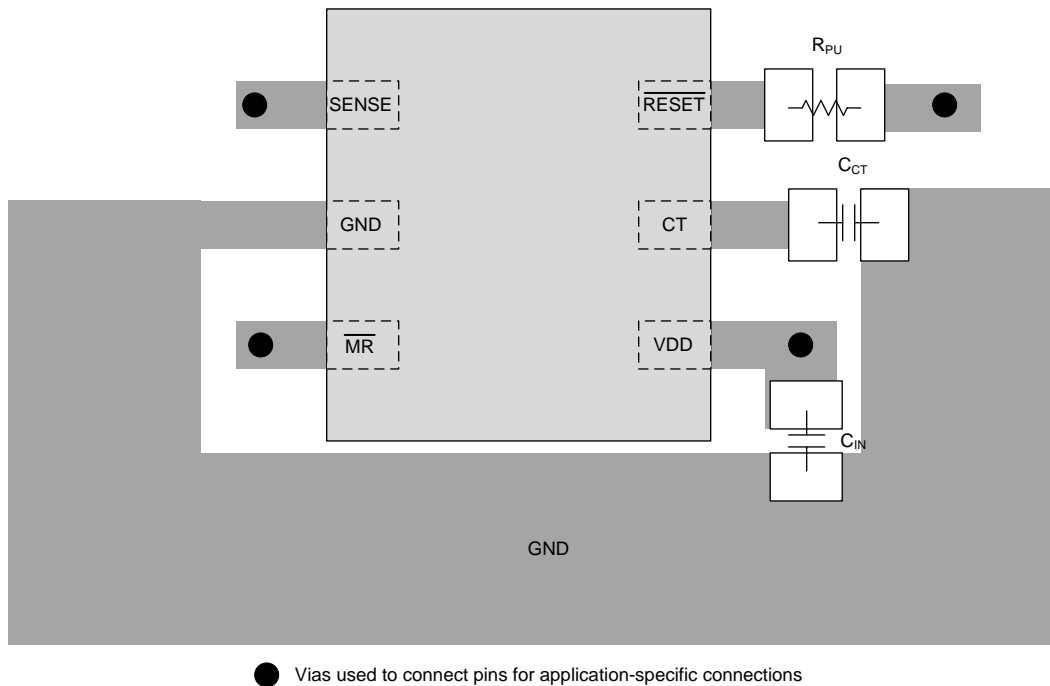

**Figure 27. Recommended Layout**

## 12 Device and Documentation Support

### 12.1 Documentation Support

#### 12.1.1 Related Documentation

The following related documents are available for download at [www.ti.com](http://www.ti.com):

- *Optimizing Resistor Dividers at a Comparator Input*, [SLVA450](#)
- *Sensitivity Analysis for Power Supply Design*, [SLVA481](#)
- *Getting Started With TMS320C28x Digital Signal Controllers*, [SPRAAM0](#)
- TPS3890EVM-775 Evaluation Module User Guide, [SBVU030](#)
- [C2000 Delfino Family of Microprocessors](#)
- [TMS320F2833x](#) microcontroller, [SPRS439](#)

### 12.2 Community Resources

The following links connect to TI community resources. Linked contents are provided "AS IS" by the respective contributors. They do not constitute TI specifications and do not necessarily reflect TI's views; see TI's [Terms of Use](#).

**TI E2E™ Online Community** *TI's Engineer-to-Engineer (E2E) Community*. Created to foster collaboration among engineers. At [e2e.ti.com](http://e2e.ti.com), you can ask questions, share knowledge, explore ideas and help solve problems with fellow engineers.

**Design Support** *TI's Design Support* Quickly find helpful E2E forums along with design support tools and contact information for technical support.

### 12.3 Trademarks

Delfino, C2000, E2E are trademarks of Texas Instruments.  
All other trademarks are the property of their respective owners.

### 12.4 Electrostatic Discharge Caution



This integrated circuit can be damaged by ESD. Texas Instruments recommends that all integrated circuits be handled with appropriate precautions. Failure to observe proper handling and installation procedures can cause damage.

ESD damage can range from subtle performance degradation to complete device failure. Precision integrated circuits may be more susceptible to damage because very small parametric changes could cause the device not to meet its published specifications.

### 12.5 Glossary

[SLYZ022](#) — *TI Glossary*.

This glossary lists and explains terms, acronyms, and definitions.

## 13 Mechanical, Packaging, and Orderable Information

The following pages include mechanical, packaging, and orderable information. This information is the most current data available for the designated devices. This data is subject to change without notice and revision of this document. For browser-based versions of this data sheet, refer to the left-hand navigation.

**PACKAGING INFORMATION**

Orderable Device	Status (1)	Package Type	Package Drawing	Pins	Package Qty	Eco Plan (2)	Lead/Ball Finish (6)	MSL Peak Temp (3)	Op Temp (°C)	Device Marking (4/5)	Samples
TPS389001DSER	ACTIVE	WSO	DSE	6	3000	Green (RoHS & no Sb/Br)	CU NIPDAU	Level-1-260C-UNLIM	-40 to 125	2V	<a href="#">Samples</a>
TPS389001DSET	ACTIVE	WSO	DSE	6	250	Green (RoHS & no Sb/Br)	CU NIPDAU	Level-1-260C-UNLIM	-40 to 125	2V	<a href="#">Samples</a>
TPS389012DSER	ACTIVE	WSO	DSE	6	3000	Green (RoHS & no Sb/Br)	CU NIPDAU	Level-1-260C-UNLIM	-40 to 125	2W	<a href="#">Samples</a>
TPS389012DSET	ACTIVE	WSO	DSE	6	250	Green (RoHS & no Sb/Br)	CU NIPDAU	Level-1-260C-UNLIM	-40 to 125	2W	<a href="#">Samples</a>
TPS389015DSER	ACTIVE	WSO	DSE	6	3000	Green (RoHS & no Sb/Br)	CU NIPDAU	Level-1-260C-UNLIM	-40 to 125	2X	<a href="#">Samples</a>
TPS389015DSET	ACTIVE	WSO	DSE	6	250	Green (RoHS & no Sb/Br)	CU NIPDAU	Level-1-260C-UNLIM	-40 to 125	2X	<a href="#">Samples</a>
TPS389018DSER	ACTIVE	WSO	DSE	6	3000	Green (RoHS & no Sb/Br)	CU NIPDAU	Level-1-260C-UNLIM	-40 to 125	2Y	<a href="#">Samples</a>
TPS389018DSET	ACTIVE	WSO	DSE	6	250	Green (RoHS & no Sb/Br)	CU NIPDAU	Level-1-260C-UNLIM	-40 to 125	2Y	<a href="#">Samples</a>
TPS389020DSER	ACTIVE	WSO	DSE	6	3000	Green (RoHS & no Sb/Br)	CU NIPDAU	Level-1-260C-UNLIM	-40 to 125	2Y	<a href="#">Samples</a>
TPS389020DSET	ACTIVE	WSO	DSE	6	250	Green (RoHS & no Sb/Br)	CU NIPDAU	Level-1-260C-UNLIM	-40 to 125	2Y	<a href="#">Samples</a>
TPS389025DSER	ACTIVE	WSO	DSE	6	3000	Green (RoHS & no Sb/Br)	CU NIPDAU	Level-1-260C-UNLIM	-40 to 125	2Z	<a href="#">Samples</a>
TPS389025DSET	ACTIVE	WSO	DSE	6	250	Green (RoHS & no Sb/Br)	CU NIPDAU	Level-1-260C-UNLIM	-40 to 125	2Z	<a href="#">Samples</a>
TPS389030DSER	ACTIVE	WSO	DSE	6	3000	Green (RoHS & no Sb/Br)	CU NIPDAU	Level-1-260C-UNLIM	-40 to 125	3A	<a href="#">Samples</a>
TPS389030DSET	ACTIVE	WSO	DSE	6	250	Green (RoHS & no Sb/Br)	CU NIPDAU	Level-1-260C-UNLIM	-40 to 125	3A	<a href="#">Samples</a>
TPS389033DSER	ACTIVE	WSO	DSE	6	3000	Green (RoHS & no Sb/Br)	CU NIPDAU	Level-1-260C-UNLIM	-40 to 125	3B	<a href="#">Samples</a>
TPS389033DSET	ACTIVE	WSO	DSE	6	250	Green (RoHS & no Sb/Br)	CU NIPDAU	Level-1-260C-UNLIM	-40 to 125	3B	<a href="#">Samples</a>

(1) The marketing status values are defined as follows:  
**ACTIVE:** Product device recommended for new designs.

---

**LIFEBUY:** TI has announced that the device will be discontinued, and a lifetime-buy period is in effect.

**NRND:** Not recommended for new designs. Device is in production to support existing customers, but TI does not recommend using this part in a new design.

**PREVIEW:** Device has been announced but is not in production. Samples may or may not be available.

**OBSELETE:** TI has discontinued the production of the device.

<sup>(2)</sup> Eco Plan - The planned eco-friendly classification: Pb-Free (RoHS), Pb-Free (RoHS Exempt), or Green (RoHS & no Sb/Br) - please check <http://www.ti.com/productcontent> for the latest availability information and additional product content details.

**TBD:** The Pb-Free/Green conversion plan has not been defined.

**Pb-Free (RoHS):** TI's terms "Lead-Free" or "Pb-Free" mean semiconductor products that are compatible with the current RoHS requirements for all 6 substances, including the requirement that lead not exceed 0.1% by weight in homogeneous materials. Where designed to be soldered at high temperatures, TI Pb-Free products are suitable for use in specified lead-free processes.

**Pb-Free (RoHS Exempt):** This component has a RoHS exemption for either 1) lead-based flip-chip solder bumps used between the die and package, or 2) lead-based die adhesive used between the die and leadframe. The component is otherwise considered Pb-Free (RoHS compatible) as defined above.

**Green (RoHS & no Sb/Br):** TI defines "Green" to mean Pb-Free (RoHS compatible), and free of Bromine (Br) and Antimony (Sb) based flame retardants (Br or Sb do not exceed 0.1% by weight in homogeneous material)

<sup>(3)</sup> MSL, Peak Temp. - The Moisture Sensitivity Level rating according to the JEDEC industry standard classifications, and peak solder temperature.

<sup>(4)</sup> There may be additional marking, which relates to the logo, the lot trace code information, or the environmental category on the device.

<sup>(5)</sup> Multiple Device Markings will be inside parentheses. Only one Device Marking contained in parentheses and separated by a "~" will appear on a device. If a line is indented then it is a continuation of the previous line and the two combined represent the entire Device Marking for that device.

<sup>(6)</sup> Lead/Ball Finish - Orderable Devices may have multiple material finish options. Finish options are separated by a vertical ruled line. Lead/Ball Finish values may wrap to two lines if the finish value exceeds the maximum column width.

**Important Information and Disclaimer:**The information provided on this page represents TI's knowledge and belief as of the date that it is provided. TI bases its knowledge and belief on information provided by third parties, and makes no representation or warranty as to the accuracy of such information. Efforts are underway to better integrate information from third parties. TI has taken and continues to take reasonable steps to provide representative and accurate information but may not have conducted destructive testing or chemical analysis on incoming materials and chemicals. TI and TI suppliers consider certain information to be proprietary, and thus CAS numbers and other limited information may not be available for release.

In no event shall TI's liability arising out of such information exceed the total purchase price of the TI part(s) at issue in this document sold by TI to Customer on an annual basis.

## TAPE AND REEL INFORMATION

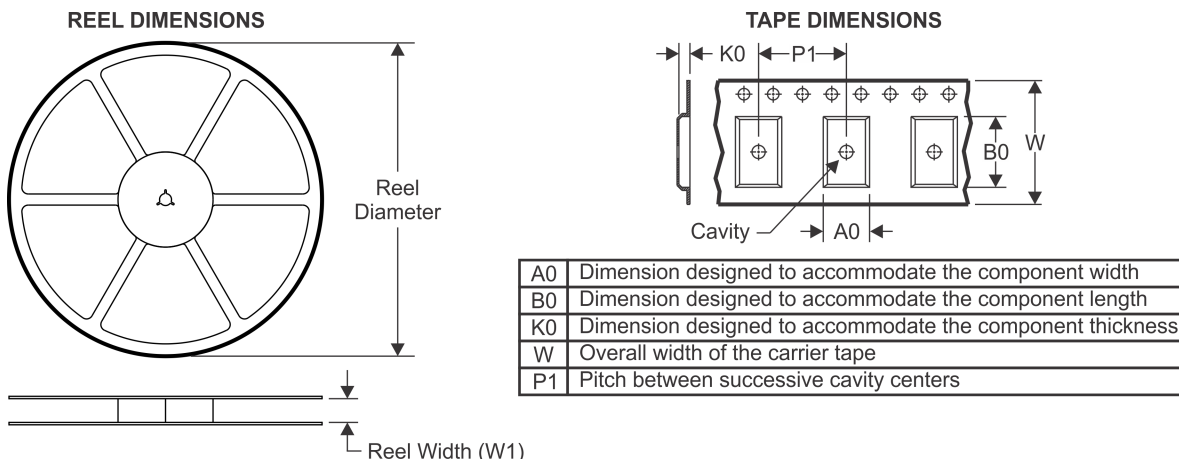

### QUADRANT ASSIGNMENTS FOR PIN 1 ORIENTATION IN TAPE



\*All dimensions are nominal

Device	Package Type	Package Drawing	Pins	SPQ	Reel Diameter (mm)	Reel Width W1 (mm)	A0 (mm)	B0 (mm)	K0 (mm)	P1 (mm)	W (mm)	Pin1 Quadrant
TPS389001DSER	WSO	DSE	6	3000	180.0	8.4	1.83	1.83	0.89	4.0	8.0	Q2
TPS389001DSET	WSO	DSE	6	250	180.0	8.4	1.83	1.83	0.89	4.0	8.0	Q2
TPS389012DSER	WSO	DSE	6	3000	180.0	8.4	1.83	1.83	0.89	4.0	8.0	Q2
TPS389012DSET	WSO	DSE	6	250	180.0	8.4	1.83	1.83	0.89	4.0	8.0	Q2
TPS389015DSER	WSO	DSE	6	3000	180.0	8.4	1.83	1.83	0.89	4.0	8.0	Q2
TPS389015DSET	WSO	DSE	6	250	180.0	8.4	1.83	1.83	0.89	4.0	8.0	Q2
TPS389018DSER	WSO	DSE	6	3000	180.0	8.4	1.83	1.83	0.89	4.0	8.0	Q2
TPS389018DSET	WSO	DSE	6	250	180.0	8.4	1.83	1.83	0.89	4.0	8.0	Q2
TPS389020DSER	WSO	DSE	6	3000	180.0	8.4	1.83	1.83	0.89	4.0	8.0	Q2
TPS389020DSET	WSO	DSE	6	250	180.0	8.4	1.83	1.83	0.89	4.0	8.0	Q2
TPS389025DSER	WSO	DSE	6	3000	180.0	8.4	1.83	1.83	0.89	4.0	8.0	Q2
TPS389025DSET	WSO	DSE	6	250	180.0	8.4	1.83	1.83	0.89	4.0	8.0	Q2
TPS389030DSER	WSO	DSE	6	3000	180.0	8.4	1.83	1.83	0.89	4.0	8.0	Q2
TPS389030DSET	WSO	DSE	6	250	180.0	8.4	1.83	1.83	0.89	4.0	8.0	Q2
TPS389033DSER	WSO	DSE	6	3000	180.0	8.4	1.83	1.83	0.89	4.0	8.0	Q2
TPS389033DSET	WSO	DSE	6	250	180.0	8.4	1.83	1.83	0.89	4.0	8.0	Q2

**TAPE AND REEL BOX DIMENSIONS**

\*All dimensions are nominal

Device	Package Type	Package Drawing	Pins	SPQ	Length (mm)	Width (mm)	Height (mm)
TPS389001DSER	WSON	DSE	6	3000	183.0	183.0	20.0
TPS389001DSET	WSON	DSE	6	250	183.0	183.0	20.0
TPS389012DSER	WSON	DSE	6	3000	183.0	183.0	20.0
TPS389012DSET	WSON	DSE	6	250	183.0	183.0	20.0
TPS389015DSER	WSON	DSE	6	3000	183.0	183.0	20.0
TPS389015DSET	WSON	DSE	6	250	183.0	183.0	20.0
TPS389018DSER	WSON	DSE	6	3000	183.0	183.0	20.0
TPS389018DSET	WSON	DSE	6	250	183.0	183.0	20.0
TPS389020DSER	WSON	DSE	6	3000	183.0	183.0	20.0
TPS389020DSET	WSON	DSE	6	250	183.0	183.0	20.0
TPS389025DSER	WSON	DSE	6	3000	183.0	183.0	20.0
TPS389025DSET	WSON	DSE	6	250	183.0	183.0	20.0
TPS389030DSER	WSON	DSE	6	3000	183.0	183.0	20.0
TPS389030DSET	WSON	DSE	6	250	183.0	183.0	20.0
TPS389033DSER	WSON	DSE	6	3000	183.0	183.0	20.0
TPS389033DSET	WSON	DSE	6	250	183.0	183.0	20.0

DSE (S-PDSO-N6)

PLASTIC SMALL OUTLINE

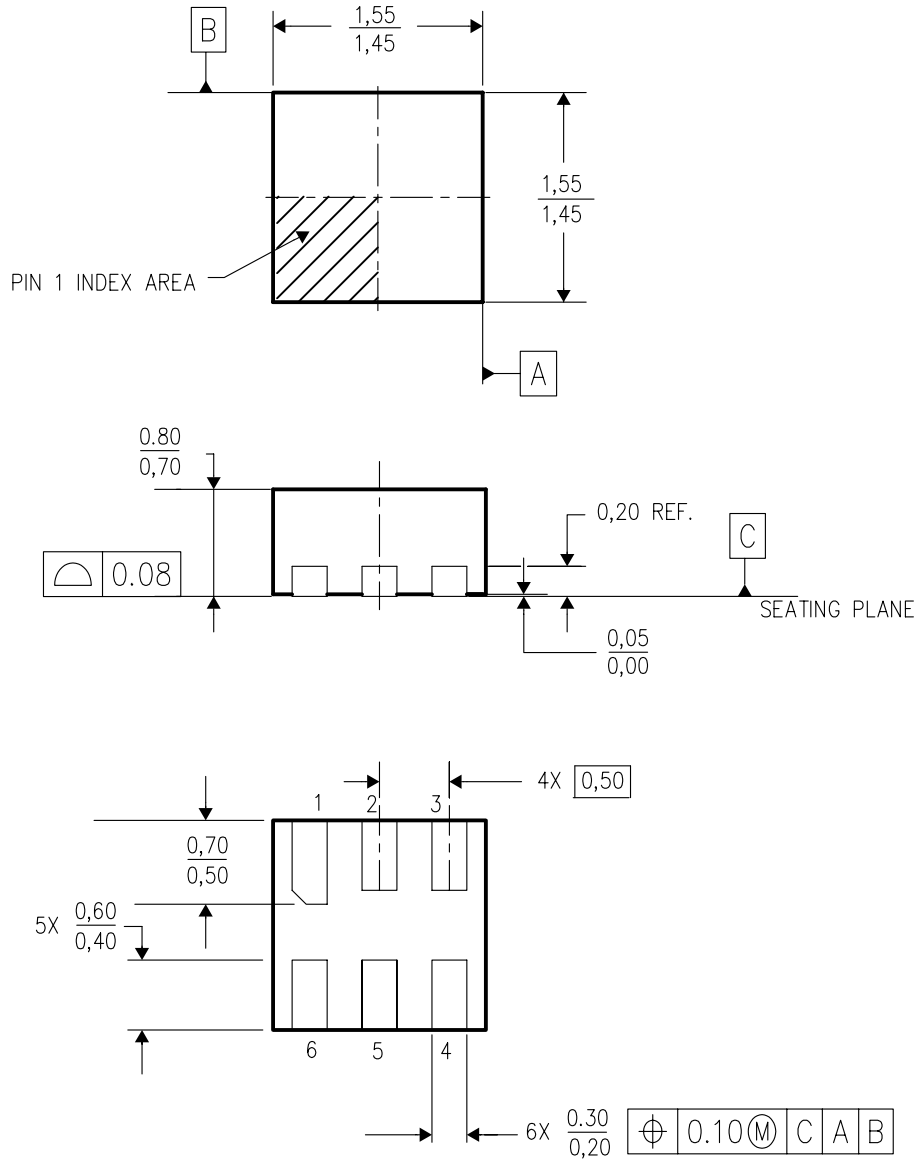

4207810/A 03/06

- NOTES:
- A. All linear dimensions are in millimeters.
  - B. This drawing is subject to change without notice.
  - C. Small Outline No-Lead (SON) package configuration.
  - D. This package is lead-free.

DSE (S-PWSON-N6)

PLASTIC SMALL OUTLINE NO-LEAD

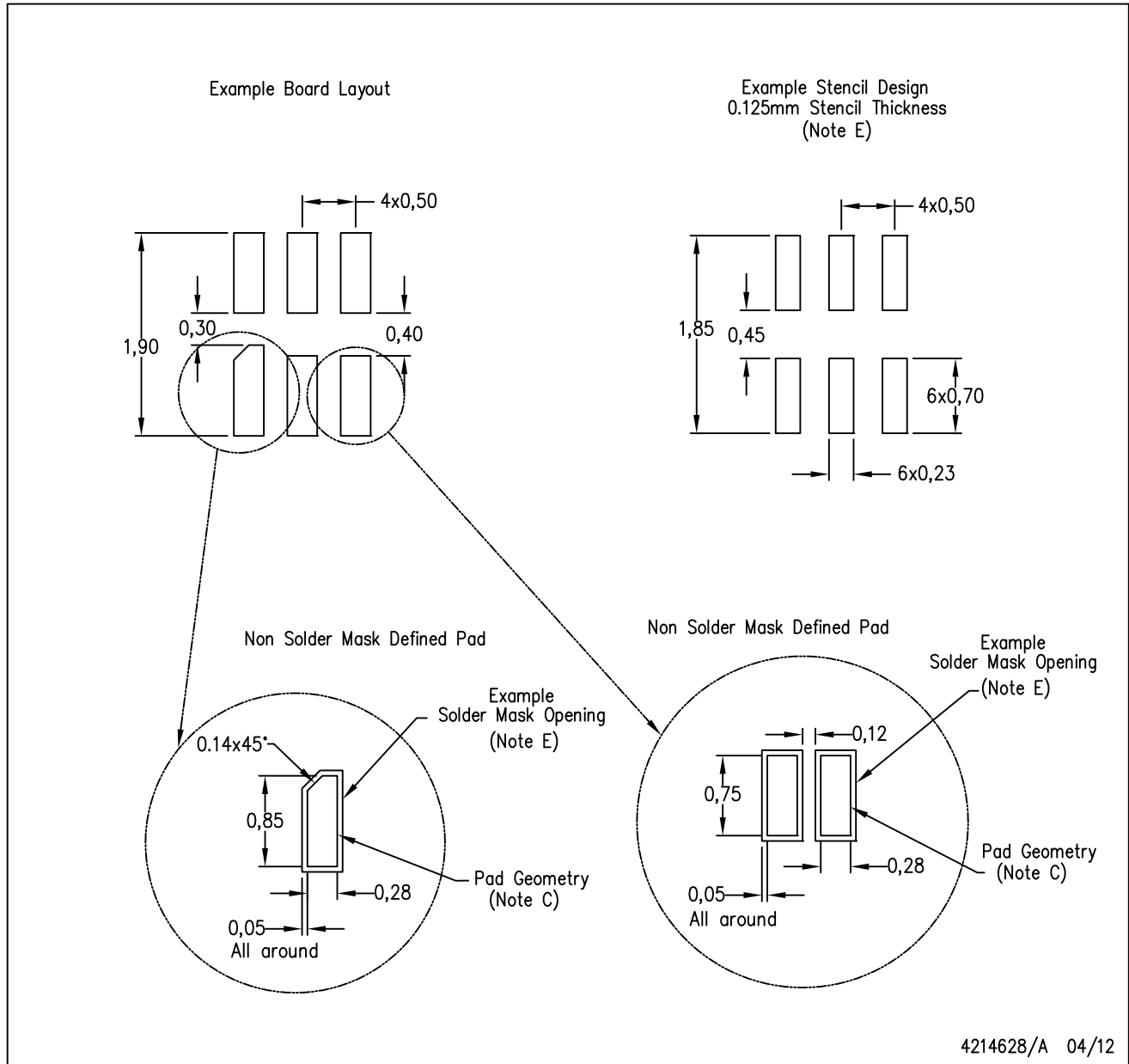

- NOTES:
- A. All linear dimensions are in millimeters.
  - B. This drawing is subject to change without notice.
  - C. Publication IPC-7351 is recommended for alternate designs.
  - D. Laser cutting apertures with trapezoidal walls and also rounding corners will offer better paste release. Customers should contact their board assembly site for stencil design recommendations. Refer to IPC 7525 for stencil design considerations.
  - E. Customers should contact their board fabrication site for solder mask tolerances.

## IMPORTANT NOTICE

Texas Instruments Incorporated (TI) reserves the right to make corrections, enhancements, improvements and other changes to its semiconductor products and services per JESD46, latest issue, and to discontinue any product or service per JESD48, latest issue. Buyers should obtain the latest relevant information before placing orders and should verify that such information is current and complete.

TI's published terms of sale for semiconductor products (<http://www.ti.com/sc/docs/stdterms.htm>) apply to the sale of packaged integrated circuit products that TI has qualified and released to market. Additional terms may apply to the use or sale of other types of TI products and services.

Reproduction of significant portions of TI information in TI data sheets is permissible only if reproduction is without alteration and is accompanied by all associated warranties, conditions, limitations, and notices. TI is not responsible or liable for such reproduced documentation. Information of third parties may be subject to additional restrictions. Resale of TI products or services with statements different from or beyond the parameters stated by TI for that product or service voids all express and any implied warranties for the associated TI product or service and is an unfair and deceptive business practice. TI is not responsible or liable for any such statements.

Buyers and others who are developing systems that incorporate TI products (collectively, "Designers") understand and agree that Designers remain responsible for using their independent analysis, evaluation and judgment in designing their applications and that Designers have full and exclusive responsibility to assure the safety of Designers' applications and compliance of their applications (and of all TI products used in or for Designers' applications) with all applicable regulations, laws and other applicable requirements. Designer represents that, with respect to their applications, Designer has all the necessary expertise to create and implement safeguards that (1) anticipate dangerous consequences of failures, (2) monitor failures and their consequences, and (3) lessen the likelihood of failures that might cause harm and take appropriate actions. Designer agrees that prior to using or distributing any applications that include TI products, Designer will thoroughly test such applications and the functionality of such TI products as used in such applications.

TI's provision of technical, application or other design advice, quality characterization, reliability data or other services or information, including, but not limited to, reference designs and materials relating to evaluation modules, (collectively, "TI Resources") are intended to assist designers who are developing applications that incorporate TI products; by downloading, accessing or using TI Resources in any way, Designer (individually or, if Designer is acting on behalf of a company, Designer's company) agrees to use any particular TI Resource solely for this purpose and subject to the terms of this Notice.

TI's provision of TI Resources does not expand or otherwise alter TI's applicable published warranties or warranty disclaimers for TI products, and no additional obligations or liabilities arise from TI providing such TI Resources. TI reserves the right to make corrections, enhancements, improvements and other changes to its TI Resources. TI has not conducted any testing other than that specifically described in the published documentation for a particular TI Resource.

Designer is authorized to use, copy and modify any individual TI Resource only in connection with the development of applications that include the TI product(s) identified in such TI Resource. NO OTHER LICENSE, EXPRESS OR IMPLIED, BY ESTOPPEL OR OTHERWISE TO ANY OTHER TI INTELLECTUAL PROPERTY RIGHT, AND NO LICENSE TO ANY TECHNOLOGY OR INTELLECTUAL PROPERTY RIGHT OF TI OR ANY THIRD PARTY IS GRANTED HEREIN, including but not limited to any patent right, copyright, mask work right, or other intellectual property right relating to any combination, machine, or process in which TI products or services are used. Information regarding or referencing third-party products or services does not constitute a license to use such products or services, or a warranty or endorsement thereof. Use of TI Resources may require a license from a third party under the patents or other intellectual property of the third party, or a license from TI under the patents or other intellectual property of TI.

TI RESOURCES ARE PROVIDED "AS IS" AND WITH ALL FAULTS. TI DISCLAIMS ALL OTHER WARRANTIES OR REPRESENTATIONS, EXPRESS OR IMPLIED, REGARDING RESOURCES OR USE THEREOF, INCLUDING BUT NOT LIMITED TO ACCURACY OR COMPLETENESS, TITLE, ANY EPIDEMIC FAILURE WARRANTY AND ANY IMPLIED WARRANTIES OF MERCHANTABILITY, FITNESS FOR A PARTICULAR PURPOSE, AND NON-INFRINGEMENT OF ANY THIRD PARTY INTELLECTUAL PROPERTY RIGHTS. TI SHALL NOT BE LIABLE FOR AND SHALL NOT DEFEND OR INDEMNIFY DESIGNER AGAINST ANY CLAIM, INCLUDING BUT NOT LIMITED TO ANY INFRINGEMENT CLAIM THAT RELATES TO OR IS BASED ON ANY COMBINATION OF PRODUCTS EVEN IF DESCRIBED IN TI RESOURCES OR OTHERWISE. IN NO EVENT SHALL TI BE LIABLE FOR ANY ACTUAL, DIRECT, SPECIAL, COLLATERAL, INDIRECT, PUNITIVE, INCIDENTAL, CONSEQUENTIAL OR EXEMPLARY DAMAGES IN CONNECTION WITH OR ARISING OUT OF TI RESOURCES OR USE THEREOF, AND REGARDLESS OF WHETHER TI HAS BEEN ADVISED OF THE POSSIBILITY OF SUCH DAMAGES.

Unless TI has explicitly designated an individual product as meeting the requirements of a particular industry standard (e.g., ISO/TS 16949 and ISO 26262), TI is not responsible for any failure to meet such industry standard requirements.

Where TI specifically promotes products as facilitating functional safety or as compliant with industry functional safety standards, such products are intended to help enable customers to design and create their own applications that meet applicable functional safety standards and requirements. Using products in an application does not by itself establish any safety features in the application. Designers must ensure compliance with safety-related requirements and standards applicable to their applications. Designer may not use any TI products in life-critical medical equipment unless authorized officers of the parties have executed a special contract specifically governing such use. Life-critical medical equipment is medical equipment where failure of such equipment would cause serious bodily injury or death (e.g., life support, pacemakers, defibrillators, heart pumps, neurostimulators, and implantables). Such equipment includes, without limitation, all medical devices identified by the U.S. Food and Drug Administration as Class III devices and equivalent classifications outside the U.S.

TI may expressly designate certain products as completing a particular qualification (e.g., Q100, Military Grade, or Enhanced Product). Designers agree that it has the necessary expertise to select the product with the appropriate qualification designation for their applications and that proper product selection is at Designers' own risk. Designers are solely responsible for compliance with all legal and regulatory requirements in connection with such selection.

Designer will fully indemnify TI and its representatives against any damages, costs, losses, and/or liabilities arising out of Designer's non-compliance with the terms and provisions of this Notice.

## Looking for pricing, stock, or lifecycle information?

Click below to explore more details on WIN SOURCE:

 [View TPS389033DSET](#) on WIN SOURCE

 [Texas Instruments](#) Information

## Optimize Your Supply Chain with WIN SOURCE Solutions

-  Global Sourcing Solution
-  Obsolete Management
-  Cost Control Management
-  Shortage Management
-  Alternative Solution
-  Excess Inventory Management