



**THE DATASHEET OF
LT1011AIS8#TRPBF**



FEATURES

- Pin Compatible with LM111 Series Devices
- *Guaranteed* Max 0.5mV Input Offset Voltage
- *Guaranteed* Max 25nA Input Bias Current
- *Guaranteed* Max 3nA Input Offset Current
- *Guaranteed* Max 250ns Response Time
- *Guaranteed* Min 200,000 Voltage Gain
- 50mA Output Current Source or Sink
- $\pm 30\text{V}$ Differential Input Voltage
- Fully Specified for Single 5V Operation
- Available in 8-Lead PDIP and SO Packages

APPLICATIONS

- SAR A/D Converters
- Voltage-to-Frequency Converters
- Precision RC Oscillator
- Peak Detector
- Motor Speed Control
- Pulse Generator
- Relay/Lamp Driver

DESCRIPTION

The **LT[®]1011** is a general purpose comparator with significantly better input characteristics than the LM111. Although pin compatible with the LM111, it offers four times lower bias current, six times lower offset voltage and five times higher voltage gain. Offset voltage drift, a previously unspecified parameter, is guaranteed at $15\mu\text{V}/^\circ\text{C}$. Additionally, the supply current is lower by a factor of two with no loss in speed. The LT1011 is several times faster than the LM111 when subjected to large overdrive conditions. It is also fully specified for DC parameters and response time when operating on a single 5V supply. The LT1011 retains all the versatile features of the LM111, including single 3V to $\pm 18\text{V}$ supply operation, and a floating transistor output with 50mA source/sink capability. It can drive loads referenced to ground, negative supply or positive supply, and is specified up to 50V between V^- and the collector output. A differential input voltage up to the full supply voltage is allowed, even with $\pm 18\text{V}$ supplies, enabling the inputs to be clamped to the supplies with simple diode clamps.

LT, LT, LTC, LTM, Linear Technology and the Linear logo are registered trademarks of Linear Technology Corporation. All other trademarks are the property of their respective owners.

TYPICAL APPLICATION

10 μs 12-Bit A/D Converter

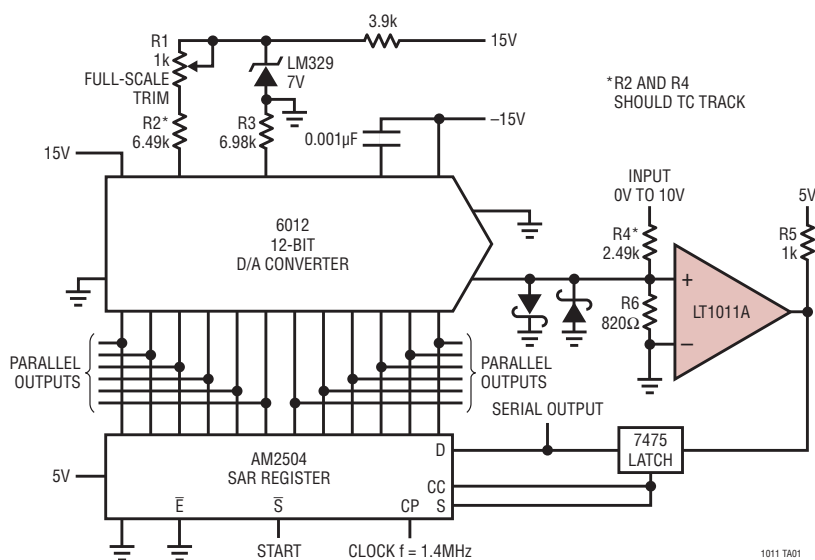

Response Time vs Overdrive

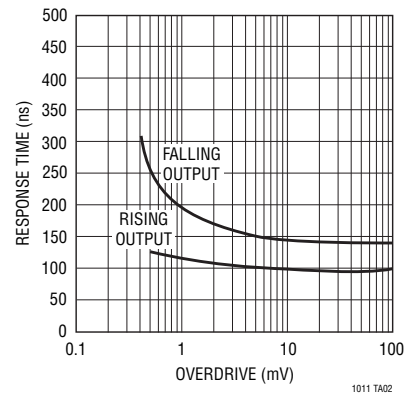

1011 TA02

LT1011/LT1011A

ABSOLUTE MAXIMUM RATINGS

(Note 1)

Supply Voltage (Pin 8 to Pin 4)	36V
Output to Negative Supply (Pin 7 to Pin 4)	
LT1011AC, LT1011C.....	40V
LT1011AI, LT1011I.....	40V
LT1011AM, LT1011M (OBSOLETE).....	50V
Ground to Negative Supply (Pin 1 to Pin 4)	30V
Differential Input Voltage	±36V
Voltage at STROBE Pin (Pin 6 to Pin 8).....	5V

Input Voltage (Note 2).....	Equal to Supplies
Output Short-Circuit Duration	10 sec
Operating Temperature Range (Note 3)	
LT1011AC, LT1011C.....	0°C to 70°C
LT1011AI, LT1011I.....	-40°C to 85°C
LT1011AM, LT1011M (OBSOLETE).....	-55°C to 125°C
Storage Temperature Range	-65°C to 150°C
Lead Temperature (Soldering, 10 sec).....	300°C

PIN CONFIGURATION

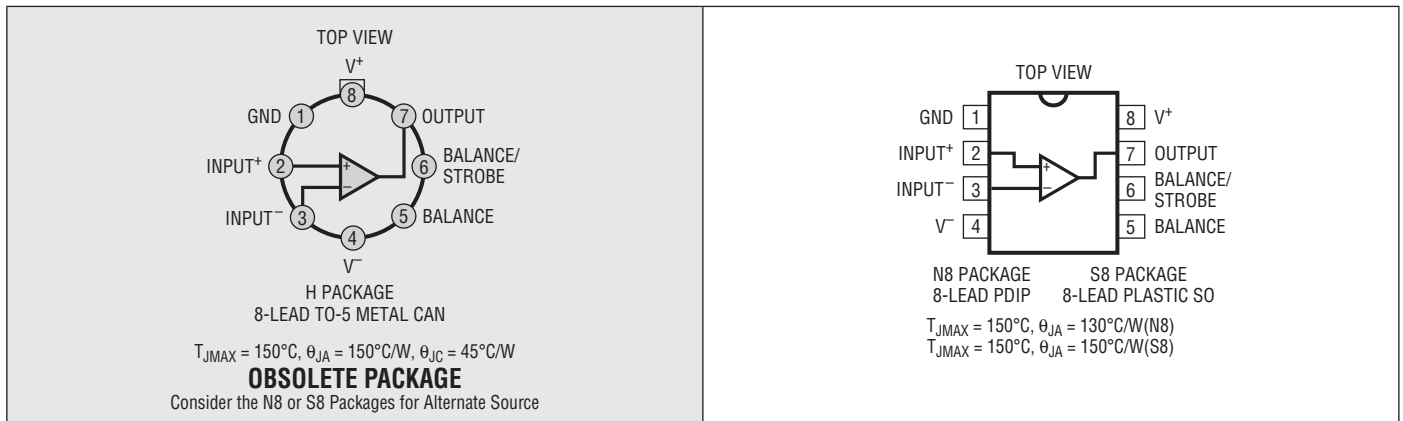

ORDER INFORMATION

LEAD FREE FINISH	TAPE AND REEL	PART MARKING*	PACKAGE DESCRIPTION	TEMPERATURE RANGE
LT1011ACN8#PBF	N/A	LT1011	8-Lead Plastic DIP	0°C to 70°C
LT1011CN8#PBF	N/A	LT1011	8-Lead Plastic DIP	0°C to 70°C
LT1011AIS8#PBF	LT1011AIS8#TRPBF	1011AI	8-Lead Plastic SO	-40°C to 85°C
LT1011CS8#PBF	LT1011CS8#TRPBF	1011	8-Lead Plastic SO	0°C to 70°C
LT1011IS8#PBF	LT1011IS8#TRPBF	1011I	8-Lead Plastic SO	-40°C to 85°C
OBSOLETE PACKAGES				
LT1011ACH#PBF	N/A		8-Lead TO-5 Metal Can	-55°C to 125°C
LT1011CH#PBF	N/A		8-Lead TO-5 Metal Can	-55°C to 125°C
LT1011AMH#PBF	N/A		8-Lead TO-5 Metal Can	-55°C to 125°C
LT1011MH#PBF	N/A		8-Lead TO-5 Metal Can	-55°C to 125°C
LT1011ACJ8#PBF	N/A		8-Lead CERDIP	-55°C to 125°C
LT1011CJ8#PBF	N/A		8-Lead CERDIP	-55°C to 125°C
LT1011AMJ8#PBF	N/A		8-Lead CERDIP	-55°C to 125°C
LT1011MJ8#PBF	N/A		8-Lead CERDIP	-55°C to 125°C

Consult LTC Marketing for parts specified with wider operating temperature ranges. *The temperature grade is identified by a label on the shipping container. Consult LTC Marketing for information on nonstandard lead based finish parts.

For more information on lead free part marking, go to: <http://www.linear.com/leadfree/>

For more information on tape and reel specifications, go to: <http://www.linear.com/tapeandreeel/>

LT1011/LT1011A

ELECTRICAL CHARACTERISTICS The ● denotes the specifications which apply over the full operating temperature range, otherwise specifications are at $T_A = 25^\circ\text{C}$. $V_S = \pm 15\text{V}$, $V_{CM} = 0\text{V}$, $R_S = 0\Omega$, $V_{GND} = -15\text{V}$, output at pin 7 unless otherwise noted.

SYMBOL	PARAMETER	CONDITIONS	LT1011AC/AI/AM			LT1011C/I/M			UNITS
			MIN	TYP	MAX	MIN	TYP	MAX	
V_{OS}	Input Offset Voltage	(Note 4)	●	0.3	0.5	0.6	1.5	mV	
	*Input Offset Voltage	$R_S \leq 50\text{k}$ (Note 5)	●		1	3	3	mV	
I_{OS}	*Input Offset Current	(Note 5)	●	0.2	3	0.2	4	nA	
					5	6	6	nA	
I_B	Input Bias Current	(Note 4)		15	25	20	50	nA	
	*Input Bias Current	(Note 5)	●	20	35	25	65	nA	
					50	80	80	nA	
$\frac{\Delta V_{OS}}{\Delta T}$	Input Offset Voltage Drift (Note 6)	$T_{MIN} \leq T \leq T_{MAX}$	●	4	15	4	25	$\mu\text{V}/^\circ\text{C}$	
A_{VOL}	*Large-Signal Voltage Gain	$R_L = 1\text{k}$ Connected to 15V, $-10\text{V} \leq V_{OUT} \leq 14.5\text{V}$		200	500	200	500	V/mV	
		$R_L = 500\Omega$ Connected to 5V, $V_S = \text{Single } 5\text{V}$, $V_{GND} = 0\text{V}$, $0.5\text{V} \leq V_{OUT} \leq 4.5\text{V}$		50	300	50	300	V/mV	
CMRR	Common Mode Rejection Ratio			94	115	90	115	dB	
	*Input Voltage Range (Note 9)	$V_S = \pm 15\text{V}$	●	-14.5	13	-14.5	13	V	
		$V_S = \text{Single } 5\text{V}$	●	0.5	3	0.5	3	V	
t_D	*Response Time	(Note 7)		150	250	150	250	ns	
V_{OL}	*Output Saturation Voltage, $V_{GND} = 0$	$V_{IN} = -5\text{mV}$, $I_{SINK} = 8\text{mA}$, $T_J \leq 100^\circ\text{C}$	●	0.25	0.4	0.25	0.4	V	
		$V_{IN} = -5\text{mV}$, $I_{SINK} = 8\text{mA}$	●	0.25	0.45	0.25	0.45	V	
		$V_{IN} = -5\text{mV}$, $I_{SINK} = 50\text{mA}$	●	0.7	1.5	0.7	1.5	V	
	*Output Leakage Current	$V_{IN} = 5\text{mV}$, $V_{GND} = -15\text{V}$, $V_{OUT} = 20\text{V}$	●	0.2	10	0.2	10	nA	
					500	500	500	nA	
	*Positive Supply Current	$V_{GND} = 0$		3.2	4	3.2	4	mA	
	*Negative Supply Current	$V_{GND} = 0$		1.7	2.5	1.7	2.5	mA	
	*Strobe Current (Note 8)	Minimum to Ensure Output Transistor is Off, $V_{GND} = 0$		500		500		μA	
	Input Capacitance			6		6		pF	

*Indicates parameters which are guaranteed for all supply voltages, including a single 5V supply. See Note 5.

Note 1: Stresses beyond those listed under Absolute Maximum Ratings may cause permanent damage to the device. Exposure to any Absolute Maximum Rating condition for extended periods may affect device reliability and lifetime.

Note 2: Inputs may be clamped to supplies with diodes so that maximum input voltage actually exceeds supply voltage by one diode drop. See Input Protection in the Applications Information section.

Note 3: $T_{JMAX} = 150^\circ\text{C}$.

Note 4: Output is sinking 1.5mA with $V_{OUT} = 0\text{V}$.

Note 5: These specifications apply for all supply voltages from a single 5V to $\pm 15\text{V}$, the entire input voltage range, and for both high and low output states. The high state is $I_{SINK} = 100\mu\text{A}$, $V_{OUT} = (V^+ - 1\text{V})$ and the low state is $I_{SINK} = 8\text{mA}$, $V_{OUT} = 0.8\text{V}$. Therefore, this specification

defines a worst-case error band that includes effects due to common mode signals, voltage gain and output load.

Note 6: Drift is calculated by dividing the offset voltage difference measured at min and max temperatures by the temperature difference.

Note 7: Response time is measured with a 100mV step and 5mV overdrive. The output load is a 500 Ω resistor tied to 5V. Time measurement is taken when the output crosses 1.4V.

Note 8: Do not short the STROBE pin to ground. It should be current driven at 3mA to 5mA for the shortest strobe time. Currents as low as 500 μA will strobe the LT1011A if speed is not important. External leakage on the STROBE pin in excess of 0.2 μA when the strobe is "off" can cause offset voltage shifts.

Note 9: See graph "Input Offset Voltage vs Common Mode Voltage."

TYPICAL PERFORMANCE CHARACTERISTICS

Input Bias Current

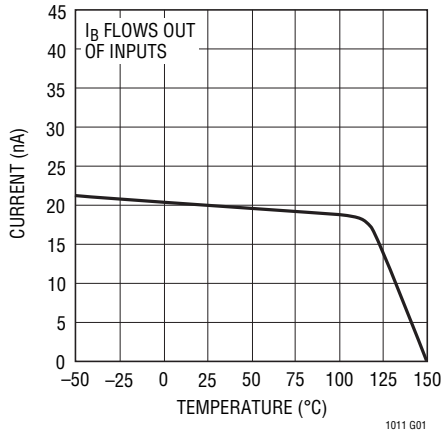

Input Offset Current

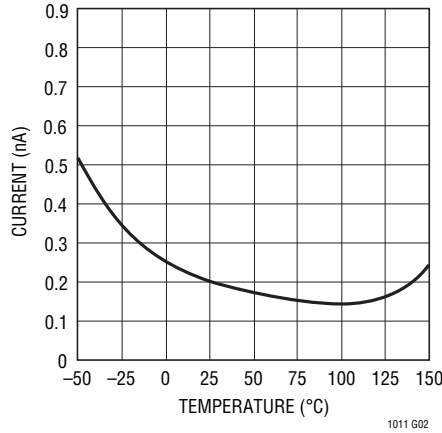

Worst-Case Offset Error

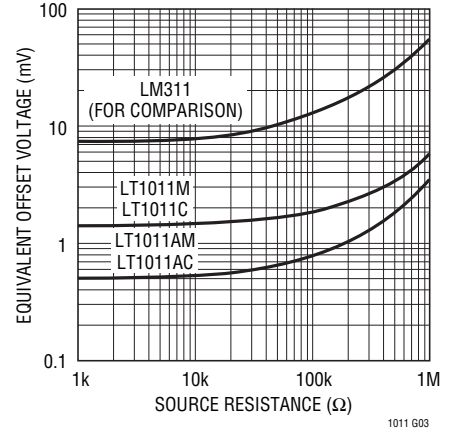

Input Characteristics*

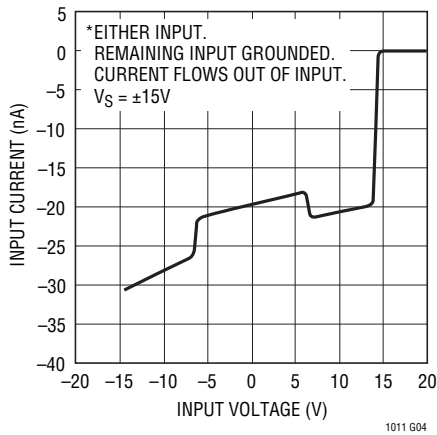

Common Mode Limits

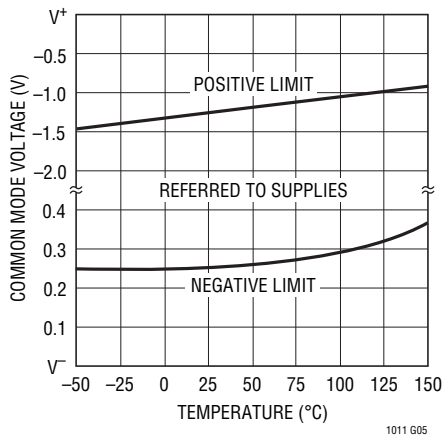

Transfer Function (Gain)

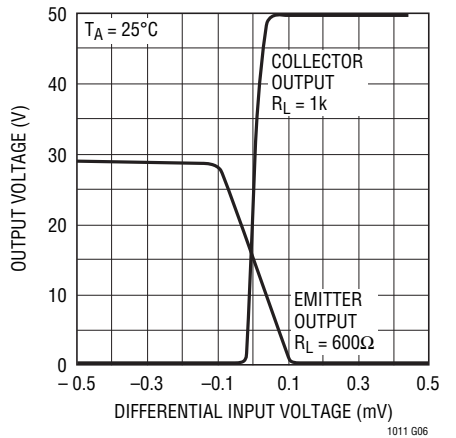

Response Time—Collector Output

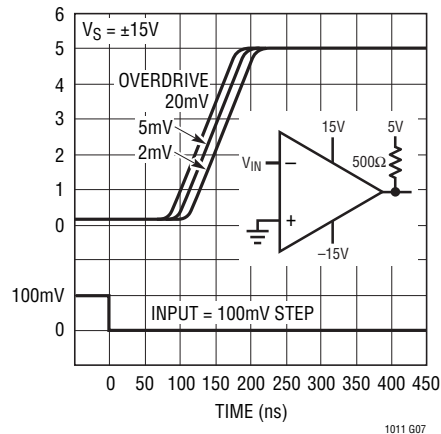

Response Time—Collector Output

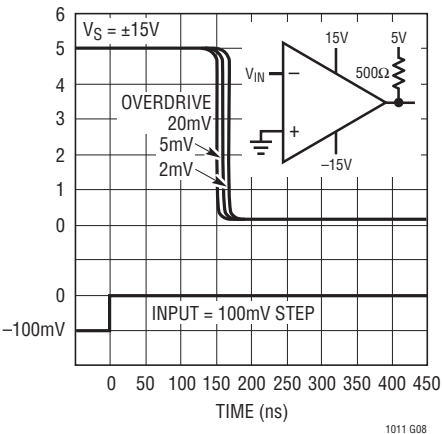

Collector Output Saturation Voltage

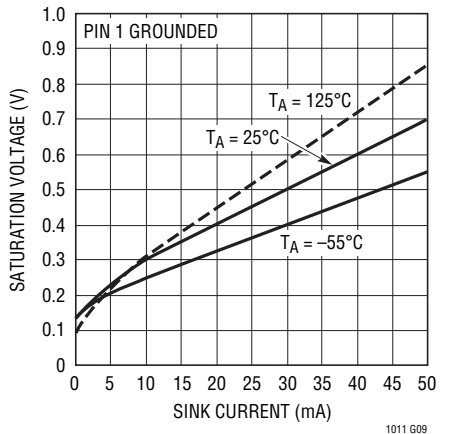

TYPICAL PERFORMANCE CHARACTERISTICS

Response Time Using GND Pin as Output

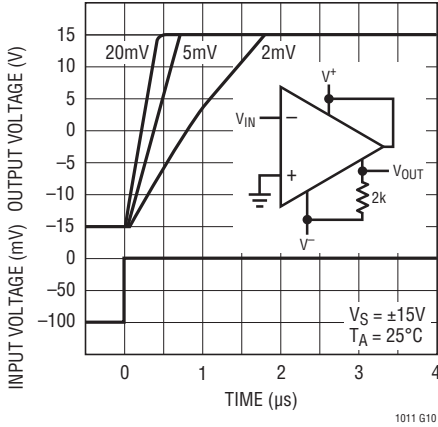

Response Time Using GND Pin as Output

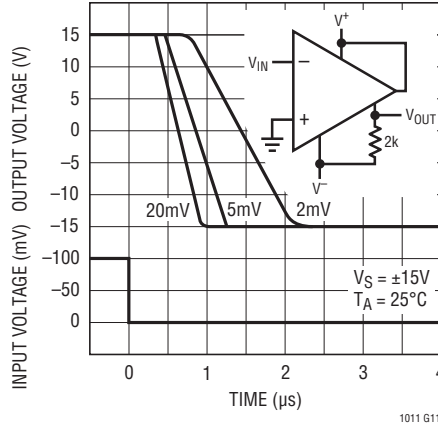

Output Limiting Characteristics*

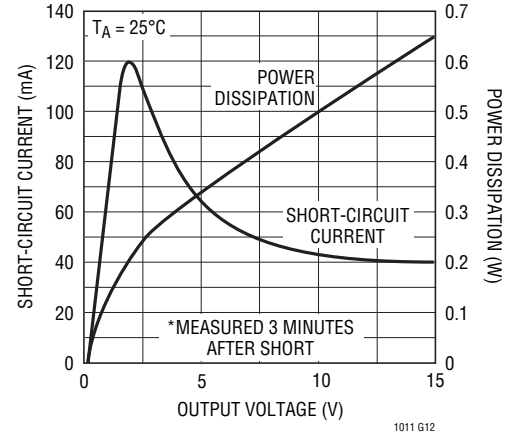

Supply Current vs Supply Voltage

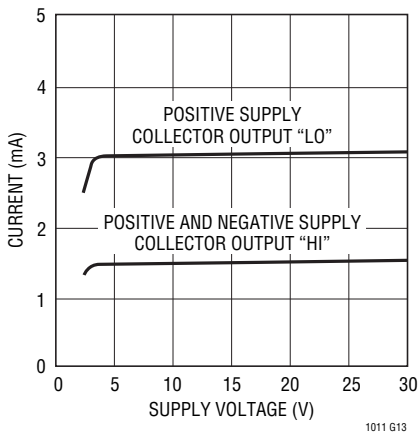

Supply Current vs Temperature

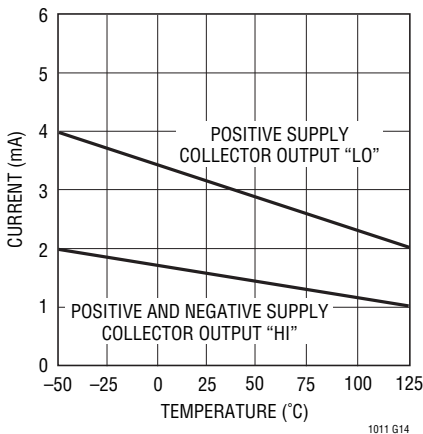

Output Leakage Current

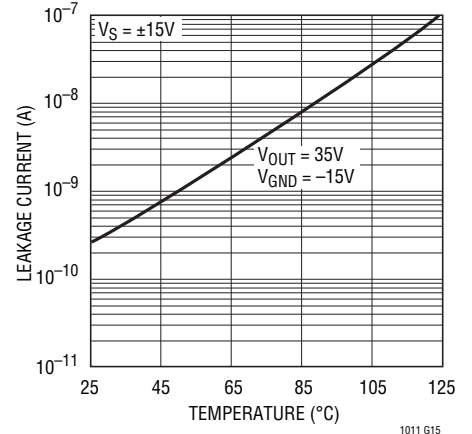

Output Saturation—Ground Output

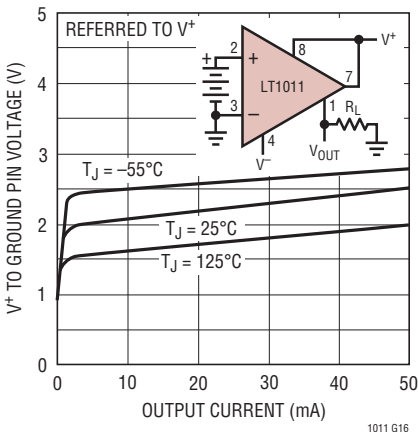

Output Saturation Voltage

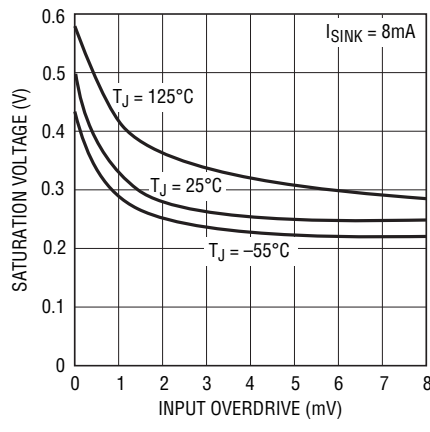

Response Time vs Input Step Size

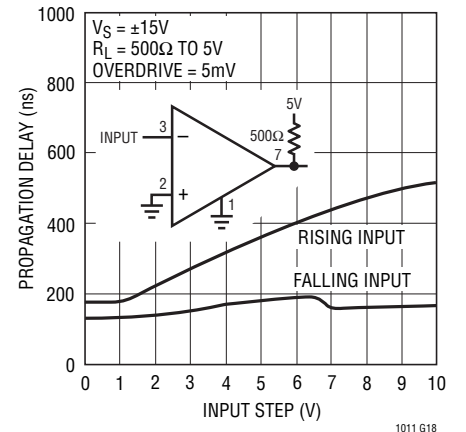

TYPICAL PERFORMANCE CHARACTERISTICS

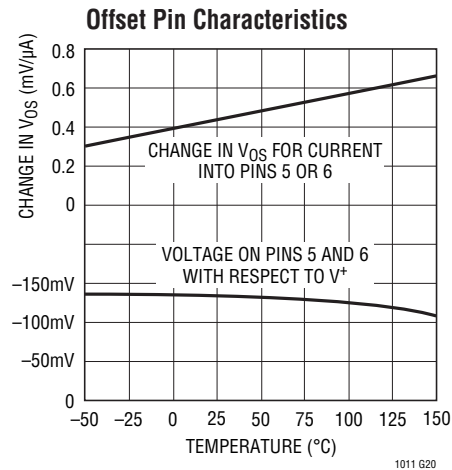
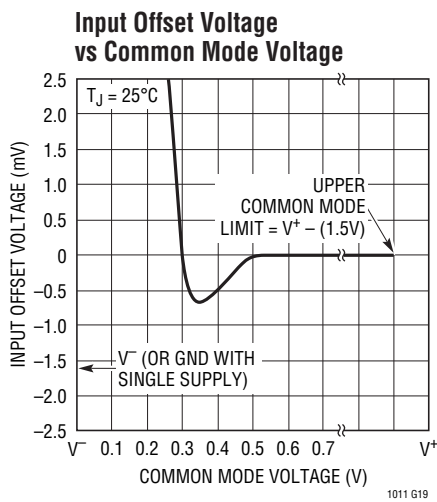

PIN FUNCTIONS

GND (PIN 1): Ground.

INPUT+ (PIN 2): Non-Inverting Input of Comparator

INPUT- (PIN 3): Inverting Input of Comparator

V^- (PIN 4): Negative Supply Voltage

OUT (PIN 7): Open-Collector Output of Comparator

BALANCE (PIN 5): Balance Input. This input can be used to adjust the input voltage offset or to add hysteresis. If offset balancing or hysteresis is not used, the BALANCE pins should be connected together with a 0.1 μF capacitor.

BALANCE/STROBE (PIN 6): Strobe Input Pin. Using this pin, the output transistor can be forced to an “off” state, giving a “hi” output at the collector (Pin 7). This input can be used to adjust the input voltage offset or used to add hysteresis. If offset balancing or hysteresis is not used, the BALANCE pins should be connected together with a 0.1 μF capacitor.

V^+ (PIN 8): Positive Supply Voltage

APPLICATIONS INFORMATION

Preventing Oscillation Problems

Oscillation problems in comparators are nearly always caused by stray capacitance between the output and inputs or between the output and other sensitive pins on the comparator. This is especially true with high gain bandwidth comparators like the LT1011, which are designed for fast switching with millivolt input signals. The gain bandwidth product of the LT1011 is over 10GHz. Oscillation problems tend to occur at frequencies around 5MHz, where the LT1011 has a gain of ≈ 2000 . This implies that attenuation of output signals must be at least 2000:1 at 5MHz as measured at the inputs. If the source impedance is $1\text{k}\Omega$, the effective stray capacitance between output and input must have a reactance of more than $(2000)(1\text{k}\Omega) = 2\text{M}\Omega$, or less than 0.02pF . The actual interlead capacitance between input and output pins on the LT1011 is less than 0.002pF when cut to printed circuit mount length. Additional stray capacitance due to printed circuit traces must be minimized by routing the output trace directly away from input lines and, if possible, running ground traces next to input traces to provide shielding. Additional steps to ensure oscillation-free operation are:

1. Bypass the STROBE/BALANCE pins with a $0.01\mu\text{F}$ capacitor connected from Pin 5 to Pin 6. This eliminates stray capacitive feedback from the output to the BALANCE pins, which are nearly as sensitive as the inputs.
2. Bypass the negative supply (Pin 4) with a $0.1\mu\text{F}$ ceramic capacitor close to the comparator. $0.1\mu\text{F}$ can also be used for the positive supply (Pin 8) if the pull-up load is tied to a separate supply. When the pull-up load is tied directly to Pin 8, use a $2\mu\text{F}$ solid tantalum bypass capacitor.
3. Bypass any slow moving or DC input with a capacitor ($\geq 0.01\mu\text{F}$) close to the comparator to reduce high frequency source impedance.
4. Keep resistive source impedance as low as possible. If a resistor is added in series with one input to balance source impedances for DC accuracy, bypass it with a capacitor. The low input bias current of the LT1011 usually eliminates any need for source resistance balancing. A $5\text{k}\Omega$ imbalance, for instance, will create only 0.25mV DC offset.
5. Use hysteresis. This consists of shifting the input offset voltage of the comparator when the output changes state. Hysteresis forces the comparator to move quickly through its linear region, eliminating oscillations by "overdriving" the comparator under all input conditions. Hysteresis may be either AC or DC. AC techniques do not shift the apparent offset voltage of the comparator, but require a *minimum* input signal slew rate to be effective. DC hysteresis works for all input slew rates, but creates a shift in offset voltage dependent on the previous condition of the input signal. The circuit shown in Figure 1 is an excellent compromise between AC and DC hysteresis.

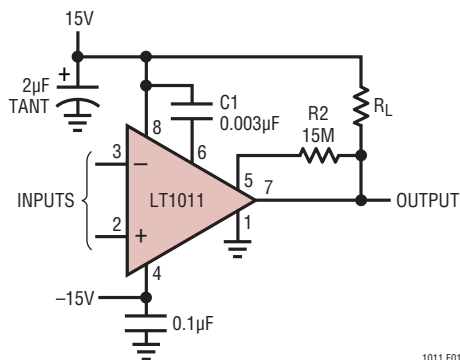

Figure 1. Comparator with Hysteresis

1011 F01

APPLICATIONS INFORMATION

This circuit is especially useful for general purpose comparator applications because it does not force any signals directly back onto the input signal source. Instead, it takes advantage of the unique properties of the BALANCE pins to provide extremely fast, clean output switching even with low frequency input signals in the millivolt range. The 0.003 μ F capacitor from Pin 6 to Pin 8 generates AC hysteresis because the voltage on the BALANCE pins shifts slightly, depending on the state of the output. Both pins move about 4mV. If one pin (6) is bypassed, AC hysteresis is created. It is only a few millivolts referred to the inputs, but is sufficient to switch the output at nearly the maximum speed of which the comparator is capable. To prevent problems from low values of input slew rate, a slight amount of DC hysteresis is also used. The sensitivity of the BALANCE pins to current is about 0.5mV input referred offset for each microampere of BALANCE pin current. The 15M resistor tied from OUTPUT to Pin 5 generates 0.5mV DC hysteresis. The combination of AC and DC hysteresis creates clean oscillation-free switching with very small input errors. Figure 2 plots input referred error versus switching frequency for the circuit as shown.

Note that at low frequencies, the error is simply the DC hysteresis, while at high frequencies, an additional error is created by the AC hysteresis. The high frequency error can be reduced by reducing C_H, but lower values may not provide clean switching with very low slew rate input signals.

Input Protection

The inputs to the LT1011 are particularly suited to general purpose comparator applications because large differential and/or common mode voltages can be tolerated without damage to the comparator. Either or both inputs can be raised 40V above the negative supply, *independent of the positive supply voltage*. Internal forward biased diodes will conduct when the inputs are taken below the negative supply. In this condition, input current must be limited to 1mA. If very large (fault) input voltages must be accommodated, series resistors and clamp diodes should be used (see Figure 3).

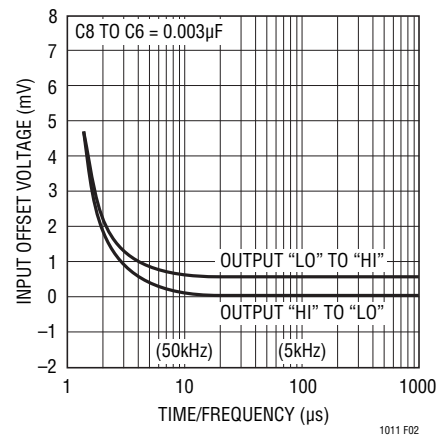

Figure 2. Input Offset Voltage vs Time to Last Transition

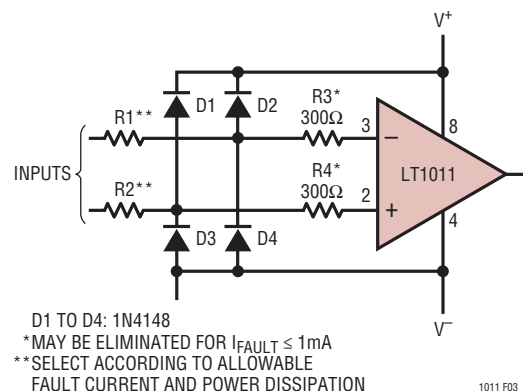

Figure 3. Limiting Fault Input Currents

APPLICATIONS INFORMATION

The input resistors should limit fault current to a reasonable value (0.1mA to 20mA). Power dissipation in the resistors must be considered for continuous faults, especially when the LT1011 supplies are off. One final caution: lightly loaded supplies may be forced to higher voltages by large fault currents flowing through D1-D4.

R3 and R4 limit input current to the LT1011 to less than 1mA when the input signals are held below V^- . They may be eliminated if R1 and R2 are large enough to limit fault current to less than 1mA.

Input Slew Rate Limitations

The response time of a comparator is typically measured with a 100mV step and a 5mV to 10mV overdrive. Unfortunately, this does not simulate many real world situations where the step size is typically much larger and overdrive can be significantly less. In the case of the LT1011, step size is important because the slew rate of internal nodes will limit response time for input step sizes larger than 1V. At 5V step size, for instance, response time increases from 150ns to 360ns. See the curve “Response Time vs Input Step Size for more detail.

If response time is critical and large input signals are expected, clamp diodes across the inputs are recommended. The slew rate limitation can also affect performance when differential input voltage is low, but both inputs must slew quickly. Maximum suggested common mode slew rate is 10V/ μ s.

Strobing

The LT1011 can be strobed by pulling current out of the STROBE pin. The output transistor is forced to an “off” state, giving a “hi” output at the collector (Pin 7). Currents as low as 250 μ A will cause strobing, but at low strobe currents, strobe delay will be 200ns to 300ns. If strobe current is increased to 3mA, strobe delay drops to about 60ns. The voltage at the STROBE pin is about 150mV below V^+ at zero strobe current and about 2V below V^+ for 3mA strobe current. *Do not ground the STROBE pin. It must be current driven.* Figure 4 shows a typical strobe circuit.

Note that there is no bypass capacitor between Pins 5 and 6. This maximizes strobe speed, but leaves the comparator more sensitive to oscillation problems for slow, low

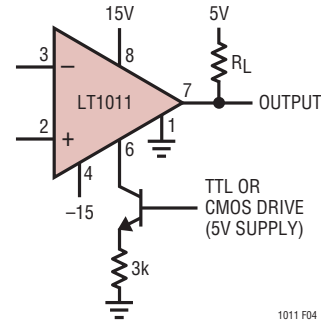

Figure 4. Typical Strobe Circuit

level inputs. A 1pF capacitor between the output and Pin 5 will greatly reduce oscillation problems without reducing strobe speed.

DC hysteresis can also be added by placing a resistor from the output to Pin 5. See step 5 under “Preventing Oscillation Problems.”

The pin (6) used for strobing is also one of the offset adjust pins. Current flow into or out of Pin 6 must be kept very low (<0.2 μ A) when not strobing to prevent input offset voltage shifts.

Output Transistor

The LT1011 output transistor is truly floating in the sense that no current flows into or out of either the collector or emitter when the transistor is in the “off” state. The equivalent circuit is shown in Figure 5.

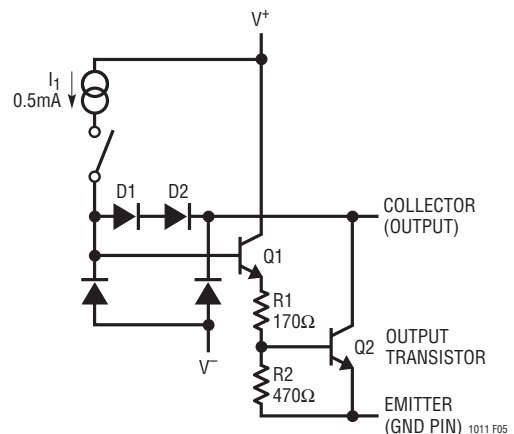

Figure 5. Output Transistor Circuitry

APPLICATIONS INFORMATION

In the “off” state, I_1 is switched off and both Q1 and Q2 turn off. The collector of Q2 can be now held at any voltage above V^- without conducting current, including voltages above the positive supply level. Maximum voltage above V^- is 50V for the LT1011M and 40V for the LT1011C/L. The emitter can be held at any voltage between V^+ and V^- as long as it is negative with respect to the collector.

In the “on” state, I_1 is connected, turning on Q1 and Q2. Diodes D1 and D2 prevent deep saturation of Q2 to improve speed and also limit the drive current of Q1. The R1/R2 divider sets the saturation voltage of Q2 and provides turn-off drive. Either the collector or emitter pin can be held at a voltage between V^+ and V^- . This allows the remaining pin to drive the load. In typical applications, the emitter is connected to V^- or ground and the collector drives a load tied to V^+ or a separate positive supply.

When the emitter is used as the output, the collector is typically tied to V^+ and the load is connected to ground or V^- . Note that the emitter output is phase reversed with respect to the collector output so that the “+” and “-” input designations must be reversed. When the collector

is tied to V^+ , the voltage at the emitter in the “on” state is about 2V below V^+ (see curves).

Input Signal Range

The common mode input voltage range of the LT1011 is about 300mV above the negative supply and 1.5V below the positive supply, independent of the actual supply voltages (see curve in the Typical Performance Characteristics). This is the voltage range over which the output will respond correctly when the common mode voltage is applied to one input and a higher or lower signal is applied to the remaining input. *If one input is inside the common mode range and one is outside, the output will be correct. If the inputs are outside the common mode range in opposite directions, the output will still be correct. If both inputs are outside the common mode range in the same direction, the output will not respond to the differential input; for temperatures of 25°C and above, the output will remain unconditionally high (collector output), for temperatures below 25°C, the output becomes undefined.*

TYPICAL APPLICATIONS

Offset Balancing

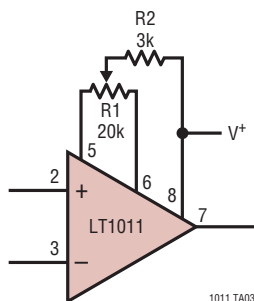

1011 TA03

Driving Load Referenced to Positive Supply

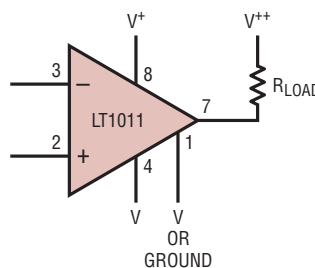

V^{++} CAN BE GREATER OR LESS THAN V^+
1011 TA05

Driving Load Referenced to Negative Supply

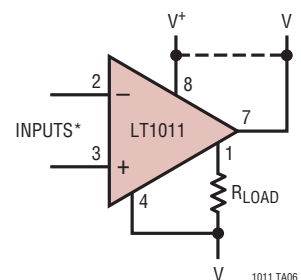

1011 TA06

*INPUT POLARITY IS REVERSED WHEN USING PIN 1 AS OUTPUT

TYPICAL APPLICATIONS

Strobing

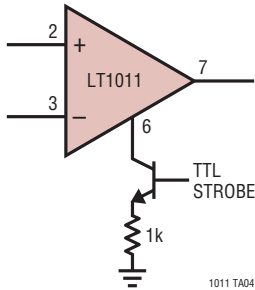

NOTE: DO NOT GROUND STROBE PIN

1011 TA04

Driving Ground Referred Load

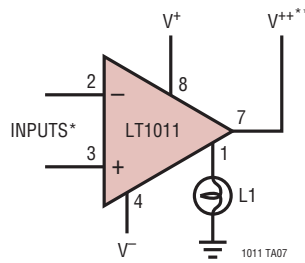

*INPUT POLARITY IS REVERSED WHEN USING PIN 1 AS OUTPUT
 **V⁺⁺ MAY BE ANY VOLTAGE ABOVE V⁻. PIN 1 SWINGS TO WITHIN ≈2V OF V⁺⁺

1011 TA07

Window Detector

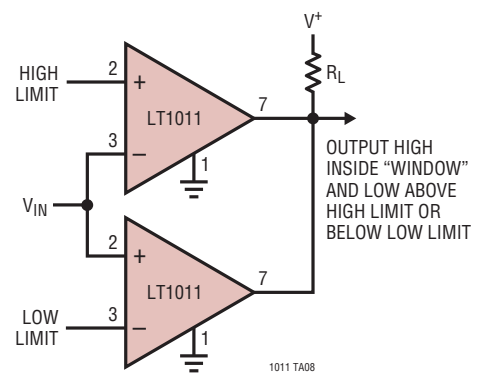

OUTPUT HIGH INSIDE "WINDOW" AND LOW ABOVE HIGH LIMIT OR BELOW LOW LIMIT

1011 TA08

Using Clamp Diodes to Improve Frequency Response*

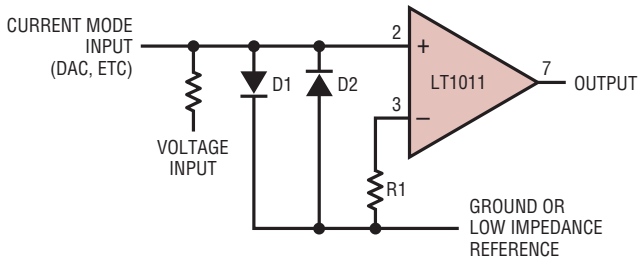

*SEE CURVE, "RESPONSE TIME vs INPUT STEP SIZE"

1011 TA09

Crystal Oscillator

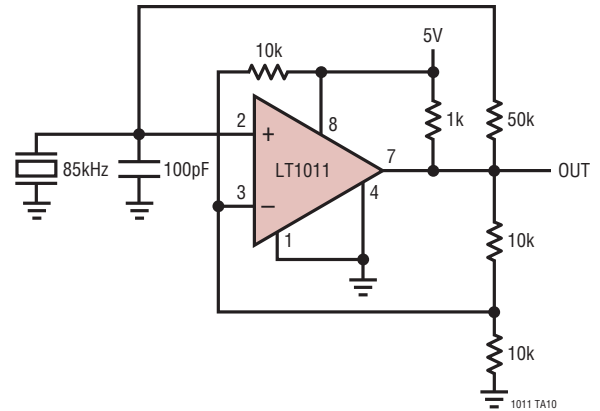

1011 TA10

Noise Immune 60Hz Line Sync**

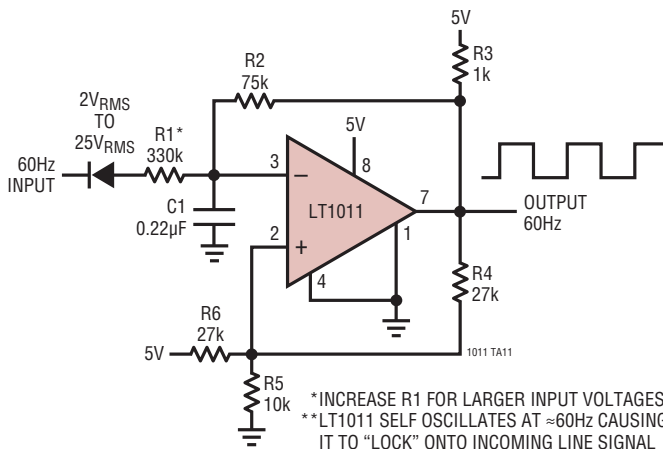

*INCREASE R1 FOR LARGER INPUT VOLTAGES
 **LT1011 SELF OSCILLATES AT ≈60Hz CAUSING IT TO "LOCK" ONTO INCOMING LINE SIGNAL

1011 TA11

High Efficiency** Motor Speed Controller

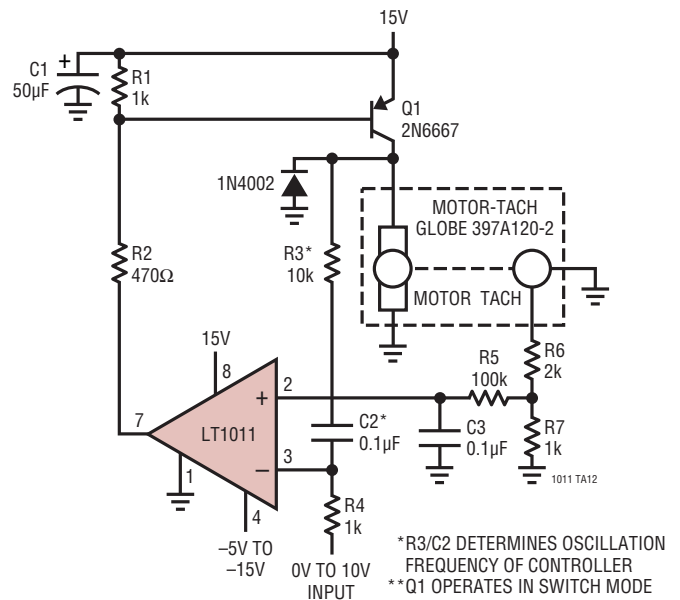

*R3/C2 DETERMINES OSCILLATION FREQUENCY OF CONTROLLER
 **Q1 OPERATES IN SWITCH MODE

1011 TA12

1011afe

TYPICAL APPLICATIONS

Combining Offset Adjust and Strobe

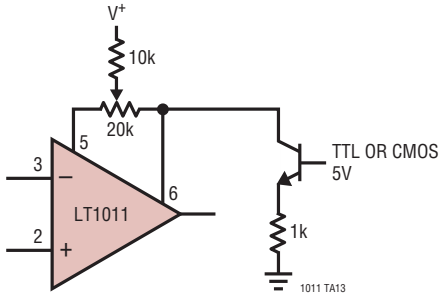

Combining Offset Adjustment and Hysteresis

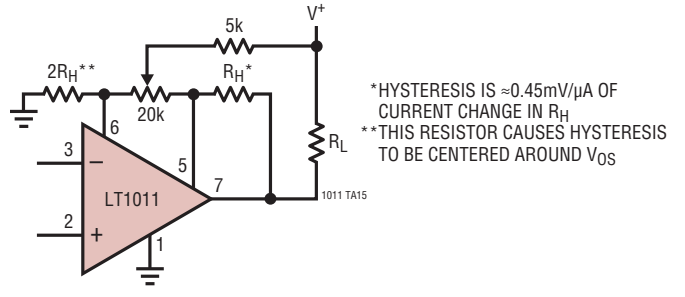

*HYSTERESIS IS $\approx 0.45\text{mV}/\mu\text{A}$ OF CURRENT CHANGE IN R_H
 **THIS RESISTOR CAUSES HYSTERESIS TO BE CENTERED AROUND V_{OS}

Direct Strobe Drive When CMOS* Logic Uses Same V^+ Supply as LT1011

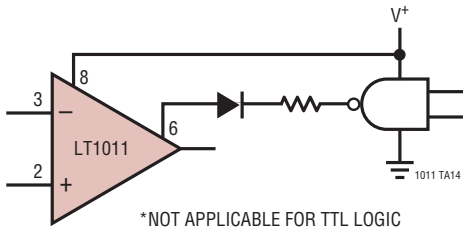

*NOT APPLICABLE FOR TTL LOGIC

Low Drift R/C Oscillator†

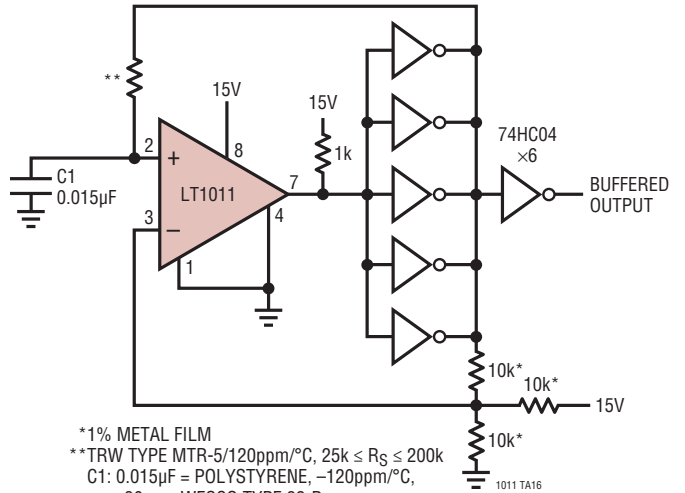

*1% METAL FILM
 **TRW TYPE MTR-5/120ppm/°C, $25\text{k} \leq R_S \leq 200\text{k}$
 C1: 0.015µF = POLYSTYRENE, -120ppm/°C, $\pm 30\text{ppm}$ WESCO TYPE 32-P
 NOTE: COMPARATOR CONTRIBUTES $\leq 10\text{ppm}/^\circ\text{C}$ DRIFT FOR FREQUENCIES BELOW 10kHz
 †LOW DRIFT AND ACCURATE FREQUENCY ARE OBTAINED BECAUSE THIS CONFIGURATION REJECTS EFFECTS DUE TO INPUT OFFSET VOLTAGE AND BIAS CURRENT OF THE COMPARATOR

Positive Peak Detector

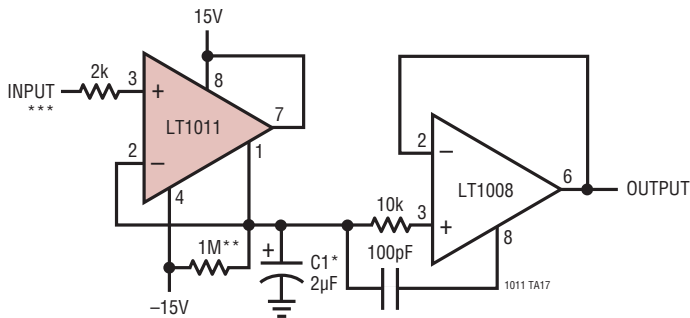

*MYLAR
 **SELECT FOR REQUIRED RESET TIME CONSTANT
 ***INPUT POLARITY IS REVERSED WHEN USING PIN 1 AS OUTPUT

Negative Peak Detector

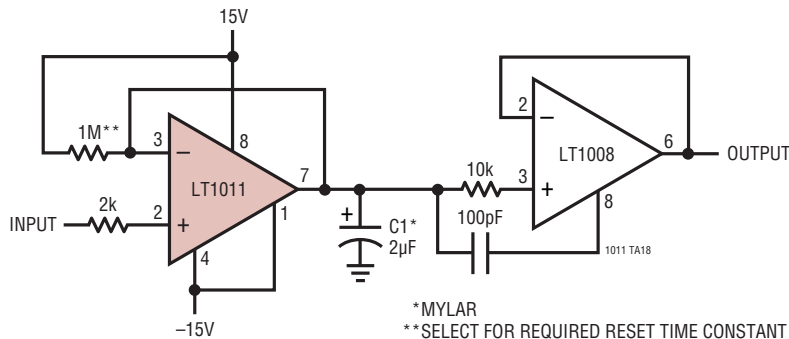

*MYLAR
 **SELECT FOR REQUIRED RESET TIME CONSTANT

TYPICAL APPLICATIONS

Fast Settling Filter

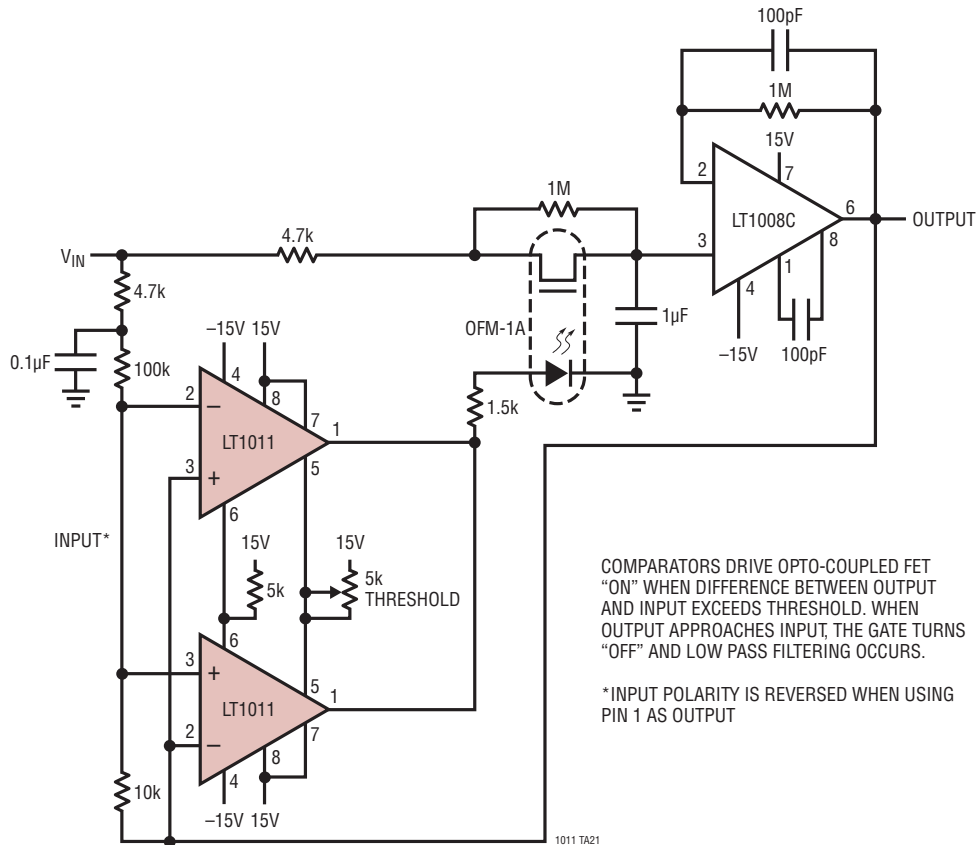

100kHz Precision Rectifier

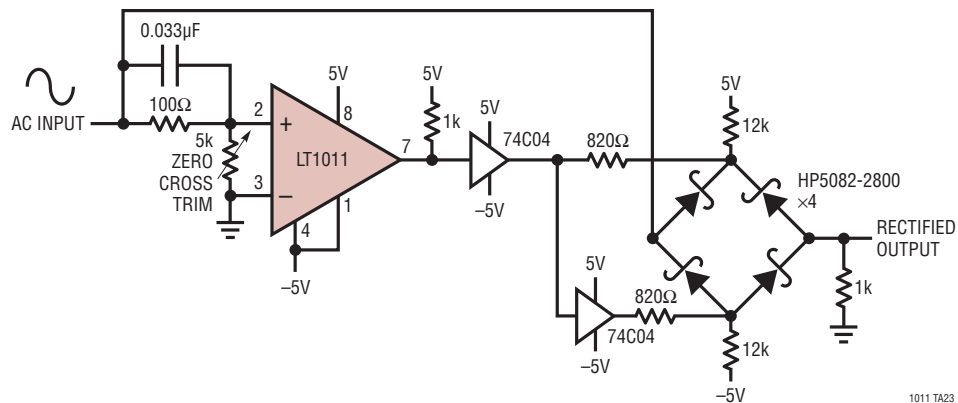

SCHEMATIC DIAGRAM

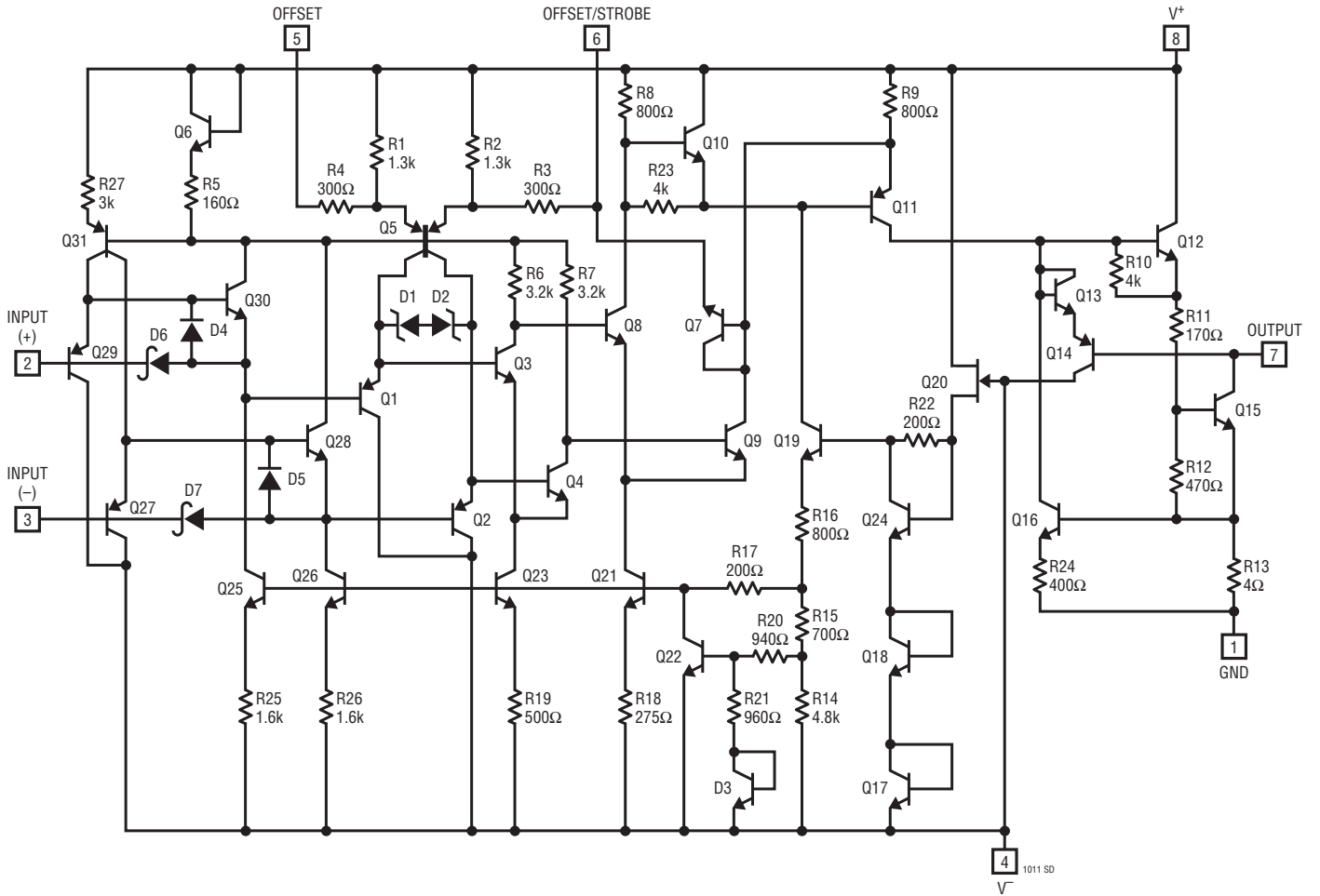

PACKAGE DESCRIPTION

Please refer to <http://www.linear.com/designtools/packaging/> for the most recent package drawings.

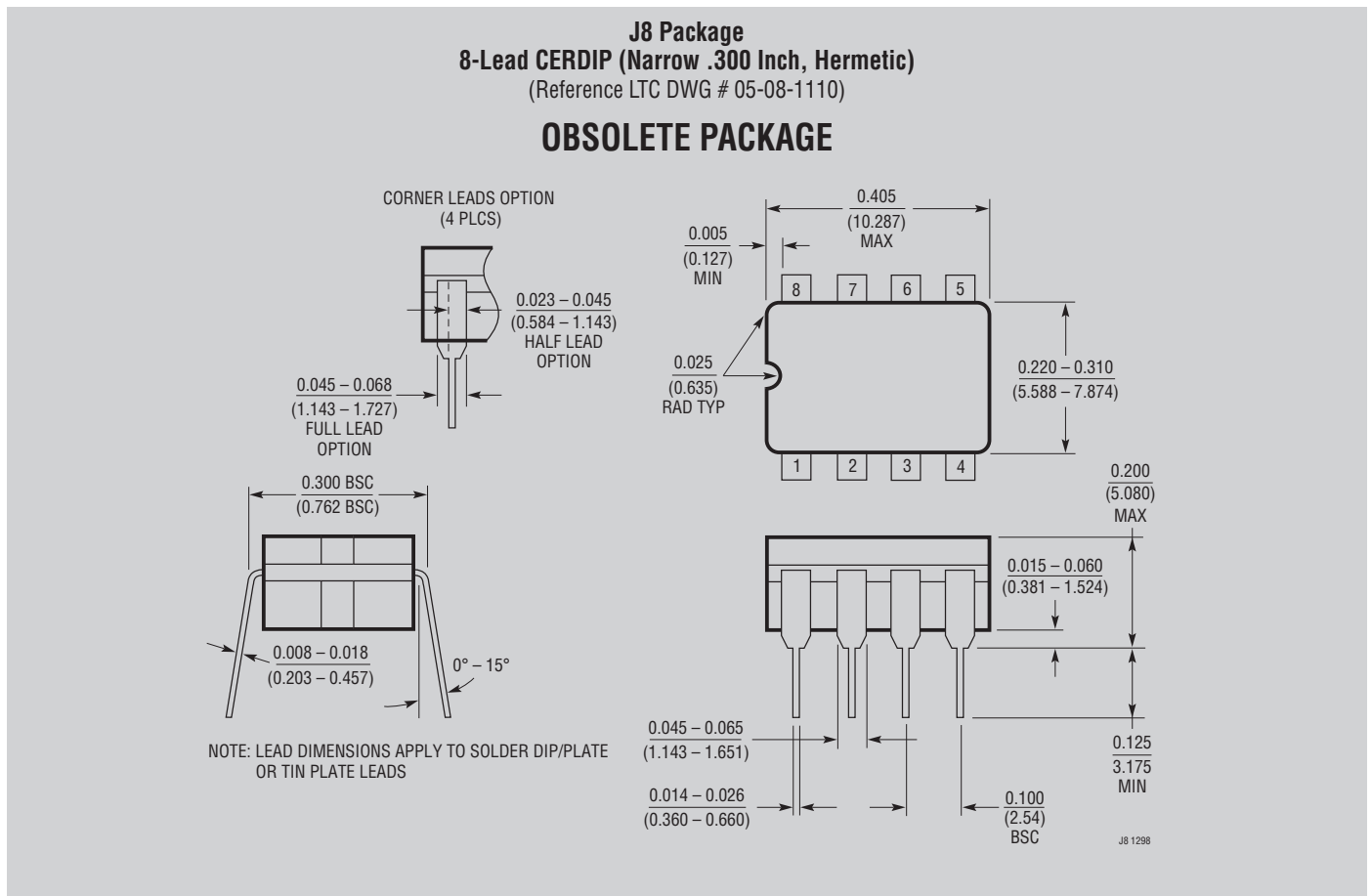
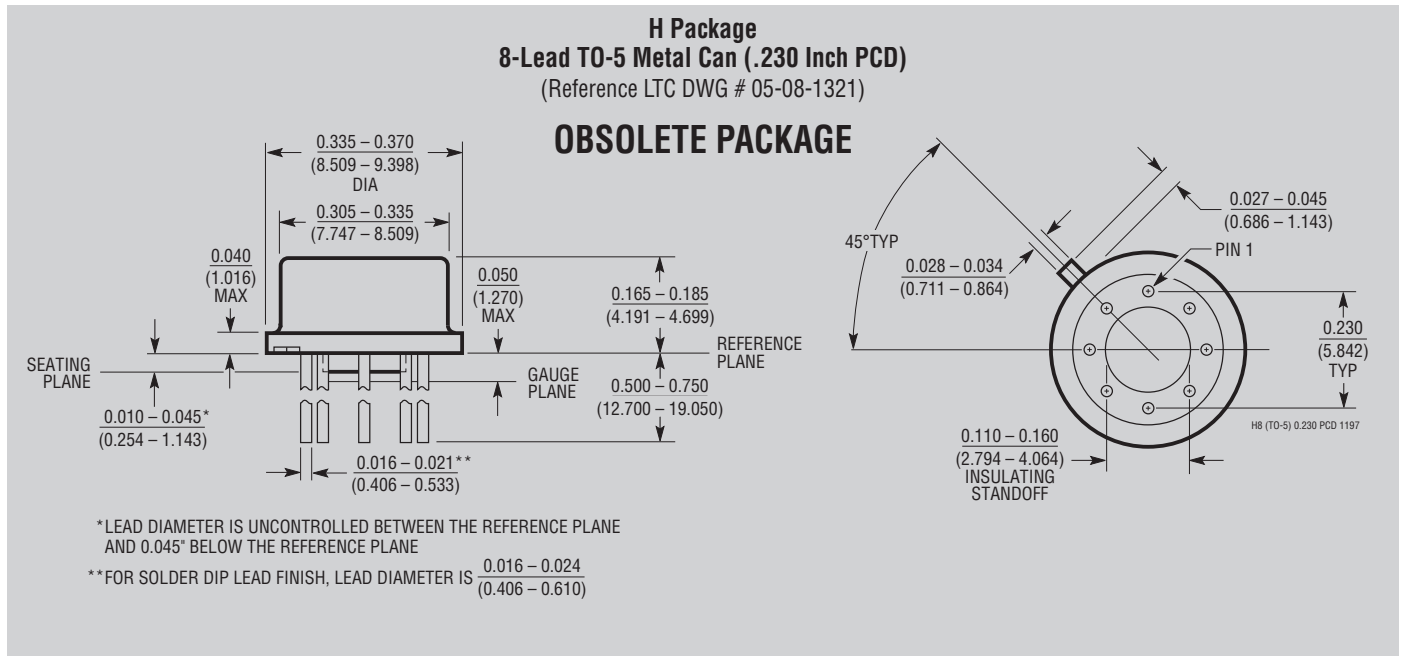

PACKAGE DESCRIPTION

Please refer to <http://www.linear.com/designtools/packaging/> for the most recent package drawings.

N8 Package 8-Lead PDIP (Narrow .300 Inch) (Reference LTC DWG # 05-08-1510)

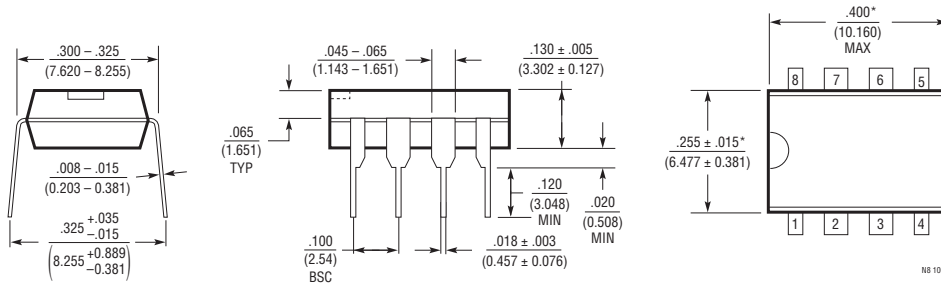

NOTE:
1. DIMENSIONS ARE IN INCHES
MILLIMETERS
*THESE DIMENSIONS DO NOT INCLUDE MOLD FLASH OR PROTRUSIONS.
MOLD FLASH OR PROTRUSIONS SHALL NOT EXCEED .010 INCH (0.254mm)

S8 Package 8-Lead Plastic Small Outline (Narrow .150 Inch) (Reference LTC DWG # 05-08-1610)

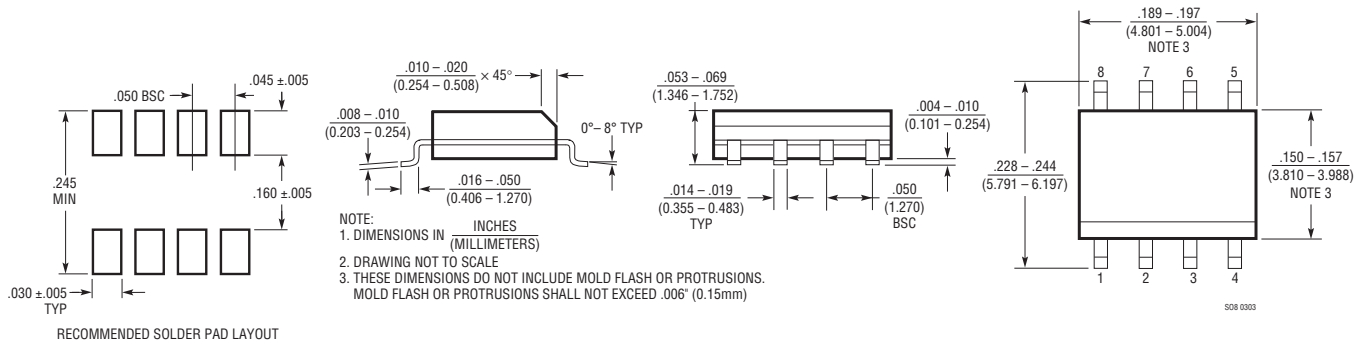

NOTE:
1. DIMENSIONS IN INCHES
(MILLIMETERS)
2. DRAWING NOT TO SCALE
3. THESE DIMENSIONS DO NOT INCLUDE MOLD FLASH OR PROTRUSIONS.
MOLD FLASH OR PROTRUSIONS SHALL NOT EXCEED .006" (0.15mm)

RECOMMENDED SOLDER PAD LAYOUT

REVISION HISTORY (Revision history begins at Rev D)

REV	DATE	DESCRIPTION	PAGE NUMBER
D	10/12	Update to Product Description	1
		Addition of Order Information	2, 3
		Addition of Pin Function Information	7
		Correction to Positive Peak Detector Circuit	13
E	4/13	Correction to Pin Function descriptions	2, 7
		Correction to Order Information and Obsolete Packages	3
		Correction to Graphs:	5, 6
		Response Time—Collector Output – high to low	
		Response Time Using GND Pin as Output – low to high	
		Response Time Using GND Pin as Output – high to low	
		Output Saturation—Ground Output	
Correction to input pin polarity	10, 13, 15		

TYPICAL APPLICATION

10Hz to 100kHz Voltage to Frequency Converter

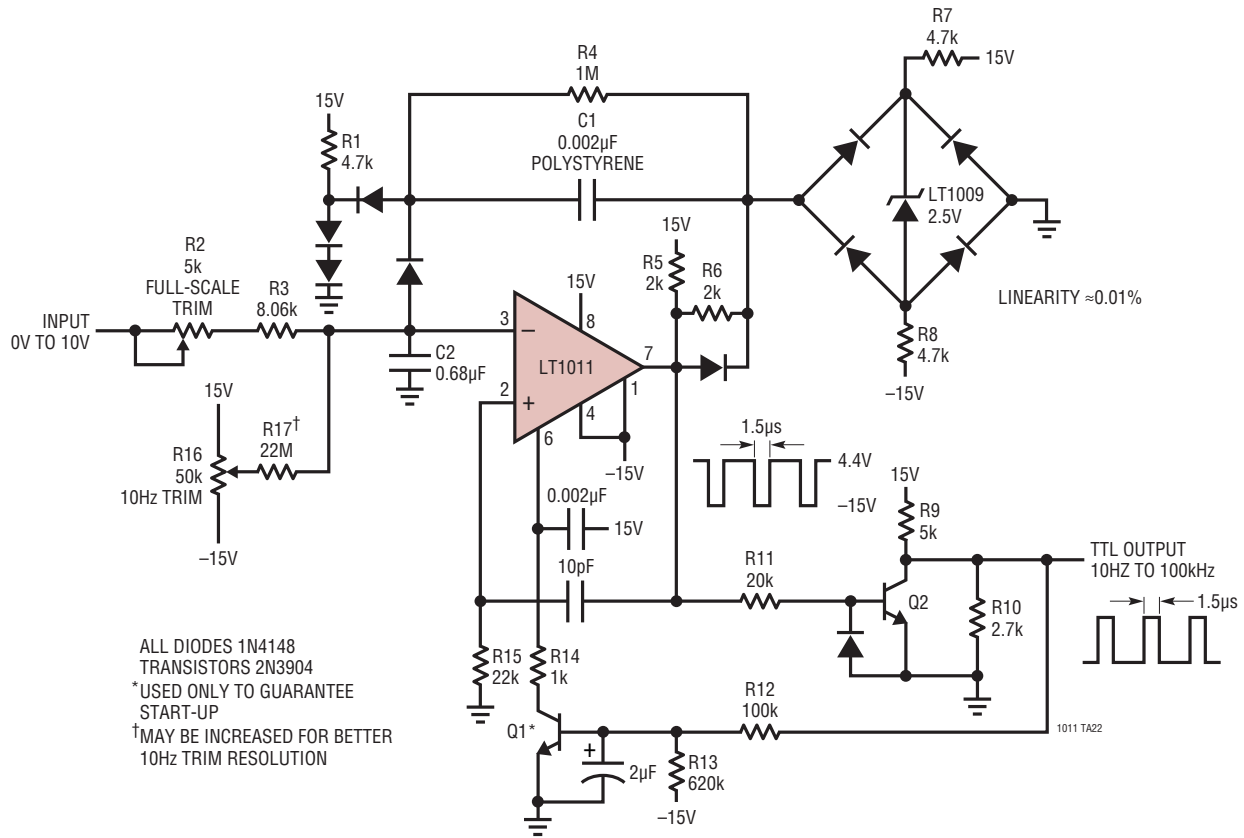

RELATED PARTS

PART NUMBER	DESCRIPTION	COMMENTS
LT1016	UltraFast™ Precision Comparator	Industry Standard 10ns Comparator
LT1116	12ns Single Supply Ground-Sensing Comparator	Single Supply Version of the LT1016
LT1394	UltraFast Single Supply Comparator	7ns, 6mA Single Supply Comparator
LT1671	60ns, Low Power Comparator	450µA Single Supply Comparator

UltraFast is a trademark of Linear Technology Corporation.

Looking for pricing, stock, or lifecycle information?

Click below to explore more details on WIN SOURCE:

 [View LT1011AIS8#TRPBF on WIN SOURCE](#)

 [Linear Technology](#) Information

Optimize Your Supply Chain with WIN SOURCE Solutions

-  Global Sourcing Solution
-  Obsolete Management
-  Cost Control Management
-  Shortage Management
-  Alternative Solution
-  Excess Inventory Management