



# THE DATASHEET OF TLC552CDR



- **Very Low Power Consumption . . . 2 mW**  
Typ at  $V_{DD} = 5\text{ V}$
- **Capable of Operation in Astable Mode**
- **CMOS Output Capable of Swinging Rail to Rail**
- **High Output-Current Capability**  
Sink 100 mA Typ  
Source 10 mA Typ
- **Output Fully Compatible With CMOS, TTL, and MOS**
- **Low Supply Current Reduces Spikes During Output Transitions**
- **High-Impedance Inputs . . .  $10^{12}\ \Omega$  Typ**
- **Single-Supply Operation From 1 V to 18 V**
- **Functionally Interchangeable With the NE556; Has Same Pinout**

## description

The TLC552 is a dual monolithic timing circuit fabricated using TI LinCMOS™ process, which provides full compatibility with CMOS, TTL, and MOS logic and operation at frequencies up to 2 MHz. Accurate time delays and oscillations are possible with smaller, less-expensive timing capacitors than the NE555 because of the high input impedance. Power consumption is low across the full range of power supply voltages.

Like the NE556, the TLC552 has a trigger level approximately one-third of the supply voltage and a threshold level approximately two-thirds of the supply voltage. These levels can be altered by use of the control voltage terminal. When the trigger input falls below the trigger level, the flip-flop is set and the output goes high. If the trigger input is above the trigger level and the threshold input is above the threshold level, the flip-flop is reset and the output is low. The reset input can override all other inputs and can be used to initiate a new timing cycle. If the reset input is low, the flip-flop is reset and the output is low. Whenever the output is low, a low-impedance path is provided between the discharge terminal and ground.

While the CMOS output is capable of sinking over 100 mA and sourcing over 10 mA, the TLC552 exhibits greatly reduced supply-current spikes during output transitions. This minimizes the need for the large decoupling capacitors required by the NE556.

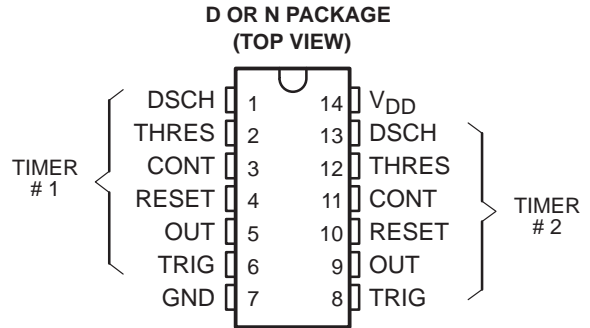

## functional block diagram (each timer)

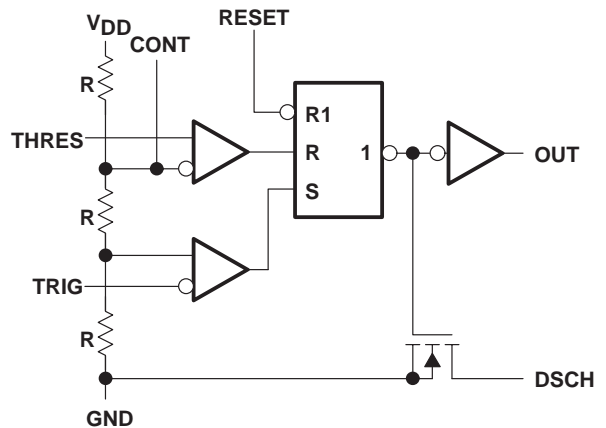

RESET can override TRIG and THRES.  
TRIG can override THRES.

## AVAILABLE OPTIONS

SYMBOLIZATION		OPERATING TEMPERATURE RANGE	$V_T$ max at 25°C
DEVICE	PACKAGE SUFFIX		
TLC552C	D,N	0°C to 70°C	3.8 mV

The D packages are available taped and reeled. Add the suffix R to the device type when ordering (i.e., TLC552CDR).

LinCMOS is a trademark of Texas Instruments Incorporated.

PRODUCTION DATA information is current as of publication date. Products conform to specifications per the terms of Texas Instruments standard warranty. Production processing does not necessarily include testing of all parameters.

 **TEXAS  
INSTRUMENTS**

POST OFFICE BOX 655303 • DALLAS, TEXAS 75265

Copyright © 1988, Texas Instruments Incorporated

# TLC552C DUAL LINCOS™ TIMER

SLFS046 – FEBRUARY 1984 – REVISED MAY 1988

## description (continued)

These devices have internal electrostatic discharge (ESD) protection circuits that will prevent catastrophic failures at voltages up to 2000 V as tested under MIL-STD-883C, Method 3105.2. However, care should be exercised in handling these devices as exposure to ESD may result in a degradation of the device parametric performance.

All unused inputs should be tied to an appropriate logic level to prevent false triggering.

The TLC552C is characterized for operation from 0°C to 70°C.

FUNCTION TABLE

RESET VOLTAGE†	TRIGGER VOLTAGE†	THRESHOLD VOLTAGE†	OUTPUT	DISCHARGE SWITCH
< MIN	Irrelevant	Irrelevant	Low	On
> MAX	< MIN	Irrelevant	High	Off
> MAX	> MAX	> MAX	Low	On
> MAX	> MAX	< MIN	As previously established	

† For conditions shown as MIN or MAX, use the appropriate value specified under electrical characteristics.

## absolute maximum ratings over operating free-air temperature range (unless otherwise noted)

Supply voltage, $V_{DD}$ (see Note 1)	18 V
Input voltage range (any input)	-0.3 V to $V_{DD}$
Sink current, DSCH or OUT	150 mA
Source current, OUT	15 mA
Continuous total dissipation	See Dissipation Rating Table
Operating free-air temperature range	0°C to 75°C
Storage temperature range	-65°C to 150°C
Lead temperature 1,6 mm (1/16 inch) from case for 10 seconds	260°C

NOTES: 1. All voltage values are with respect to network ground terminal.

DISSIPATION RATING TABLE

PACKAGE	POWER RATING	DERATING FACTOR	ABOVE $T_A$
D	950 mW	7.6 mW/°C	25°C
N	1150 mW	9.2 mW/°C	25°C

## recommended operating conditions

	MIN	MAX	UNIT
Supply voltage, $V_{DD}$	1	18	V
Operating free-air temperature range, $T_A$	0	70	°C



electrical characteristics at specified free-air temperature,  $V_{DD} = 1\text{ V}$

PARAMETER	TEST CONDITIONS	$T_A^\dagger$	MIN	TYP	MAX	UNIT
Threshold voltage level		25°C	0.475	0.67	0.85	V
		Full range	0.45		0.875	
Threshold current		25°C		10		pA
		MAX		75		
Trigger voltage level		25°C	0.15	0.33	0.425	V
		Full range	0.1		1.45	
Trigger current		25°C		10		pA
		MAX		75		
Reset voltage level		25°C	0.4	0.7	1	V
		Full range	0.3		1	
Reset current		25°C		10		pA
		MAX		75		
Control voltage (open-circuit) as a percentage of supply voltage		MAX		66.7%		
Discharge switch on-state voltage	$I_{OL} = 100\ \mu\text{A}$	25°C		0.02	0.15	V
		Full range			0.2	
Discharge switch off-state current		25°C		0.1		nA
		MAX		0.5		
Low-level output voltage	$I_{OL} = 100\ \mu\text{A}$	25°C		0.03	0.2	V
		Full range			0.25	
High-level output voltage	$I_{OH} = -10\ \mu\text{A}$	25°C	0.6	0.98		V
		Full range	0.6			
Supply current		25°C		30	200	$\mu\text{A}$
		Full range			300	

† Full range (MIN to MAX) is 0°C to 70°C.

# TLC552C DUAL LINCMOS™ TIMER

SLFS046 – FEBRUARY 1984 – REVISED MAY 1988

## electrical characteristics at specified free-air temperature, $V_{DD} = 2\text{ V}$

PARAMETER	TEST CONDITIONS	$T_A$ †	MIN	TYP	MAX	UNIT
Threshold voltage level		25°C	0.95	1.33	1.65	V
		Full range	0.85		1.75	
Threshold current		25°C	10			pA
		MAX	75			
Trigger voltage level		25°C	0.4	0.67	0.95	V
		Full range	0.3		1.05	
Trigger current		25°C	10			pA
		MAX	75			
Reset voltage level		25°C	0.4	1.1	1.5	V
		Full range	0.3		1.8	
Reset current		25°C	10			pA
		MAX	75			
Control voltage (open-circuit) as a percentage of supply voltage		MAX	66.7%			
Discharge switch on-state voltage	$I_{OL} = 1\text{ mA}$	25°C	0.03		0.2	V
		Full range	0.25			
Discharge switch off-state current		25°C	0.1			nA
		MAX	0.5			
Low-level output voltage	$I_{OL} = 1\text{ mA}$	25°C	0.07		0.3	V
		Full range	0.35			
High-level output voltage	$I_{OH} = -300\text{ }\mu\text{A}$	25°C	1.5	1.9		V
		Full range	1.5			
Supply current		25°C	130		500	$\mu\text{A}$
		Full range	800			

† Full range (MIN to MAX) is 0°C to 70°C.

electrical characteristics at specified free-air temperature,  $V_{DD} = 5\text{ V}$

PARAMETER	TEST CONDITIONS	$T_A^\dagger$	MIN	TYP	MAX	UNIT
Threshold voltage level		25°C	2.8	3.3	3.8	V
		Full range	2.7		3.9	
Threshold current		25°C		10		pA
		MAX		75		
Trigger voltage level		25°C	1.36	1.66	1.96	V
		Full range	1.26		2.06	
Trigger current		25°C		10		pA
		MAX		75		
Reset voltage level		25°C	0.4	1.1	1.5	V
		Full range	0.3		1.8	
Reset current		25°C		10		pA
		MAX		75		
Control voltage (open-circuit) as a percentage of supply voltage		MAX		66.7%		
Discharge switch on-state voltage	$I_{OL} = 10\text{ mA}$	25°C		0.14	0.5	V
		Full range			0.6	
Discharge switch off-state current		25°C		0.1		nA
		MAX		0.5		
Low-level output voltage	$I_{OL} = 8\text{ mA}$	25°C		0.21	0.4	V
		Full range			0.5	
	$I_{OL} = 5\text{ mA}$	25°C		0.13	0.3	
		Full range			0.4	
	$I_{OL} = 3.2\text{ mA}$	25°C		0.08	0.3	
		Full range			0.35	
High-level output voltage	$I_{OH} = -1\text{ mA}$	25°C	4.1	4.8		V
		Full range	4.1			
Supply current		25°C		340	700	$\mu\text{A}$
		Full range			1000	

† Full range (MIN to MAX) is 0°C to 70°C.

# TLC552C DUAL LINCMOS™ TIMER

SLFS046 – FEBRUARY 1984 – REVISED MAY 1988

## electrical characteristics at specified free-air temperature, $V_{DD} = 15\text{ V}$

PARAMETER	TEST CONDITIONS	$T_A$ †	MIN	TYP	MAX	UNIT
Threshold voltage level		25°C	9.45	10	10.55	V
		Full range	9.35		10.65	
Threshold current		25°C		10		pA
		MAX		75		
Trigger voltage level		25°C	4.65	5	5.35	V
		Full range	4.55		5.45	
Trigger current		25°C		10		pA
		MAX		75		
Reset voltage level		25°C	0.4	1.1	1.5	V
		Full range	0.3		1.8	
Reset current		25°C		10		pA
		MAX		75		
Control voltage (open-circuit) as a percentage of supply voltage		MAX		66.7%		
Discharge switch on-state voltage	$I_{OL} = 100\text{ mA}$	25°C		0.77	1.7	V
		Full range			1.8	
Discharge switch off-state current		25°C		0.1		nA
		MAX		0.5		
Low-level output voltage	$I_{OL} = 100\text{ mA}$	25°C		1.28	3.2	V
		Full range			3.6	
	$I_{OL} = 50\text{ mA}$	25°C		0.63	1	
		Full range			1.3	
	$I_{OL} = 10\text{ mA}$	25°C		0.12	0.3	
		Full range			0.4	
High-level output voltage	$I_{OH} = -10\text{ mA}$	25°C	12.5	14.2	V	
		Full range	12.5			
	$I_{OH} = -5\text{ mA}$	25°C	13.5	14.6		
		Full range	13.5			
	$I_{OH} = -1\text{ mA}$	25°C	14.2	14.9		
		Full range	14.2			
Supply current		25°C		0.72	1.2	mA
		Full range			1.6	

† Full range (MIN to MAX) is 0°C to 70°C.

**electrical characteristics at specified free-air temperature,  $V_{DD} = 18\text{ V}$**

PARAMETER	TEST CONDITIONS	$T_A$ †	MIN	TYP	MAX	UNIT
Threshold voltage level		25°C	11.4	12	12.6	V
		Full range	10.9		12.7	
Threshold current		25°C		10		pA
		MAX		75		
Trigger voltage level		25°C	5.6	6	6.4	V
		Full range	5.5		6.5	
Trigger current		25°C		10		pA
		MAX		75		
Reset voltage level		25°C	0.4	1.1	1.5	V
		Full range	0.3		1.8	
Reset current		25°C		10		pA
		MAX		75		
Control voltage (open-circuit) as a percentage of supply voltage		MAX	66.7%			
Discharge switch on-state voltage	$I_{OL} = 100\text{ mA}$	25°C		0.72	1.5	V
		Full range			1.6	
Discharge switch off-state current		25°C		0.1		nA
		MAX		0.5		
Low-level output voltage	$I_{OL} = 3.2\text{ mA}$	25°C		0.04	0.3	V
		Full range			0.35	
High-level output voltage	$I_{OH} = -1\text{ mA}$	25°C	17.3	17.9		V
		Full range	17.3			
Supply current		25°C		0.84	1.2	mA
		Full range			1.6	

† Full range (MIN to MAX) is 0°C to 70°C.

**operating characteristics,  $V_{DD} = 5\text{ V}$ ,  $T_A = 25^\circ\text{C}$  (unless otherwise noted)**

PARAMETER	TEST CONDITIONS	MIN	TYP	MAX	UNIT
Initial error of timing interval‡	$V_{DD} = 5\text{ V to }15\text{ V}$ , $C_T = 0.1\ \mu\text{F}$ ,		1%	3%	
Supply voltage sensitivity of timing interval		$R_A = R_B = 1\text{ k}\Omega\text{ to }100\text{ k}\Omega$ , See Note 2		0.1	0.5
Output pulse rise time	$R_L = 10\text{ M}\Omega$ , $C_L = 10\text{ pF}$		20	75	ns
Output pulse fall time			15	60	
Maximum frequency in astable mode	$R_A = 470\ \Omega$ , $C_T = 200\text{ pF}$ ,		1.2	2.8	MHz
	$R_B = 200\ \Omega$ , See Note 2				

‡ Timing interval error is defined as the difference between the measured value and the nominal value of a random sample.

NOTE 2:  $R_A$ ,  $R_B$ , and  $C_T$  are as defined in Figure 1.

APPLICATION INFORMATION

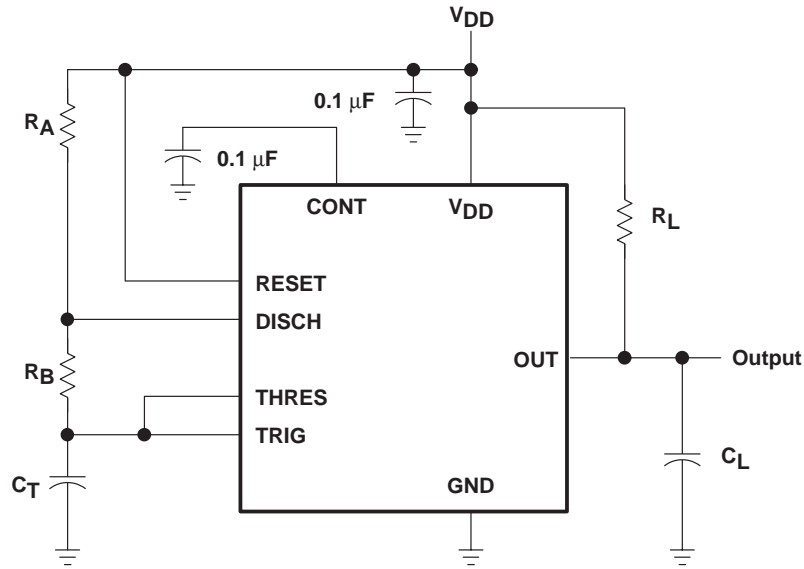

Figure 1. Circuit for Astable Operation

**PACKAGING INFORMATION**

Orderable Device	Status (1)	Package Type	Package Drawing	Pins	Package Qty	Eco Plan (2)	Lead/Ball Finish (6)	MSL Peak Temp (3)	Op Temp (°C)	Device Marking (4/5)	Samples
TLC552CD	ACTIVE	SOIC	D	14	50	Green (RoHS & no Sb/Br)	CU NIPDAU	Level-1-260C-UNLIM	0 to 70	TLC552C	<a href="#">Samples</a>
TLC552CDR	ACTIVE	SOIC	D	14	2500	Green (RoHS & no Sb/Br)	CU NIPDAU	Level-1-260C-UNLIM	0 to 70	TLC552C	<a href="#">Samples</a>
TLC552CN	ACTIVE	PDIP	N	14	25	Green (RoHS & no Sb/Br)	CU NIPDAU	N / A for Pkg Type	0 to 70	TLC552CN	<a href="#">Samples</a>

(1) The marketing status values are defined as follows:

**ACTIVE:** Product device recommended for new designs.

**LIFEBUY:** TI has announced that the device will be discontinued, and a lifetime-buy period is in effect.

**NRND:** Not recommended for new designs. Device is in production to support existing customers, but TI does not recommend using this part in a new design.

**PREVIEW:** Device has been announced but is not in production. Samples may or may not be available.

**OBsolete:** TI has discontinued the production of the device.

(2) **RoHS:** TI defines "RoHS" to mean semiconductor products that are compliant with the current EU RoHS requirements for all 10 RoHS substances, including the requirement that RoHS substance do not exceed 0.1% by weight in homogeneous materials. Where designed to be soldered at high temperatures, "RoHS" products are suitable for use in specified lead-free processes. TI may reference these types of products as "Pb-Free".

**RoHS Exempt:** TI defines "RoHS Exempt" to mean products that contain lead but are compliant with EU RoHS pursuant to a specific EU RoHS exemption.

**Green:** TI defines "Green" to mean the content of Chlorine (Cl) and Bromine (Br) based flame retardants meet JS709B low halogen requirements of <=1000ppm threshold. Antimony trioxide based flame retardants must also meet the <=1000ppm threshold requirement.

(3) MSL, Peak Temp. - The Moisture Sensitivity Level rating according to the JEDEC industry standard classifications, and peak solder temperature.

(4) There may be additional marking, which relates to the logo, the lot trace code information, or the environmental category on the device.

(5) Multiple Device Markings will be inside parentheses. Only one Device Marking contained in parentheses and separated by a "-" will appear on a device. If a line is indented then it is a continuation of the previous line and the two combined represent the entire Device Marking for that device.

(6) Lead/Ball Finish - Orderable Devices may have multiple material finish options. Finish options are separated by a vertical ruled line. Lead/Ball Finish values may wrap to two lines if the finish value exceeds the maximum column width.

**Important Information and Disclaimer:**The information provided on this page represents TI's knowledge and belief as of the date that it is provided. TI bases its knowledge and belief on information provided by third parties, and makes no representation or warranty as to the accuracy of such information. Efforts are underway to better integrate information from third parties. TI has taken and continues to take reasonable steps to provide representative and accurate information but may not have conducted destructive testing or chemical analysis on incoming materials and chemicals. TI and TI suppliers consider certain information to be proprietary, and thus CAS numbers and other limited information may not be available for release.

In no event shall TI's liability arising out of such information exceed the total purchase price of the TI part(s) at issue in this document sold by TI to Customer on an annual basis.

## TAPE AND REEL INFORMATION

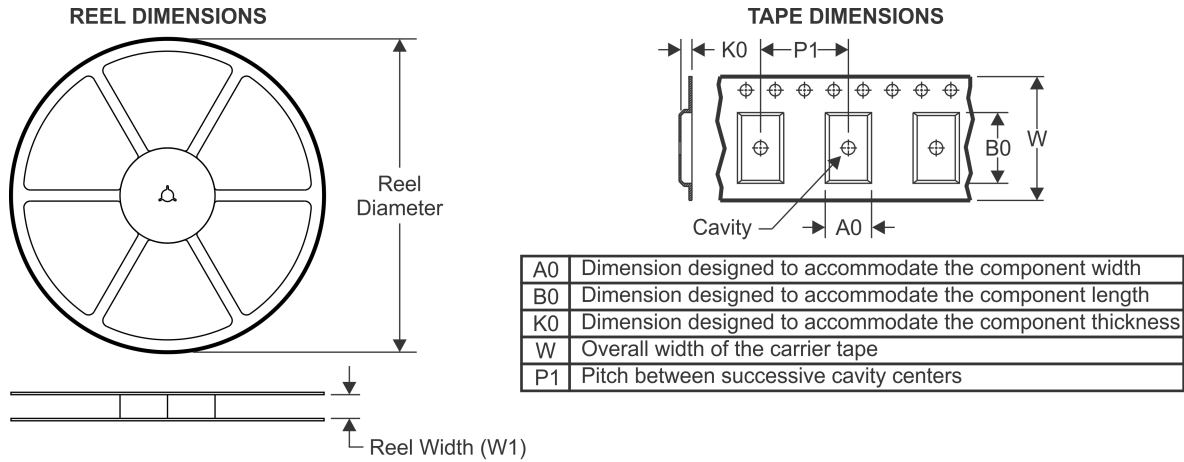

### QUADRANT ASSIGNMENTS FOR PIN 1 ORIENTATION IN TAPE



\*All dimensions are nominal

Device	Package Type	Package Drawing	Pins	SPQ	Reel Diameter (mm)	Reel Width W1 (mm)	A0 (mm)	B0 (mm)	K0 (mm)	P1 (mm)	W (mm)	Pin1 Quadrant
TLC552CDR	SOIC	D	14	2500	330.0	16.4	6.5	9.0	2.1	8.0	16.0	Q1

**TAPE AND REEL BOX DIMENSIONS**



\*All dimensions are nominal

Device	Package Type	Package Drawing	Pins	SPQ	Length (mm)	Width (mm)	Height (mm)
TLC552CDR	SOIC	D	14	2500	350.0	350.0	43.0

## IMPORTANT NOTICE AND DISCLAIMER

TI PROVIDES TECHNICAL AND RELIABILITY DATA (INCLUDING DATASHEETS), DESIGN RESOURCES (INCLUDING REFERENCE DESIGNS), APPLICATION OR OTHER DESIGN ADVICE, WEB TOOLS, SAFETY INFORMATION, AND OTHER RESOURCES "AS IS" AND WITH ALL FAULTS, AND DISCLAIMS ALL WARRANTIES, EXPRESS AND IMPLIED, INCLUDING WITHOUT LIMITATION ANY IMPLIED WARRANTIES OF MERCHANTABILITY, FITNESS FOR A PARTICULAR PURPOSE OR NON-INFRINGEMENT OF THIRD PARTY INTELLECTUAL PROPERTY RIGHTS.

These resources are intended for skilled developers designing with TI products. You are solely responsible for (1) selecting the appropriate TI products for your application, (2) designing, validating and testing your application, and (3) ensuring your application meets applicable standards, and any other safety, security, or other requirements. These resources are subject to change without notice. TI grants you permission to use these resources only for development of an application that uses the TI products described in the resource. Other reproduction and display of these resources is prohibited. No license is granted to any other TI intellectual property right or to any third party intellectual property right. TI disclaims responsibility for, and you will fully indemnify TI and its representatives against, any claims, damages, costs, losses, and liabilities arising out of your use of these resources.

TI's products are provided subject to TI's Terms of Sale ([www.ti.com/legal/termsofsale.html](http://www.ti.com/legal/termsofsale.html)) or other applicable terms available either on [ti.com](http://ti.com) or provided in conjunction with such TI products. TI's provision of these resources does not expand or otherwise alter TI's applicable warranties or warranty disclaimers for TI products.

Mailing Address: Texas Instruments, Post Office Box 655303, Dallas, Texas 75265  
Copyright © 2019, Texas Instruments Incorporated

## Looking for pricing, stock, or lifecycle information?

Click below to explore more details on WIN SOURCE:

 [View TLC552CDR on WIN SOURCE](#)

 [Texas Instruments](#) Information

## Optimize Your Supply Chain with WIN SOURCE Solutions

-  Global Sourcing Solution
-  Obsolete Management
-  Cost Control Management
-  Shortage Management
-  Alternative Solution
-  Excess Inventory Management