



**THE DATASHEET OF
TPA2100P1YZHT**



19-V_{PP} Mono Class-D Audio Amplifier for Piezo/Ceramic Speakers

FEATURES

- 19 V_{PP} Output Load Voltage From a 2.5 V Supply
- Integrated DC-DC Converter Generates 10 V Supply
- No External Schottky Diode Required
- Integrated Audio Input Low-Pass Filter
- Small Boost Converter Inductor
- Supply Voltage Range From 2.5 V to 5.5 V
- Selectable Gain of 12 dB, 16 dB, and 24 dB
- Independent Shutdown Control for the Boost Converter and the Audio Amplifier
- Fast Startup Time: 8 ms
- Low Supply Current: 5.5 mA
- Low Shutdown Current: < 1 μA
- Short-Circuit and Thermal Protection
- Space Saving Package
 - 2,1 mm × 2,1 mm NanoFree™ WCSP (YZH)

APPLICATIONS

- Wireless or Cellular Handsets
- Portable DVD Player
- Personal Digital Assistants (PDAs)
- Electronic Dictionaries
- Digital Still Cameras

DESCRIPTION

The TPA2100P1 (sometimes referred to as TPA2100) is a mono, Class-D audio power amplifier with integrated DC-DC converter designed for piezo and ceramic speakers. The TPA2100P1 (TPA2100) is capable of driving a ceramic / piezo speaker with 19 V_{PP} (6.7 V_{RMS}) from a 2.5 V power supply at less than 1% THD+N.

The DC-DC converter operates at a fixed frequency of 1.2 MHz. The TPA2100P1 (TPA2100) DC-DC converter provides a 10 V supply with a minimum number of external components. The DC-DC converter can be used to drive other components that require a 10 V supply voltage (note: audio signal must be present for proper functionality of boost converter).

The TPA2100P1 (TPA2100) features an integrated audio low pass filter that rejects high frequency noise (CODEC out-of-band and RF noise) thus improving audio fidelity.

The TPA2100P1 (TPA2100) has three gain modes of 12 dB, 16 dB, and 24 dB. The TPA2100P1 (TPA2100) provides thermal and short circuit protection on the boost converter and the Class-D audio amplifier. The TPA2100P1 (TPA2100) is available in a 16-ball 2,1 mm × 2,1 mm WCSP package. The TPA2100P1 (TPA2100) requires only one small external inductor for operation.

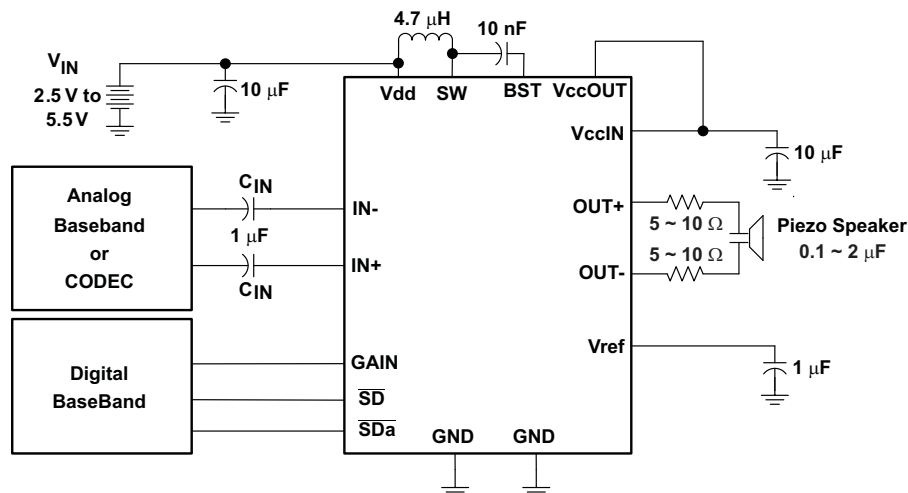

Please be aware that an important notice concerning availability, standard warranty, and use in critical applications of Texas Instruments semiconductor products and disclaimers thereto appears at the end of this data sheet.

NanoFree is a trademark of Texas Instruments.



These devices have limited built-in ESD protection. The leads should be shorted together or the device placed in conductive foam during storage or handling to prevent electrostatic damage to the MOS gates.

DEVICE PINOUT

YZH wcsp) package
(TOP VIEW)

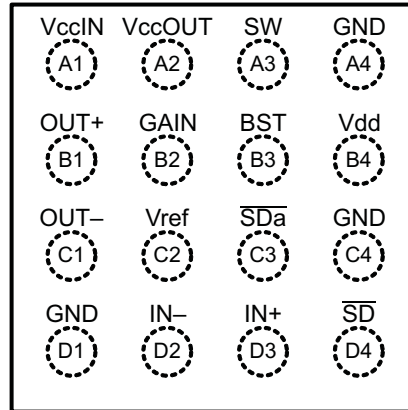

PIN FUNCTIONS

PIN		I/O/P	DESCRIPTION
Name	WCSP		
IN+	D3	I	Positive Differential Audio Input
IN-	D2	I	Negative Differential Audio Input
\overline{SDa}	C3	I	Audio Amplifier Shutdown
GAIN	B2	I	Gain Selection (tri-state input)
\overline{SD}	D4	I	Device Shutdown
Vref	C2	O	Internal Analog Supply (Do not connect to external supply/circuit)
OUT+	B1	O	Positive Differential Audio Output
OUT-	C1	O	Negative Differential Audio Output
BST	B3	O	Reference Voltage for Boost Converter
V _{DD}	B4	P	Power Supply
V _{CC} OUT	A2	P	DC-DC Converter Output Voltage
V _{CC} IN	A1	P	Audio Amplifier Power Supply
SW	A3	P	Boost and Rectifying Switch Input
GND	A4, C4, D1	P	Ground

ABSOLUTE MAXIMUM RATINGS⁽¹⁾

Over operating free-air temperature range (unless otherwise noted)

		VALUE	UNIT
	Supply voltage, V_{DD}	-0.3 to 6.0	V
	Amplifier supply voltage, V_{CCOUT} , V_{CCIN}	-0.3 to 12.0	V
V_I	Input voltage, $IN-$, $IN+$, \overline{SDa} , \overline{SD} , GAIN	-0.3 to $V_{DD} + 0.3$	V
	Output continuous total power dissipation	See Dissipation Rating Table	
T_A	Operating free-air temperature range	-40 to 85	°C
T_J	Operating junction temperature range	-40 to 150	°C
T_{stg}	Storage temperature range	-65 to 150	°C
	ESD Protection — HBM (All Pins)	2	kV

- (1) Stresses beyond those listed under absolute maximum ratings may cause permanent damage to the device. These are stress ratings only, and functional operations of the device at these or any other conditions beyond those indicated under *recommended operating conditions* is not implied. Exposure to absolute-maximum-rated conditions for extended periods may affect device reliability.

DISSIPATION RATINGS⁽¹⁾

PACKAGE	$T_A \leq 25^\circ\text{C}$	DERATING FACTOR	$T_A = 70^\circ\text{C}$	$T_A = 85^\circ\text{C}$
16-ball WCSP (YZH)	1.66 W	13.3 mW/°C	1.06 W	0.86 W

- (1) Dissipation ratings are for a 2-side, 2-plane board JEDEC high K board.

AVAILABLE OPTIONS

T_A	PACKAGED DEVICES ⁽¹⁾	PART NUMBER ⁽²⁾	SYMBOL
-40°C to 85°C	16-ball WCSP, 2,1mm x 2,1 mm (+ 0,01 / -0,09 mm)	TPA2100P1YZHR	CEH
		TPA2100P1YZHT	

- (1) For the most current package and ordering information see the Package Option Addendum at the end of this document, or see the TI website at www.ti.com.
- (2) The YZH package is only available taped and reeled. The suffix "R" indicates a reel of 3000; the suffix "T" indicates a reel of 250.

RECOMMENDED OPERATING CONDITIONS

			MIN	MAX	UNIT
Supply voltage	V_{DD}		2.5	5.5	V
Output voltage range	V_{ccIN}, V_{ccOUT}		9.5	10.5	V
V_{IH}	High-level input voltage	$\overline{SD}, \overline{SDa}$	1.3		V
V_{IL}	Low-level input voltage	$\overline{SD}, \overline{SDa}$		0.6	V
I_{IH}	High-level input current	$\overline{SD}, \overline{SDa}, V_{DD} = 2.5\text{ V to }5.5\text{ V}$		1	μA
I_{IL}	Low-level input current	$\overline{SD}, \overline{SDa}, V_{DD} = 2.5\text{ V to }5.5\text{ V}$		1	μA
f_{OSC}	Oscillator frequency		1.1	1.3	MHz
T_A	Operating free-air temperature		-40	85	$^{\circ}\text{C}$

ELECTRICAL CHARACTERISTICS

$T_A = 25^{\circ}\text{C}$, $\overline{SD} \geq 1.3\text{ V}$, GAIN = 12 dB, LOAD = 10 Ω +1 μF + 33 μH (unless otherwise noted)

PARAMETER		TEST CONDITIONS	MIN	TYP	MAX	UNIT
V_{DD}	Supply voltage range		2.5	3.6	5.5	V
I_{SD}	Shutdown quiescent current	$\overline{SD} \leq 0.35\text{ V}, V_{DD} = 2.5\text{ V to }5.5\text{ V}$		0.5	1	μA
I_{DD}	Supply current	$V_{DD} = 3.0\text{ V}$		6	9	mA
		$V_{DD} = 3.6\text{ V}$		5.5	8	
		$V_{DD} = 5.5\text{ V}$		4	5	
f_{SW}	Class-D switching frequency		250	300	350	kHz
f_{BOOST}	Boost converter switching frequency		1.1	1.2	1.3	MHz
POR	Power on reset on threshold			2.2		V
POR	Power on reset hysteresis			0.2		V
CMR	Input common mode range	$V_{IN} = \pm 100\text{ mV}, V_{DD} = 2.5\text{ V}$	0.5		2.0	V
		$V_{IN} = \pm 100\text{ mV}, V_{DD} = 3.6\text{ V}$	0.5		2.7	
		$V_{IN} = \pm 100\text{ mV}, V_{DD} = 5.5\text{ V}$	0.5		2.7	
V_{OOS}	Output offset voltage	$V_{DD} = 3.6\text{ V}, A_v = 12\text{ dB}, \text{inputs ac grounded}$		1.4	5	mV
Z_{OUT}	Output Impedance in shutdown mode	$\overline{SD} \leq 0.35\text{ V}$		2		k Ω
A_v	Gain	GAIN $\leq 0.35\text{ V}$	11.3	11.8	12.3	dB
		$0.7\text{ V} \leq \text{GAIN} \leq 1\text{ V}$	15.5	16	16.5	
		GAIN $\geq 1.35\text{ V}$	23.5	24	24.5	

OPERATING CHARACTERISTICS

$T_A = 25^\circ\text{C}$, $V_{DD} = 3.6\text{ V}$, $\overline{SD} = \overline{SDa} = 1.3\text{ V}$, Gain = 12 dB, Load = $10\ \Omega + 1\ \mu\text{F} + 22\ \mu\text{H}$ (unless otherwise noted)

PARAMETER	TEST CONDITIONS	MIN	TYP	MAX	UNIT
V_{OUTMAX}	Maximum output voltage swing THD+N = 1%, $V_{DD} = 3.0\text{ V}$, $L = 4.7\ \mu\text{H}$, $f_{AUD_IN} \leq 10\text{ kHz}$		19		V_{PP}
THD+N	Total harmonic distortion plus noise $f_{AUD_IN} = 1\text{ kHz}$; $V_{OUT} = 10\text{ to }18\ V_{P-P}$		0.07%		
k_{SVR}	Supply ripple rejection ratio 200 mV _{PP} supply ripple at 217 Hz		-100		dB
CMRR	Input common mode rejection $R_L = 8\ \Omega$, $V_{icm} = 0.5\text{V}$ and $V_{icm} = V_{DD} - 0.8\text{ V}$, differential inputs shorted		-60		dB
Z_{IN}	Input impedance $A_v = 12\text{ dB}$		23.2		k Ω
		$A_v = 16\text{ dB}$	18.5		
		$A_v = 24\text{ dB}$	10		
SNR	Signal to noise ratio $f = 20\text{ to }20\text{ kHz}$, $V_{OUT} = 6\ V_{RMS}$, $A_v = 12\text{ dB}$, A-weighted		94		dB
t_{ON}	Start up time (Class-D and Boost converter) $2.5\text{ V} \leq V_{DD} \leq 5.5\text{ V}$, no turn-on pop, $C_{IN} \leq 1\ \mu\text{F}$		8		ms

TYPICAL CHARACTERISTICS

$T_A = 25^\circ\text{C}$, $V_{DD} = 3.6\text{ V}$, Gain = 12 dB, $C_{IN} = 1\ \mu\text{F}$, $L_{BOOST} = 4.7\ \mu\text{H}$, $C_{BOOST} = 10\ \mu\text{F}$, $\overline{SD} = \overline{SDa} = 3.6\text{ V}$, Load = $10\ \Omega + 1\ \mu\text{F} + 22\ \mu\text{H}$ (unless otherwise noted)

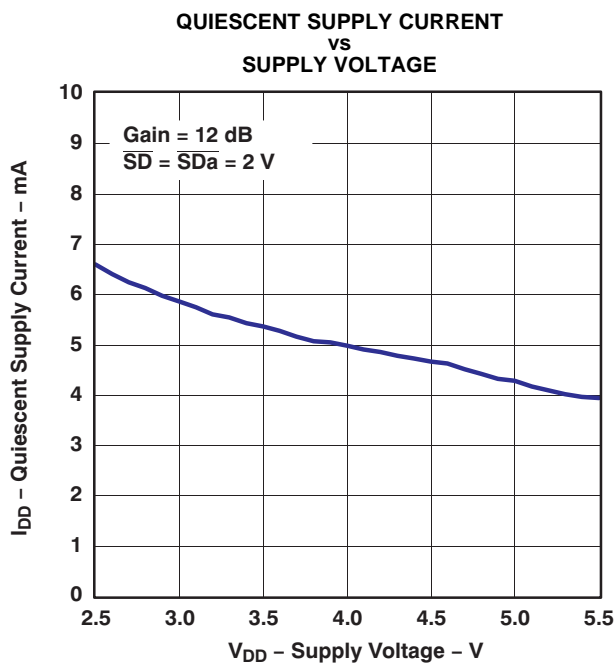

Figure 1.

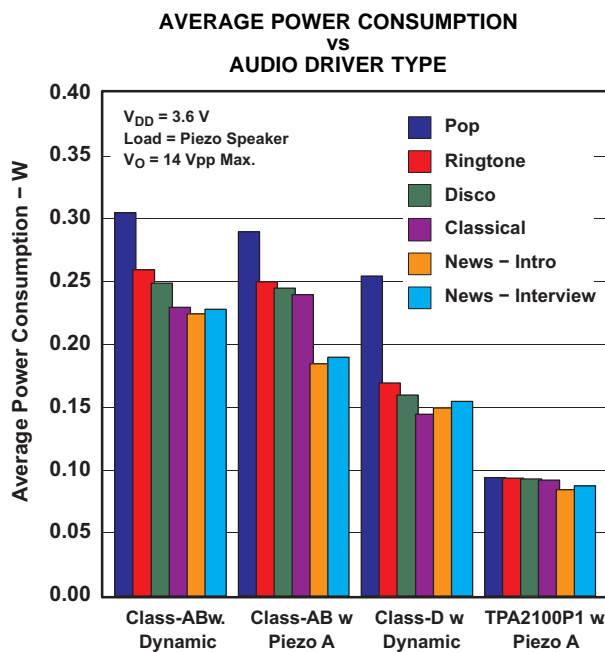

Figure 2.

TYPICAL CHARACTERISTICS (continued)

$T_A = 25^\circ\text{C}$, $V_{DD} = 3.6\text{ V}$, Gain = 12 dB, $C_{IN} = 1\ \mu\text{F}$, $L_{BOOST} = 4.7\ \mu\text{H}$, $C_{BOOST} = 10\ \mu\text{F}$, $\overline{SD} = \overline{SDa} = 3.6\text{ V}$, Load = $10\ \Omega + 1\ \mu\text{F} + 22\ \mu\text{H}$ (unless otherwise noted)

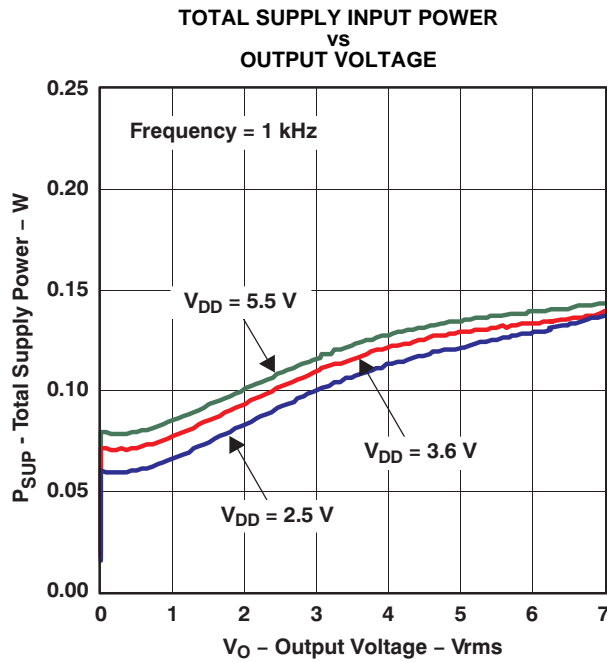

Figure 3.

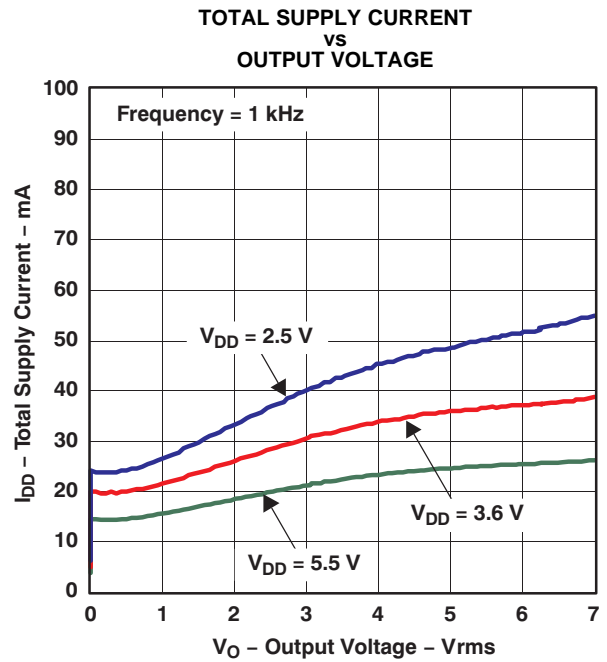

Figure 4.

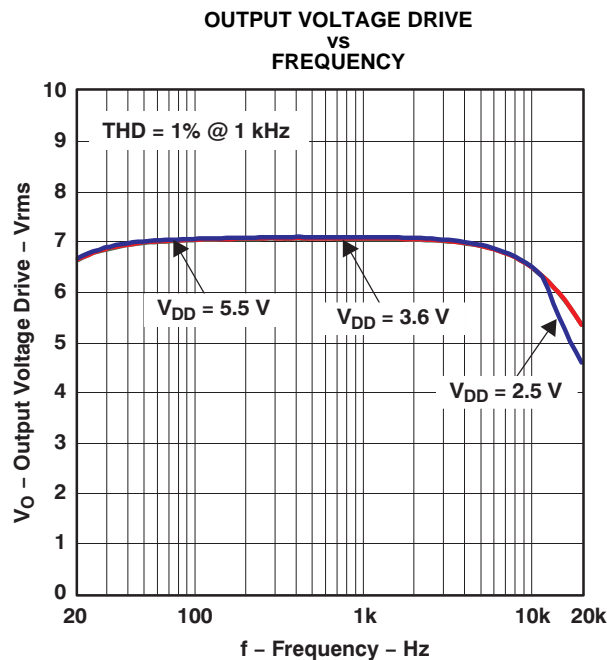

Figure 5.

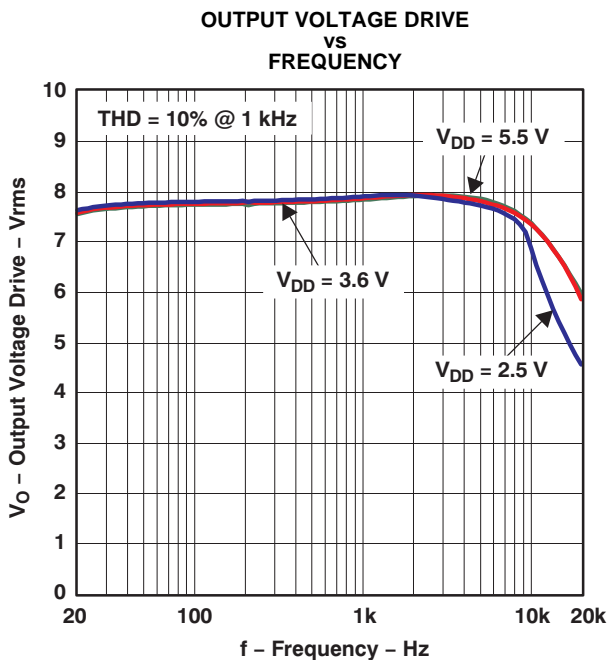

Figure 6.

TYPICAL CHARACTERISTICS (continued)

$T_A = 25^\circ\text{C}$, $V_{DD} = 3.6\text{ V}$, Gain = 12 dB, $C_{IN} = 1\ \mu\text{F}$, $L_{BOOST} = 4.7\ \mu\text{H}$, $C_{BOOST} = 10\ \mu\text{F}$, $\overline{SD} = \overline{SDa} = 3.6\text{ V}$, Load = $10\ \Omega + 1\ \mu\text{F} + 22\ \mu\text{H}$ (unless otherwise noted)

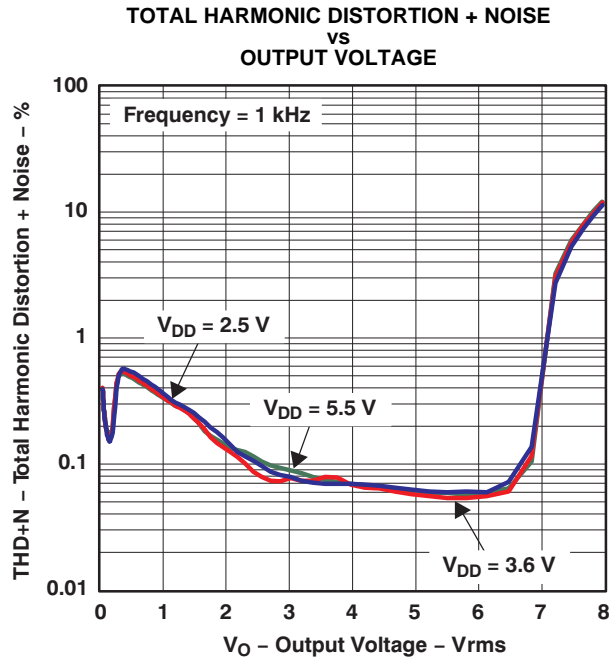

Figure 7.

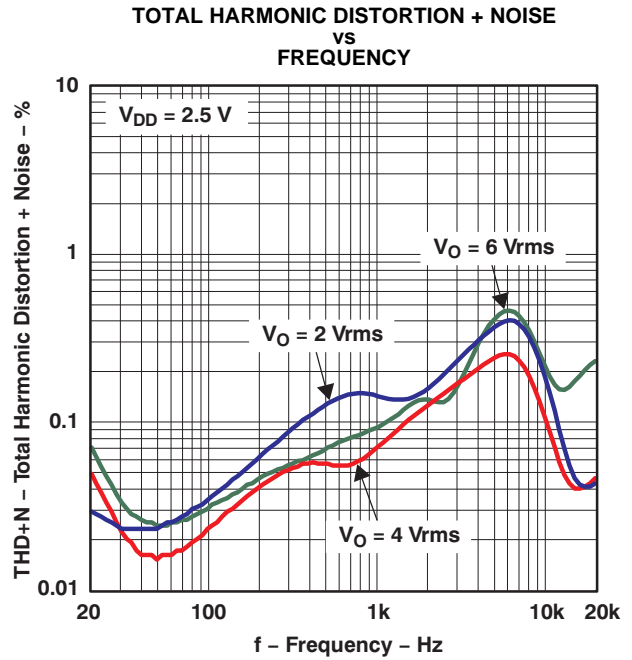

Figure 8.

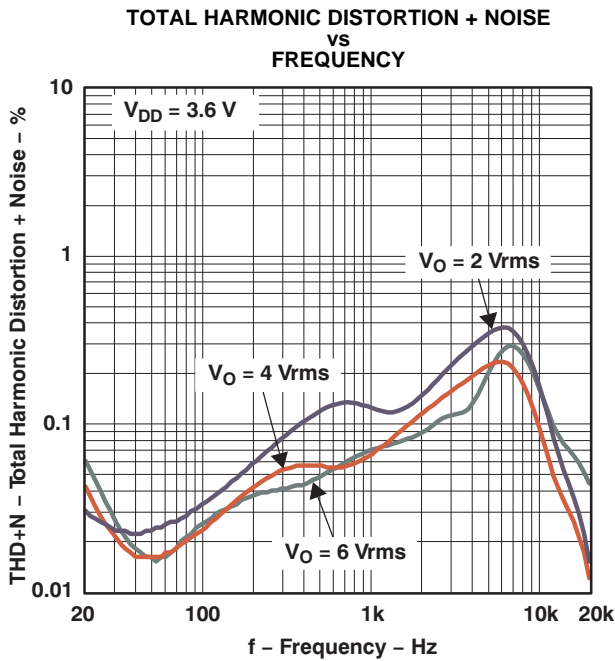

Figure 9.

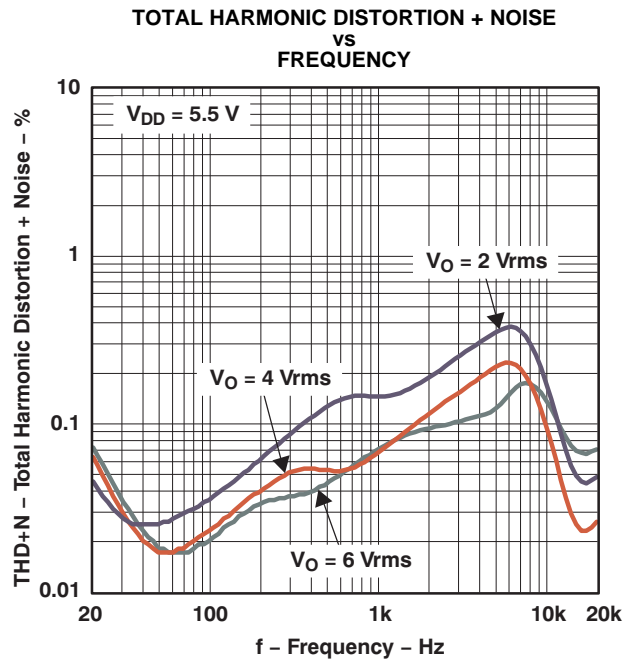

Figure 10.

TYPICAL CHARACTERISTICS (continued)

$T_A = 25^\circ\text{C}$, $V_{DD} = 3.6\text{ V}$, Gain = 12 dB, $C_{IN} = 1\ \mu\text{F}$, $L_{BOOST} = 4.7\ \mu\text{H}$, $C_{BOOST} = 10\ \mu\text{F}$, $\overline{SD} = \overline{SDa} = 3.6\text{ V}$, Load = $10\ \Omega + 1\ \mu\text{F} + 22\ \mu\text{H}$ (unless otherwise noted)

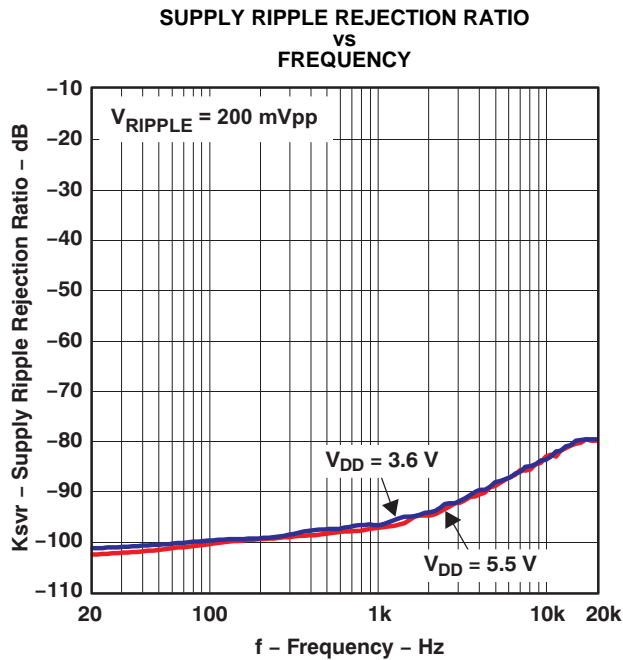

Figure 11.

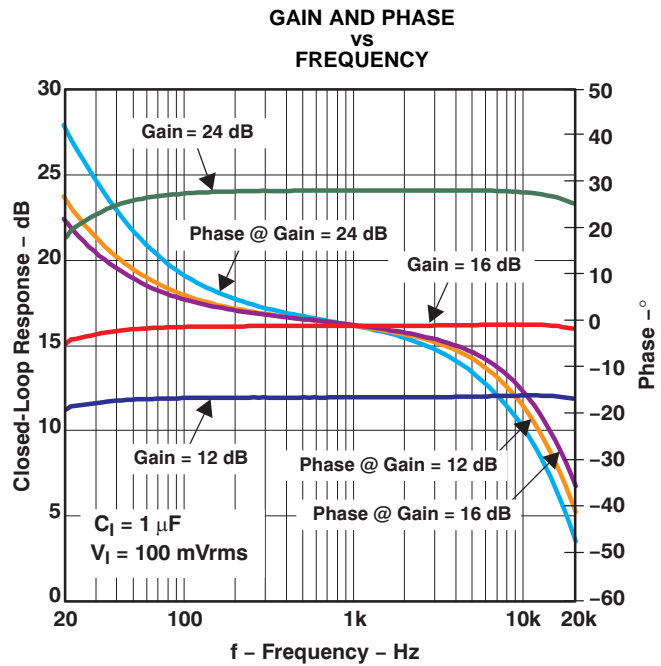

Figure 12.

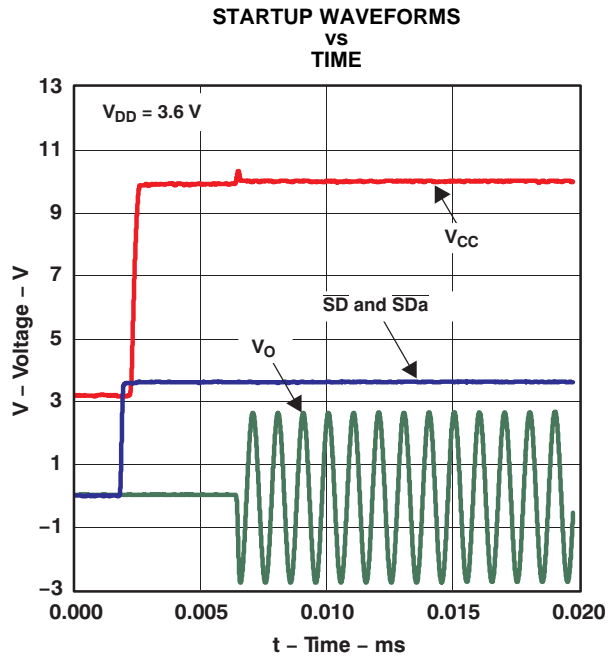

Figure 13.

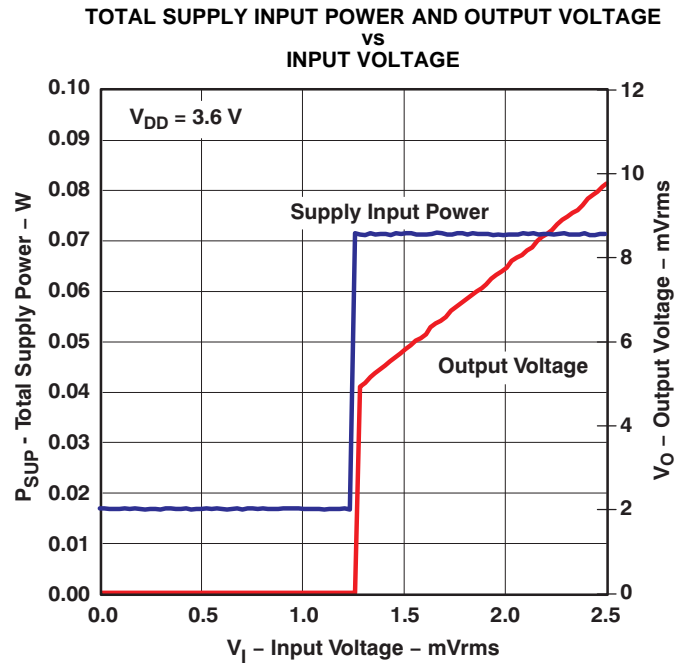

Figure 14.

APPLICATION INFORMATION

The TPA2100P1 consists of a boost converter and a Class-D amplifier. The boost converter takes a low supply voltage, VDD, and increases it to a higher output voltage, V_{CC}OUT. V_{CC}IN is the power supply for the Class-D amplifier. Connect V_{CC}OUT to V_{CC}IN.

FULLY DIFFERENTIAL CLASS-D AUDIO POWER AMPLIFIER

The TPA2100P1 is a fully differential amplifier. The fully differential amplifier includes a differential amplifier with common-mode feedback. The differential output is equal to the differential input times the gain. The common-mode feedback ensures that the common-mode voltage at the output is biased around V_{CC}/2 (Class-D supply voltage, V_{CC}OUT, divided by 2) regardless of the common-mode voltage at the input. The fully differential TPA2100P1 can still be used with a single-ended input; however, the TPA2100P1 should be used with differential inputs when in a noisy environment, like a wireless handset, to ensure maximum noise rejection.

- Input-coupling capacitors are not required:
 - The TPA2100P1 inputs can be biased anywhere within the common mode input voltage range listed in the Recommended Operating Conditions table. If the inputs are biased outside of that range, then input-coupling capacitors are required.
- Mid-supply bypass capacitor, C_{BYPASS}, is not required:
 - The fully differential amplifier does not require a bypass capacitor. Any shift in the midsupply affects both positive and negative channels equally and cancels at the differential output.
- Excellent RF-immunity and supply noise rejection:
 - GSM handsets save power by turning on and off the RF transmitter at 217 Hz. The transmitted signal is picked-up on input, output, and power supply traces. The fully differential amplifier cancels the signal better than a typical audio amplifier.

DRIVING A CERAMIC/PIEZO SPEAKER

Applications that require thin cases, such as mobile phones, demand that external components have a small form factor. Dynamic loudspeakers that use a cone and voice coil typically cannot conform to the height requirements. The option for these applications is to use a ceramic/piezoelectric loudspeaker.

Ceramic speakers have a capacitive behavior unlike a conventional loudspeaker, which has an inductive behavior. Typical capacitance values for ceramic/piezo speakers are as high as 2 μF. High peak-to-peak voltage drive is required to achieve acceptable sound pressure levels. Ceramic/piezo speakers have low current consumption at frequencies up to 8 kHz. The impedance of the ceramic/piezo speaker decreases with increasing audio frequency, thus requiring higher current as the frequency increases. However, audio signals in this range are higher harmonics of lower fundamentals, so the current demand is still small when compared to dynamic speaker current consumption.

Due to these characteristics, ceramic/piezo speakers are efficient in converting electrical audio signals into sound pressure in the mid and high audio bands (starting at 900 Hz).

The TPA2100P1 overcomes the challenges of driving a ceramic/piezo speaker. The TPA2100P1 drives the ceramic/piezo speaker with a constant output voltage over the battery life and across the audio frequency range.

LOAD CONFIGURATION

The TPA2100P1 can be configured in several different ways to drive a ceramic/piezo speaker. The most obvious configuration is to place a resistor on each output of the Class-D amplifier. A more efficient configuration is to replace one resistor with an inductor at one of the outputs. A third way to configure is to place just one resistor between the output and the speaker and connect the other output directly to the speaker.

For proper configuration of the load, it is important to observe the following variables:

- Speaker capacitance – C_{SPK}
- Maximum available current from the Boost converter – I_{BOOSTMAX}
- Highest desired audio frequency – f_{AUDMAX}
- Maximum voltage allowed across the speaker – V_{OUTPEAK}
- Peak Output Current from the Class-D Amplifier – I_{CLASSDPEAK}

RESISTOR – SPEAKER – RESISTOR LOAD CONFIGURATION

This is the simplest configuration. However, this type of load configuration does not achieve the best efficiency possible. Thus, it is recommended to use the resistor – speaker – inductor load configuration. The following figure shows an example of the resistor – speaker – resistor configuration.

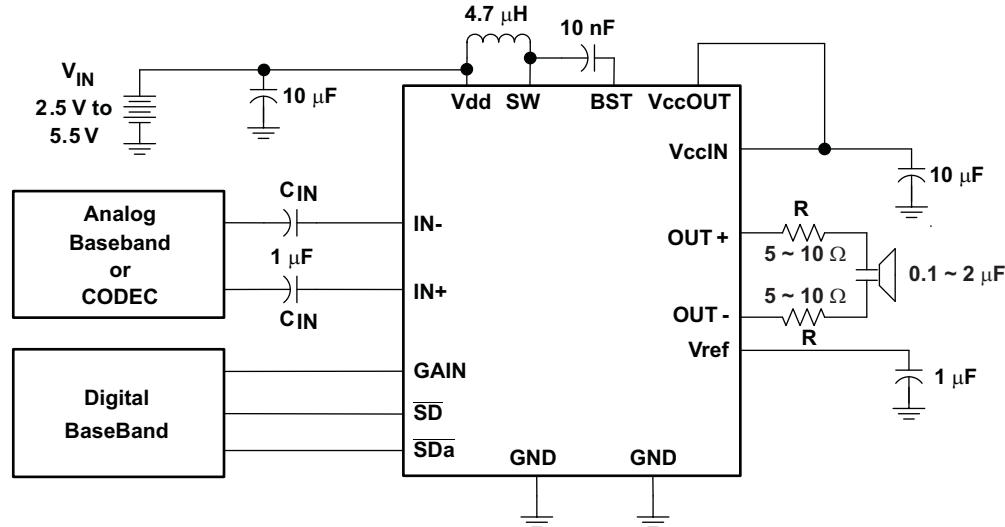

Figure 15. Application Schematic with Resistor – Speaker – Resistor Load Configuration

For the RC load configuration, only two calculations are required. Note that R in Equation 1 is the sum of the two output resistors in Figure 15.

The highest desired audio frequency will be limited by the RC low-pass filter configuration of the load:

$$f_{\text{AUDMAX}} = \frac{1}{2 \times \pi \times R \times C_{\text{SPK}}} \tag{1}$$

Peak Output Current from the Class-D Amplifier should therefore be limited to the maximum audio frequency:

$$I_{\text{CLASSDPEAK}} = \frac{V_{\text{OUTPEAK}}}{\sqrt{R^2 + XC^2}} \tag{2}$$

Where XC is:

$$XC = \frac{1}{2 \times \pi \times f_{\text{AUDMAX}} \times C_{\text{SPK}}} \tag{3}$$

To calculate the proper boost converter inductor required for this application, see the *Inductor Selection* section.

Note that an input low-pass filter should be added before the audio amplifier in order to limit the audio frequency, f_{AUDMAX} .

RESISTOR – SPEAKER – INDUCTOR LOAD CONFIGURATION

The second configuration with a resistor – speaker – inductor load is the most efficient configuration and is the preferred solution. Figure 16 shows an example of this configuration.

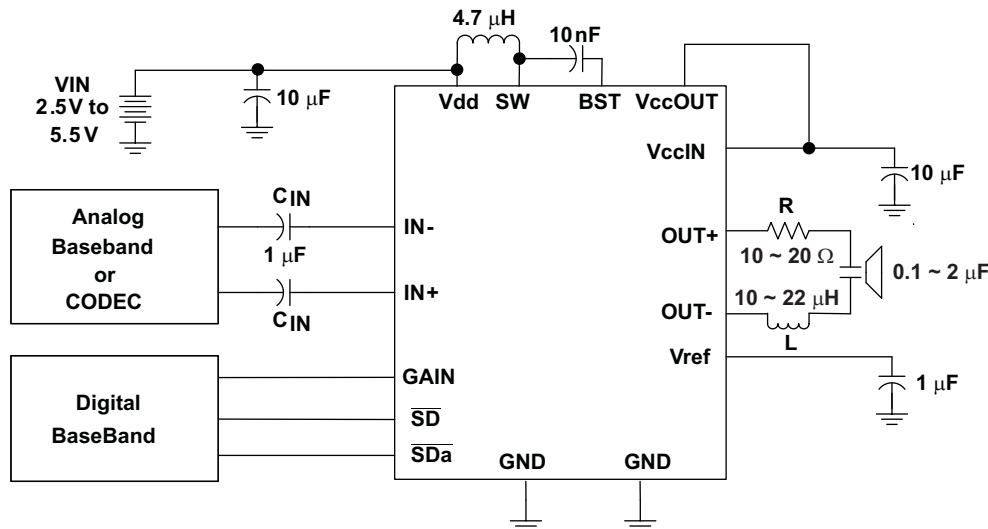

Figure 16. Application Schematic with Resistor – Speaker – Inductor Load Configuration

For the resistor – speaker – inductor load configuration, it is desired to make the output load configuration overdamped (Zeta (ζ) > 0.707). Use Equation 4 to calculate ζ :

$$\zeta = \frac{R \times \sqrt{C_{SPK}}}{2 \times \sqrt{L}} \quad (4)$$

If ζ is greater than one, then the maximum audio frequency will be limited by the resistor – speaker capacitance low pass filter as shown in Equation 5.

$$f_{AUDMAX} = \frac{1}{2 \times \pi \times R \times C_{SPK}} \quad (5)$$

Calculate equivalent load impedance with Equation 6, through Equation 9.

$$X_C = \frac{1}{2 \times \pi \times f_{AUDMAX} \times C_{SPK}} \quad (6)$$

$$X_L = 2 \times \pi \times f_{AUDMAX} \times L \quad (7)$$

$$Z = \sqrt{R^2 + (X_L - X_C)^2} \quad (8)$$

$$I_{CLASSDPEAK} = \frac{V_{OUTPEAK}}{Z} \quad (9)$$

To calculate the proper boost converter inductor required for this application, see the *Inductor Selection* section.

Note that an input low pass filter should be added before the audio amplifier in order to limit the audio frequency, f_{AUDMAX} .

RESISTOR – SPEAKER LOAD CONFIGURATION

This load configuration is similar to the resistor – speaker – resistor load configuration. Apply the same equations here to calculate the maximum audio frequency and maximum required current from the class-D audio amplifier.

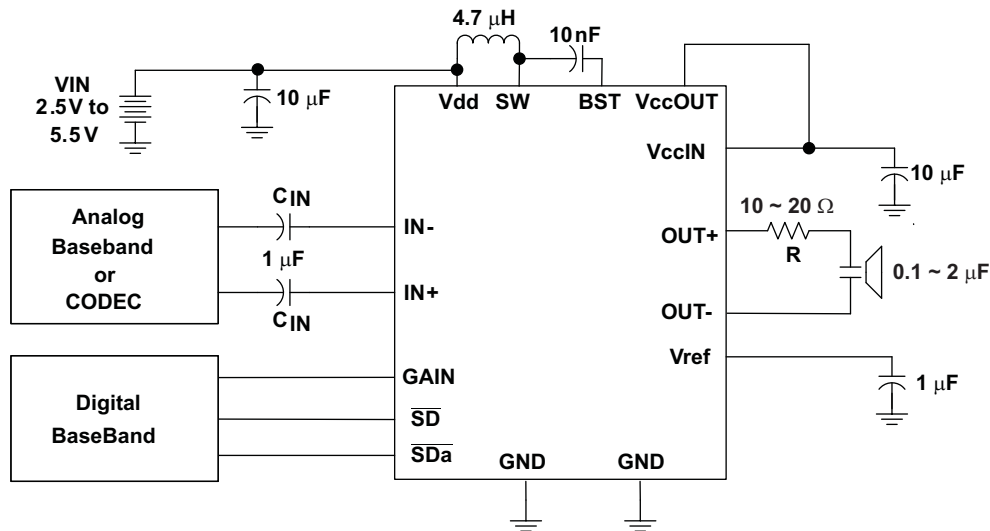

Figure 17. Application Schematic with Resistor – Speaker Load Configuration

BOOST CONVERTER

There are two main passive components necessary for the functioning of a boost converter. The boost inductor stores current, and the boost capacitor stores charge. When the Class-D amplifier depletes the charge in the boost capacitor, the boost inductor charges it back up with the stored current. The cycle of charge/discharge occurs at a frequency of f_{boost} .

The following is a list of terms and definitions used in the boost equations found in this document.

C	Minimum boost capacitance required for a given ripple voltage on V_{CC}
L	Boost inductor
f_{BOOST}	Switching frequency of the boost converter.
I_{CC}	Current pulled by the Class-D amplifier from the boost converter.
I_L	Average current through the boost inductor.
V_{CC}	Boost voltage. Generated by the boost converter ($V_{CC}OUT$). Voltage supply for the Class-D amplifier ($V_{CC}IN$).
V_{DD}	Supply voltage to the IC.
ΔI_L	Ripple current through the inductor.
ΔV	Ripple voltage of V_{CC} due to capacitance. V_{CC} is the voltage on the $V_{CC}OUT$ and $V_{CC}IN$ pins.

INDUCTOR SELECTION

SURFACE MOUNT INDUCTORS

Working inductance decreases as inductor current increases. If the drop in working inductance is severe enough, it may cause the boost converter to become unstable, or cause the TPA2100P1 to reach its current limit at a lower output voltage than expected. Inductor vendors specify currents at which inductor values decrease by a specific percentage. This can vary by 10% to 35%. Inductance is also affected by dc current and temperature.

TPA2100P1 INDUCTOR EQUATIONS

Inductor current rating is determined by the requirements of the load. The inductance is determined by two factors: the minimum value required for stability and the maximum ripple current permitted in the application.

Use [Equation 10](#) to determine the required current rating. [Equation 10](#) shows the approximate relationship between the average inductor current, I_L , to the load current, load voltage, and input voltage (I_{CC} , V_{CC} , and V_{DD} , respectively). Insert I_{CC} , V_{CC} , and V_{DD} into [Equation 10](#) to solve for I_L . The inductor must maintain at least 90% of its initial inductance value at this current.

$$I_L = I_{CC} \times \left(\frac{V_{CC}}{V_{DD} \times 0.8} \right) \quad (10)$$

The minimum working inductance is 3.3μH. A lower value may cause instability.

Ripple current, ΔI_L , is peak-to-peak variation in inductor current. Smaller ripple current reduces core losses in the inductor as well as the potential for EMI. Use [Equation 11](#) to determine the value of the inductor, L. [Equation 11](#) shows the relationship between inductance L, V_{DD} , V_{CC} , the switching frequency, f_{BOOST} , and ΔI_L . Insert the maximum acceptable ripple current into [Equation 11](#) to solve for L.

$$L = \frac{V_{DD} \times (V_{CC} - V_{DD})}{\Delta I_L \times f_{boost} \times V_{CC}} \quad (11)$$

ΔI_L is inversely proportional to L. Minimize ΔI_L as much as is necessary for a specific application. Increase the inductance to reduce the ripple current. Note that making the inductance value of L greater than 10 μH will prevent the boost converter from responding to fast load changes properly. A typical inductor value for the TPA2100P1 is 4.7 μH.

Select an inductor with a dc resistance, DCR, no greater than 0.5 Ω. DCR reduces the amount of power the device receives from the supply due to the voltage drop across the inductor.

CAPACITOR SELECTION

SURFACE MOUNT CAPACITORS

Temperature and applied dc voltage influence the actual capacitance of high-K materials.

[Table 1](#) shows the relationship between the different types of high-K materials and their associated tolerances, temperature coefficients, and temperature ranges. Notice that a capacitor made with X5R material can lose up to 15% of its capacitance within its working temperature range.

Table 1. Typical Tolerance and Temperature Coefficient of Capacitance by Material

MATERIAL	COG/NPO	X7R	X5R
Typical tolerance	±5%	±10%	±20%
Temperature Coefficient	±30 ppm	±15%	±15%
Temperature range, °C	-55/125°C	-55/125°C	-55/85°C

High-K material is very sensitive to applied dc voltage. X5R capacitors can have losses ranging from 15% to 45% of their initial capacitance with only half of their dc rated voltage applied. For example, if 5 Vdc is applied to a 10 V, 1 μF X5R capacitor, the measured capacitance at that point may show between 0.55 μF and 0.85 μF. Y5V capacitors have losses that can reach or exceed 50% to 75% of their rated value.

The working capacitance of components made with high-K materials is generally much lower than nominal capacitance. A worst case result with a typical X5R material might be -10% tolerance, -15% temperature effect, and -45% dc voltage effect at 50% of the rated voltage. This particular case would result in a working capacitance of 42% ($0.9 \times 0.85 \times 0.55$) of the nominal value.

Select high-K ceramic capacitors according to the following rules:

1. Use capacitors made of materials with temperature coefficients of X5R, X7R, or better.
2. Use capacitors with dc voltage ratings of at least twice the application voltage, because high-K capacitor values generally are reduced by DC voltage. 25V capacitors are recommended when boost converter output is 10V. The minimum rating that should be used in this case is 16V, but correct operation should be verified carefully.
3. Choose a capacitance value at least twice the nominal value calculated for the application. Multiply the nominal value by a factor of 2 for safety. If a 10 μF capacitor is required, use 22 μF.

The preceding rules and recommendations apply to capacitors used in connection with the TPA2100P1. The TPA2100P1 cannot meet its performance specifications if the rules and recommendations are not followed.

TPA2100P1 CAPACITOR EQUATIONS

The value of the boost capacitor is determined by the minimum value of working capacitance required for stability and the maximum voltage ripple allowed on V_{CC} in the application. The minimum value of working capacitance is 10 μF . Do not use any component with a working capacitance less than 10 μF .

For X5R or X7R ceramic capacitors, [Equation 12](#) shows the relationship between the boost capacitance, C , to load current, load voltage, ripple voltage, input voltage, and switching frequency (I_{CC} , V_{CC} , ΔV , V_{DD} , f_{BOOST} respectively).

Insert the maximum allowed ripple voltage into [Equation 12](#) to solve for C . A factor of 2 is included to implement the rules and specifications listed earlier.

$$C = 2 \times \frac{I_{CC} \times (V_{CC} - V_{DD})}{\Delta V \times f_{boost} \times V_{CC}} \quad (12)$$

For aluminum or tantalum capacitors, [Equation 13](#) shows the relationship between the boost capacitance, C , to load current, load voltage, ripple voltage, input voltage, and switching frequency (I_{CC} , V_{CC} , ΔV , V_{DD} , f_{BOOST} respectively). Insert the maximum allowed ripple voltage into [Equation 12](#) to solve for C . Solve this equation assuming ESR is zero.

$$C = \frac{I_{CC} \times (V_{CC} - V_{DD})}{\Delta V \times f_{boost} \times V_{CC}} \quad (13)$$

Capacitance of aluminum and tantalum capacitors is normally not sensitive to applied voltage so there is no factor of 2 included in [Equation 4](#). However, the ESR in aluminum and tantalum capacitors can be significant. Choosing an aluminum or tantalum capacitor with ESR around 30 m Ω is acceptable.

Decoupling Capacitors

The TPA2100P1 is a high-performance Class-D audio amplifier that requires adequate power supply decoupling to ensure the efficiency is high and total harmonic distortion (THD) is low. In addition to the 10 μF capacitor at V_{DD} , place a 1 μF low ESR capacitor within 1 mm of the V_{DD} pin to reduce higher frequency transients, spikes, or digital hash on the line. For the same reasons place a 1 μF low ESR capacitor within 1 mm of the V_{CCOUT} pin in addition to the boost output capacitor.

Input Capacitors, C_I

The TPA2100P1 does not require input coupling capacitors if the design uses a low offset differential source that is biased within the common mode input voltage range. Note that source offset is amplified if no DC blocking capacitors are used. If the input signal is not biased within the recommended common-mode input range, if high pass filtering is needed, or if using a single-ended source, input coupling capacitors are required.

The input capacitors and input resistors form a high-pass filter with the corner frequency, f_C , determined in [Equation 14](#).

$$f_C = \frac{1}{(2\pi \times R_I \times C_I)} \quad (14)$$

The value of the input capacitor directly affects the bass (low frequency) performance of the circuit. Piezo speakers cannot usually respond well to low frequencies, so the corner frequency can be set to block low frequencies and reduce speaker distortion in this application. Not using input capacitors can increase output offset.

Use [Equation 15](#) to solve for the input coupling capacitance. If the corner frequency is within the audio band, the input capacitors should have a tolerance of $\pm 10\%$ or better, because any mismatch in capacitance causes an impedance mismatch at the corner frequency and below.

$$C_1 = \frac{1}{(2\pi \times R_1 \times f_C)} \tag{15}$$

BOARD LAYOUT

In making the pad size for the WCSP balls, it is recommended that the layout use nonsolder mask defined (NSMD) land. With this method, the solder mask opening is made larger than the desired land area, and the opening size is defined by the copper pad width. Figure 18 and Table 2 shows the appropriate diameters for a WCSP layout.

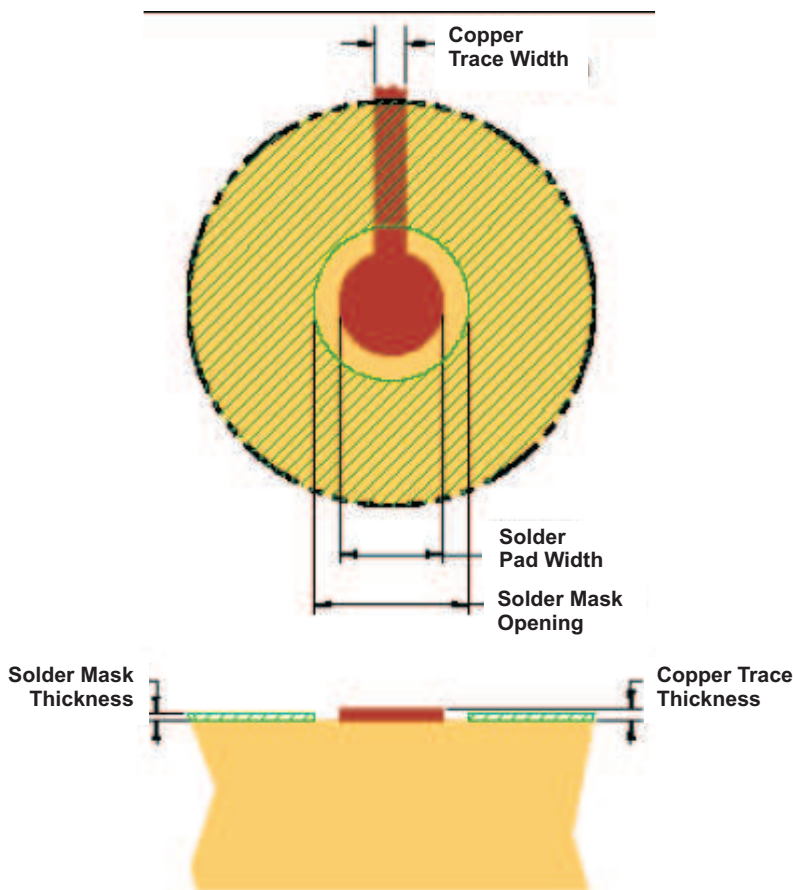

Figure 18. Land Pattern Dimensions

Table 2. Land Pattern Dimensions^{(1) (2) (3) (4)}

SOLDER PAD DEFINITIONS	COPPER PAD	SOLDER MASK ⁽⁵⁾ OPENING	COPPER THICKNESS	STENCIL ^{(6) (7)} OPENING	STENCIL THICKNESS
Nonsolder mask defined (NSMD)	275 μm (+0.0, -25 μm)	375 μm (+0.0, -25 μm)	1 oz max (32 μm)	275 μm × 275 μm Sq. (rounded corners)	125 μm thick

- (1) Circuit traces from NSMD defined PWB lands should be 75 μm to 100 μm wide in the exposed area inside the solder mask opening. Wider trace widths reduce device stand off and impact reliability.
- (2) Best reliability results are achieved when the PWB laminate glass transition temperature is above the operating the range of the intended application
- (3) Recommend solder paste is Type 3 or Type 4.
- (4) For a PWB using a Ni/Au surface finish, the gold thickness should be less 0,5 mm to avoid a reduction in thermal fatigue performance.
- (5) Solder mask thickness should be less than 20 μm on top of the copper circuit pattern
- (6) Best solder stencil performance is achieved using laser cut stencils with electro polishing. Use of chemically etched stencils results in inferior solder paste volume control.
- (7) Trace routing away from WCSP device should be balanced in X and Y directions to avoid unintentional component movement due to solder wetting forces.

Component Location

Place all the external components as close as possible to the TPA2100P1. Placing the decoupling capacitor as close as possible to the TPA2100P1 is important for the efficiency of the Class-D amplifier. Any resistance or inductance in the trace between the device and the capacitor can cause a loss in efficiency.

Trace Width

Recommended trace width at the solder balls is 75 μm to 100 μm to prevent solder wicking onto wider PCB traces.

For high current pins (SW, VccOUT, VccIN, GND, and audio output pins) of the TPA2100P1, use 100 μm trace widths at the solder balls and at least 500 μm PCB traces to ensure proper performance and output power for the device.

For the remaining signals of the TPA2100P1, use 75 μm to 100 μm trace widths at the solder balls. The audio input pins (IN- and IN+) must run side-by-side to maximize common-mode noise cancellation.

EFFICIENCY AND THERMAL INFORMATION

The maximum ambient temperature depends on the heat-sinking ability of the PCB system. The derating factor for the packages are shown in the dissipation rating table. Converting this to θ_{JA} for the WCSP package:

$$\theta_{JA} = \frac{1}{\text{Derating Factor}} = \frac{1}{0.0133} = 75^{\circ}\text{C/W} \quad (16)$$

Given θ_{JA} of 75 $^{\circ}\text{C/W}$, the maximum allowable junction temperature of 150 $^{\circ}\text{C}$, and the maximum estimated internal dissipation of 1 W (driving 1 μF speaker with 6 Vrms 15 kHz sine wave, the maximum ambient temperature is calculated with [Equation 17](#).

$$T_{A\text{Max}} = T_{J\text{Max}} - \theta_{JA}P_{D\text{max}} = 150 - 75(1) = 75^{\circ}\text{C} \quad (17)$$

[Equation 17](#) shows that the calculated maximum ambient temperature is 75 $^{\circ}\text{C}$ at maximum power dissipation. The TPA2100P1 is designed with thermal protection that turns the device off when the junction temperature surpasses 150 $^{\circ}\text{C}$ to prevent damage to the IC. Using the resistor- speaker - resistor or the resistor - speaker load configurations dramatically increases the temperature of the TPA2100P1 since those configurations require a much higher output current.

OPERATION WITH DACs AND CODECs

When using Class-D amplifiers with CODECs and DACs, sometimes there is an increase in the output noise floor from the audio amplifier. This occurs when the output frequencies of the CODEC/DAC mix with the switching frequencies of the audio amplifier input stage.

The TPA2100P1 has a built-in low-pass filter to reduce CODEC/DAC out-of-band noise that could mix with the switching frequency of the Class-D amplifier.

FILTER FREE OPERATION

A ferrite bead filter is not required for operation with the resistor – speaker – resistor load configuration or with the resistor – speaker – inductor load configuration. In order to achieve low radiated emissions, the resistor and/or inductor should be placed within 1 cm of the output of the amplifier and followed with a 100 pF to 1000 pF capacitor to GND. [Figure 19](#) and [Figure 20](#) show typical load configurations to reduce radiated emissions.

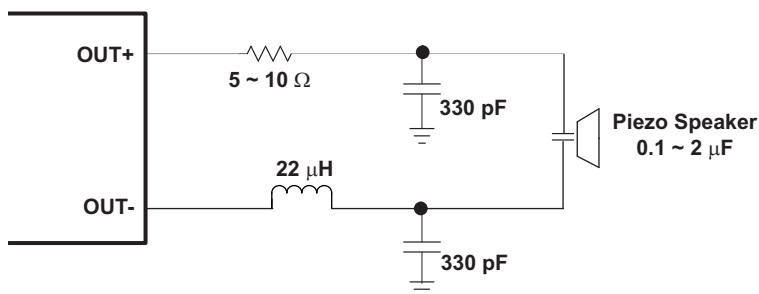

Figure 19. Typical Radiated Emissions Suppression Circuit (Resistor-Speaker-Inductor Load)

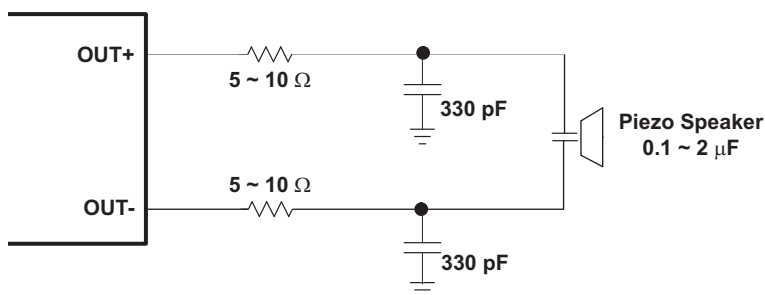

Figure 20. Typical Radiated Emissions Suppression Circuit (Resistor-Speaker-Resistor Load)

Figure 21 shows the EMC performance of Figure 19 using a 1 μF load to simulate the speaker. Table 3 list the measurement conditions. The worst-case quasi-peak margin is 14.4 dB at 55.9 MHz.

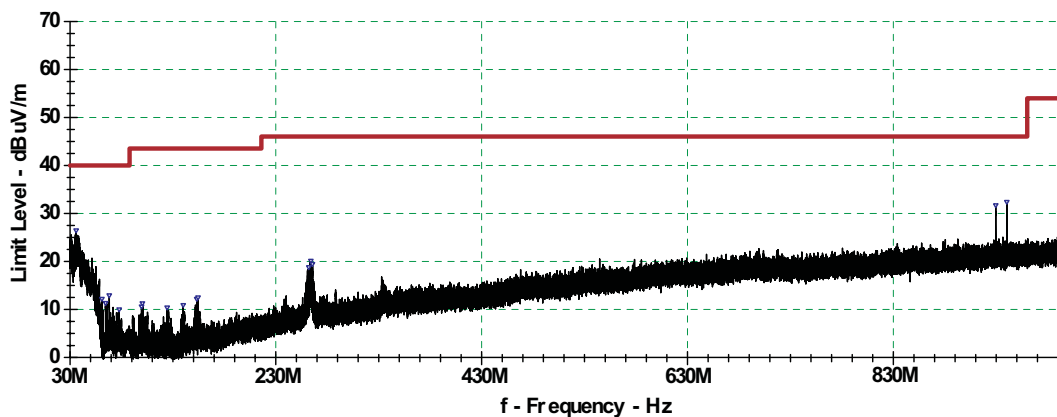

Figure 21. Measured Radiated Emissions – Vertical Front

Table 3. Measurement Conditions for Radiated Emissions of Figure 21

PARAMETER	VALUE	UNIT
V _{DD} Supply Voltage	3.6	V
A _V Gain	12	dB
f _{AUD} Input signal frequency	1	kHz
V _I Input signal amplitude	1.3	V _{RMS}
V _O Output signal amplitude	5.3	V _{RMS}
C _L Load capacitance	1	μF
Cable length	25.4	mm
Antenna position	Vertical Front	–

For a full Radiated Emissions report, please contact your local TI representative.

For operation with a resistor – speaker load configuration the ferrite bead filter can often be used if the design is failing radiated emissions without an LC filter and the frequency sensitive circuit is greater than 1 MHz. This filter functions well for circuits that just have to pass FCC and CE because FCC and CE only test radiated emissions greater than 30 MHz. When choosing a ferrite bead, choose one with high impedance at high frequencies, and very low impedance at low frequencies. In addition, select a ferrite bead with adequate current rating to prevent distortion of the output signal.

Figure 22 shows a typical ferrite bead output filter.

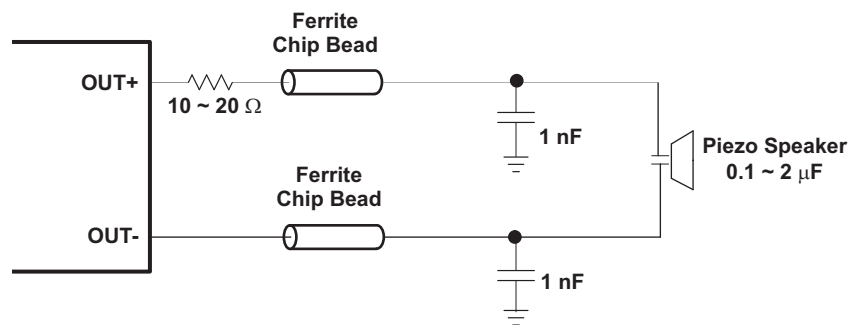



Figure 22. Typical Ferrite Bead Filter (Chip bead example: TDK: MPZ1608Y101B)

PACKAGING INFORMATION

Orderable Device	Status (1)	Package Type	Package Drawing	Pins	Package Qty	Eco Plan (2)	Lead/Ball Finish	MSL Peak Temp (3)	Op Temp (°C)	Top-Side Markings (4)	Samples
TPA2100P1YZHR	ACTIVE	DSBGA	YZH	16	3000	Green (RoHS & no Sb/Br)	SNAGCU	Level-1-260C-UNLIM		CEH	
TPA2100P1YZHT	ACTIVE	DSBGA	YZH	16	250	Green (RoHS & no Sb/Br)	SNAGCU	Level-1-260C-UNLIM		CEH	

(1) The marketing status values are defined as follows:

ACTIVE: Product device recommended for new designs.

LIFEBUY: TI has announced that the device will be discontinued, and a lifetime-buy period is in effect.

NRND: Not recommended for new designs. Device is in production to support existing customers, but TI does not recommend using this part in a new design.

PREVIEW: Device has been announced but is not in production. Samples may or may not be available.

OBSOLETE: TI has discontinued the production of the device.

(2) Eco Plan - The planned eco-friendly classification: Pb-Free (RoHS), Pb-Free (RoHS Exempt), or Green (RoHS & no Sb/Br) - please check <http://www.ti.com/productcontent> for the latest availability information and additional product content details.

TBD: The Pb-Free/Green conversion plan has not been defined.

Pb-Free (RoHS): TI's terms "Lead-Free" or "Pb-Free" mean semiconductor products that are compatible with the current RoHS requirements for all 6 substances, including the requirement that lead not exceed 0.1% by weight in homogeneous materials. Where designed to be soldered at high temperatures, TI Pb-Free products are suitable for use in specified lead-free processes.

Pb-Free (RoHS Exempt): This component has a RoHS exemption for either 1) lead-based flip-chip solder bumps used between the die and package, or 2) lead-based die adhesive used between the die and leadframe. The component is otherwise considered Pb-Free (RoHS compatible) as defined above.

Green (RoHS & no Sb/Br): TI defines "Green" to mean Pb-Free (RoHS compatible), and free of Bromine (Br) and Antimony (Sb) based flame retardants (Br or Sb do not exceed 0.1% by weight in homogeneous material)

(3) MSL, Peak Temp. -- The Moisture Sensitivity Level rating according to the JEDEC industry standard classifications, and peak solder temperature.

(4) Only one of markings shown within the brackets will appear on the physical device.

Important Information and Disclaimer: The information provided on this page represents TI's knowledge and belief as of the date that it is provided. TI bases its knowledge and belief on information provided by third parties, and makes no representation or warranty as to the accuracy of such information. Efforts are underway to better integrate information from third parties. TI has taken and continues to take reasonable steps to provide representative and accurate information but may not have conducted destructive testing or chemical analysis on incoming materials and chemicals. TI and TI suppliers consider certain information to be proprietary, and thus CAS numbers and other limited information may not be available for release.

In no event shall TI's liability arising out of such information exceed the total purchase price of the TI part(s) at issue in this document sold by TI to Customer on an annual basis.

TAPE AND REEL INFORMATION

QUADRANT ASSIGNMENTS FOR PIN 1 ORIENTATION IN TAPE

*All dimensions are nominal

Device	Package Type	Package Drawing	Pins	SPQ	Reel Diameter (mm)	Reel Width W1 (mm)	A0 (mm)	B0 (mm)	K0 (mm)	P1 (mm)	W (mm)	Pin1 Quadrant
TPA2100P1YZHR	DSBGA	YZH	16	3000	180.0	8.4	2.35	2.35	0.81	4.0	8.0	Q1
TPA2100P1YZHT	DSBGA	YZH	16	250	180.0	8.4	2.35	2.35	0.81	4.0	8.0	Q1

TAPE AND REEL BOX DIMENSIONS

*All dimensions are nominal

Device	Package Type	Package Drawing	Pins	SPQ	Length (mm)	Width (mm)	Height (mm)
TPA2100P1YZHR	DSBGA	YZH	16	3000	182.0	182.0	20.0
TPA2100P1YZHT	DSBGA	YZH	16	250	182.0	182.0	20.0

YZH (S-XBGA-N16)

DIE-SIZE BALL GRID ARRAY

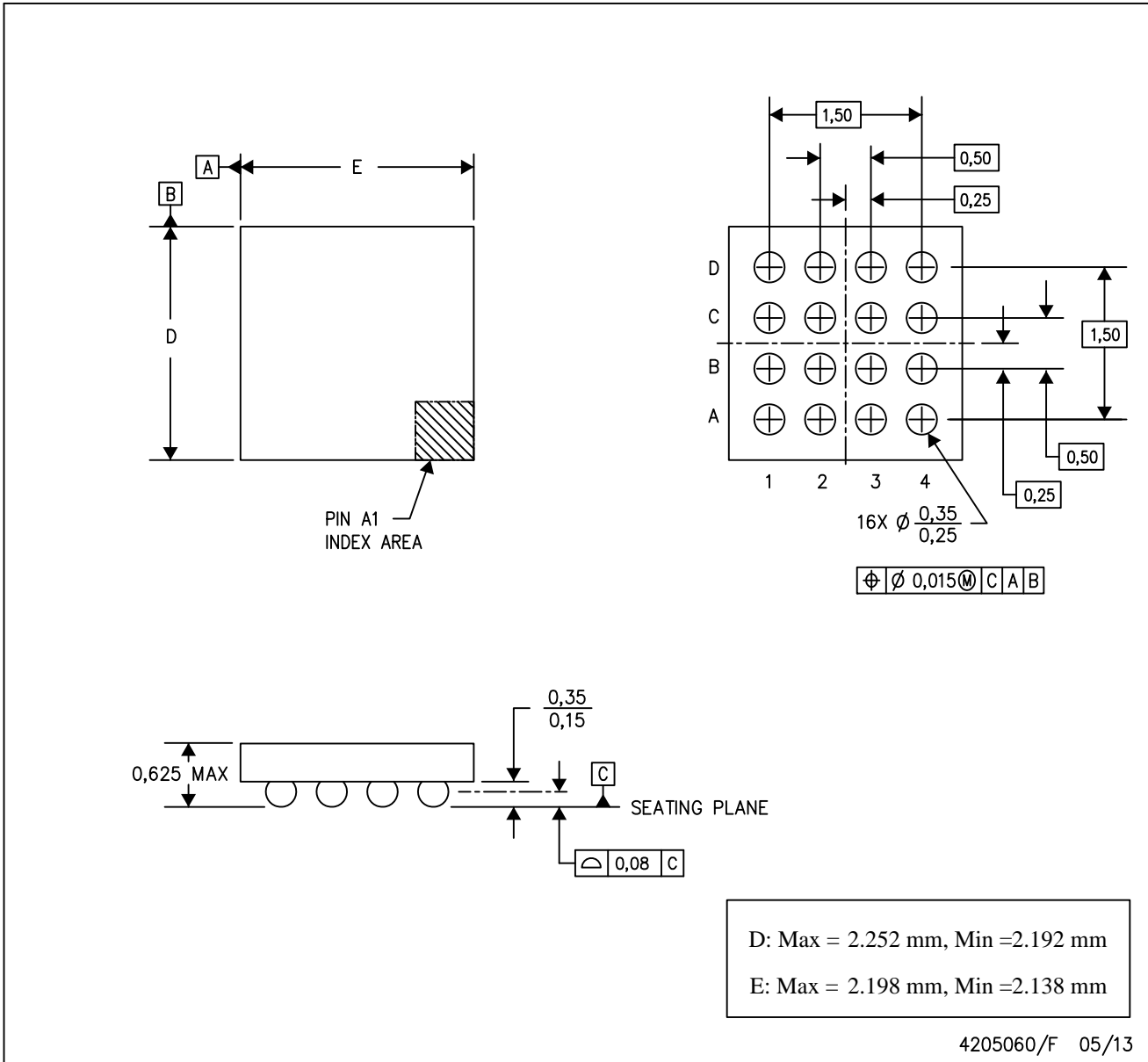

- NOTES:
- A. All linear dimensions are in millimeters.
 - B. This drawing is subject to change without notice.
 - C. NanoFree™ package configuration.

IMPORTANT NOTICE

Texas Instruments Incorporated (TI) reserves the right to make corrections, enhancements, improvements and other changes to its semiconductor products and services per JESD46, latest issue, and to discontinue any product or service per JESD48, latest issue. Buyers should obtain the latest relevant information before placing orders and should verify that such information is current and complete.

TI's published terms of sale for semiconductor products (<http://www.ti.com/sc/docs/stdterms.htm>) apply to the sale of packaged integrated circuit products that TI has qualified and released to market. Additional terms may apply to the use or sale of other types of TI products and services.

Reproduction of significant portions of TI information in TI data sheets is permissible only if reproduction is without alteration and is accompanied by all associated warranties, conditions, limitations, and notices. TI is not responsible or liable for such reproduced documentation. Information of third parties may be subject to additional restrictions. Resale of TI products or services with statements different from or beyond the parameters stated by TI for that product or service voids all express and any implied warranties for the associated TI product or service and is an unfair and deceptive business practice. TI is not responsible or liable for any such statements.

Buyers and others who are developing systems that incorporate TI products (collectively, "Designers") understand and agree that Designers remain responsible for using their independent analysis, evaluation and judgment in designing their applications and that Designers have full and exclusive responsibility to assure the safety of Designers' applications and compliance of their applications (and of all TI products used in or for Designers' applications) with all applicable regulations, laws and other applicable requirements. Designer represents that, with respect to their applications, Designer has all the necessary expertise to create and implement safeguards that (1) anticipate dangerous consequences of failures, (2) monitor failures and their consequences, and (3) lessen the likelihood of failures that might cause harm and take appropriate actions. Designer agrees that prior to using or distributing any applications that include TI products, Designer will thoroughly test such applications and the functionality of such TI products as used in such applications.

TI's provision of technical, application or other design advice, quality characterization, reliability data or other services or information, including, but not limited to, reference designs and materials relating to evaluation modules, (collectively, "TI Resources") are intended to assist designers who are developing applications that incorporate TI products; by downloading, accessing or using TI Resources in any way, Designer (individually or, if Designer is acting on behalf of a company, Designer's company) agrees to use any particular TI Resource solely for this purpose and subject to the terms of this Notice.

TI's provision of TI Resources does not expand or otherwise alter TI's applicable published warranties or warranty disclaimers for TI products, and no additional obligations or liabilities arise from TI providing such TI Resources. TI reserves the right to make corrections, enhancements, improvements and other changes to its TI Resources. TI has not conducted any testing other than that specifically described in the published documentation for a particular TI Resource.

Designer is authorized to use, copy and modify any individual TI Resource only in connection with the development of applications that include the TI product(s) identified in such TI Resource. NO OTHER LICENSE, EXPRESS OR IMPLIED, BY ESTOPPEL OR OTHERWISE TO ANY OTHER TI INTELLECTUAL PROPERTY RIGHT, AND NO LICENSE TO ANY TECHNOLOGY OR INTELLECTUAL PROPERTY RIGHT OF TI OR ANY THIRD PARTY IS GRANTED HEREIN, including but not limited to any patent right, copyright, mask work right, or other intellectual property right relating to any combination, machine, or process in which TI products or services are used. Information regarding or referencing third-party products or services does not constitute a license to use such products or services, or a warranty or endorsement thereof. Use of TI Resources may require a license from a third party under the patents or other intellectual property of the third party, or a license from TI under the patents or other intellectual property of TI.

TI RESOURCES ARE PROVIDED "AS IS" AND WITH ALL FAULTS. TI DISCLAIMS ALL OTHER WARRANTIES OR REPRESENTATIONS, EXPRESS OR IMPLIED, REGARDING RESOURCES OR USE THEREOF, INCLUDING BUT NOT LIMITED TO ACCURACY OR COMPLETENESS, TITLE, ANY EPIDEMIC FAILURE WARRANTY AND ANY IMPLIED WARRANTIES OF MERCHANTABILITY, FITNESS FOR A PARTICULAR PURPOSE, AND NON-INFRINGEMENT OF ANY THIRD PARTY INTELLECTUAL PROPERTY RIGHTS. TI SHALL NOT BE LIABLE FOR AND SHALL NOT DEFEND OR INDEMNIFY DESIGNER AGAINST ANY CLAIM, INCLUDING BUT NOT LIMITED TO ANY INFRINGEMENT CLAIM THAT RELATES TO OR IS BASED ON ANY COMBINATION OF PRODUCTS EVEN IF DESCRIBED IN TI RESOURCES OR OTHERWISE. IN NO EVENT SHALL TI BE LIABLE FOR ANY ACTUAL, DIRECT, SPECIAL, COLLATERAL, INDIRECT, PUNITIVE, INCIDENTAL, CONSEQUENTIAL OR EXEMPLARY DAMAGES IN CONNECTION WITH OR ARISING OUT OF TI RESOURCES OR USE THEREOF, AND REGARDLESS OF WHETHER TI HAS BEEN ADVISED OF THE POSSIBILITY OF SUCH DAMAGES.

Unless TI has explicitly designated an individual product as meeting the requirements of a particular industry standard (e.g., ISO/TS 16949 and ISO 26262), TI is not responsible for any failure to meet such industry standard requirements.

Where TI specifically promotes products as facilitating functional safety or as compliant with industry functional safety standards, such products are intended to help enable customers to design and create their own applications that meet applicable functional safety standards and requirements. Using products in an application does not by itself establish any safety features in the application. Designers must ensure compliance with safety-related requirements and standards applicable to their applications. Designer may not use any TI products in life-critical medical equipment unless authorized officers of the parties have executed a special contract specifically governing such use. Life-critical medical equipment is medical equipment where failure of such equipment would cause serious bodily injury or death (e.g., life support, pacemakers, defibrillators, heart pumps, neurostimulators, and implantables). Such equipment includes, without limitation, all medical devices identified by the U.S. Food and Drug Administration as Class III devices and equivalent classifications outside the U.S.

TI may expressly designate certain products as completing a particular qualification (e.g., Q100, Military Grade, or Enhanced Product). Designers agree that it has the necessary expertise to select the product with the appropriate qualification designation for their applications and that proper product selection is at Designers' own risk. Designers are solely responsible for compliance with all legal and regulatory requirements in connection with such selection.

Designer will fully indemnify TI and its representatives against any damages, costs, losses, and/or liabilities arising out of Designer's non-compliance with the terms and provisions of this Notice.

Looking for pricing, stock, or lifecycle information?

Click below to explore more details on WIN SOURCE:

 [View TPA2100P1YZHT on WIN SOURCE](#)

 [Texas Instruments](#) Information

Optimize Your Supply Chain with WIN SOURCE Solutions

-  Global Sourcing Solution
-  Obsolete Management
-  Cost Control Management
-  Shortage Management
-  Alternative Solution
-  Excess Inventory Management