



**THE DATASHEET OF
SD52-2R2-R**



SD52

High power density, low profile shielded power inductors



Product description

- Octagonal shape shielded drum core
- Inductance range from 1.2 uH to 150 uH
- Current range from 0.28 A to 3.14 A
- 5.6 mm x 5.2 mm footprint surface mount package in a 2.0 mm height
- Ferrite core material
- Halogen free, lead free, RoHS compliant

Applications

- Desktop computers
- Notebook and laptop regulators
- Graphics cards
- Digital cameras, media devices

Environmental Data

- Storage temperature range: -40 °C to +125 °C
- Operating temperature range: -40 °C to +125 °C (ambient plus self-temperature rise).
- Solder reflow temperature: J-STD-020D compliant



Product Specifications

Part Number ⁶	OCL ¹ (µH) ±20%	Part marking	I_{rms}^2 (A)	I_{sat}^3 (A)	DCR ⁴ (Ω) typ.	(V us) typ.
SD52-1R2-R	1.20	A	2.33	3.14	0.0279	1.49
SD52-2R2-R	2.20	B	1.98	2.30	0.0385	2.03
SD52-3R5-R	3.50	C	1.73	1.82	0.0503	2.57
SD52-4R7-R	4.70	D	1.63	1.64	0.0568	2.84
SD52-6R8-R	6.80	E	1.39	1.28	0.0777	3.65
SD52-100-R	10.0	F	1.11	1.11	0.1215	4.19
SD52-150-R	15.0	G	0.97	0.88	0.1618	5.27
SD52-220-R	22.0	H	0.86	0.73	0.2042	6.35
SD52-270-R	27.0	J	0.73	0.65	0.2864	7.16
SD52-330-R	33.0	K	0.70	0.61	0.3074	7.70
SD52-470-R	47.0	L	0.58	0.50	0.4465	9.32
SD52-680-R	68.0	M	0.47	0.42	0.6829	11.21
SD52-101-R	100	N	0.39	0.35	1.0000	13.37
SD52-151-R	150	O	0.31	0.28	1.6100	17.00

- Open Circuit Inductance (OCL) Test Parameters: 100 kHz, 0.25 Vrms, 0.0 Adc.
- Irms: DC current for an approximate ΔT of 40 °C without core loss. De-rating is necessary for AC currents. Temperature rise is dependent upon several factors, including the PCB pad layout, trace thickness and width, air-flow and proximity to other heat generating components. It is recommended the part temperature not exceed 125 °C under worst case operating conditions and therefore, the temperature rise should be verified in the end use application.
- Isat: Peak current for approximately 30% rolloff at +20 °C.
- DCR limits @ 20°C.
- Applied Volt-Time product (V-us) across the inductor at 100 kHz necessary to generate a core loss equal to 10% of the total losses for 40 °C temperature rise.
- Part number definition: SD52-xxx-R
SD52= Product code and size
-xxx=Inductance value in µH, R= decimal point - If no R is present, then last character equals the number of zeros

Dimensions (mm)

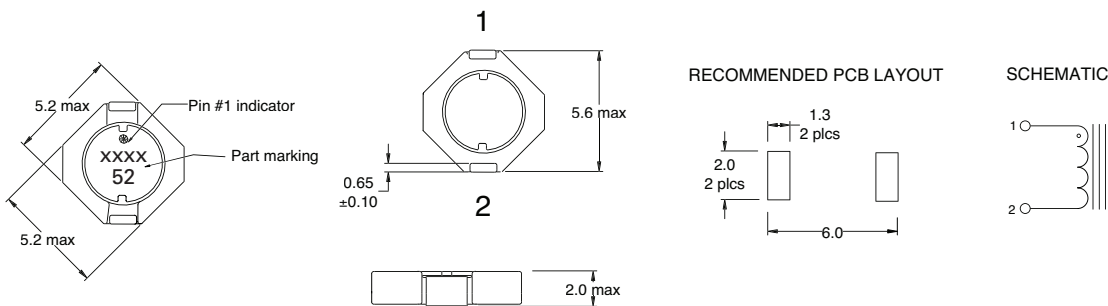

Part Marking: 1st digit= the inductance value per part marking designator, 2nd digit = bi-weekly production date code, 3rd digit = last digit of the year produced, 4th digit= internal manufacturing code.

52 = the product size code.

Do not route traces or vias underneath the inductor.

Packaging information (mm)

Parts packaged on 13" Diameter reel, 3,500 parts per reel.

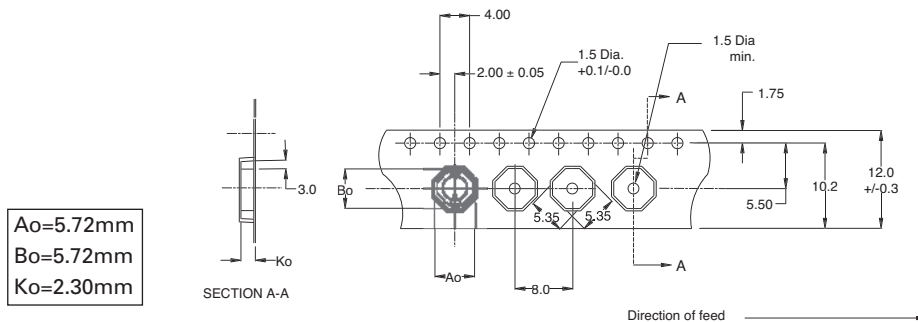

DC current vs. temperature

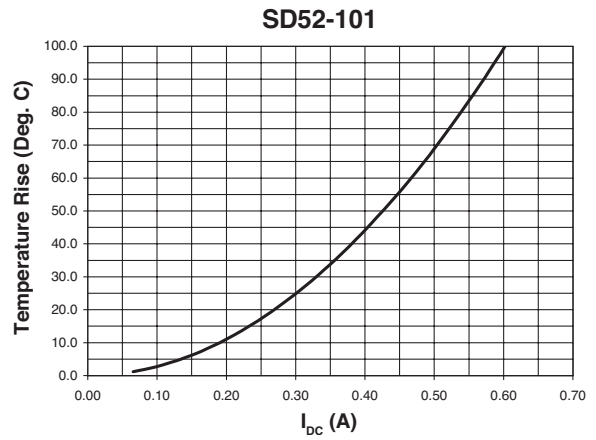
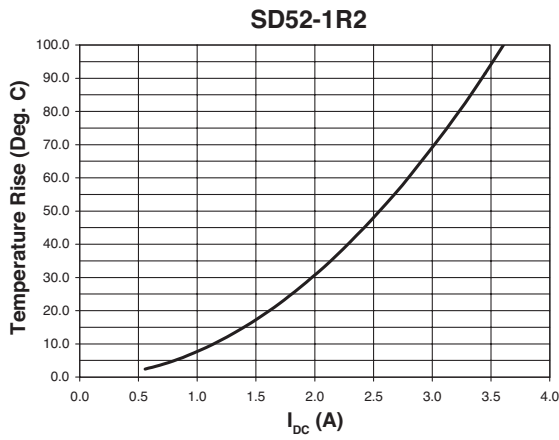

Inductance characteristics

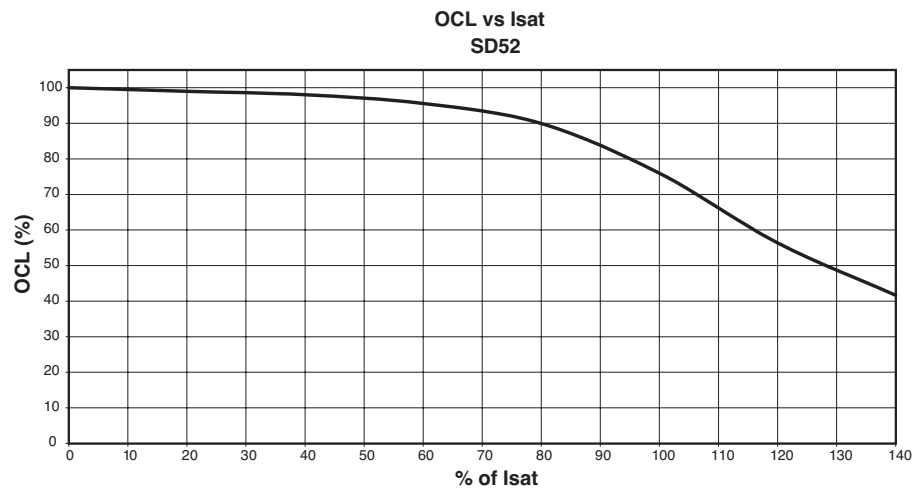

Core loss

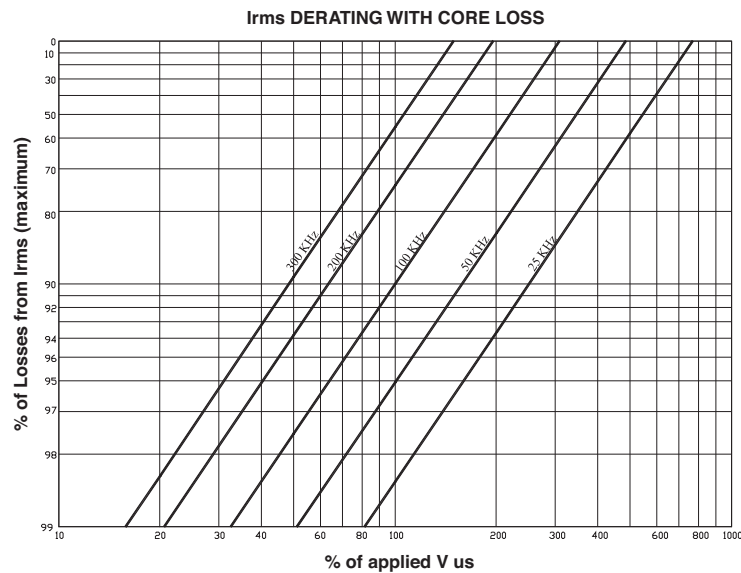

Solder reflow profile

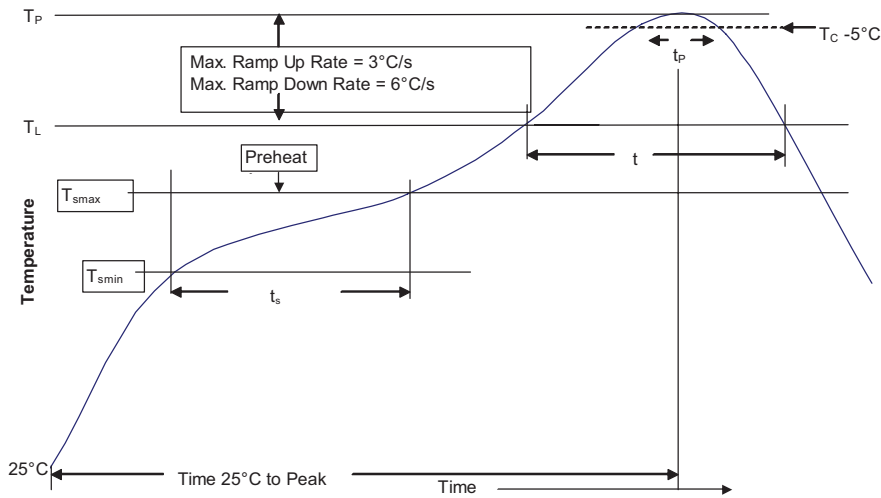

Table 1 - Standard SnPb Solder (T_c)

Package Thickness	Volume mm ³ <350	Volume mm ³ ≥350
<2.5mm)	235°C	220°C
≥2.5mm	220°C	220°C

Table 2 - Lead (Pb) Free Solder (T_c)

Package Thickness	Volume mm ³ <350	Volume mm ³ 350 - 2000	Volume mm ³ >2000
<1.6mm	260°C	260°C	260°C
1.6 - 2.5mm	260°C	250°C	245°C
>2.5mm	250°C	245°C	245°C

Reference JDEC J-STD-020D

Profile Feature	Standard SnPb Solder	Lead (Pb) Free Solder
Preheat and Soak		
• Temperature min. (T_{smin})	100°C	150°C
• Temperature max. (T_{smax})	150°C	200°C
• Time (T_{smin} to T_{smax}) (t_s)	60-120 Seconds	60-120 Seconds
Average ramp up rate T_{smax} to T_p	3°C/ Second Max.	3°C/ Second Max.
Liquidous temperature (T_L)	183°C	217°C
Time at liquidous (t_L)	60-150 Seconds	60-150 Seconds
Peak package body temperature (T_p)*	Table 1	Table 2
Time (t_p)** within 5 °C of the specified classification temperature (T_c)	20 Seconds**	30 Seconds**
Average ramp-down rate (T_p to T_{smax})	6°C/ Second Max.	6°C/ Second Max.
Time 25°C to Peak Temperature	6 Minutes Max.	8 Minutes Max.

* Tolerance for peak profile temperature (T_p) is defined as a supplier minimum and a user maximum.

** Tolerance for time at peak profile temperature (t_p) is defined as a supplier minimum and a user maximum.

Life Support Policy: Eaton does not authorize the use of any of its products for use in life support devices or systems without the express written approval of an officer of the Company. Life support systems are devices which support or sustain life, and whose failure to perform, when properly used in accordance with instructions for use provided in the labeling, can be reasonably expected to result in significant injury to the user.

Eaton reserves the right, without notice, to change design or construction of any products and to discontinue or limit distribution of any products. Eaton also reserves the right to change or update, without notice, any technical information contained in this bulletin.

Eaton
Electronics Division
 1000 Eaton Boulevard
 Cleveland, OH 44122
 United States
 www.eaton.com/elx

© 2015 Eaton
 All Rights Reserved
 Printed in USA
 Publication No. 4311
 November 2015



Eaton is a registered trademark.

All other trademarks are property of their respective owners.

Looking for pricing, stock, or lifecycle information?

Click below to explore more details on WIN SOURCE:

 [View SD52-2R2-R on WIN SOURCE](#)

 [Eaton Bussmann Information](#)

Optimize Your Supply Chain with WIN SOURCE Solutions

-  Global Sourcing Solution
-  Obsolete Management
-  Cost Control Management
-  Shortage Management
-  Alternative Solution
-  Excess Inventory Management