



**THE DATASHEET OF  
TPS61041QDBVRQ1**



## TPS6104x-Q1 Low-Power DC-DC Boost Converter in SOT-23 Package

### 1 Features

- Qualified for Automotive Applications
- 1.8-V to 6-V Input Voltage Range
- Adjustable Output Voltage Range Up to 28 V
- 400-mA (TPS61040-Q1) and 250-mA (TPS61041-Q1) Internal Switch Current
- Up to 1-MHz Switching Frequency
- 28- $\mu$ A Typical No Load Quiescent Current
- 1- $\mu$ A Typical Shutdown Current
- Internal Soft Start
- Space-Saving, 5-Pin SOT-23 Package

### 2 Applications

- Automotive Telematics, eCall, and Tolling
- Infotainment and Clusters
- Advanced Driver Assistance System (ADAS)
- LCD Bias Supplies
- White-LED Supplies for LCD Backlights
- Dual-CELL NiMH/NiCd or Single-CELL Li-Ion Battery-Powered Systems
- Standard 3.3-V or 5-V to 12-V Conversions

### 3 Description

The TPS6104x-Q1 devices are high-frequency boost converters for automotive applications. The devices are ideal for generating output voltages up to 28 V from a pre-regulated low voltage rail, dual-cell NiMH/NiCd or a single-cell Li-Ion battery, supporting input voltages from 1.8 V to 6 V.

The TPS6104x-Q1 devices operate with a switching frequency up to 1 MHz, allowing the use of small external components such as ceramic as well as tantalum output capacitors. Combined with the space-saving, 5-pin SOT-23 package, the TPS6104x-Q1 devices accomplish a small overall solution size. The TPS61040-Q1 device has an internal 400-mA switch current limit, while the TPS61041-Q1 device has a 250-mA switch current limit, offering lower output voltage ripple and allowing the use of a smaller form factor inductor for lower-power applications.

The TPS6104x-Q1 devices operate in a pulse frequency modulation (PFM) scheme with constant peak current control. The combination of low quiescent current (28  $\mu$ A typical) and the optimized control scheme enable operation of the devices at high efficiencies over the entire load current range.

#### Device Information<sup>(1)</sup>

PART NUMBER	PACKAGE	BODY SIZE (NOM)
TPS6104x-Q1	SOT-23 (5)	2.90 mm x 1.60 mm

(1) For all available packages, see the orderable addendum at the end of the data sheet.

#### Typical Application Diagram

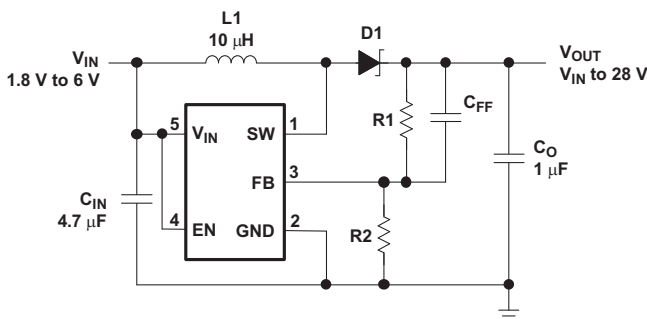

#### Efficiency vs Output Current

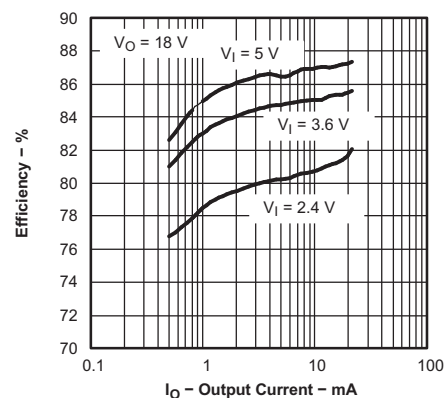

## Table of Contents

<b>1 Features</b> ..... 1 <b>2 Applications</b> ..... 1 <b>3 Description</b> ..... 1 <b>4 Revision History</b> ..... 2 <b>5 Pin Configuration and Functions</b> ..... 3 <b>6 Specifications</b> ..... 4 6.1 Absolute Maximum Ratings ..... 4 6.2 ESD Ratings ..... 4 6.3 Recommended Operating Conditions ..... 4 6.4 Thermal Information ..... 4 6.5 Electrical Characteristics ..... 5 6.6 Typical Characteristics ..... 6 <b>7 Detailed Description</b> ..... 9 7.1 Overview ..... 9 7.2 Functional Block Diagram ..... 9 7.3 Feature Description ..... 9 7.4 Device Functional Modes ..... 10	<b>8 Application and Implementation</b> ..... 11 8.1 Application Information ..... 11 8.2 Typical Application ..... 11 8.3 System Examples ..... 16 <b>9 Power Supply Recommendations</b> ..... 19 <b>10 Layout</b> ..... 19 10.1 Layout Guidelines ..... 19 10.2 Layout Example ..... 19 <b>11 Device and Documentation Support</b> ..... 20 11.1 Device Support ..... 20 11.2 Related Links ..... 20 11.3 Community Resource ..... 20 11.4 Trademarks ..... 20 11.5 Electrostatic Discharge Caution ..... 20 11.6 Glossary ..... 20 <b>12 Mechanical, Packaging, and Orderable Information</b> ..... 20
---	--

## 4 Revision History

NOTE: Page numbers for previous revisions may differ from page numbers in the current version.

Changes from Revision C (April 2012) to Revision D	Page
• Changed bullets in <i>Applications</i> .....	1
• Added <i>ESD Ratings</i> table, <i>Feature Description</i> section, <i>Device Functional Modes</i> , <i>Application and Implementation</i> section, <i>Power Supply Recommendations</i> section, <i>Layout</i> section, <i>Device and Documentation Support</i> section, and <i>Mechanical, Packaging, and Orderable Information</i> section .....	1
• Changed TPS61040/TPS61041 to TPS6104x-Q1, add -Q1 to TPS61040 and TPS61041, VIN and Vin to V <sub>IN</sub> , C <sub>FF</sub> to C <sub>FF</sub> , R <sub>DS(ON)</sub> and R <sub>DSon</sub> to R <sub>DS(on)</sub> , and I <sub>sw</sub> to I <sub>SW</sub> throughout document .....	1
• Updated text in <i>Description</i> .....	1
• Added MAX value of 47 in the Inductor row of <i>Recommended Operating Conditions</i> for better clarity .....	4
• Changed Operating junction temperature row to Operating ambient temperature row in <i>Recommended Operating Conditions</i> .....	4
• Changed T <sub>J</sub> to T <sub>A</sub> in the conditions statement of <i>Electrical Characteristics</i> .....	5
• Moved figures 12 through 14 to <i>Application Curves</i> section .....	6
• Deleted 50 mA from <i>Inductor Selection, Maximum Load Current</i> .....	11
• Deleted Sumida CR32-100 row from <a href="#">Table 3</a> .....	13
• Changed Layout Diagram in <i>Layout Example</i> .....	19

Changes from Revision B (July 2011) to Revision C	Page
• Added THERMAL SHUTDOWN section between UNDERVOLTAGE LOCKOUT and ABS MAX Table. ....	10

## 5 Pin Configuration and Functions

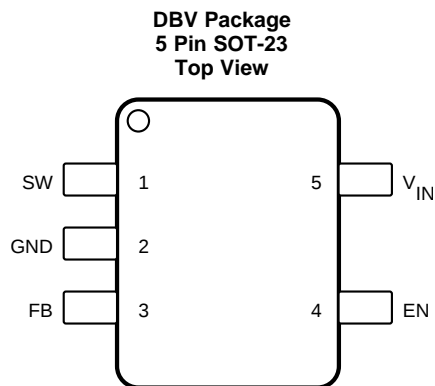

### Pin Functions

PIN		I/O	DESCRIPTION
NAME	NO.		
EN	4	I	This is the enable pin of the device. Pulling this pin to ground forces the device into shutdown mode reducing the supply current to less than 1 $\mu$ A. This pin must not be left floating and must be terminated.
FB	3	I	This is the feedback pin of the device. Connect this pin to the external voltage divider to program the desired output voltage.
GND	2	—	Ground
SW	1	I	Connect the inductor and the Schottky diode to this pin. This is the switch pin and is connected to the drain of the internal power MOSFET.
V <sub>IN</sub>	5	I	Supply voltage pin

## 6 Specifications

### 6.1 Absolute Maximum Ratings

over operating free-air temperature range (unless otherwise noted)<sup>(1)</sup>

	MIN	MAX	UNIT
Supply voltages on pin $V_{IN}$ <sup>(2)</sup>	-0.3	7	V
Voltages on pins EN, FB <sup>(2)</sup>	-0.3	$V_{IN} + 0.3$	V
Switch voltage on pin SW <sup>(2)</sup>		30	V
Continuous power dissipation	See <a href="#">Thermal Information</a>		
$T_J$ Operating junction temperature	-40	150	°C
$T_{Stg}$ Storage temperature	-65	150	°C

- (1) Stresses beyond those listed under *Absolute Maximum Ratings* may cause permanent damage to the device. These are stress ratings only, which do not imply functional operation of the device at these or any other conditions beyond those indicated under *Recommended Operating Conditions*. Exposure to absolute-maximum-rated conditions for extended periods may affect device reliability.
- (2) All voltage values are with respect to network ground terminal.

### 6.2 ESD Ratings

		VALUE	UNIT
$V_{ESD}$ Electrostatic discharge	Human-body model (HBM), per AEC Q100-002 <sup>(1)</sup>	±2000	V
	Charged-device model (CDM), per AEC Q100-011	±750	

- (1) AEC Q100-002 indicates that HBM stressing shall be in accordance with the ANSI/ESDA/JEDEC JS-001 specification.

### 6.3 Recommended Operating Conditions

		MIN	TYP	MAX	UNIT
$V_{IN}$ Input voltage		1.8		6	V
$V_{OUT}$ Output voltage				28	V
L Inductor <sup>(1)</sup>		2.2	10	47	μH
f Switching frequency <sup>(1)</sup>				1	MHz
$C_{IN}$ Input capacitor <sup>(1)</sup>			4.7		μF
$C_{OUT}$ Output capacitor <sup>(1)</sup>		1			μF
$T_A$ Operating ambient temperature		-40		125	°C

- (1) See [Application and Implementation](#) section for further information.

### 6.4 Thermal Information

THERMAL METRIC <sup>(1)</sup>		TPS6104x-Q1	UNIT
		DBV (SOT-23)	
		5 PINS	
$R_{\theta JA}$ Junction-to-ambient thermal resistance		153.5	°C/W
$R_{\theta JC(top)}$ Junction-to-case (top) thermal resistance		105.7	°C/W
$R_{\theta JB}$ Junction-to-board thermal resistance		33.5	°C/W
$\Psi_{JT}$ Junction-to-top characterization parameter		9.8	°C/W
$\Psi_{JB}$ Junction-to-board characterization parameter		33.1	°C/W

- (1) For more information about traditional and new thermal metrics, see the *Semiconductor and IC Package Thermal Metrics* application report, [SPRA953](#).

## 6.5 Electrical Characteristics

 $V_{IN} = 2.4\text{ V}$ ,  $EN = V_{IN}$ ,  $T_A = -40^\circ\text{C}$  to  $125^\circ\text{C}$ , typical values are at  $T_A = 25^\circ\text{C}$  (unless otherwise noted)

PARAMETER		TEST CONDITIONS	MIN	TYP	MAX	UNIT	
<b>SUPPLY CURRENT</b>							
$V_{IN}$	Input voltage range		1.8		6	V	
$I_Q$	Operating quiescent current	$I_{OUT} = 0\text{ mA}$ , not switching, $V_{FB} = 1.3\text{ V}$		28	50	$\mu\text{A}$	
$I_{SD}$	Shutdown current	$EN = \text{GND}$		0.1	1	$\mu\text{A}$	
$V_{UVLO}$	Undervoltage lockout threshold			1.5	1.7	V	
<b>ENABLE</b>							
$V_{IH}$	EN high level input voltage		1.3			V	
$V_{IL}$	EN low level input voltage				0.4	V	
$I_I$	EN input leakage current	$EN = \text{GND}$ or $V_{IN}$		0.1	1	$\mu\text{A}$	
<b>POWER SWITCH AND CURRENT LIMIT</b>							
$V_{sw}$	Maximum switch voltage				30	V	
$t_{off}$	Minimum OFF time		250	400	550	ns	
$t_{on}$	Maximum ON time		4	6	7.5	$\mu\text{s}$	
$R_{DS(on)}$	MOSFET ON-resistance	$V_{IN} = 2.4\text{ V}$ ; $I_{SW} = 200\text{ mA}$ ; TPS61040-Q1		600	1100	$\text{m}\Omega$	
$R_{DS(on)}$	MOSFET ON-resistance	$V_{IN} = 2.4\text{ V}$ ; $I_{SW} = 200\text{ mA}$ ; TPS61041-Q1		750	1300	$\text{m}\Omega$	
	MOSFET leakage current	$V_{SW} = 28\text{ V}$		1	10	$\mu\text{A}$	
$I_{LIM}$	MOSFET current limit	TPS61040-Q1	325	400	500	mA	
$I_{LIM}$	MOSFET current limit	TPS61041-Q1	200	250	325	mA	
<b>OUTPUT</b>							
$V_{OUT}$	Adjustable output voltage range <sup>(1)</sup>		$V_{IN}$		28	V	
$V_{ref}$	Internal voltage reference			1.233		V	
$I_{FB}$	Feedback input bias current	$V_{FB} = 1.3\text{ V}$			1	$\mu\text{A}$	
$V_{FB}$	Feedback trip point voltage	$1.8\text{ V} \leq V_{IN} \leq 6\text{ V}$	$T_J = -40^\circ\text{C}$ to $85^\circ\text{C}$	1.208	1.233	1.258	V
			$T_J = -40^\circ\text{C}$ to $125^\circ\text{C}$	1.2	1.233	1.27	
	Line regulation <sup>(2)</sup>	$1.8\text{ V} \leq V_{IN} \leq 6\text{ V}$ ; $V_{OUT} = 18\text{ V}$ ; $I_{load} = 10\text{ mA}$ ; $C_{FF} = \text{not connected}$		0.05		%/V	
	Load regulation <sup>(2)</sup>	$V_{IN} = 2.4\text{ V}$ ; $V_{OUT} = 18\text{ V}$ ; $0\text{ mA} \leq I_{OUT} \leq 30\text{ mA}$		0.15		%/mA	

(1) Cannot be production tested. Assured by design.

(2) The line and load regulation depend on the external component selection. See [Application and Implementation](#) for further information.

## 6.6 Typical Characteristics

Table 1. Table of Graphs

		FIGURE	
$\eta$	Efficiency	vs Load current	Figure 1, Figure 2, Figure 3
		vs Input voltage	Figure 4
$I_Q$	Quiescent current	vs Input voltage and temperature	Figure 5
$V_{FB}$	Feedback voltage	vs Temperature	Figure 6
$I_{SW}$	Switch current limit	vs Temperature	Figure 7
$I_{CL}$	Switch current limit	vs Supply voltage, TPS61041-Q1	Figure 8
		vs Supply voltage, TPS61040-Q1	Figure 9
$R_{DS(on)}$	$R_{DS(on)}$	vs Temperature	Figure 10
		vs Supply voltage	Figure 11
	Line transient response		Figure 13
	Load transient response		Figure 14
	Start-up behavior		Figure 15

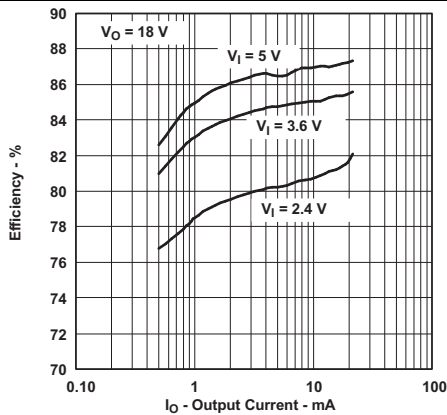

Figure 1. Efficiency vs Output Current

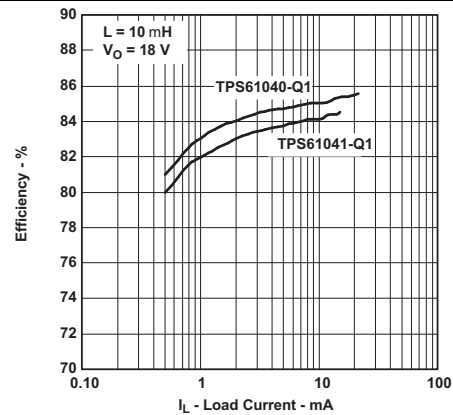

Figure 2. Efficiency vs Load Current

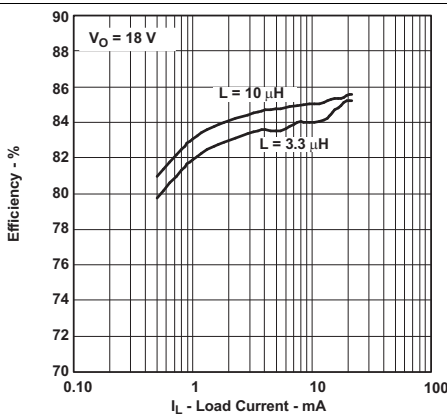

Figure 3. Efficiency vs Load Current

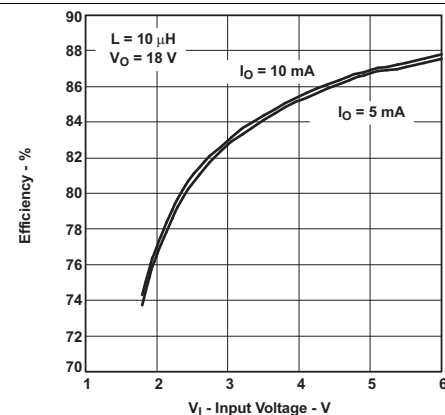

Figure 4. Efficiency vs Input Voltage

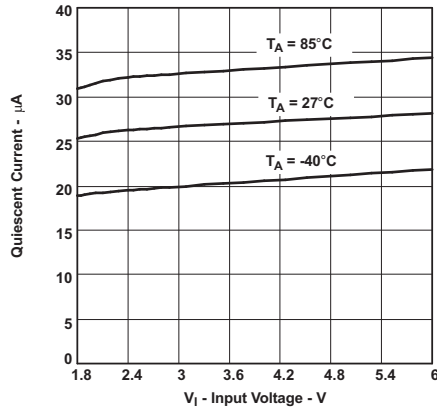

Figure 5. TPS61040-Q1 Quiescent Current vs Input Voltage

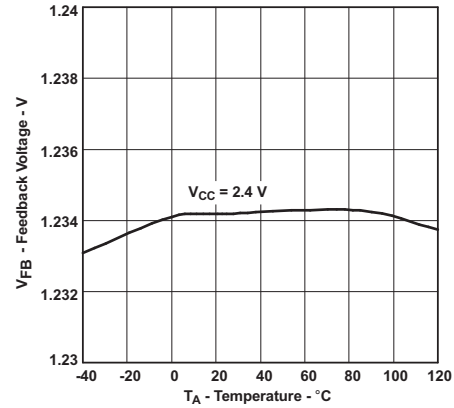

Figure 6. Feedback Voltage vs Free-Air Temperature

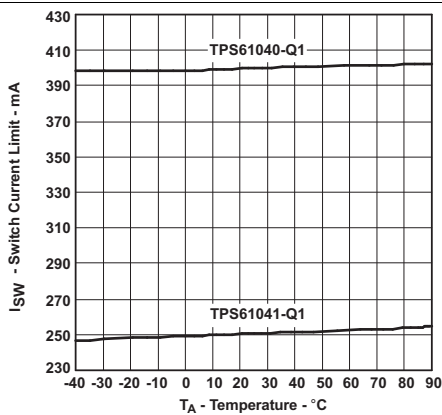

Figure 7. TPS6104x-Q1 Switch Current Limit vs Free-Air Temperature

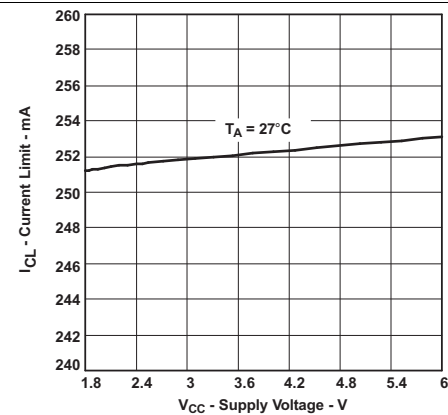

Figure 8. TPS61041-Q1 Current Limit vs Supply Voltage

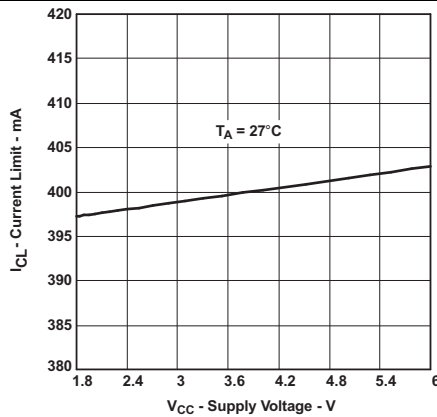

Figure 9. TPS61040-Q1 Current Limit vs Supply Voltage

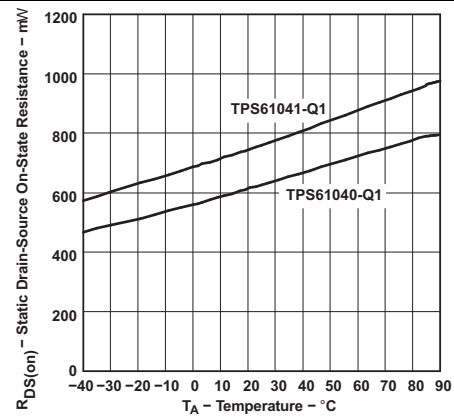
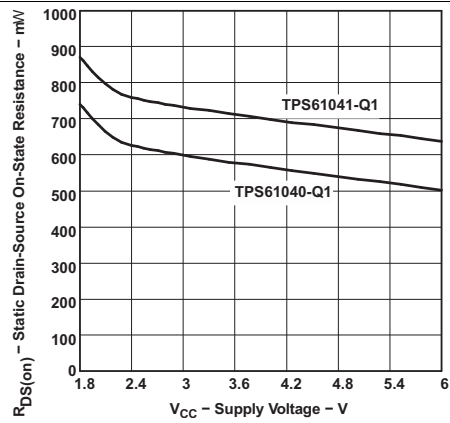

Figure 10. TPS6104x-Q1 Static Drain-Source ON-State Resistance vs Free-Air Temperature



**Figure 11. TPS6104x-Q1 Static Drain-Source ON-State Resistance vs Supply Voltage**

## 7 Detailed Description

### 7.1 Overview

The TPS6104x-Q1 is a high-frequency boost converter dedicated for small-to-medium LCD bias supply and white-LED backlight supplies. The device is ideal for generating output voltages up to 28 V from a dual-cell NiMH/NiCd or a single-cell device Li-Ion battery.

### 7.2 Functional Block Diagram

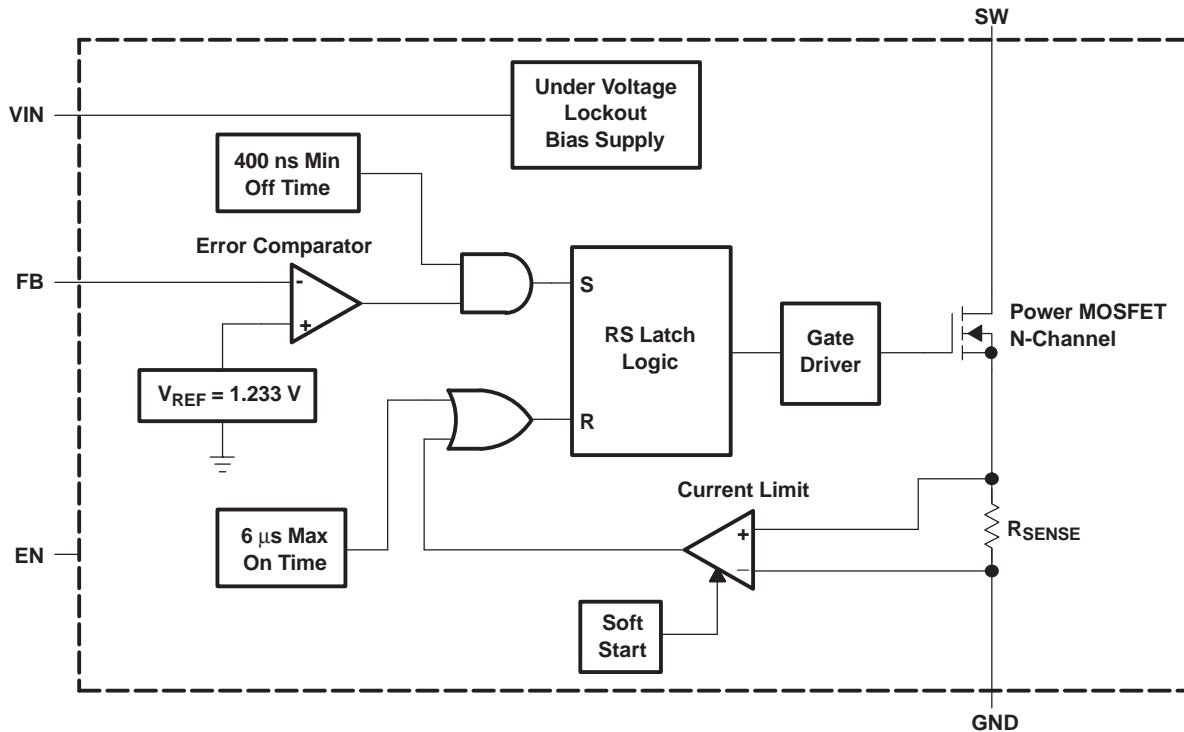

### 7.3 Feature Description

#### 7.3.1 Peak Current Control

The internal switch turns on until the inductor current reaches the typical DC current limit ( $I_{LIM}$ ) of 400 mA (TPS61040-Q1) or 250 mA (TPS61041-Q1). Due to the internal propagation delay of typical 100 ns, the actual current exceeds the DC-current limit threshold by a small amount. The typical peak current limit can be calculated:

$$I_{peak(typ)} = I_{LIM} + \frac{V_{IN}}{L} \times 100 \text{ ns}$$

$$I_{peak(typ)} = 400 \text{ mA} + \frac{V_{IN}}{L} \times 100 \text{ ns} \text{ for the TPS61040-Q1}$$

$$I_{peak(typ)} = 250 \text{ mA} + \frac{V_{IN}}{L} \times 100 \text{ ns} \text{ for the TPS61041-Q1}$$

where

- $V_{IN}$  = Input voltage
- $L$  = Selected inductor value
- $I_{LIM}$  = Typical DC current limit

(1)

The higher the input voltage and the lower the inductor value, the greater the peak.

## Feature Description (continued)

By selecting the TPS6104x-Q1, it is possible to tailor the design to the specific application current limit requirements. A lower current limit supports applications requiring lower output power and allows the use of an inductor with a lower current rating and a smaller form factor. A lower current limit usually has a lower output-voltage ripple as well.

### 7.3.2 Soft Start

All inductive step-up converters exhibit high inrush current during start-up if no special precaution is made. This can cause voltage drops at the input rail during start-up and may result in an unwanted or early system shutdown.

The TPS6104x-Q1 limits this inrush current by increasing the current limit in two steps starting from  $\frac{I_{LIM}}{4}$  for 256 cycles to  $\frac{I_{LIM}}{2}$  for the next 256 cycles, and then full current limit (see [Figure 15](#)).

### 7.3.3 Enable

Pulling the enable (EN) to ground shuts down the device reducing the shutdown current to 1  $\mu$ A (typical). Because there is a conductive path from the input to the output through the inductor and Schottky diode, the output voltage is equal to the input voltage during shutdown. The enable pin must be terminated and must not be left floating. Using a small external transistor disconnects the input from the output during shutdown as shown in [Figure 17](#).

### 7.3.4 Undervoltage Lockout

An undervoltage lockout prevents misoperation of the device at input voltages below typical 1.5 V. When the input voltage is below the undervoltage threshold the main switch is turned off.

### 7.3.5 Thermal Shutdown

An internal thermal shutdown is implemented and turns off the internal MOSFETs when the typical junction temperature of 168°C is exceeded. The thermal shutdown has a hysteresis of typically 25°C. This data is based on statistical means and is not tested during the regular mass production of the IC.

## 7.4 Device Functional Modes

The TPS6104x-Q1 operates with an input voltage range of 1.8 V to 6 V and can generate output voltages up to 28 V. The device operates in a pulse frequency modulation (PFM) scheme with constant peak current control. This control scheme maintains high efficiency over the entire load current range, and with a switching frequency up to 1 MHz, the device enables the use of very small external components.

The converter monitors the output voltage, and as soon as the feedback voltage falls below the reference voltage of typically 1.233 V, the internal switch turns on and the current ramps up. The switch turns off as soon as the inductor current reaches the internally set peak current of typically 400 mA (TPS61040-Q1) or 250 mA (TPS61041-Q1). See [Peak Current Control](#) for more information. The second criteria that turns off the switch is the maximum ON-time of 6  $\mu$ s (typical). This is just to limit the maximum ON-time of the converter to cover for extreme conditions. As the switch is turned off, the external Schottky diode is forward biased delivering the current to the output. The switch remains off for a minimum of 400 ns (typical), or until the feedback voltage drops below the reference voltage again. Using this PFM peak-current control scheme, the converter operates in discontinuous conduction mode (DCM) where the switching frequency depends on the output current, which results in high efficiency over the entire load current range. This regulation scheme is inherently stable, allowing a wider selection range for the inductor and output capacitor.

## 8 Application and Implementation

### NOTE

Information in the following applications sections is not part of the TI component specification, and TI does not warrant its accuracy or completeness. TI's customers are responsible for determining suitability of components for their purposes. Customers should validate and test their design implementation to confirm system functionality.

### 8.1 Application Information

The TPS6104x-Q1 is designed for output voltages up to 28 V with an input voltage range of 1.8 V to 6 V. TPS61040-Q1 can operate up to 400-mA typical peak load current and TPS61041-Q1 can operate up to 250-mA typical peak load current. The device operates in a pulse-frequency-modulation (PFM) scheme with constant peak-current control. This control scheme maintains high efficiency over the entire load current range, and with a switching frequency up to 1 MHz, the device enables the use of very small external components.

### 8.2 Typical Application

The following section provides a step-by-step design approach for configuring the TPS61040-Q1 as a voltage-regulating boost converter for LCD bias supply, as shown in Figure 12.

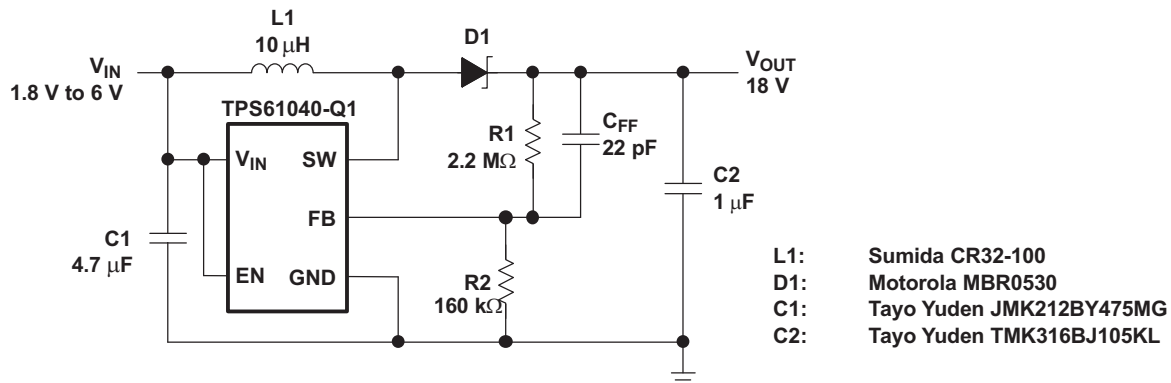

Figure 12. LCD Bias Supply

#### 8.2.1 Design Requirements

Table 2 lists the design parameters for this example.

Table 2. Design Parameters

DESIGN PARAMETER	EXAMPLE VALUE
Input Voltage	1.8 V to 6 V
Output Voltage	18 V
Output Current	10 mA

#### 8.2.2 Detailed Design Procedure

##### 8.2.2.1 Inductor Selection, Maximum Load Current

Because the PFM peak-current control scheme is inherently stable, the inductor value does not affect the stability of the regulator. The selection of the inductor together with the nominal load current, input and output voltage of the application determines the switching frequency of the converter. Depending on the application, TI recommends inductor values from 2.2  $\mu$ H to 47  $\mu$ H. The maximum inductor value is determined by the maximum ON-time of the switch, typically 6  $\mu$ s. The peak current limit of 400 mA (typically) must be reached within this 6- $\mu$ s period for proper operation.

The inductor value determines the maximum switching frequency of the converter. Therefore, select the inductor value that ensures the maximum switching frequency at the converter maximum load current is not exceeded. The maximum switching frequency is calculated using [Equation 2](#).

$$f_{S(\max)} = \frac{V_{IN(\min)} \times (V_{OUT} - V_{IN})}{I_P \times L \times V_{OUT}}$$

Where:

- $I_P$  = Peak current as described in [Peak Current Control](#)
- $L$  = Selected inductor value
- $V_{IN(\min)}$  = The highest switching frequency occurs at the minimum input voltage

(2)

If the selected inductor value does not exceed the maximum switching frequency of the converter, the next step is to calculate the switching frequency at the nominal load current using [Equation 3](#):

$$f_S(I_{\text{load}}) = \frac{2 \times I_{\text{load}} \times (V_{OUT} - V_{IN} + V_d)}{I_P^2 \times L}$$

Where:

- $I_P$  = Peak current as described in [Peak Current Control](#)
- $L$  = Selected inductor value
- $I_{\text{load}}$  = Nominal load current
- $V_d$  = Rectifier diode forward voltage (typically 0.3 V)

(3)

A smaller inductor value gives a higher converter switching frequency, but lowers the efficiency.

The inductor value has less effect on the maximum available load current and is only of secondary order. The best way to calculate the maximum available load current under certain operating conditions is to estimate the expected converter efficiency at the maximum load current. This number can be taken out of the efficiency graphs shown in [Figure 1](#), [Figure 2](#), [Figure 3](#), and [Figure 4](#). The maximum load current can then be estimated using [Equation 4](#).

$$I_{\text{load}(\max)} = \eta \frac{I_P^2 \times L \times f_{S(\max)}}{2 \times (V_{OUT} - V_{IN})}$$

Where:

- $I_P$  = Peak current as described in [Peak Current Control](#)
- $L$  = Selected inductor value
- $f_{S(\max)}$  = Maximum switching frequency as calculated previously
- $\eta$  = Expected converter efficiency. Typically 70% to 85%.

(4)

The maximum load current of the converter is the current at the operation point where the converter starts to enter the continuous conduction mode. Usually the converter should always operate in discontinuous conduction mode.

Last, the selected inductor must have a saturation current that exceeds the maximum peak current of the converter (as calculated in [Peak Current Control](#)). Use the maximum value for  $I_{LIM}$  for this calculation.

Another important inductor parameter is the DC resistance. The lower the DC resistance, the higher the efficiency of the converter. [Table 3](#) lists few typical inductors for LCD Bias Supply design (see [Figure 12](#)), but customers must verify and validate them to check whether they are suitable for their application.

**Table 3. Typical Inductors for LCD Bias Supply (see [Figure 12](#))**

DEVICE	INDUCTOR VALUE	COMPONENT SUPPLIER	COMMENTS
TPS61040-Q1	10 $\mu$ H	Sumida CDRH3D16-100	High efficiency
	10 $\mu$ H	Murata LQH4C100K04	High efficiency
	4.7 $\mu$ H	Sumida CDRH3D16-4R7	Small solution size
	4.7 $\mu$ H	Murata LQH3C4R7M24	Small solution size
TPS61041-Q1	10 $\mu$ H	Murata LQH3C100K24	High efficiency Small solution size

### 8.2.2.2 Setting The Output Voltage and Feed-Forward Capacitor

The output voltage is calculated as:

$$V_{\text{out}} = 1.233 \text{ V} \times \left( 1 + \frac{R_1}{R_2} \right) \quad (5)$$

For battery-powered applications, a high impedance voltage divider must be used with a typical value for R2 of  $\leq 200 \text{ k}\Omega$  and a maximum value for R1 of 2.2 M $\Omega$ . Smaller values can be used to reduce the noise sensitivity of the feedback pin.

A feed-forward capacitor across the upper feedback resistor R1 is required to provide sufficient overdrive for the error comparator. Without a feed-forward capacitor, or one whose value is too small, the TPS6104x-Q1 shows *double pulses* or a pulse burst instead of single pulses at the switch node (SW), causing higher output voltage ripple. If this higher output voltage ripple is acceptable, the feed-forward capacitor can be left out.

The lower the switching frequency of the converter, the larger the feed-forward capacitor value required. A good starting point is to use a 10-pF feed-forward capacitor. As a first estimation, the required value for the feed-forward capacitor at the operation point can also be calculated using [Equation 6](#).

$$C_{\text{FF}} = \frac{1}{2 \times \pi \times \frac{f_{\text{S}}}{20} \times R_1}$$

Where:

- R1 = Upper resistor of voltage divider
- $f_{\text{S}}$  = Switching frequency of the converter at the nominal load current (see [Inductor Selection, Maximum Load Current](#) for calculating the switching frequency)
- $C_{\text{FF}}$  = Choose a value that comes closest to the result of the calculation (6)

The larger the feed-forward capacitor the worse the line regulation of the device. Therefore, when concern for line regulation is paramount, the selected feed-forward capacitor must be as small as possible. See the next section for more information about line and load regulation.

### 8.2.2.3 Line and Load Regulation

The line regulation of the TPS6104x-Q1 depends on the voltage ripple on the feedback pin. Usually a 50-mV peak-to-peak voltage ripple on the feedback pin FB gives good results.

Some applications require a very tight line regulation and can only allow a small change in output voltage over a certain input voltage range. If no feed-forward capacitor  $C_{\text{FF}}$  is used across the upper resistor of the voltage feedback divider, the device has the best line regulation. Without the feed-forward capacitor the output voltage ripple is higher because the TPS6104x-Q1 shows output voltage bursts instead of single pulses on the switch pin (SW), increasing the output voltage ripple. Increasing the output capacitor value reduces the output voltage ripple.

If a larger output capacitor value is not an option, a feed-forward capacitor  $C_{\text{FF}}$  can be used as described in the previous section. The use of a feed-forward capacitor increases the amount of voltage ripple present on the feedback pin (FB). The greater the voltage ripple on the feedback pin ( $\geq 50 \text{ mV}$ ), the worse the line regulation. There are two ways to improve the line regulation further:

1. Use a smaller inductor value to increase the switching frequency which will lower the output voltage ripple, as well as the voltage ripple on the feedback pin.
2. Add a small capacitor from the feedback pin (FB) to ground to reduce the voltage ripple on the feedback pin down to 50 mV again. As a starting point, the same capacitor value as selected for the feed-forward

capacitor  $C_{FF}$  can be used.

### 8.2.2.4 Output Capacitor Selection

For best output voltage filtering, TI recommends a low ESR output capacitor. Ceramic capacitors have a low ESR value but tantalum capacitors can be used as well, depending on the application.

Assuming the converter does not show double pulses or pulse bursts on the switch node (SW), the output voltage ripple can be calculated using Equation 7.

$$\Delta V_{out} = \frac{I_{out}}{C_{out}} \times \left( \frac{1}{f_S(I_{out})} - \frac{I_P \times L}{V_{out} + V_d - V_{in}} \right) + I_P \times ESR$$

Where:

- $I_P$  = Peak current as described in the [Peak Current Control](#) section
- $L$  = Selected inductor value
- $I_{out}$  = Nominal load current
- $f_S(I_{out})$  = Switching frequency at the nominal load current as calculated previously
- $V_d$  = Rectifier diode forward voltage (typically 0.3 V)
- $C_{out}$  = Selected output capacitor
- ESR = Output capacitor ESR value

(7)

Table 4 lists few typical capacitors for LCD Bias Supply design (see Figure 12), but customers must verify and validate them to check whether they are suitable for their application.

**Table 4. Typical Input and Output Capacitors for LCD Bias Supply Design (See Figure 12)**

DEVICE	CAPACITOR	VOLTAGE RATING	COMPONENT SUPPLIER	COMMENTS
TPS6104x-Q1	4.7 $\mu$ F/X5R/0805	6.3 V	Taiyo Yuden JMK212BY475MG	$C_{IN}$
	10 $\mu$ F/X5R/0805	6.3 V	Taiyo Yuden JMK212BJ106MG	$C_{IN}$
	1 $\mu$ F/X7R/1206	25 V	Taiyo Yuden TMK316BJ105KL	$C_{OUT}$
	1 $\mu$ F/X5R/1206	35 V	Taiyo Yuden GMK316BJ105KL	$C_{OUT}$
	4.7 $\mu$ F/X5R/1210	25 V	Taiyo Yuden TMK325BJ475MG	$C_{OUT}$

### 8.2.2.5 Input Capacitor Selection

For good input voltage filtering, TI recommends low-ESR ceramic capacitors. A 4.7- $\mu$ F ceramic input capacitor is sufficient for most of the applications. For better input voltage filtering this value can be increased. See Table 4 and the [Typical Application](#) section for input capacitor recommendations.

### 8.2.2.6 Diode Selection

To achieve high efficiency, a Schottky diode must be used. The current rating of the diode must meet the peak current rating of the converter as it is calculated in the section peak current control. Use the maximum value for  $I_{LIM}$  for this calculation. Table 5 lists the few typical Schottky Diodes for LCD Bias Supply design shown in Figure 12. Customers must verify and validate them, however, to check whether they are suitable for their application.

**Table 5. Typical Schottky Diodes for LCD Bias Supply Design (See Figure 12)**

DEVICE	REVERSE VOLTAGE	COMPONENT SUPPLIER	COMMENTS
TPS6104x-Q1	30 V	ON Semiconductor MBR0530	
	20 V	ON Semiconductor MBR0520	
	20 V	ON Semiconductor MBRM120L	High efficiency
	30 V	Toshiba CRS02	

**8.2.3 Application Curves**

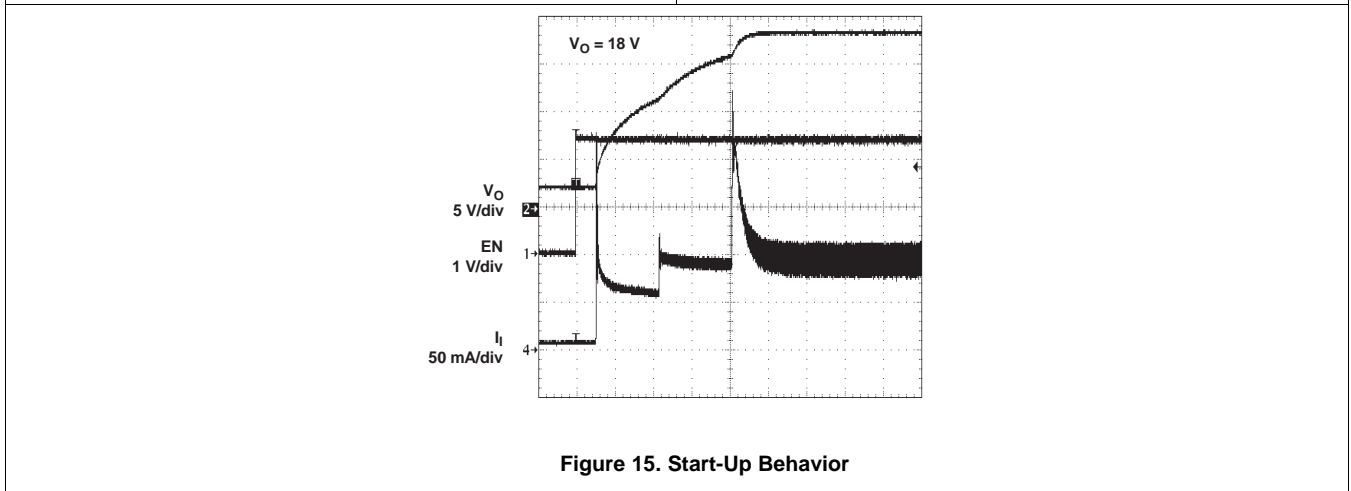
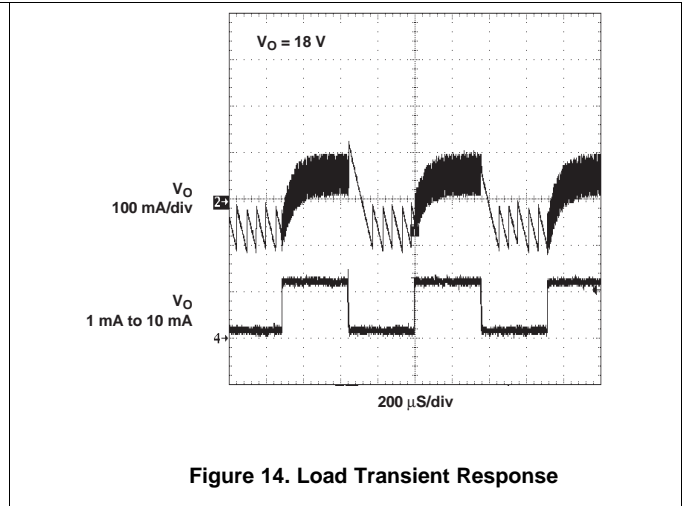
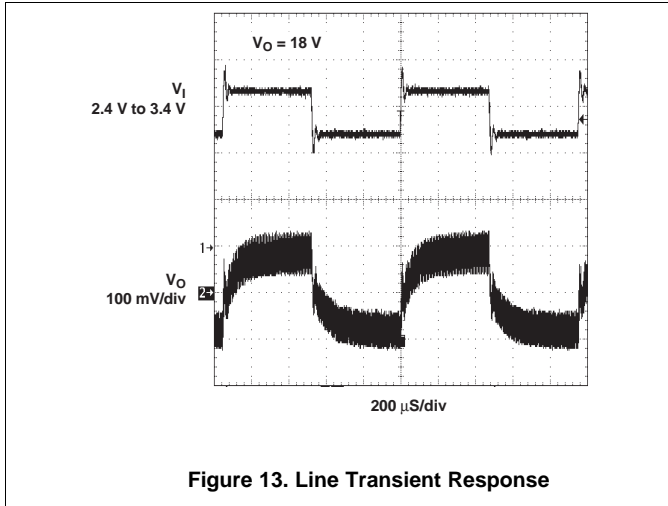

### 8.3 System Examples

Figure 16 to Figure 22 shows the different possible power supply designs with the TPS6104x-Q1 devices. However, these circuits must be fully validated and tested by customers before they actually use them in their designs. TI does not warrant the accuracy or completeness of these circuits, nor does TI accept any responsibility for them.

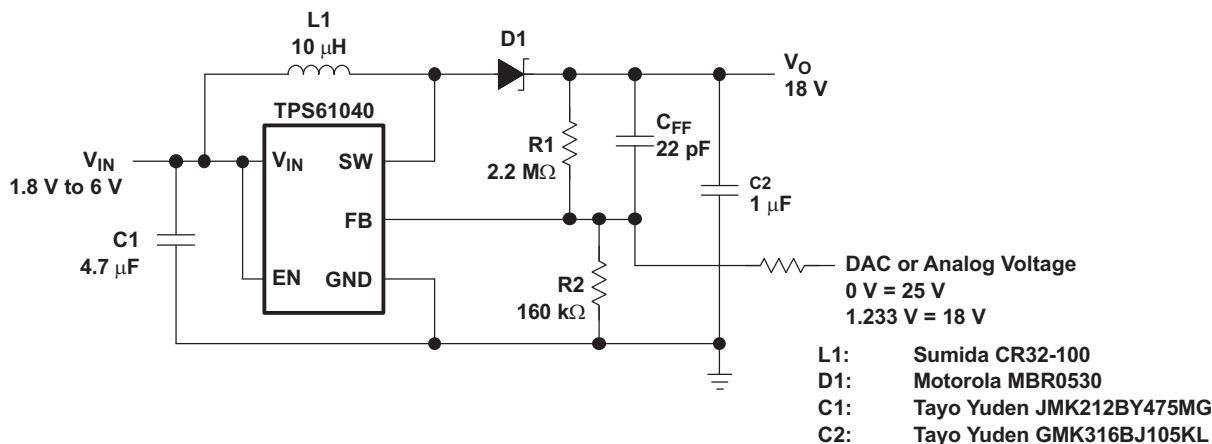

Figure 16. LCD Bias Supply With Adjustable Output Voltage

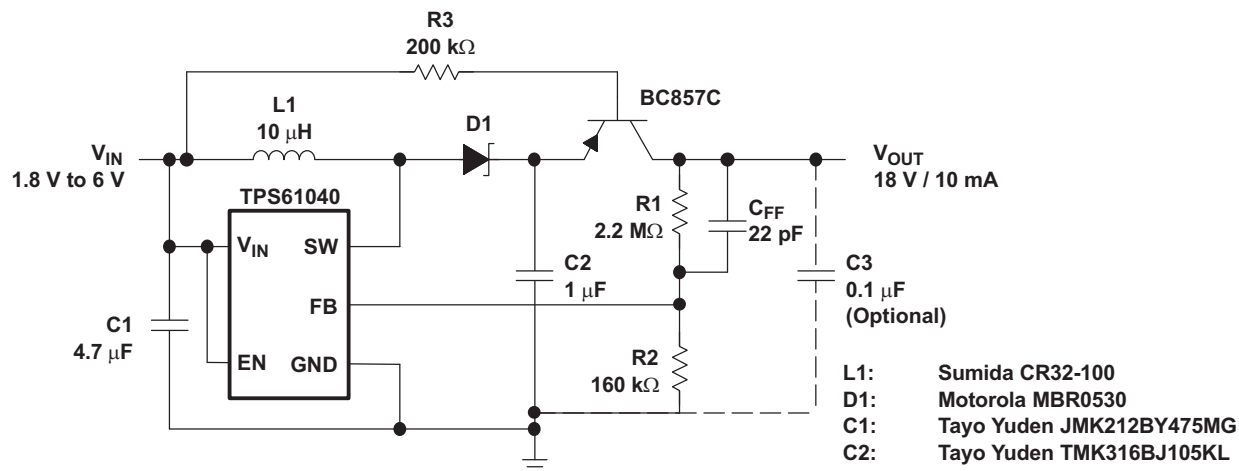

Figure 17. LCD Bias Supply With Load Disconnect

System Examples (continued)

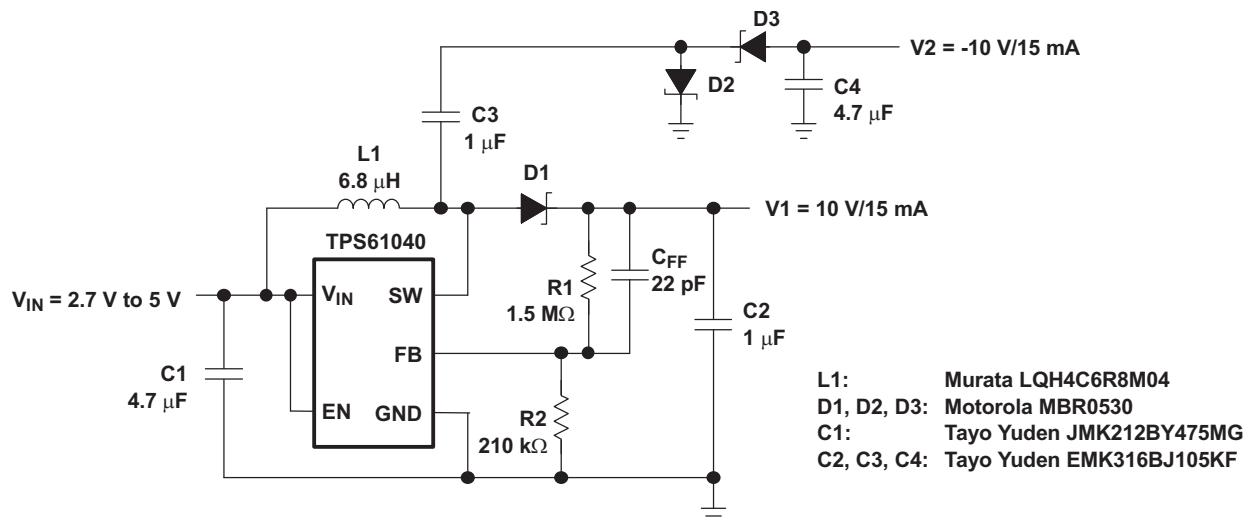

Figure 18. Positive and Negative Output LCD Bias Supply

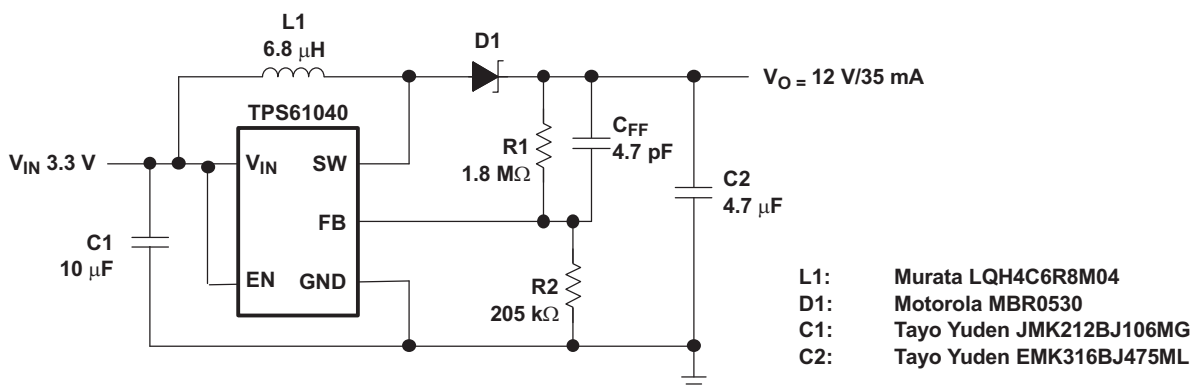

Figure 19. Standard 3.3-V to 12-V Supply

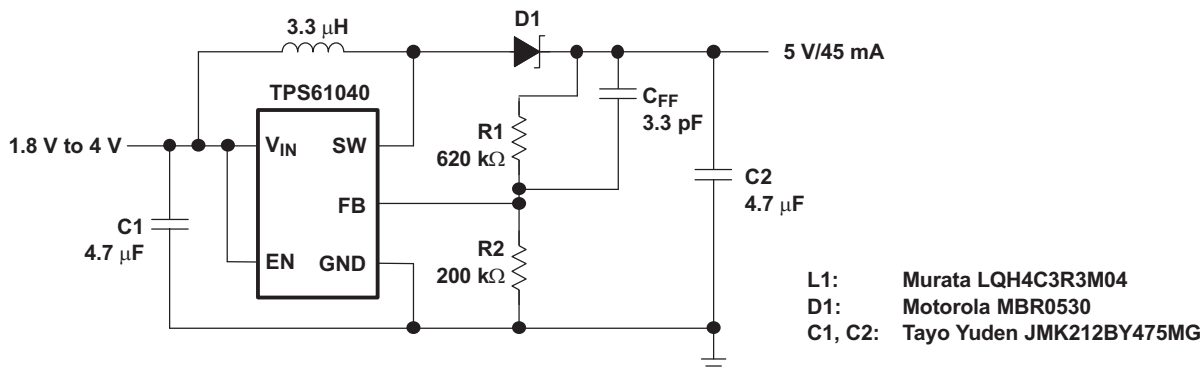
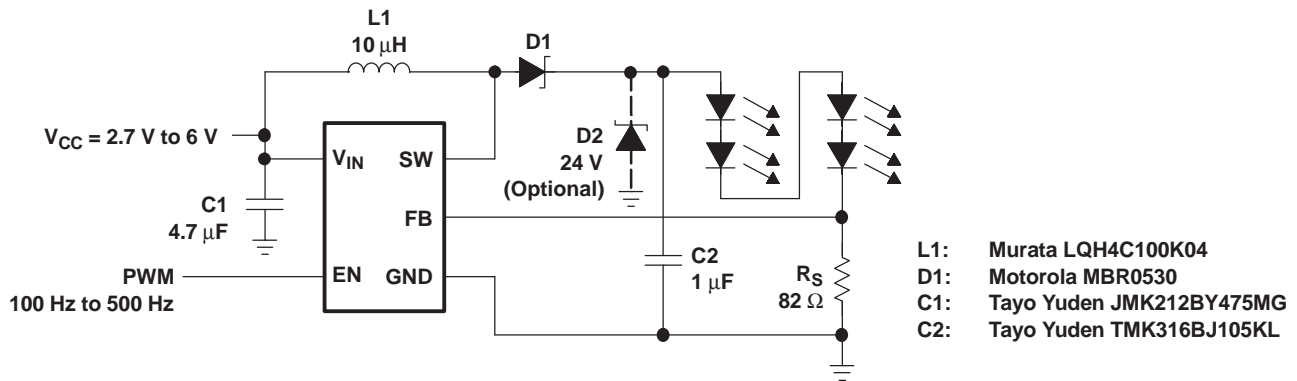
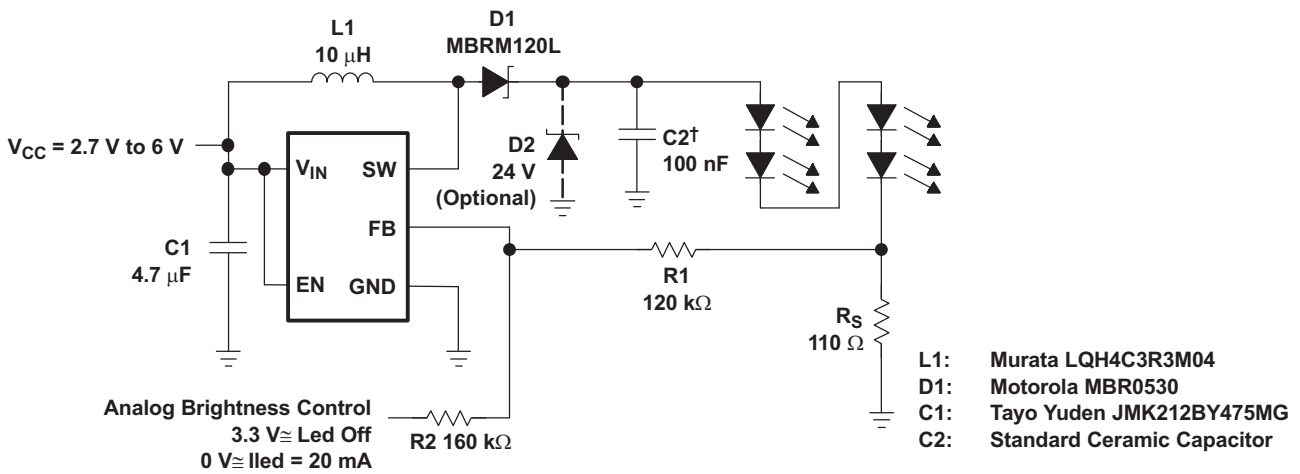

Figure 20. Dual Battery Cell to 5-V/50-mA Conversion  
 Efficiency Approximately Equals 84% at  $V_{IN} = 2.4\text{ V}$  to  $V_O = 5\text{ V}/45\text{ mA}$

System Examples (continued)



**Figure 21. White-LED Supply With Adjustable Brightness Control**  
Using a PWM Signal on the Enable Pin Efficiency Approx. Equals 86% at  $V_{IN} = 3\text{ V}$ ,  $I_{LED} = 15\text{ mA}$



A. A smaller output capacitor value for C2 causes a larger LED ripple.

**Figure 22. White-LED Supply With Adjustable Brightness Control**  
Using an Analog Signal on the Feedback Pin

## 9 Power Supply Recommendations

The device is designed to operate from an input voltage supply range from 1.8 V to 6 V. The output current of the input power supply must be rated according to the supply voltage, output voltage, and output current of TPS6104x-Q1.

## 10 Layout

### 10.1 Layout Guidelines

Typical for all switching power supplies, the layout is an important step in the design; especially at high peak currents and switching frequencies. If the layout is not carefully done, the regulator can show noise problems and duty cycle jitter.

Figure 23 provides an example of layout design with TPS6104x-Q1 device.

- The input capacitor must be placed as close as possible to the input pin for good input voltage filtering.
- The inductor and diode must be placed as close as possible to the switch pin to minimize the noise coupling into other circuits.
- Keeping the switching pin and plane area short helps in minimizing the radiated emissions. It is also important to have very low impedance switch plane to reduce the switching losses and hence a trade-off must be made between these two and the switching pin and plane must be optimized.
- Because the feedback pin and network is noise-sensitive, the feedback network must be routed away from the inductor.
- The feedback pin and feedback network must be shielded with a ground plane or trace to minimize noise coupling into this circuit.
- A star ground connection or ground plane minimizes ground shifts and noise.

### 10.2 Layout Example

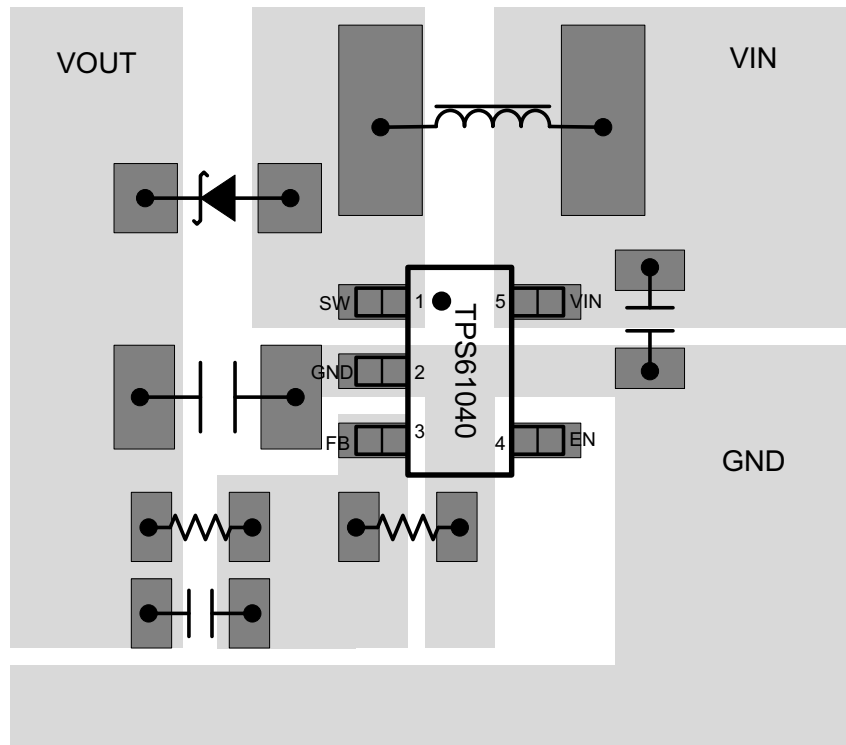

Figure 23. Layout Diagram

## 11 Device and Documentation Support

### 11.1 Device Support

#### 11.1.1 Third-Party Products Disclaimer

TI'S PUBLICATION OF INFORMATION REGARDING THIRD-PARTY PRODUCTS OR SERVICES DOES NOT CONSTITUTE AN ENDORSEMENT REGARDING THE SUITABILITY OF SUCH PRODUCTS OR SERVICES OR A WARRANTY, REPRESENTATION OR ENDORSEMENT OF SUCH PRODUCTS OR SERVICES, EITHER ALONE OR IN COMBINATION WITH ANY TI PRODUCT OR SERVICE.

### 11.2 Related Links

The table below lists quick access links. Categories include technical documents, support and community resources, tools and software, and quick access to sample or buy.

**Table 6. Related Links**

PARTS	PRODUCT FOLDER	SAMPLE & BUY	TECHNICAL DOCUMENTS	TOOLS & SOFTWARE	SUPPORT & COMMUNITY
TPS61040-Q1	<a href="#">Click here</a>	<a href="#">Click here</a>	<a href="#">Click here</a>	<a href="#">Click here</a>	<a href="#">Click here</a>
TPS61041-Q1	<a href="#">Click here</a>	<a href="#">Click here</a>	<a href="#">Click here</a>	<a href="#">Click here</a>	<a href="#">Click here</a>

### 11.3 Community Resource

The following links connect to TI community resources. Linked contents are provided "AS IS" by the respective contributors. They do not constitute TI specifications and do not necessarily reflect TI's views; see TI's [Terms of Use](#).

**TI E2E™ Online Community** *TI's Engineer-to-Engineer (E2E) Community*. Created to foster collaboration among engineers. At [e2e.ti.com](http://e2e.ti.com), you can ask questions, share knowledge, explore ideas and help solve problems with fellow engineers.

**Design Support** *TI's Design Support* Quickly find helpful E2E forums along with design support tools and contact information for technical support.

### 11.4 Trademarks

E2E is a trademark of Texas Instruments.  
All other trademarks are the property of their respective owners.

### 11.5 Electrostatic Discharge Caution



These devices have limited built-in ESD protection. The leads should be shorted together or the device placed in conductive foam during storage or handling to prevent electrostatic damage to the MOS gates.

### 11.6 Glossary

**SLYZ022** — *TI Glossary*.

This glossary lists and explains terms, acronyms, and definitions.

## 12 Mechanical, Packaging, and Orderable Information

The following pages include mechanical, packaging, and orderable information. This information is the most current data available for the designated devices. This data is subject to change without notice and revision of this document. For browser-based versions of this data sheet, refer to the left-hand navigation.

**PACKAGING INFORMATION**

Orderable Device	Status (1)	Package Type	Package Drawing	Pins	Package Qty	Eco Plan (2)	Lead/Ball Finish (6)	MSL Peak Temp (3)	Op Temp (°C)	Device Marking (4/5)	Samples
TPS61040QDBVRQ1	ACTIVE	SOT-23	DBV	5	3000	Green (RoHS & no Sb/Br)	CU NIPDAU	Level-1-260C-UNLIM	-40 to 125	PHOQ	<a href="#">Samples</a>
TPS61041QDBVRQ1	ACTIVE	SOT-23	DBV	5	3000	Green (RoHS & no Sb/Br)	CU NIPDAU	Level-1-260C-UNLIM	-40 to 125	PHPQ	<a href="#">Samples</a>

(1) The marketing status values are defined as follows:

**ACTIVE:** Product device recommended for new designs.

**LIFEBUY:** TI has announced that the device will be discontinued, and a lifetime-buy period is in effect.

**NRND:** Not recommended for new designs. Device is in production to support existing customers, but TI does not recommend using this part in a new design.

**PREVIEW:** Device has been announced but is not in production. Samples may or may not be available.

**OBSELETE:** TI has discontinued the production of the device.

(2) Eco Plan - The planned eco-friendly classification: Pb-Free (RoHS), Pb-Free (RoHS Exempt), or Green (RoHS & no Sb/Br) - please check <http://www.ti.com/productcontent> for the latest availability information and additional product content details.

**TBD:** The Pb-Free/Green conversion plan has not been defined.

**Pb-Free (RoHS):** TI's terms "Lead-Free" or "Pb-Free" mean semiconductor products that are compatible with the current RoHS requirements for all 6 substances, including the requirement that lead not exceed 0.1% by weight in homogeneous materials. Where designed to be soldered at high temperatures, TI Pb-Free products are suitable for use in specified lead-free processes.

**Pb-Free (RoHS Exempt):** This component has a RoHS exemption for either 1) lead-based flip-chip solder bumps used between the die and package, or 2) lead-based die adhesive used between the die and leadframe. The component is otherwise considered Pb-Free (RoHS compatible) as defined above.

**Green (RoHS & no Sb/Br):** TI defines "Green" to mean Pb-Free (RoHS compatible), and free of Bromine (Br) and Antimony (Sb) based flame retardants (Br or Sb do not exceed 0.1% by weight in homogeneous material)

(3) MSL, Peak Temp. - The Moisture Sensitivity Level rating according to the JEDEC industry standard classifications, and peak solder temperature.

(4) There may be additional marking, which relates to the logo, the lot trace code information, or the environmental category on the device.

(5) Multiple Device Markings will be inside parentheses. Only one Device Marking contained in parentheses and separated by a "~" will appear on a device. If a line is indented then it is a continuation of the previous line and the two combined represent the entire Device Marking for that device.

(6) Lead/Ball Finish - Orderable Devices may have multiple material finish options. Finish options are separated by a vertical ruled line. Lead/Ball Finish values may wrap to two lines if the finish value exceeds the maximum column width.

**Important Information and Disclaimer:** The information provided on this page represents TI's knowledge and belief as of the date that it is provided. TI bases its knowledge and belief on information provided by third parties, and makes no representation or warranty as to the accuracy of such information. Efforts are underway to better integrate information from third parties. TI has taken and continues to take reasonable steps to provide representative and accurate information but may not have conducted destructive testing or chemical analysis on incoming materials and chemicals. TI and TI suppliers consider certain information to be proprietary, and thus CAS numbers and other limited information may not be available for release.

In no event shall TI's liability arising out of such information exceed the total purchase price of the TI part(s) at issue in this document sold by TI to Customer on an annual basis.

**OTHER QUALIFIED VERSIONS OF TPS61040-Q1, TPS61041-Q1 :**

- Catalog: [TPS61040](#), [TPS61041](#)

**NOTE: Qualified Version Definitions:**

- Catalog - TI's standard catalog product

## TAPE AND REEL INFORMATION



### QUADRANT ASSIGNMENTS FOR PIN 1 ORIENTATION IN TAPE



\*All dimensions are nominal

Device	Package Type	Package Drawing	Pins	SPQ	Reel Diameter (mm)	Reel Width W1 (mm)	A0 (mm)	B0 (mm)	K0 (mm)	P1 (mm)	W (mm)	Pin1 Quadrant
TPS61040QDBVRQ1	SOT-23	DBV	5	3000	180.0	9.0	3.15	3.2	1.4	4.0	8.0	Q3
TPS61041QDBVRQ1	SOT-23	DBV	5	3000	180.0	9.0	3.15	3.2	1.4	4.0	8.0	Q3

**TAPE AND REEL BOX DIMENSIONS**

\*All dimensions are nominal

Device	Package Type	Package Drawing	Pins	SPQ	Length (mm)	Width (mm)	Height (mm)
TPS61040QDBVRQ1	SOT-23	DBV	5	3000	182.0	182.0	20.0
TPS61041QDBVRQ1	SOT-23	DBV	5	3000	182.0	182.0	20.0

DBV0005A



# PACKAGE OUTLINE

SOT-23 - 1.45 mm max height

SMALL OUTLINE TRANSISTOR



4214839/D 11/2018

## NOTES:

1. All linear dimensions are in millimeters. Any dimensions in parenthesis are for reference only. Dimensioning and tolerancing per ASME Y14.5M.
2. This drawing is subject to change without notice.
3. Reference JEDEC MO-178.
4. Body dimensions do not include mold flash, protrusions, or gate burrs. Mold flash, protrusions, or gate burrs shall not exceed 0.15 mm per side.

# EXAMPLE BOARD LAYOUT

DBV0005A

SOT-23 - 1.45 mm max height

SMALL OUTLINE TRANSISTOR



LAND PATTERN EXAMPLE  
EXPOSED METAL SHOWN  
SCALE:15X



SOLDER MASK DETAILS

4214839/D 11/2018

NOTES: (continued)

- 5. Publication IPC-7351 may have alternate designs.
- 6. Solder mask tolerances between and around signal pads can vary based on board fabrication site.

# EXAMPLE STENCIL DESIGN

DBV0005A

SOT-23 - 1.45 mm max height

SMALL OUTLINE TRANSISTOR



SOLDER PASTE EXAMPLE  
BASED ON 0.125 mm THICK STENCIL  
SCALE:15X

4214839/D 11/2018

NOTES: (continued)

7. Laser cutting apertures with trapezoidal walls and rounded corners may offer better paste release. IPC-7525 may have alternate design recommendations.
8. Board assembly site may have different recommendations for stencil design.

## IMPORTANT NOTICE AND DISCLAIMER

TI PROVIDES TECHNICAL AND RELIABILITY DATA (INCLUDING DATASHEETS), DESIGN RESOURCES (INCLUDING REFERENCE DESIGNS), APPLICATION OR OTHER DESIGN ADVICE, WEB TOOLS, SAFETY INFORMATION, AND OTHER RESOURCES "AS IS" AND WITH ALL FAULTS, AND DISCLAIMS ALL WARRANTIES, EXPRESS AND IMPLIED, INCLUDING WITHOUT LIMITATION ANY IMPLIED WARRANTIES OF MERCHANTABILITY, FITNESS FOR A PARTICULAR PURPOSE OR NON-INFRINGEMENT OF THIRD PARTY INTELLECTUAL PROPERTY RIGHTS.

These resources are intended for skilled developers designing with TI products. You are solely responsible for (1) selecting the appropriate TI products for your application, (2) designing, validating and testing your application, and (3) ensuring your application meets applicable standards, and any other safety, security, or other requirements. These resources are subject to change without notice. TI grants you permission to use these resources only for development of an application that uses the TI products described in the resource. Other reproduction and display of these resources is prohibited. No license is granted to any other TI intellectual property right or to any third party intellectual property right. TI disclaims responsibility for, and you will fully indemnify TI and its representatives against, any claims, damages, costs, losses, and liabilities arising out of your use of these resources.

TI's products are provided subject to TI's Terms of Sale ([www.ti.com/legal/termsofsale.html](http://www.ti.com/legal/termsofsale.html)) or other applicable terms available either on [ti.com](http://ti.com) or provided in conjunction with such TI products. TI's provision of these resources does not expand or otherwise alter TI's applicable warranties or warranty disclaimers for TI products.

Mailing Address: Texas Instruments, Post Office Box 655303, Dallas, Texas 75265  
Copyright © 2019, Texas Instruments Incorporated

## Looking for pricing, stock, or lifecycle information?

Click below to explore more details on WIN SOURCE:

 [View TPS61041QDBVRQ1 on WIN SOURCE](#)

 [Texas Instruments](#) Information

## Optimize Your Supply Chain with WIN SOURCE Solutions

-  Global Sourcing Solution
-  Obsolete Management
-  Cost Control Management
-  Shortage Management
-  Alternative Solution
-  Excess Inventory Management