

TLP2200

Isolated Bus Driver
 High Speed Line Receiver
 Microprocessor System Interfaces
 MOS FET Gate Driver
 Direct Replacement for HCPL-2200

The TOSHIBA TLP2200 consists of a GaAlAs light emitting diode and integrated high gain, high speed photodetector. This unit is 8-lead DIP package.
 The detector has a three state output stage that eliminates the need for pull-up resistor, and built-in Schmitt trigger. The detector IC has an internal shield that provides a guaranteed common mode transient immunity of 1000V / μ s.

- Input current: $I_F = 1.6 \text{ mA}$
- Power supply voltage: $V_{CC} = 4.5 \text{ to } 20 \text{ V}$
- Switching speed: 2.5MBd guaranteed
- Common mode transient immunity: $\pm 1000\text{V} / \mu\text{s}$ (min)
- Guaranteed performance over temperature: 0 to 85°C
- Isolation voltage: 2500 Vrms (min)
- UL approval: UL1577, File No.E67349 Under application
- cUL approved :CSA Component Acceptance Service No. 5A, File No.E67349

Truth Table (positive logic)

Input	Enable	Output
H	H	Z
L	H	Z
H	L	H
L	L	L

Unit: mm

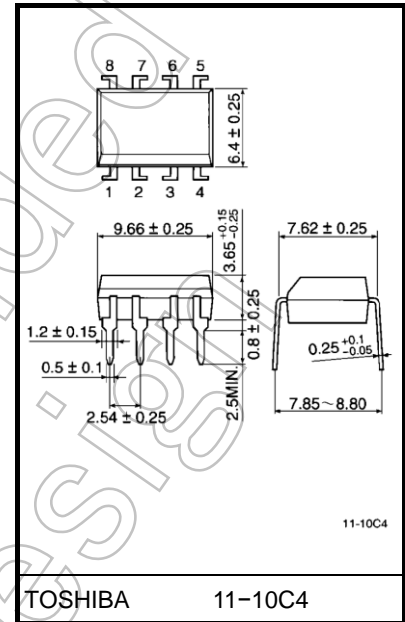

Weight: 0.54 g (typ.)

Pin Configuration (top view)

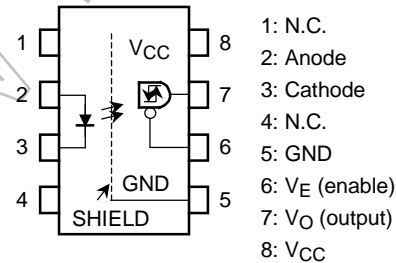

Schematic

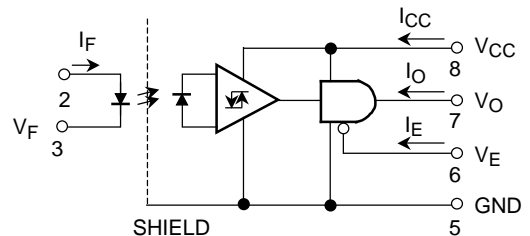

Start of commercial production
 1986-07

Recommended Operating Conditions

Characteristic	Symbol	Min	Typ.	Max	Unit
Input current, on	I _{F(ON)}	1.6	—	5	mA
Input current, off	I _{F(OFF)}	0	—	0.1	mA
Supply voltage	V _{CC}	4.5	—	20	V
Enable voltage high	V _{EH}	2.0	—	20	V
Enable voltage low	V _{EL}	0	—	0.8	V
Fan out (TTL load)	N	—	—	4	—
Operating temperature	T _{opr}	0	—	85	°C

Note: Recommended operating conditions are given as a design guideline to obtain expected performance of the device. Additionally, each item is an independent guideline respectively. In developing designs using this product, please confirm specified characteristics shown in this document.

Absolute Maximum Ratings (no derating required up to 70°C)

Characteristic	Symbol	Rating	Unit
Input	Forward current	I _F	10 mA
	Peak transient forward current (Note 1)	I _{FPT}	1 A
	Reverse voltage	V _R	5 V
	Input Power Dissipation	P _D	45 mW
	Input power dissipation derating (T _a ≥ 70°C)	ΔP _D /ΔT _a	-0.86 mW/°C
Output	Output current	I _O	25 mA
	Supply voltage	V _{CC}	-0.5 to 20 V
	Output voltage	V _O	-0.5 to 20 V
	Three state enable voltage	V _E	-0.5 to 20 V
	Output Power Dissipation	P _O	100 mW
	Output Power Dissipation Derating (T _a ≥ 70°C)	ΔP _O /°C	-1.9 mW/°C
	Total package power dissipation (Note 2)	P _T	210 mW
Operating temperature range	T _{opr}	-40 to 85	°C
Storage temperature range	T _{stg}	-55 to 125	°C
Lead solder temperature (10s) (**)	T _{sol}	260	°C
Isolation voltage (AC 1minute, R.H. ≤ 60%, T _a = 25°C) (Note 3)	BV _S	2500	V _{rms}

Note: Using continuously under heavy loads (e.g. the application of high temperature/current/voltage and the significant change in temperature, etc.) may cause this product to decrease in the reliability significantly even if the operating conditions (i.e. operating temperature/current/voltage, etc.) are within the absolute maximum ratings.

Please design the appropriate reliability upon reviewing the Toshiba Semiconductor Reliability Handbook ("Handling Precautions"/"Derating Concept and Methods") and individual reliability data (i.e. reliability test report and estimated failure rate, etc).

(Note 1) Pulse width 1μs, 300 pps.

(Note 2) Derate 4.5mW / °C above 70°C ambient temperature.

(Note 3) Device considered a two terminal device: Pins 1, 2, 3 and 4 shorted together, and pins 5,6,7 and 8 shorted together

(**) 1.6mm below seating plane.

Electrical Characteristics (unless otherwise specified, Ta = 0 to 85°C, VCC = 4.5 to 20V, IF(ON) = 1.6 to 5mA, IF(OFF) = 0 to 0.1mA, VEL = 0 to 0.8V, VEH = 2.0 to 20V)

Characteristic	Symbol	Test Condition		Min	Typ.*	Max	Unit
Output leakage current (VO > VCC)	IOHH	IF = 5mA, VCC = 4.5V	VO = 5.5V	—	—	100	μA
			VO = 20V	—	2	500	
Logic low output voltage	VOL	IOL = 6.4mA (4 TTL load)		—	0.32	0.5	V
Logic high output voltage	VOH	IOH = -2.6mA		2.4	3.4	—	V
Logic low enable current	IEL	VE = 0.4V		—	-0.13	-0.32	mA
Logic high enable current	IEH	VE = 2.7V		—	—	20	μA
		VE = 5.5V		—	—	100	
		VE = 20V		—	0.01	250	
Logic low enable voltage	VEL	—		—	—	0.8	V
Logic high enable voltage	VEH	—		2.0	—	—	V
Logic low supply current	ICCL	IF = 0mA, VE = don't care	VCC = 5.5V	—	5	6.0	mA
			VCC = 20V	—	5.6	7.5	
Logic high supply current	ICCH	IF = 5mA, VE = don't care	VCC = 5.5V	—	2.5	4.5	mA
			VCC = 20V	—	2.8	6.0	
High impedance state output current	IOZL	IF = 5mA, VE = 2V	VO = 0.4V	—	1	-20	μA
			VO = 2.4V	—	—	20	
	IOZH	IF = 0mA, VE = 2V	VO = 5.5V	—	—	100	
			VO = 20V	—	0.01	500	
Logic low short circuit output current (Note 4)	IOSL	IF = 0mA	VO = VCC = 5.5V	25	55	—	mA
			VO = VCC = 20V	40	80	—	
Logic high short circuit output current (Note 4)	IOSH	IF = 5mA, VO = GND	VCC = 5.5V	-10	-25	—	mA
			VCC = 20V	-25	-60	—	
Input current hysteresis	IHYS	VCC = 5V		—	0.05	—	mA
Input forward voltage	VF	IF = 5mA, Ta = 25°C		—	1.55	1.7	V
Temperature coefficient of forward voltage	ΔVF / ΔTa	IF = 5mA		—	-2.0	—	mV / °C
Input reverse breakdown voltage	BVR	IR = 10μA, Ta = 25°C		5	—	—	V
Input capacitance	CIN	VF = 0V, f = 1MHz, Ta = 25°C		—	45	—	pF
Resistance (input-output)	RI-O	VI-O = 500V R.H. ≤ 60% (Note 3)		5×10 ¹⁰	10 ¹⁴	—	Ω
Capacitance (input-output)	CI-O	VI-O = 0V, f = 1MHz (Note 3)		—	0.6	—	pF

(**) All typ. values are at Ta = 25°C, VCC = 5V, IF(ON) = 3mA unless otherwise specified.

Switching Characteristics

(unless otherwise specified, $T_a = 0$ to 85°C , $V_{CC} = 4.5$ to 20V , $I_{F(ON)} = 1.6$ to 5mA , $I_{F(OFF)} = 0$ to 0.1mA)

Characteristic	Symbol	Test Circuit	Test Condition	Min	Typ.	Max	Unit
Propagation delay time to logic high output level (Note 5)	t_{pLH}	1	Without peaking capacitor C_1	—	235	—	ns
			With peaking capacitor C_1	—	—	400	
Propagation delay time to logic low output level (Note 5)	t_{pHL}		Without peaking capacitor C_1	—	250	—	ns
			With peaking capacitor C_1	—	—	400	
Output rise time (10–90%)	t_r		—	—	35	—	ns
Output fall time (90–10%)	t_f		—	—	20	—	ns
Common mode transient immunity at logic high output (Note 6)	CMH	3	$I_F = 1.6\text{mA}$, $V_{CM} = 50\text{V}$, $T_a = 25^\circ\text{C}$	-1000	—	—	$\text{V} / \mu\text{s}$
Common mode transient immunity at logic low output (Note 6)	CML		$I_F = 0\text{mA}$, $V_{CM} = 50\text{V}$, $T_a = 25^\circ\text{C}$	1000	—	—	$\text{V} / \mu\text{s}$

(*) All typ. values are at $T_a = 25^\circ\text{C}$, $V_{CC} = 5\text{V}$, $I_{F(ON)} = 3\text{mA}$ unless otherwise specified.

(Note 4) Duration of output short circuit time should not exceed 10ms.

(Note 5) The t_{pLH} propagation delay is measured from the 50% point on the leading edge of the input pulse to the 1.3V point on the leading edge of the output pulse.
The t_{pHL} propagation delay is measured from the 50% point on the trailing edge of the input pulse to the 1.3V point on the trailing edge of the output pulse.

(Note 6) CML is the maximum rate of rise of the common mode voltage that can be sustained with the output voltage in the logic low state ($V_O < 0.8\text{V}$).
CMH is the maximum rate of fall of the common mode voltage that can be sustained with the output voltage in the logic high state ($V_O > 2.0\text{V}$).

Not Recommended for New Design

Test Circuit 1 t_{pHL} , t_{pLH} , t_r and t_f

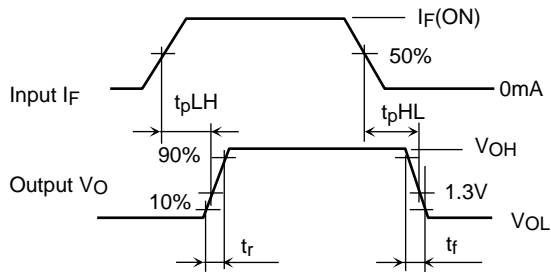

R1	2.15kΩ	1.1kΩ	681Ω
IF(ON)	1.6mA	3mA	5mA

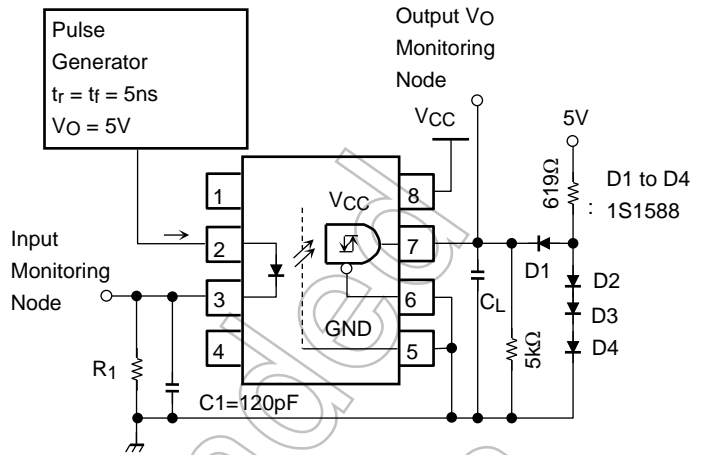

C1 is peaking capacitor. The probe and jig capacitances are included in C1.
 CL is approximately 15pF which includes probe and stray wiring capacitance.

Test Circuit 2 t_{pHZ} , t_{pZH} , t_{pLZ} and t_{pZL}

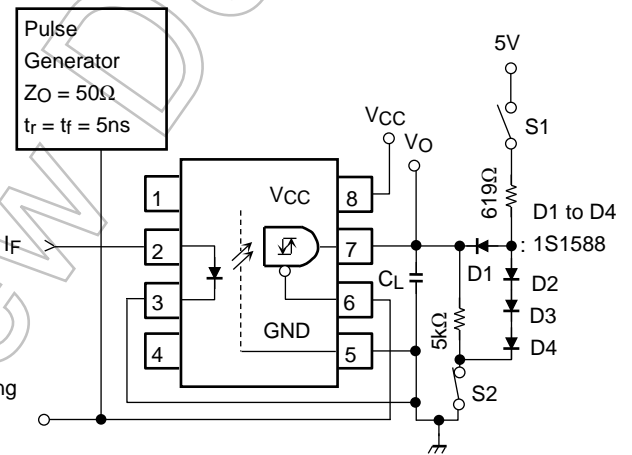
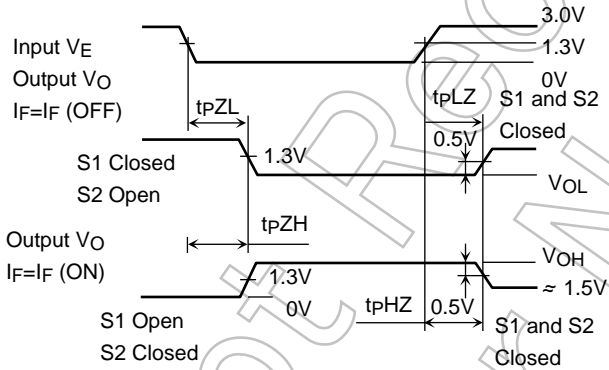

CL is approximately 15pF which includes probe and stray wiring capacitance.

Test Circuit 3 Common Mode Transient Immunity

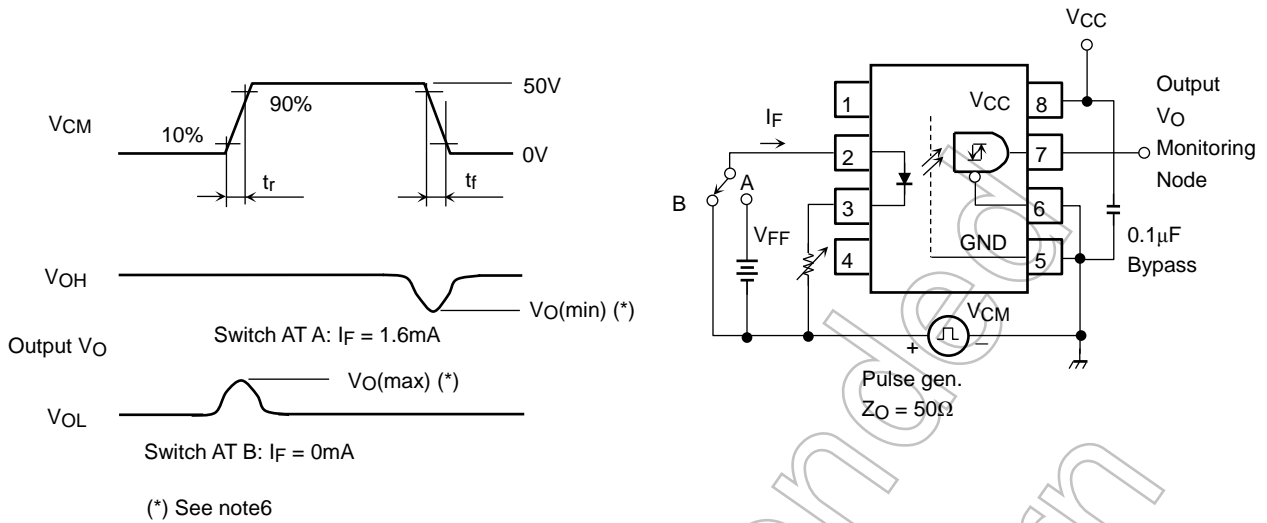

Not Recommended for New Design

RESTRICTIONS ON PRODUCT USE

Toshiba Corporation and its subsidiaries and affiliates are collectively referred to as "TOSHIBA". Hardware, software and systems described in this document are collectively referred to as "Product".

- TOSHIBA reserves the right to make changes to the information in this document and related Product without notice.
- This document and any information herein may not be reproduced without prior written permission from TOSHIBA. Even with TOSHIBA's written permission, reproduction is permissible only if reproduction is without alteration/omission.
- Though TOSHIBA works continually to improve Product's quality and reliability, Product can malfunction or fail. Customers are responsible for complying with safety standards and for providing adequate designs and safeguards for their hardware, software and systems which minimize risk and avoid situations in which a malfunction or failure of Product could cause loss of human life, bodily injury or damage to property, including data loss or corruption. Before customers use the Product, create designs including the Product, or incorporate the Product into their own applications, customers must also refer to and comply with (a) the latest versions of all relevant TOSHIBA information, including without limitation, this document, the specifications, the data sheets and application notes for Product and the precautions and conditions set forth in the "TOSHIBA Semiconductor Reliability Handbook" and (b) the instructions for the application with which the Product will be used with or for. Customers are solely responsible for all aspects of their own product design or applications, including but not limited to (a) determining the appropriateness of the use of this Product in such design or applications; (b) evaluating and determining the applicability of any information contained in this document, or in charts, diagrams, programs, algorithms, sample application circuits, or any other referenced documents; and (c) validating all operating parameters for such designs and applications. **TOSHIBA ASSUMES NO LIABILITY FOR CUSTOMERS' PRODUCT DESIGN OR APPLICATIONS.**
- **PRODUCT IS NEITHER INTENDED NOR WARRANTED FOR USE IN EQUIPMENTS OR SYSTEMS THAT REQUIRE EXTRAORDINARILY HIGH LEVELS OF QUALITY AND/OR RELIABILITY, AND/OR A MALFUNCTION OR FAILURE OF WHICH MAY CAUSE LOSS OF HUMAN LIFE, BODILY INJURY, SERIOUS PROPERTY DAMAGE AND/OR SERIOUS PUBLIC IMPACT ("UNINTENDED USE").** Except for specific applications as expressly stated in this document, Unintended Use includes, without limitation, equipment used in nuclear facilities, equipment used in the aerospace industry, medical equipment, equipment used for automobiles, trains, ships and other transportation, traffic signaling equipment, equipment used to control combustions or explosions, safety devices, elevators and escalators, devices related to electric power, and equipment used in finance-related fields. **IF YOU USE PRODUCT FOR UNINTENDED USE, TOSHIBA ASSUMES NO LIABILITY FOR PRODUCT.** For details, please contact your TOSHIBA sales representative.
- Do not disassemble, analyze, reverse-engineer, alter, modify, translate or copy Product, whether in whole or in part.
- Product shall not be used for or incorporated into any products or systems whose manufacture, use, or sale is prohibited under any applicable laws or regulations.
- The information contained herein is presented only as guidance for Product use. No responsibility is assumed by TOSHIBA for any infringement of patents or any other intellectual property rights of third parties that may result from the use of Product. No license to any intellectual property right is granted by this document, whether express or implied, by estoppel or otherwise.
- **ABSENT A WRITTEN SIGNED AGREEMENT, EXCEPT AS PROVIDED IN THE RELEVANT TERMS AND CONDITIONS OF SALE FOR PRODUCT, AND TO THE MAXIMUM EXTENT ALLOWABLE BY LAW, TOSHIBA (1) ASSUMES NO LIABILITY WHATSOEVER, INCLUDING WITHOUT LIMITATION, INDIRECT, CONSEQUENTIAL, SPECIAL, OR INCIDENTAL DAMAGES OR LOSS, INCLUDING WITHOUT LIMITATION, LOSS OF PROFITS, LOSS OF OPPORTUNITIES, BUSINESS INTERRUPTION AND LOSS OF DATA, AND (2) DISCLAIMS ANY AND ALL EXPRESS OR IMPLIED WARRANTIES AND CONDITIONS RELATED TO SALE, USE OF PRODUCT, OR INFORMATION, INCLUDING WARRANTIES OR CONDITIONS OF MERCHANTABILITY, FITNESS FOR A PARTICULAR PURPOSE, ACCURACY OF INFORMATION, OR NONINFRINGEMENT.**
- GaAs (Gallium Arsenide) is used in Product. GaAs is harmful to humans if consumed or absorbed, whether in the form of dust or vapor. Handle with care and do not break, cut, crush, grind, dissolve chemically or otherwise expose GaAs in Product.
- Do not use or otherwise make available Product or related software or technology for any military purposes, including without limitation, for the design, development, use, stockpiling or manufacturing of nuclear, chemical, or biological weapons or missile technology products (mass destruction weapons). Product and related software and technology may be controlled under the applicable export laws and regulations including, without limitation, the Japanese Foreign Exchange and Foreign Trade Law and the U.S. Export Administration Regulations. Export and re-export of Product or related software or technology are strictly prohibited except in compliance with all applicable export laws and regulations.
- Please contact your TOSHIBA sales representative for details as to environmental matters such as the RoHS compatibility of Product. Please use Product in compliance with all applicable laws and regulations that regulate the inclusion or use of controlled substances, including without limitation, the EU RoHS Directive. **TOSHIBA ASSUMES NO LIABILITY FOR DAMAGES OR LOSSES OCCURRING AS A RESULT OF NONCOMPLIANCE WITH APPLICABLE LAWS AND REGULATIONS.**

Looking for pricing, stock, or lifecycle information?

Click below to explore more details on WIN SOURCE:

- [View TLP2200\(TP1,F\) on WIN SOURCE](#)
- [Toshiba Semiconductor and Storage Information](#)

Optimize Your Supply Chain with WIN SOURCE Solutions

- ✓ Global Sourcing Solution
- ✓ Obsolete Management
- ✓ Cost Control Management
- ✓ Shortage Management
- ✓ Alternative Solution
- ✓ Excess Inventory Management