

# Smart Sensors zs Series

2D CMOS Laser Type

High-precision Displacement Measurement Sensors Bringing Smart

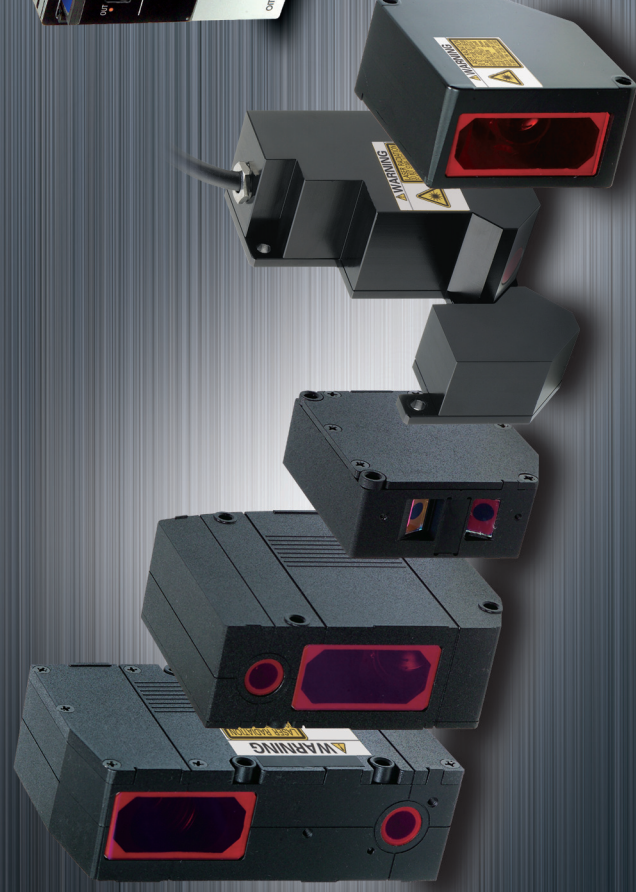

realizing

# ZS-HL Series

More P.6

Very High-performance Sensors that Support Core Quality from Very Long-range to Extremely Precise Measurements

- Range of models with measuring center distance of 20 to 1,500 mm.
- Achieves maximum resolution of 0.25  $\mu\text{m}$ .
- Maximum response speed of 110  $\mu\text{s}$ .
- Parallel output supported.

Highly Advan



Measuring center distance

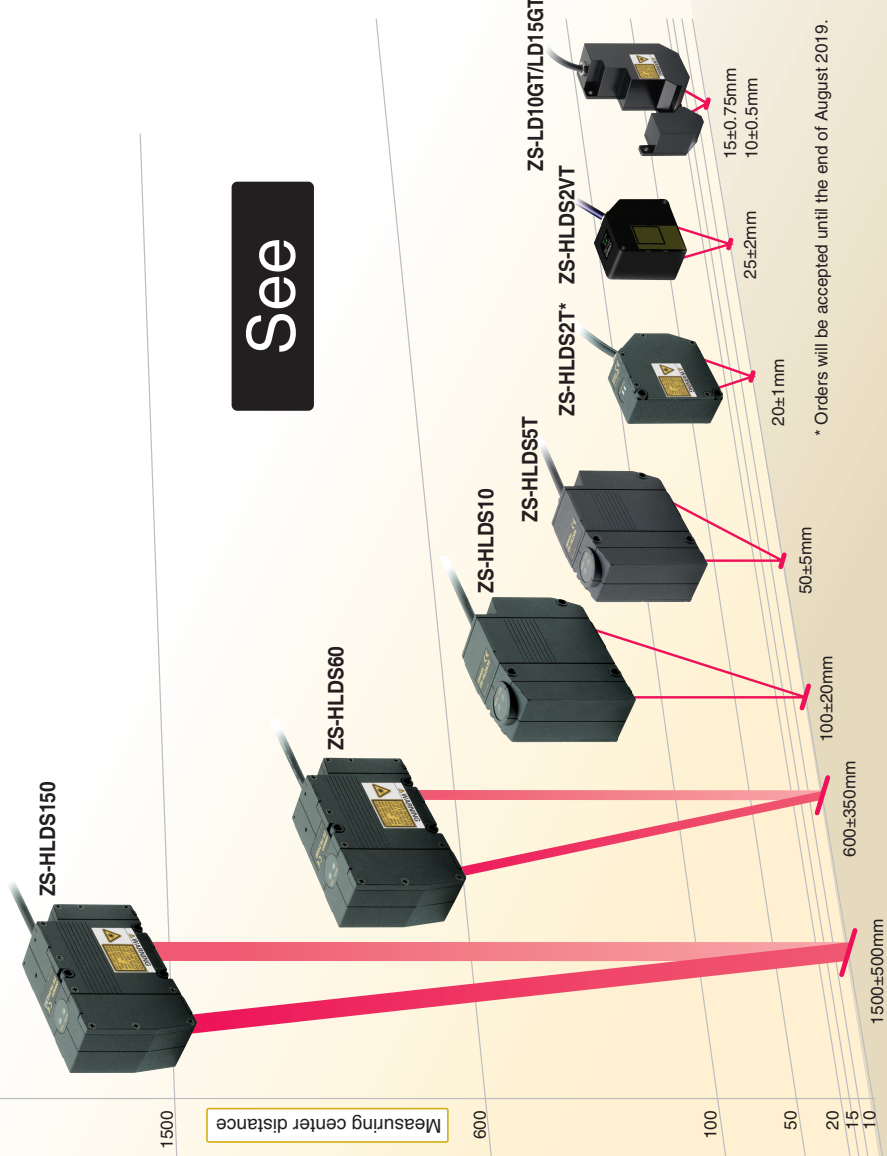

See

Record

## Data Storage Unit ZS-DSU Ideal for ZS Series Data Logging

Enables onsite high-speed logging of data in memory (compact flash card) for the Sensor Multi-Controller.

Effective for building traceability systems, statistical process control (SPC), and much more.

High-speed sampling rate: 150  $\mu\text{s}$   
Powerful support for logging data using various trigger functions.

More

\* Orders will be accepted until the end of August 2019.

# Smart Sensor

Advanced technology is carried

## Fact Package



## Monitor

**SmartMonitor**  
**Professional ZS-SW11E V3**  
**Setting Software for the ZS Series**

Meets a wide range of logging needs.  
 Supports high-speed simultaneous multichannel waveform graphs.  
 Excel macros provided for simple analysis.

More P.19

## ZS-L Series

More P.14

Standard Sensors Most Suitable for a Variety of High-precision Displacement Measurements, Including Spot Detection, Wide-range Detection, and Long-distance Detection.

- Beam Shapes
- Spot and line beam selection.
- Wide Range of Products
- Long-range, middle-range, and short-range models.

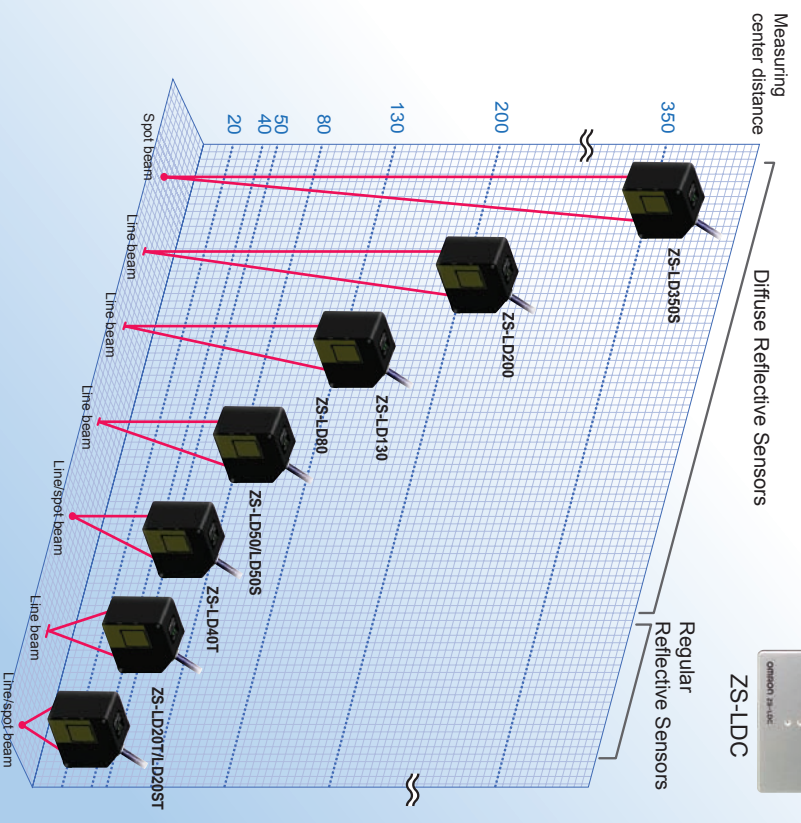

# Main Applications

## High Performance ZS-HL Series

Very High-performance Sensors that Support Core Quality from \ Extremely Precise Measurements



ZS-LD10GT/LD15GT

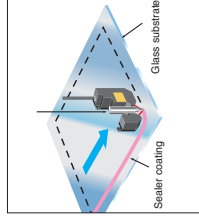

Ideal for measuring and controlling dispenser nozzle gaps when applying sealer.

ZS-HLDS2T\*

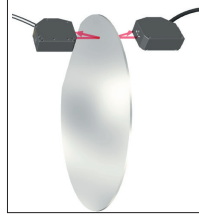

Ideal for measuring the thickness of silicone or compound semiconductor wafers in polishing and testing processes.

ZS-HLDS2VT

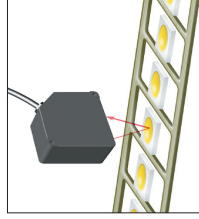

Ideal for measuring the potting resin height for electronic components.

ZS-HLDS5T

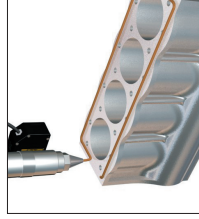

Ideal for measuring liquid gasket (FPIG) application amounts. Prevents defects such as insufficient seal.

ZS-HLDS10

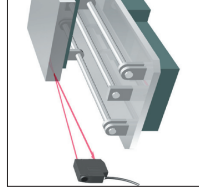

Ideal for confirming positioning and repeatability accuracy of XY stages.

\* Orders will be accepted until the end of August 2019.

## Standard ZS-L Series

Standard Sensors Ideal for a Variety of High-precision Displacement Measure Including Spot Detection, Wide-range Detection, and Long-distance Detection



ZS-LD20ST

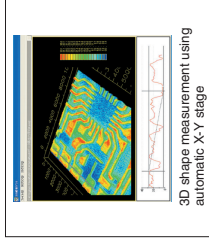

Ideal for measurements requiring discrimination between minute parts or fine shape repeatability.

ZS-LD40T

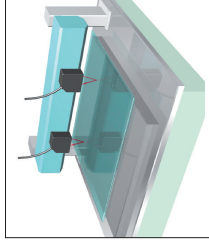

Ideal for measuring glass thickness and nozzle gaps when coating glass with resist or sealer.

ZS-LD50/LD80

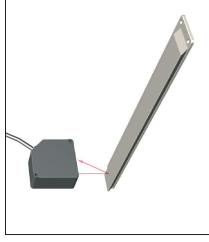

Ideal for measuring the warp of resin blades in copy machine toners.

ZS-LD200

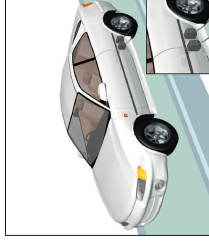

Ideal for checking the precision of door installations.

ZS-



Ideal for flatness that t load

# Smart Sensor

Advanced technology is carried

# Industry

Measuring Tire Extérieurs



Inspecting Board Heights

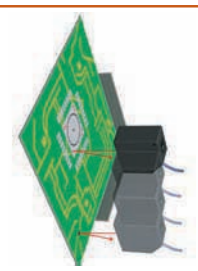

Inspecting for Board Coplanarity

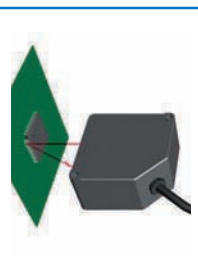

Measuring Shape for Positioning Laminated Ceramics

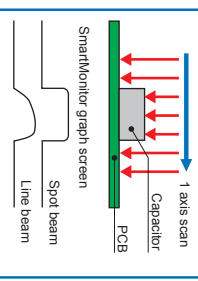

## Household Appliances and Audio-visual

Measuring Arm Inclination



Simultaneous Measuring of Touch Panel Film Thickness and Gap

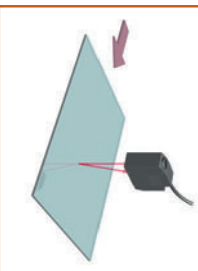

DVD Chassis Flatness Inspections

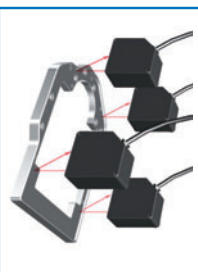

Digital Camera Tube Lens Inspection



## Rubber, Resin, and Film

Inspecting Glass Heights (Autofocus)

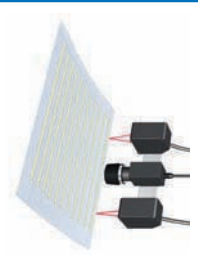

Measuring Electrode Thickness on Dielectrics



Moving Workpieces (Black Rubber)

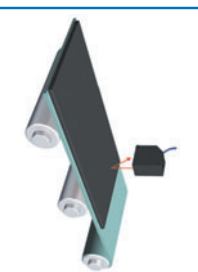

Measuring Depth of O-Ring Insertion

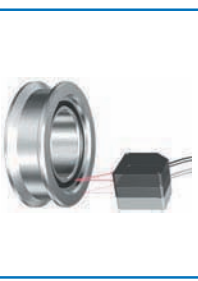

# High-performance Sensors

High grade

## ZS-HL Series Product Lineup 2D CMOS High-end Display

Advanced sensing technology packed into the best Sensor Head for the highest sensing

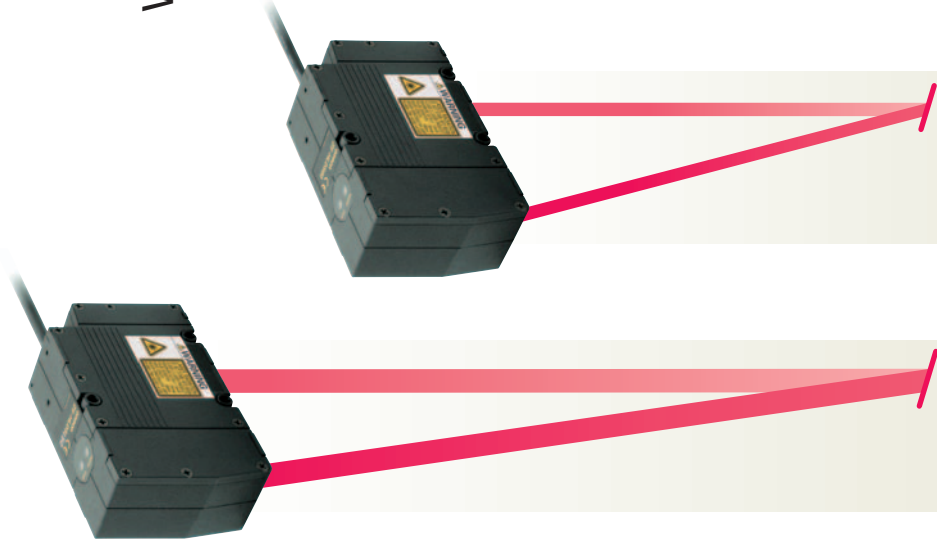

Wide lineup of products from 0.25  $\mu\text{m}$  high resolution to 1,500 mm measuring distance

Model	ZS-HLDS150	ZS-HLDS60	ZS-HLDS10	ZS-HLDS5T	ZS-HLDS2T*
Measuring center distance	1500 $\pm$ 500 mm	600 $\pm$ 350 mm	100 $\pm$ 20 mm	50 $\pm$ 5 mm	20 $\pm$ 1 mm
Resolution	500 $\mu\text{m}$	8 $\mu\text{m}$	1 $\mu\text{m}$	0.25 $\mu\text{m}$	0.25 $\mu\text{m}$
Linearity	$\pm$ 0.2%F.S.	$\pm$ 0.07%F.S.	$\pm$ 0.1%F.S.	$\pm$ 0.1%F.S.	$\pm$ 0.05%F.S.
Beam shape	1.5 mm x 40 mm	0.3 mm x 16 mm	60 $\mu\text{m}$ x 3.5 mm	30 $\mu\text{m}$ x 1 mm	20 $\mu\text{m}$ x 1 mm

\* Orders will be accepted until the end of August 2019.

## All Models Are Class 2 Lasers.

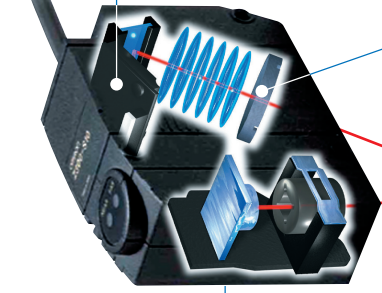

### Digital Sensing

Totally reliable measurements with completely digital sensing.

### 2D CMOS Laser Image Sensing Element

The three basics of sensing - precision, speed, and sensitivity - can be balanced because ideal measurement settings can be made for light reception area.

**±0.05% FS Linearity (ZS-HLDS2T)\***

Unique OMRON algorithms reduce detection error to improve workpiece measurement accuracy.

\* Orders will be accepted until the end of August 2019.

Very resolu

Extensi

High precision

### Extremely Sensitive Lenses

## Extreme Stability

### Ideal Size and Stability Head Size

Complete sensing stability with optimum Sensor Head size for best performance and holding mechanism secured at 3 points. (See note.)



ZS-HLDS2T\* ZS-HLDS5T/HLDS10

ZS-HLDS60/HLDS150



Note: ZS-HLDS2T not applicable.  
\* Orders will be accepted until the end of August 2019.

## Superior Moving Resolution Increased Lens Resolution

Moving resolution (error based on workpiece surface position) has been reduced dramatically by optimizing the optical system with increased sensitivity and resolution of the light receiving lenses.

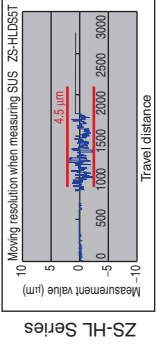
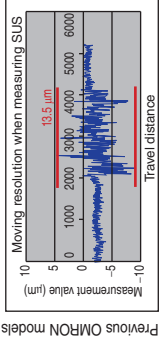

Sampling: 4 ms

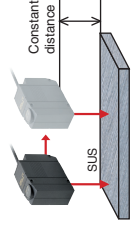

## Reduced 2D CM

With a C... excess... with CM... from dif...

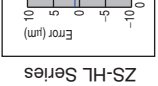
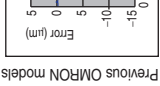

# High-performance Sensors

High grade

## ZS-HLDS5T/HLDS10 Detect Essentially Any Object

Reduced Variation in Linearity between  
Determines Measurement Accuracy  
Makes it easier to introduce a variety of

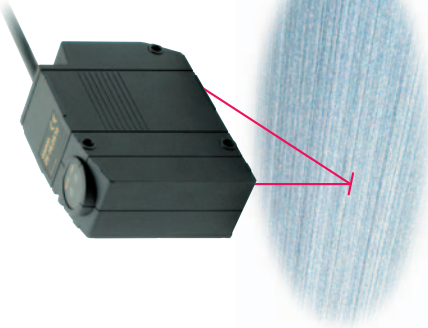

Model	<b>ZS-HLDS5T</b>
Measuring center distance	50±5 mm
Resolution	0.25 μm
Linearity	±0.1%F.S.
Beam shape	30 μm x 1 mm

Model	<b>ZS-HLDS10</b>
Measuring center distance	100±20 mm
Resolution	1 μm
Linearity	±0.1%F.S.
Beam shape	60 μm x 3.5 mm

### Linearity Characteristic

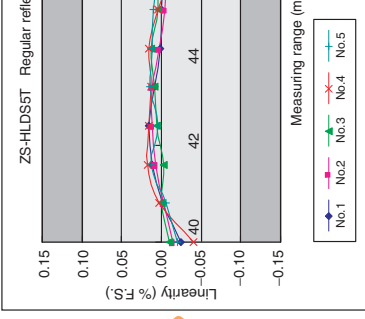
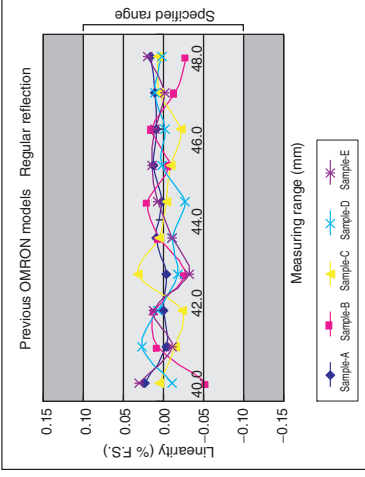

## ZS-HLDS60/HLDS150 A Long Range That Handles Essentially Any Installation

First 1,500 mm long range sensing in the industry  
impossible points.

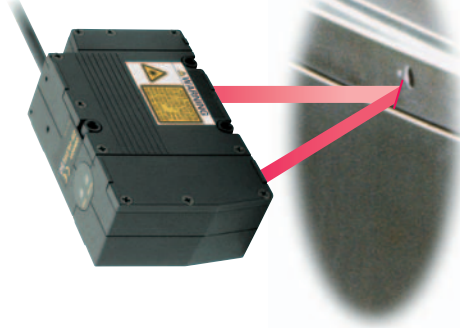

Model	<b>ZS-HLDS60</b>
Measuring center distance	600±350 mm
Resolution	8 μm
Linearity	±0.07%F.S.
Beam shape	0.3 mm x 16 mm

Model	<b>ZS-HLDS150</b>
Measuring center distance	1500±500 mm
Resolution	500 μm
Linearity	±0.2%F.S.
Beam shape	1.5 mm x 40 mm

### Simple Long-distance Step Measurement

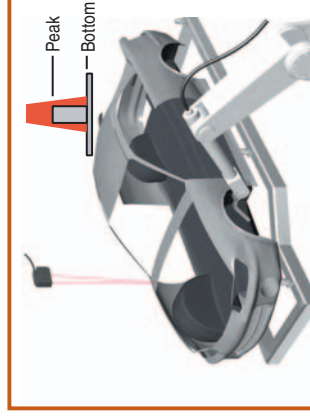

Peak/bottom measurement

## ZS-HLDS2VT Ideal for Measuring the Height and Thickness of Transparent Objects

Tilted and moving workpieces can also be stably measured.

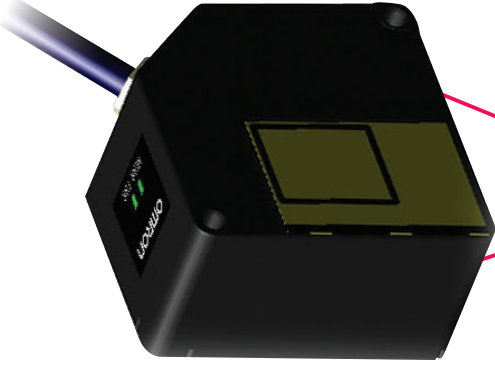

ZS-HLDS2VT	
Model	ZS-HLDS2VT
Measuring center distance	25±2 mm
Resolution	0.6 μm
Linearity	±0.2%F.S.
Beam shape	45 μm × 2.2 mm

A special aspherical lens was developed for the ZS-HLDS2VT, and the design of the optical structure was optimized for regular-reflective workpieces. This has greatly increased the allowable degree of tilt and improved stability for measuring transparent and regular-reflective workpieces.

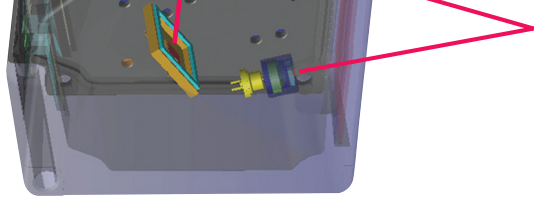

Angle Characteristics

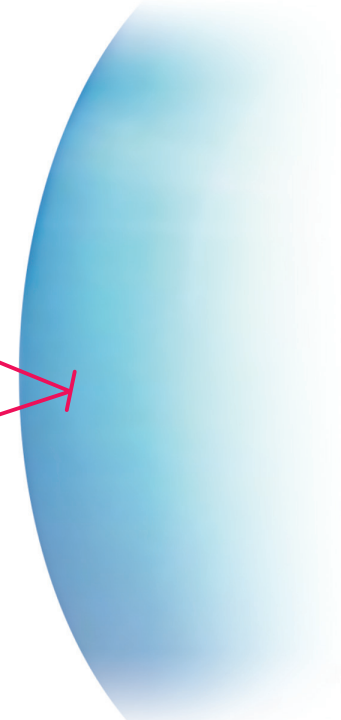
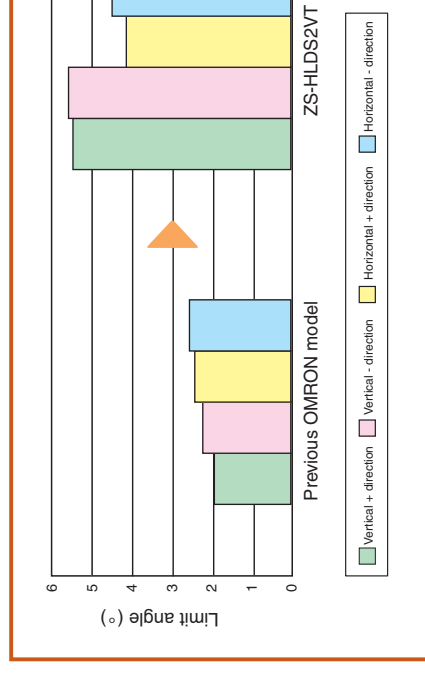

# High-performance Sensors

High grade

## ZS-HLDS2T\*/ZS-LD10GT/LD15GT

### The Only Way to Very High-precision Measurements

Superior Features for Semiconductor Wafer, Glass, and Other Measurements Requiring

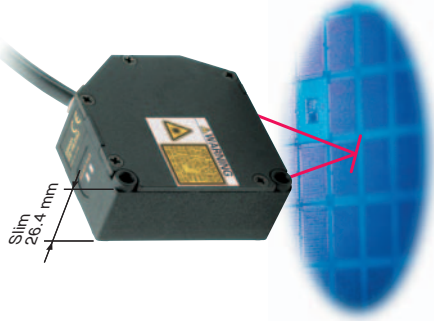

Model	ZS-HLDS2T*
Measuring center distance	20±1 mm
Resolution	0.25 μm
Linearity	±0.05%F.S.
Beam shape	20 μm x 1 mm

\* Orders will be accepted until the end of August 2019.

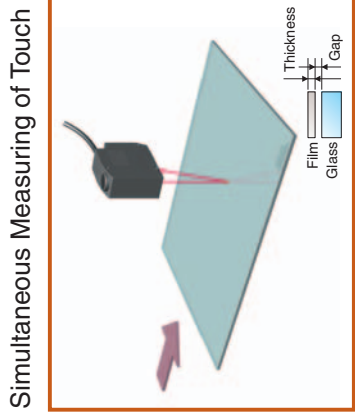

Simultaneous Measuring of Touch Panel Film Thickness and Gap

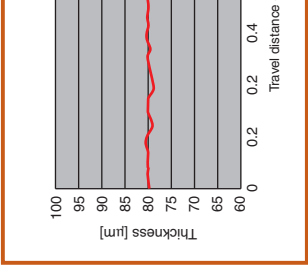

Simultaneous measurement of t

An unbelievable stationary measurement precision of 0.25 μm, the highest in this prod



Model	ZS-LD10GT/LD15GT
Measuring center distance	10±0.5 mm/15±0.75 mm
Resolution	0.25 μm
Linearity	±0.1%F.S.
Beam shape	25 x 900 μm

#### Ideal for Measuring Nozzle Gaps!

- Reduced pattern influence for moving measurement, the best in the moving resolution industry.
- Possible to match nozzle drip point and measurement point then measure.
- Sensor Head with separate light emission and reception in one unit to create nozzle space.

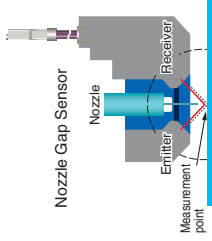

Height Control of Sealant Dispensers

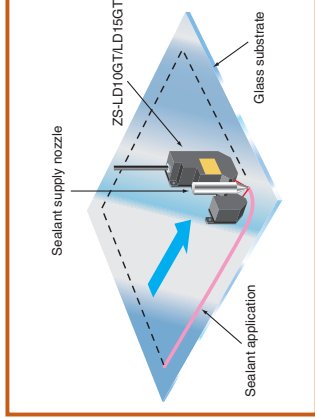

Inspection of Disk Play on HD

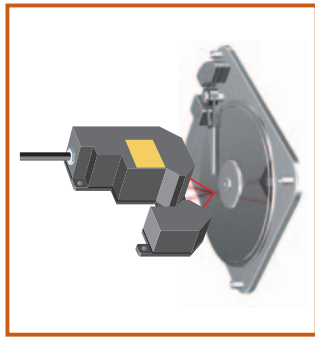

# Technology

With OMRON's sensing technology and newly developed algorithms, stable, high-precision measurement is possible to measure using laser displacement meters due to laser light penetration, transmission, excessive reflection, or in

Mechanisms for Stable Measurement **Patent Pending**

No more errors due to reflection coefficients between glass gaps

Stable measurement by adding received light waveform in 2D image and digital zoom processing.

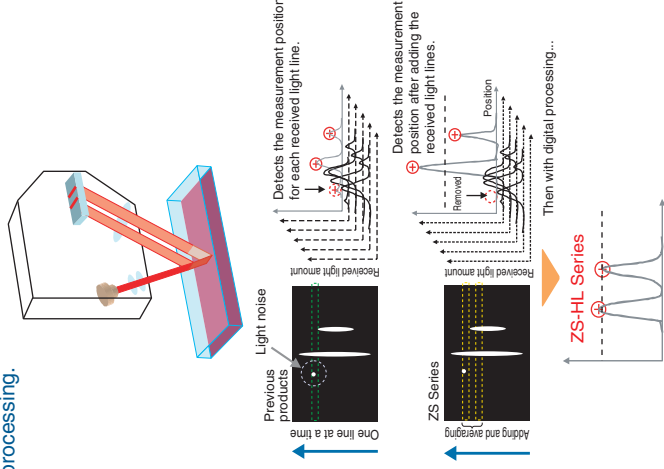

Measurement cycle time 1/8 better than previous models with addition of received light waveform captured by 2D CMOS and simultaneous measurement of front and back glass surfaces with separate sensitivities.

Mechanisms for Stable Measurement **Patent Pending**

No more errors due to workpiece reflection coefficients.

Stable measurement using laser power algorithms that can be adjusted to any value.

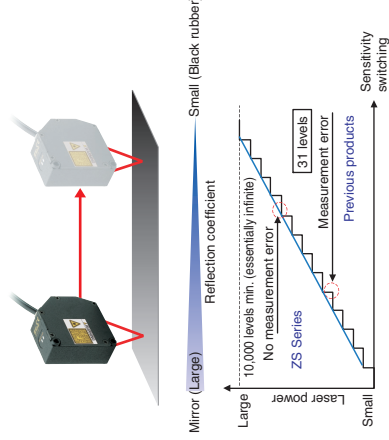

Light quantity adjustment algorithms have evolved for stable measurement of a variety of measurement objects.

Even if the workpiece status changes suddenly, the sensitivity can compensate at any level so there is no measurement error from sensitivity switching.

Mechanisms for High Resolution **Patent Pending**

No more resolution errors.

Digital processing technology between the Sensor and Controller provides high resolution

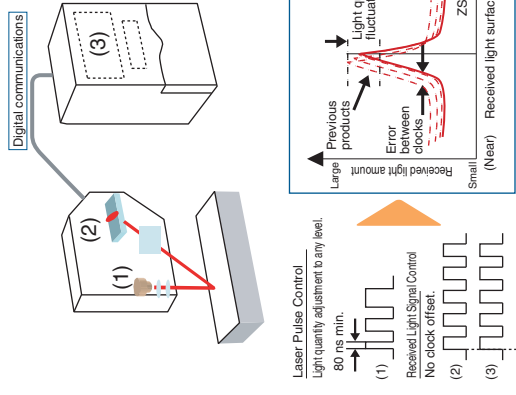

High-speed digital communications (LVDS) used between Sensor and Controller.

Image signal stabilizes because the clock error between the control signal from the Controller and the light reception device disappears. Optimum light quantity adjustment is possible with laser power algorithms that can be adjusted to any level, which facilitates super high resolution.

# Distance Sensors

## OMRON ZS-HLDC (Multitasking)

High performance with fully digital processing and multitasking functions. And filled with OMRON's leading-edge digital technology. Available in measurement performance.

### High-performance Sensing (Multitasking)

#### Simultaneous Measurement and Output of Up to 4 Features

- When simultaneous measurement of distance to glass, glass thickness, gap, etc., required in glass measurement applications

Setting example  
 ■ Task 1: Average  
 ■ Task 2: Thickness
- For simultaneous measurement of HDD surface deflection and distance to HDD surface

Setting example  
 ■ Task 1: Average, Average hold  
 ■ Task 2: Average, Point-to-point hold
- For detection of small recesses and protrusions in measurement location

Setting example  
 ■ Task 1: Step
- For measurement of steps in different locations with moving Sensor or workpiece

Setting example  
 ■ Task 1: Average  
 Self-down trigger  
 Average hold  
 With delay  
 ■ Task 2: Average  
 Average hold  
 With delay  
 ■ Task 3: Calculation (Task 2 - Task 1)

#### Simultaneous Control in 2 Systems of Data Confirmation and Analysis and Data Collection, Control, and Changeovers

**Control Using CompoWay/F\***

**Data Confirmation and Analysis**

- Checks sensing screen.
- Checks measurement values.
- Logs measurement values.

**Control Using No-protocol Communications**

**Data collection, control, and changeovers**

- Gets measurement results.
- Resets to zero.
- Switches banks.

\* OMRON's unique communications protocol.

#### Improved Total Cycle Time with 1-second High-speed Bank Switching

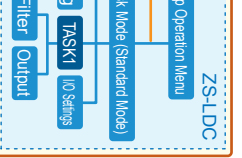

# Smart Sensor

Advanced technology is carried

## Can't Be Easier to Use (Common Functions)

High-performance Sensors

Information are displayed using visibility. Measurement received light amount can be customized to stand terminology.

Value displayed. Current, resolution, measurement information of a button.



Received light amount

### Set Sensing Directly

Patent Pending

In FUN (setting) Mode, setting menus are displayed on the 2 rows of the LCD. Easy-to-understand guidance simplifies setting the many display capabilities of the LCD. Function keys correspond to displayed menu items for intuitive setting of measurement conditions and other parameters. You can also easily switch between Japanese and English displays. Communication with the operator is better than ever before.

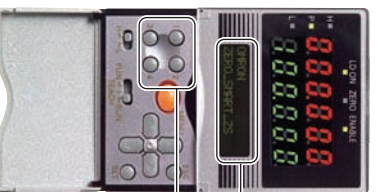

FUN (setting mode)

Direct setting with function keys.

### Connect directly to a PC using USB.

USB 2.0 and RS-232C provided as standard features. LVDS, a new-generation digital high-speed communications interface, is used between the Sensor Head and Controller, an industry first. If USB is used to connect to the computer, high-speed all digital measurement data transfer is possible.

Firmware can be updated easily using the SmartMonitor WarpEngine.

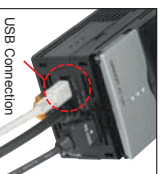

USB Connection



**ZS-LDC**  
Single Task Controller  
Simple Operation  
Reasonable Price

# Lineup 2D CMOS Low-end Displacement Sensors

packed into the smallest Sensor Heads in this class.

50S

- Smallest size in this class (65 × 65 mm)
- Uniform Sensor Head size
- Line/spot beam type
- Detects black rubber, mirror, and transparent workpieces

Active Lens  
ZS-LD50 uses  
precision  
ad lenses.

## ZS-LD20T/LD40T

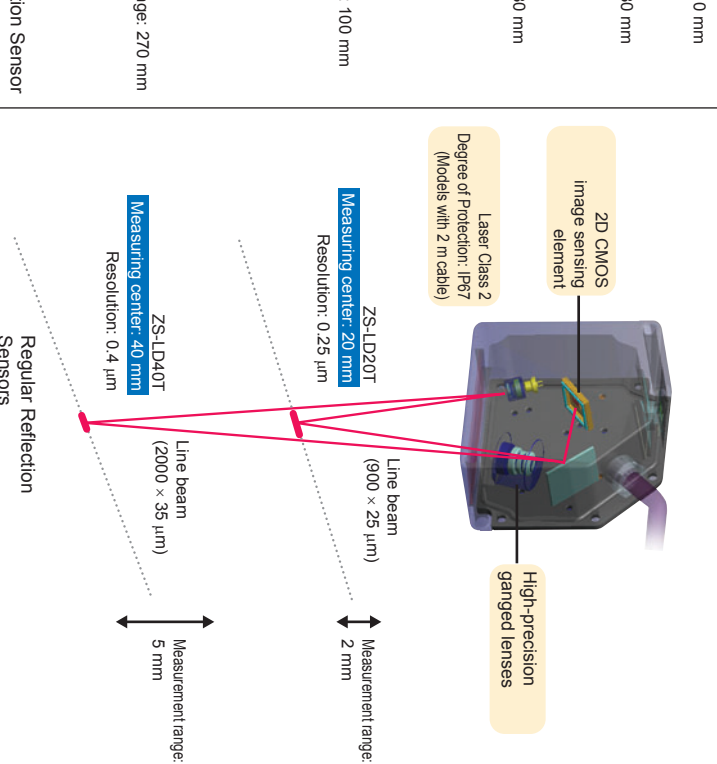

## ZS-LD20ST/LD50S

### Spot Beam Sensors

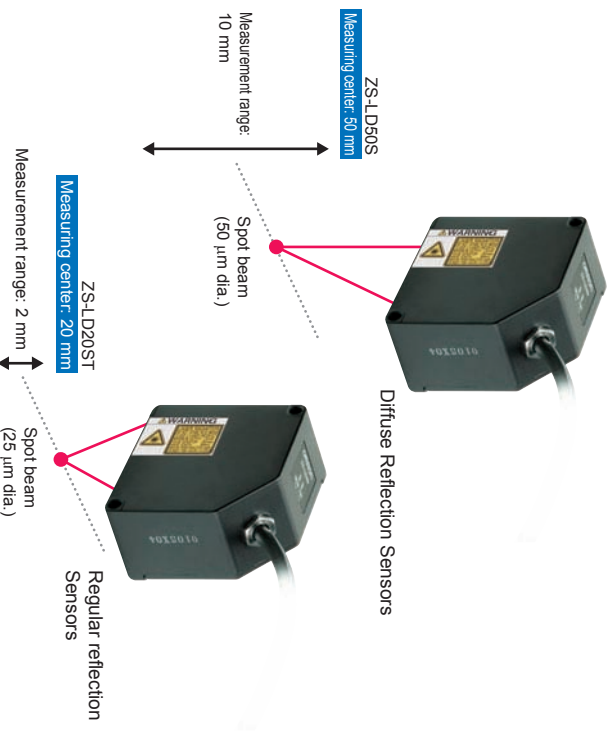

# Smart Sensor

Advanced technology is carried

## Line Beam Sensors for Emphasis on Stable Measurement

Line beams produce an averaging effect that is less likely to be affected by surface irregularities, creating stable measurements. Ideal for stable measurements that do not rely on the surface of the target workpiece.

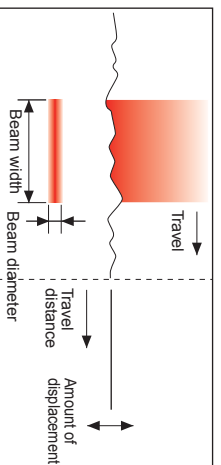

Line Beam sensors	ZS-LD20T	ZS-LD40T	ZS-LD50	ZS-LD80	ZS-LD130	ZS-LD200
Beam diameter	25 µm	35 µm	60 µm	60 µm	70 µm	100 µm
Beam width	0.9 mm	2 mm	0.9 mm	0.9 mm	0.6 mm	0.9 mm

## Spot Beam Sensors Ideal for Minute Workpieces and Shape Measurement

Spot beams produce measurements requiring minute shape repeatability while matching laser beam position with a minute target measurement area.

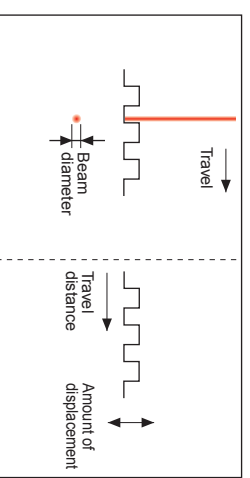

Spot Beam sensors	ZS-LD20ST	ZS-LD50S	ZS-LD350S
Beam width	25 µm dia.	50 µm dia.	240 µm dia.

Stable sensing of PCBs, resins, black resin could not be easily handled with

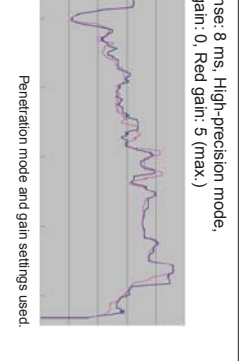
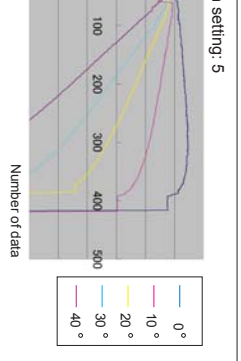

Coated, or colored glass on work tables.

Patterns on granite work tables to achieve

Measurements for Moving Glass

Course for glass 8 ms

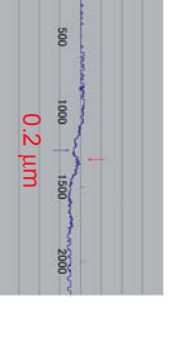

Coating glass with resist or sealer.

## Easy Sensing with an HMI That Couldn't Be Easier to Use

- Just select High-precision Mode to stably measure black rubber.
- Just select Penetration Mode to stably measure PCBs or black resin.

Set Sensing Directly

FUN (setting mode)



Direct setting with function keys.

## System Configuration

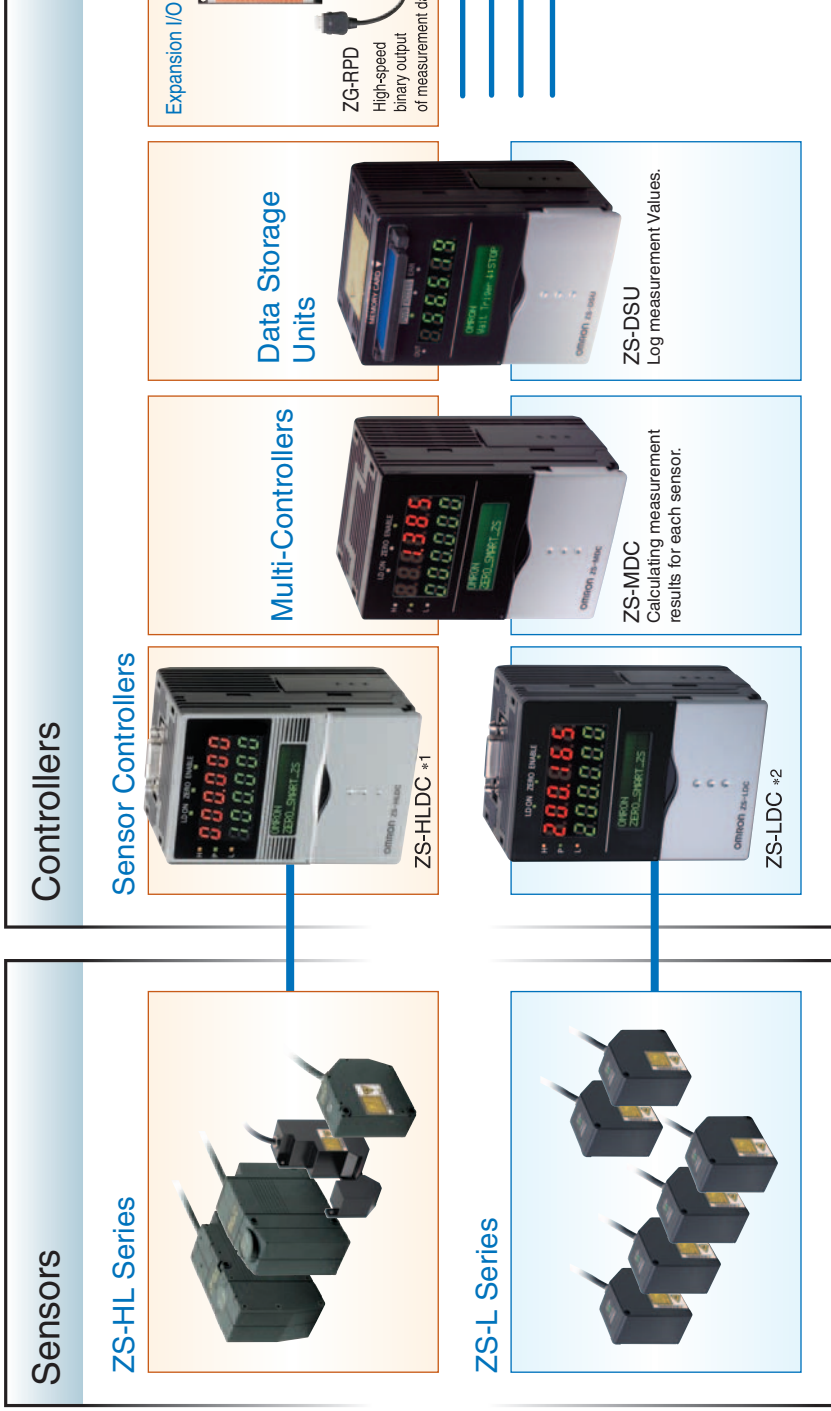

\*1: The ZS-HLDC can be connected to a ZS-H-L/L-series Sensor Head.  
 \*2: The ZS-LDC can be connected only to a ZS-L-series Sensor Head.

\*3: The ZG-RPD Expansion I/O Unit can be connected only to a ZS-H-L-series Sensor Controller.

### ZS-HL-series Long-distance Extension Cable

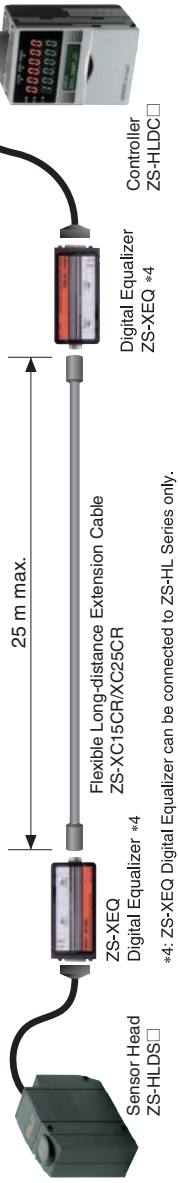

\*4: ZS-XEQ Digital Equalizer can be connected to ZS-HL Series only.

# Smart Sensor

Advanced technology is carried

## -MDC ormation Calculations

ontrollers and performs high-speed multiprocessing.

measurement, such as thickness, steps, and flatness  
 eatest high-speed bus in the industry. Digital processing  
 ssure exactly what is seen.  
 Sampling speed with 9 Controllers connected: 380 μs

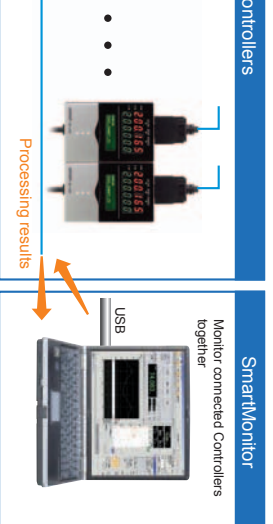

<p><b>Calculations</b></p> <p>Number of Sensor Controllers: 3 to 9</p> <p>Calculation: TASK1 = A - B TASK2 = A - C TASK3 = A - ...</p> <p>Individual judgments</p>	<p><b>Relative Step Calculations</b></p> <p>Calculating the difference between all points. Other points.</p> <p>Number of Sensor Controllers: 3 to 9</p> <p>Calculation: TASK1 = A - B TASK2 = B - C TASK3 = C - A</p> <p>Individual judgments</p>	<p><b>Twisting Calculations</b></p> <p>Calculating twisting between opposing sides.</p> <p>Number of Sensor Controllers: 3 to 9</p> <p>Calculation: TASK1 = A - B TASK2 = B - C TASK3 = C - A</p> <p>Individual judgments</p>
<p><b>Warp Calculations</b></p> <p>Calculating warping of selected sides</p> <p>Number of Sensor Controllers: 3</p> <p>Calculation: Task 1 = B - (A + C)/2</p>	<p><b>User-set Calculations</b></p> <p>Formulas can be flexibly set.</p> <p>[K + mX + nY]</p>	



Expansion Units

- Multi-calculations of Data
- Multipoint measurement
- High-speed data transfer

# S

## ZS-DSU

### ite Installed

Efficiently stores sensing data using a variety of logging functions.

High-speed, long term logging settings can be used to precisely process the required sensing data, which can be reliably and completely collected using USB and an all-digital bus.

Sensor setting data can also be stored.

Data for up to 128 banks can be stored and transferred to the Master Unit for changeovers.

- High-speed sampling rate: 150 μs max.
- Powerful support for logging data using various trigger functions.

Config-uration	Number of connectable Controllers	
	Connectable Controllers	10 max. (ZS-MDC: 1, ZS-HLDC/LDC: 9 max.) ZS-HLDC□, ZS-LDC□, ZS-MDC□
Perform-ance	Data resolution	32 bits
	Sampling rate	<ul style="list-style-type: none"> <li>• Shortest high-speed logging mode (One-shot Mode) *1</li> <li>• Long-term logging mode (Repeat Mode) *2</li> <li>• Sampling period: 10 ms to 1 h (at 1-ms intervals)</li> </ul>
Functions	Trigger functions	Start and end triggers can be set separately. External trigger/data trigger (self-trigger) Time triggers
	Other functions	<ul style="list-style-type: none"> <li>• External bank function</li> <li>• Alarm output function</li> <li>• Saved data format customization function</li> <li>• Time function (timestamps)</li> </ul>
Software (included)		<ul style="list-style-type: none"> <li>• CSV file generation Software</li> <li>• Excel macros for simple analysis (Equivalent to software provided with SmartMonitor Professional.)</li> </ul>

\*1) For One-shot Mode

- Connected to ZS-LDC

Number of channels	Min. sampling interval	Longest logging time
1	150 μs	10 min
2	200 μs	6.5 min
4	350 μs	5.5 min
9	650 μs	4.5 min

Typical examples

\*2) For Repeat Mode (Logging time depends on capacity of Memory Card.)

- Example for 64-MB Memory Card

Number of channels	Min. sampling interval	Longest logging time
1	10 ms	20 h
2	10 ms	10 h
4	10 ms	5 h
9	10 ms	2 h

Typical examples

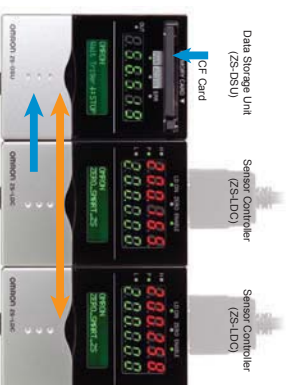

## Data Storage Unit

### ZS-DSU

- Connected to ZS-MDC

Number of channels	Min. sampling interval	Longest logging time
1	350 μs	20 min
2	400 μs	12 min
4	500 μs	8 min
9	700 μs	5 min

Typical examples

## Setting Software for ZS Series SmartMonitor V3 Prof

Use a Computer for Everything from Ideal ZS Settings to Powerful Support of Data Easy Settings Using USB.

### More Powerful Setting Support

The CMOS light reception image and the received light waveform can be displayed. The real power of the SmartMonitor is seen when measuring transparent objects and other workpieces that create multiple received light waveforms.

- Received Light Monitor

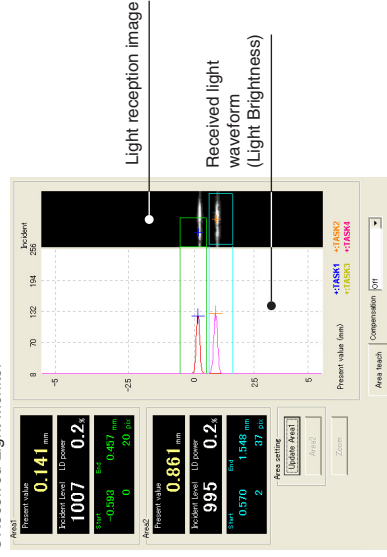

### Meets a wide range of logging needs.

Log measurement results at various times to leave judgment and inspection results.

The fastest sampling interval is 500  $\mu$ s (see note).

Note: Data may be skipped, depending on the computer system.

Use a computer that meets the recommended system requirements.

- Logging

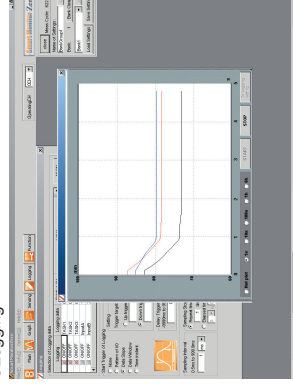

### High-speed simultaneous multichannel waveform graphs.

High-speed display: 2-ms interval at max. speed (see note); Simultaneous multichannel waveform display: Up to 9 waveforms can be displayed.

Note: Data may be skipped, depending on the computer system. Use a computer that meets the recommended system requirements.

- Multi-channel Waveform Display

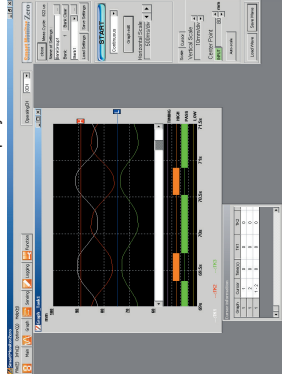

### Excel macro provided for simple analysis.

Data collected by logging can be processed with an Excel macro using filters, slope compensation, filter median transitions, differentiation, integration, and arithmetic functions and then used for nominal judgments and other determinations.

- Analysis

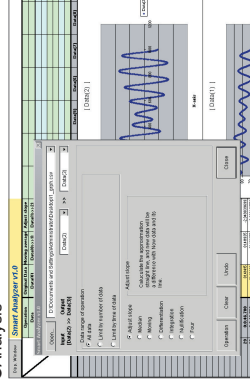

- Recommended SmartMonitor P  
 OS: Windows 7  
 Windows 7  
 CPU: Intel Pentium  
 Memory: 1 GB  
 Available hard disk  
 Display screen:  
 Note: If the recommended system requirements are not met, the software may be installed when using a multi-channel multi-channel SmartAnalyzer For Microsoft Excel  
 Microsoft Excel  
 - Window is registered in the USA and other countries  
 - Other companies' trademarks or registered trademarks are used without permission.

### Ordering Information Smart Sensor

#### ZS-HL-series Sensor Heads

Optical system	Sensing distance	Beam shape	Beam diameter	Resolution (see note)	Cable length	Model
Regular Reflective Models	20±1 mm	Line beam	1.0 mm x 20 µm	0.25 µm	2 m	ZS-HLDS2T 2M*
	25±2 mm	Line beam	2.2 mm x 45 µm	0.6 µm	0.5 m	ZS-HLDS2VT 2M
					0.5 m	ZS-HLDS2VT 0.5M
					2 m	ZS-HLDS2T 2M
50±5 mm	Line beam	1.0 mm x 30 µm	0.25 µm	0.5 m	ZS-HLDS5T 0.5M	
Diffuse Reflective Models	100±20 mm	Line beam	3.5 mm x 60 µm	1 µm	2 m	ZS-HLDS10 2M
	600±350 mm	Line beam	16 mm x 0.3 mm	8 µm	0.5 m	ZS-HLDS10 0.5M
					2 m	ZS-HLDS60 2M
					0.5 m	ZS-HLDS60 0.5M
1500±500 mm	Line beam	40 mm x 1.5 mm	500 µm	2 m	ZS-HLDS150 2M	
				0.5 m	ZS-HLDS150 0.5M	

Note : Refer to the table of ratings and specifications for details.

\* Orders will be accepted until the end of August 2019.

#### ZS-HL-series Sensor Heads (For Nozzle Gaps)

Optical system	Sensing distance	Beam shape	Beam diameter	Resolution (see note)	Cable length	Model
Regular Reflective Models	10±0.5 mm	Line beam	900 x 25 µm	0.25 µm	2 m	ZS-LD10GT 2M
	15±0.75 mm	Line beam	900 x 25 µm	0.25 µm	0.5 m	ZS-LD10GT 0.5M
					2 m	ZS-LD15GT 2M
					0.5 m	ZS-LD15GT 0.5M

Note : Refer to the table of ratings and specifications for details.

#### ZS-L-series Sensor Heads

Optical system	Sensing distance	Beam shape	Beam diameter	Resolution (see note)	Cable length	Model
Regular Reflective Models	20±1 mm	Line beam	900 x 25 µm	0.25 µm	2 m	ZS-LD20T 2M
		Spot beam	25 µm dia.	0.25 µm	0.5 m	ZS-LD20T 0.5M
	40±2.5 mm	Line beam	2000 x 35 µm	0.4 µm	0.5 m	ZS-LD20ST 0.5M
					4 m	ZS-LD40T 4M*
50±5 mm	Line beam	900 x 60 µm	0.8 µm	0.5 m	ZS-LD40T 0.5M	
				2 m	ZS-LD50 2M	
	Spot beam	50 µm dia.	0.8 µm	0.5 m	ZS-LD50 0.5M	
				2 m	ZS-LD50S 2M	
80±15 mm	Line beam	900 x 60 µm	2 µm	0.5 m	ZS-LD80 2M	
				1 m	ZS-LD80 1M	
	Line beam	600 x 70 µm	3 µm	0.5 m	ZS-LD80 0.5M	
				2 m	ZS-LD130 2M	
130±15 mm	Line beam	600 x 70 µm	3 µm	0.5 m	ZS-LD130 0.5M	
200±50 mm	Line beam	900 x 100 µm	5 µm	2 m	ZS-LD200 2M	
				0.5 m	ZS-LD200 0.5M	
	Spot beam	240 µm dia.	20 µm	2 m	ZS-LD350S 2M	
				0.5 m	ZS-LD350S 0.5M	

Note : No. of samples to average: 128 when set to High-precision Mode.

\* Orders will be accepted until the end of August 2019.

#### ZS-HL-series Sensor Controllers

Shape	Supply voltage	Cont.
	24 VDC	NP PN

#### ZS-L-series Sensor Controllers

Shape	Supply voltage	Cont.
	24 VDC	NP PN

#### Multi-Controllers

Shape	Supply voltage	Cont.
	24 VDC	NP PN

#### Data Storage Units



Shape	Supply voltage	Cont.
	24 VDC	NP PN

## Accessories (Sold Separately)

### Controller Link Unit

Shape	Model
	ZS-XCN

Shape	Model
	ZS-XPM1
	ZS-XPM2

### RS-232C Cables

Connected to	Model	Qty
Personal computer (2 m)	ZS-XRS3	1
PLC/PT (2 m)	ZS-XPT3	1

### Extension Cables for Sensor Heads

Cable length	Model	Qty
1 m	ZS-XC1A	1
4 m	ZS-XC4A	1
5 m	ZS-XC5B (*1, *2)	1
8 m	ZS-XC8A	1
10 m	ZS-XC10B (*1)	1

\*1. Up to two ZS-XC10B Cables can be connected. (22 m max.)

\*2. A Robot Cable (ZS-XC5BR) is also available.

### Long Extension Cables for Sensor Heads (Used with a Digital Equalizer for ZS-HL Series)

Name	Model	Qty
Digital Equalizer (Relay)	ZS-XEQ	1
Extension Cable (long distance, flexible 15 m cable)	ZS-XC15CR	1
Extension Cable (long distance, flexible 25 m cable)	ZS-XC25CR	1
Digital Equalizer Connection Cable (0.2 m)	ZS-XC02D	1

### Logging Software

Name	Model
SmartMonitor Professional	ZS-SW11V3E

### Realtime Parallel Output

Shape

### CompoNet-compatible

Shape

### Memory Cards

Model
HMC-EF283
HMC-EF583

### Quick Reference for Extension Cable Connections

Model	Extension Cable		Sensor Head		Remarks
	Length	Bend resistant	ZS-LD□ ZS-HLDS2V	ZS-HLDS2/ -HLDS5/-HLDS10/ -HLDS60/-HLDS150	
ZS-XC1A	1m		<input type="radio"/>	<input type="radio"/>	
ZS-XC4A	4m		<input type="radio"/>	<input type="radio"/>	
ZS-XC8A	8m		<input type="radio"/>	<input type="radio"/>	
ZS-XC5B	5m		<input type="radio"/>	<input type="radio"/>	
ZS-XC10B	10m		<input type="radio"/>	<input type="radio"/>	
ZS-XC5BR	5m	<input type="radio"/>	<input type="radio"/>	<input type="radio"/>	Only one Extension Cable can be used.
ZS-XC15CR	15m	<input type="radio"/>	<input type="radio"/>	<input type="radio"/>	Up to two Extension Cables can be used. (The maximum length is 22 m.)
ZS-XC25CR	25m	<input type="radio"/>	<input type="radio"/>	<input type="radio"/>	A ZS-XEQ Digital Equalizer and ZS-XC02D Digital Equalizer Connecting Cable are required.

# Ratings and Specifications

## ZS-HL/L-series Sensor Controllers

Item	Model		ZS-HLDC11/LDC11
No. of samples to average	1, 2, 4, 8, 16, 32, 64, 128, 256, 512, 1,024, 2,048		
Number of mounted Sensors	1 per Sensor Controller		
External interface	Connection method	Serial I/O: connector, Other: pre-wired (Standard cable)	
	Serial I/O	USB 2.0 RS-232C	1 port, Full Speed (12 Mbps max.), MINI-F
	Output	Judgment output Linear output	HIGH/PASS/LOW 3 outputs NPN open collector, 30 VDC, 50 mA max., residual voltage 1.2 V max. 1 port, 115,200 bps max.
Inputs	Laser OFF, ZERO reset timing, RESET	ON: Short-circuited with 0 V terminal or 1.5 V or less OFF: Open (leakage current: 0.1 mA max.)	
		Functions	<p>Display: Measured value, threshold value, voltage/current, received light a</p> <p>Sensing: Mode, gain, measurement object, head installation</p> <p>Measurement point *1: Average, peak, bottom, thickness, step, and calculations</p> <p>Filter: Smooth, average, and differentiation</p> <p>Outputs: Scaling, various hold values, and zero reset</p> <p>I/O settings: Linear (focus/correction), judgments (hysteresis and timer), non-n</p> <p>System: Save, initialization, measurement information display, communica</p> <p>Task: ZS-HLDC□1: Single task or multitask (up to 4) ZS-LDC□1: Single task</p>
Status indicators	HIGH (orange), PASS (green), LOW (orange), LDON (green), ZERO (e		
Segment display	Main digital	8-segment red LED, 6 digits	
	Sub-digital	8-segment green LEDs, 6 digits	
LCD	16 digits x 2 rows, Color of characters: green, Resolution per cha		
Setting inputs	Setting keys	Direction keys (UP, DOWN, LEFT, and RIGHT), SET key, ESC key, MEN	
	Slide switch	Threshold switch (2 states: High/Low), mode switch (3 states: F	
Power supply voltage	21.6 V to 26.4 VDC (including ripple)		
Current consumption	0.5 A max. (when Sensor Head is connected)		
Ambient temperature	Operating: 0 to 50°C, Storage: -15 to +60°C (with no icing)		
Ambient humidity	Operating and storage: 35% to 85% (with no cond		
Degree of protection	IP20 (IEC60529)		
Materials	Case: Polycarbonate (PC)		
Cable length	2 m		
Weight	Approx. 280 g (excluding packing materials and ac		
Accessories	Ferrite core (1), instruction sheet		

\*1. Can be used with ZS-HLDC□1 when Multitask Mode selected.

\*2. Terminal block output is a function of the ZS-HLDC□1.

# Ratings and Specifications

## ZS-HL-series Sensor Heads

Item	Model	ZS-HLDS2T	ZS-HLDS2VT	ZS-HLDS5T	ZS-HLDS10	
Applicable Controllers						
ZS-HLDC series						
Optical system	Regular reflection	Diffuse reflection	Regular reflection	Diffuse reflection	Regular reflection	
Measuring center distance	20 mm	5.2 mm	25 mm	50 mm	44 mm	
Measuring range	±1 mm	±1 mm	±2 mm	±5 mm	±4 mm	
Light source	Visible semiconductor laser (wavelength: 650 nm, 1 mW max., JIS Class 2)					
Beam shape	Line beam					
Beam diameter *1	1.0 mm x 20 μm	2.2 mm x 45 μm	1.0 mm x 30 μm	3.5 mm x 60 μm	1	
Linearity *2	±0.05%FS.	±0.2%FS.	±0.1%FS.	±0.1%FS.	±0.07%FS. (2)	
Resolution *3	0.25 μm (No. of samples to average: 256)	0.6 μm (No. of samples to average: 128)	0.25 μm (No. of samples to average: 512)	1 μm (No. of samples to average: 64)	8 μm (No. of samples to average: 16) 40 μm (No. of samples to average: 4)	
Temperature characteristic *4	0.01%FS./°C	0.1%FS./°C	0.1%FS./°C	0.01%FS./°C	0.01%FS./°C	
Sampling cycle	110 μs (High-speed Mode), 500 μs (Standard Mode), 2.2 μs (High-precision Mode), 4.4 μs (High-precision Mode)					
LED Indicators	NEAR indicator	Flashes when the measuring center distance, and closer than the measuring center distance inside the measuring range or when the received light is outside the measuring range				
	FAR indicator	Flashes when the measuring center distance, and farther than the measuring center distance inside the measuring range or when the received light is outside the measuring range				
Operating ambient illumination	Illumination on received light surface: 3000 lx or less (incandescent light)					
Ambient temperature	Operating: 0 to 50°C, Storage: -15 to 60°C (with no icing or condensation)					
Ambient humidity	Operating and storage: 35% to 85% (with no condensation)					
Degree of protection *5	IP64	IP67	IP67	Cable length 0.5 m: IP66, cable length 2 m: IP67		
Materials	Case: Aluminum die-cast, Front cover: Glass					
Cable length	0.5 m, 2 m	2 m	2 m	Approx. 600 g	0.5 m, 2 m	
Weight	Approx. 350 g					
Accessories	Laser labels (1 each for JIS/EN, 3 for FDA), ferrite cores (4), insure locks (2), instruction sheet	Laser labels (1 each for JIS/EN), ferrite cores (2), insure locks (2), instruction sheet	Laser labels (1 each for JIS/EN, 3 for FDA), ferrite cores (4)			Laser labels (1 each for JIS/EN, 3 for FDA), ferrite cores (4)

\*1. Defined as 1/e<sup>2</sup> (13.5%) of the center optical intensity at the actual measuring center distance (effective value). The beam diameter is sometimes influenced by the ambient conditions of the workpiece, such as distance in high-precision mode when the number of samples to average is set to within the graph.  
 \*2. This is the error in the measured value with respect to an ideal straight line. Linearity may change according to the workpiece. The following options are available.  
 \*3. This is the peak-to-peak displacement conversion value in the displacement output at the measuring center distance in high-precision mode when the number of samples to average is set to within the graph. The maximum resolution at 250 mm is also shown for the ZS-HLDS60. The following options are available.

Model	Diffuse reflection	Mirror reflection
ZS-HLDS2T	SUS block	Glass
ZS-HLDS2VT	---	Glass
ZS-HLDS5T	White alumina ceramic	Glass
ZS-HLDS10	White alumina ceramic	---
ZS-HLDS60/HLDS150	White alumina ceramic	---

Model	Diffuse reflection	Mirror reflection
ZS-HLDS2T	SUS block	Glass
ZS-HLDS2VT	---	Glass
ZS-HLDS5T	White alumina ceramic	Glass
ZS-HLDS10	White alumina ceramic	Glass
ZS-HLDS60/HLDS150	White alumina ceramic	---

# ications

	ZS-LD20ST	ZS-LD40T	ZS-LD10GT	ZS-LD15GT
	ZS-HLDC/LDC Series			
reflection	Regular reflection 20 mm	Diffuse reflection 6.3 mm	Regular reflection 40 mm	Diffuse reflection 30 mm
3 mm	±1 mm	±1 mm	±2.5 mm	±2 mm
1 mm	Visible semiconductor laser (wavelength: 650 nm, 1 mW max., JIS Class 2)			
	Spot beam			Line beam
	25 µm dia.		2000 × 35 µm	Approx. 25 × 900 µm
	0.25 µm		±0.1% FS	
	0.04% FS/°C		0.4 µm	0.25 µm
			0.02% FS/°C	0.04% FS/°C
	110 µs (High-speed Mode), 500 µs (Standard Mode), 2.2 ms (High-precision Mode), 4.4 ms (High-sensitivity Mode)			
	Lights near the measuring center distance, and closer than the measuring center distance inside the measuring range.			
	Flashes when the measurement target is outside of the measuring range or when the received light amount is insufficient.			
	Lights near the measuring center distance, and farther than the measuring center distance inside the measuring range.			
	Flashes when the measuring target is outside of the measuring range or when the received light amount is insufficient.			
	Illumination on received light surface: 3000 lx or less (incandescent light)			
	Operating: 0 to 50°C, Storage: -15 to 60°C (with no icing or condensation)			
	Operating and storage: 35% to 85% (with no condensation)			
	Cable length 0.5 m: IP66, cable length 2 m: IP67			IP40
	Case: Aluminum die-cast, Front cover: Glass			
	0.5 m, 2 m			
	Approx. 350 g		Approx. 400 g	
	Insure locks (2), instruction sheet		Laser safety labels (1 each for JIS/EN), ferrite cores (2), insure locks (2)	

ing center distance (effective value). The beam diameter is sometimes influenced by the ambient conditions of the workpiece, such as leaked light from the main beam.  
The standard workpiece is white aluminum ceramics and glass in the regular reflection mode. Linearity may change according to the workpiece.  
output at the measuring center distance in high-precision mode when the number of samples to average is set to 128 and the measuring mode is set to the high-resolution mode.  
r reflection mode.  
or and workpiece are fixed by an aluminum jig. (Typical example)

# Smart Sensor

Advanced technology is carried

## ifications

ZS-LD50S	ZS-LD80	ZS-LD190	ZS-LD200	ZS-LD350S
ZS-HLDC/LDC Series				
Diffuse reflection	Regular reflection	Diffuse reflection	Regular reflection	Diffuse reflection
50 mm	47 mm	80 mm	78 mm	130 mm
±5 mm	±4 mm	±15 mm	±14 mm	±15 mm
Visible semiconductor laser (wavelength: 650 nm, 1 mW max., JIS Class 2)				
Spot beam	Line beam	Line beam	Line beam	Spot beam
50 μm dia.	900 × 60 μm	600 × 70 μm	900 × 100 μm	240 μm dia.
±0.1% FS	±0.1% FS	±0.25% FS	±0.1% FS	±0.1% FS
0.8 μm	2 μm	3 μm	5 μm	20 μm
0.02% FS/°C	0.01% FS/°C	0.02% FS/°C	0.02% FS/°C	0.04% FS/°C
110 μs (High-speed Mode), 500 μs (Standard Mode), 2.2 ms (High-precision Mode), 4.4 ms (High-sensitivity Mode)				
Lights near the measuring center distance, and closer than the measuring center distance inside the measuring range.				
Flashes when the measurement target is outside of the measuring range or when the received light amount is insufficient.				
Lights near the measuring center distance, and farther than the measuring center distance inside the measuring range.				
Flashes when the measurement target is outside of the measuring range or when the received light amount is insufficient.				
Flashes when the measuring center distance, and farther than the measuring center distance inside the measuring range.				
Flashes when the measurement target is outside of the measuring range or when the received light amount is insufficient.				
Operating: 0 to 50°C, Storage: -15 to 60°C (with no icing or condensation)				
Operating and storage: 35% to 85% (with no condensation)				
Cable length 0.5 m: IP66, cable length 2 m: IP67				
Case: Aluminum die-cast, Front cover: Glass				
0.5 m, 2 m				
Approx. 350g				
Laser labels (1 each for JIS/EN, 3 for FDA), ferrite cores (2), insure locks (2), instruction sheet				

center distance (effective value). The beam diameter is sometimes influenced by the ambient conditions of the workpiece, such as leaked light from the main beam. The standard workpiece is white aluminum ceramics and glass in the ZS-LD50/LD50S regular reflection mode. Linearity may change according to the workpiece.

Output at the measuring center distance in high-precision mode when the number of samples to average is set to 128 and the measuring mode is set to the high-resolution mode.

LD50S regular reflection mode.

and workpiece are fixed by an aluminum jig.

# cations

controllers. The following points, however, are different:

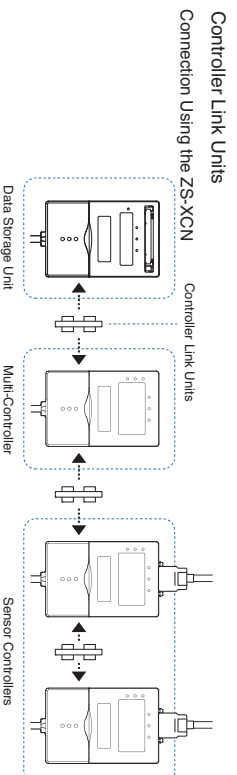

Model	ZS-DSU11	ZS-DSU41
	Cannot be connected	
	10 max. (ZS-MDC: 1, ZS-HLDC/LDC: 9 max.) *1	
	ZS-HLDC□□, ZS-LDC□□, ZS-MDC□□	
	Serial I/O: connector, Other: pre-wired (standard cable length: 2 m)	
	1 port, Full Speed (12 Mbps max.), MINI-B	
	1 port, 115,200 bps max.	
3 outputs: HIGH, PASS, and LOW; NPN open-collector, 30 VDC, 50 mA max., residual voltage: 1.2 V max.		3 outputs: HIGH, PASS, and LOW; PNP open-collector, 50 mA max., residual voltage: 1.2 V max.
ON: Short-circuited with 0 V terminal or 1.5 V or less; OFF: Open (leakage current: 0.1 mA max.)		ON: Short-circuited to supply voltage or within 1.5 V of supply voltage; OFF: Open (leakage current: 0.1 mA max.)
	32 bits	
	Start and stop triggers can be set separately; external triggers, data triggers (self-triggers), and time triggers	
	External banks, alarm outputs, saved data format customization, and clock	
	OUT (orange), PWR (green), ACCESS (orange), and ERR (red)	
	8-segment green LEDs, 6 digits	
	16 digits x 2 rows, Color of characters: green, Resolution per character: 5 x 8 pixel matrix	
	Direction keys (UP, DOWN, LEFT, and RIGHT), SET key, ESC key, MENU key, and function keys (1 to 4)	
	Threshold switch (2 states: High/Low), mode switch (3 states: FUN, TEACH, and RUN)	
	21.6 V to 26.4 VDC (including ripple)	
	0.5 A max.	
	Operating: 0 to 50°C, Storage: 0 to 60°C (with no icing or condensation)	
	Operating and storage: 35% to 85% (with no condensation)	
	IP20 (IEC60529)	
	Case: Polycarbonate (PC)	
	Approx. 280 g (excluding packing materials and accessories)	
	Ferrite core (1), Instruction sheet for Data Storage Unit, CSV File Converter for Data Storage Unit/Smart Analyzer Macro Edition	

# Smart Sensor

Advanced technology is carried

## Multi-Controllers

ZS-MDC□1

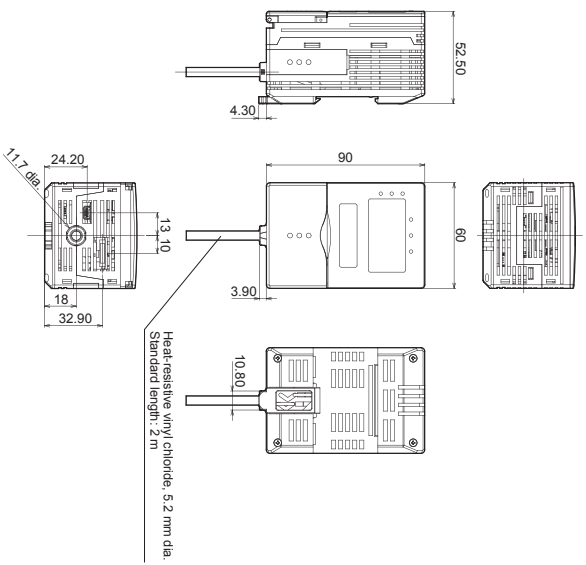

## Data Storage Units

ZS-DSU□1

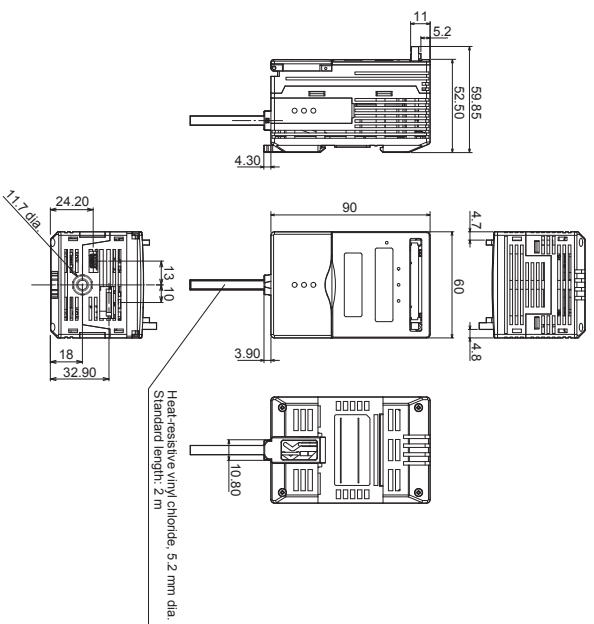

5 mm dia.

9 Holes

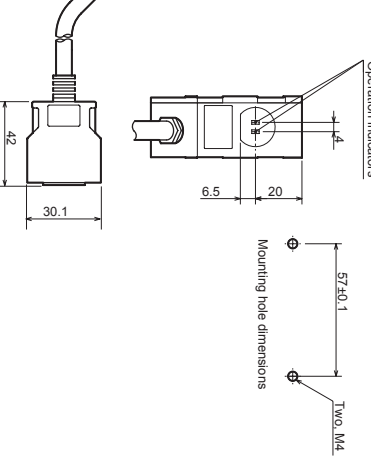

(Unit: mm)

### Sensor Heads

#### ZS-HLDS5T/HLDS10

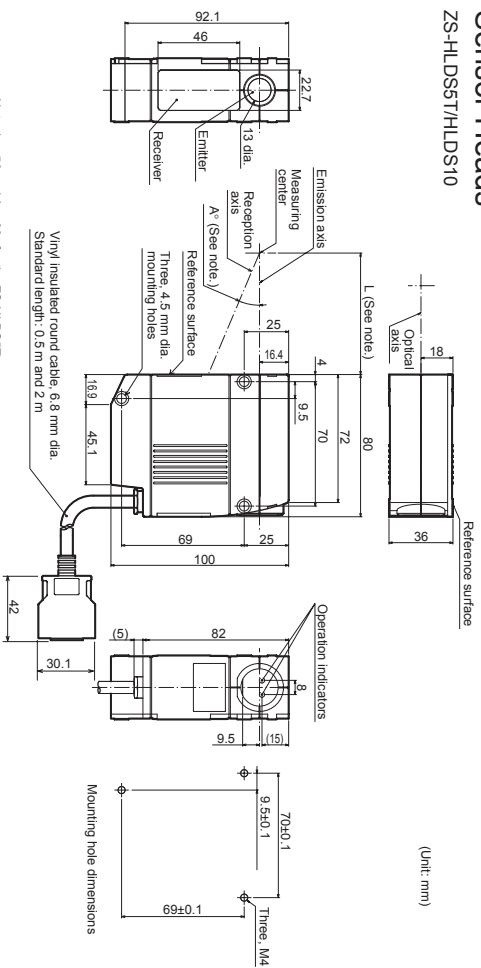

(Unit: mm)

Note: L = 50 and A = 30° for the ZS-HLDS5T.  
 L = 100 and A = 25° for the ZS-HLDS10.

Vinyl insulated round cable, 6.8 mm dia.  
 Standard length: 0.9 m and 2 m

(Unit: mm)

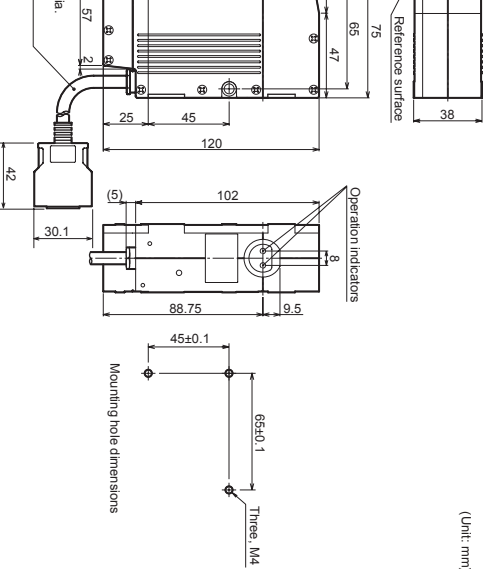

(Unit: mm)









unsuitable models. Please read the manual carefully for information that the user must  
take into consideration on warranty, limitations of liability, and precautions.

**Authorized Company**

**Authorized Distributor:**

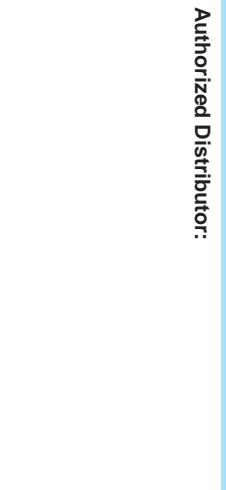



**OMRON ELECTRONICS LLC**  
10000 West Drive Schaumburg,  
Illinois 60196, U.S.A.  
Tel: 630-7900/Fax: (1) 847-843-7787

**OMRON (SHANGHAI) CO., LTD.**  
Bank of China Tower,  
Zhong Road,  
Pudong Area, Shanghai, 200120, China  
Tel: 86-21-222221/Fax: (86) 21-5037-2200



© OMRON Corporation 2009 All Rights Reserved.  
In the interest of product improvement,  
specifications are subject to change without notice.  
CSM\_5\_6\_0619 Printed in Japan  
Cat. No. E375-E1-02

## Looking for pricing, stock, or lifecycle information?

Click below to explore more details on WIN SOURCE:

-  [View ZS-HLDS60 0.5M on WIN SOURCE](#)
-  [Omron Information](#)

## Optimize Your Supply Chain with WIN SOURCE Solutions

-  Global Sourcing Solution
-  Obsolete Management
-  Cost Control Management
-  Shortage Management
-  Alternative Solution
-  Excess Inventory Management