



**THE DATASHEET OF  
NCX2220GU,115**



# NCX2220

## Low voltage comparator

Rev. 4 — 27 June 2012

Product data sheet

### 1. General description

---

The NCX2220 provides a dual low voltage low power comparator.

The NCX2220 has a very low supply current of 5  $\mu$ A per comparator and is guaranteed to operate at a low voltage of 1.3 V. It is fully operational up to 5.5 V which makes this device convenient for use in both 3.0 V and 5.0 V systems.

### 2. Features and benefits

---

- Wide supply voltage range from 1.3 V to 5.5 V (functional operating range)
- Rail-to-rail input/output performance
- Very low supply current of 5  $\mu$ A (typical) per comparator
- Very low-power consumption
- No phase inversion with overdriven input signals
- Internal hysteresis
- Propagation delay of 0.8  $\mu$ s (typical)
- ESD protection:
  - ◆ HBM JESD22-A114F Class 3A. Exceeds 2000 V
  - ◆ CDM JESD22-C101E exceeds 1000 V
- Multiple package options
- Specified from  $-40$  °C to  $+85$  °C

### 3. Applications

---

- Cellular telephones
- Alarm and security systems
- Personal Digital assistants



## 4. Ordering information

**Table 1. Ordering information**

Type number	Package			Version
	Temperature range	Name	Description	
NCX2220DP	-40 °C to +85 °C	TSSOP8	plastic thin shrink small outline package; 8 leads; body width 3 mm; lead length 0.5 mm	SOT505-2
NCX2220GU	-40 °C to +85 °C	HXSON8	plastic, thermal enhanced extremely thin small outline package; no leads; 8 terminals; body 1.35 × 1.7 × 0.5 mm	SOT972-2 <sup>[1]</sup>
NCX2220GT	-40 °C to +85 °C	XSON8	plastic extremely thin small outline package; no leads; 8 terminals; body 1 × 1.95 × 0.5 mm	SOT833-1
NCX2220GF	-40 °C to +85 °C	XSON8	extremely thin small outline package; no leads; 8 terminals; body 1.35 × 1 × 0.5 mm	SOT1089
NCX2220GM	-40 °C to +85 °C	XQFN8	plastic, extremely thin quad flat package; no leads; 8 terminals; body 1.6 × 1.6 × 0.5 mm	SOT902-2

[1] Lead pitch is 0.4 mm.

## 5. Marking

**Table 2. Marking codes**

Type number	Marking <sup>[1]</sup>
NCX2220DP	q2
NCX2220GU	q2
NCX2220GT	q2
NCX2220GF	q2
NCX2220GM	q2

[1] The pin 1 indicator is located on the lower left corner of the device, below the marking code.

## 6. Functional diagram

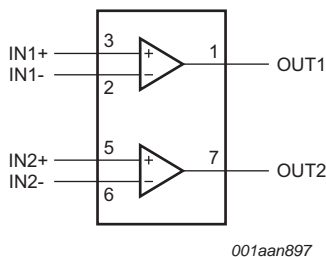

**Fig 1. Logic symbol**

## 7. Pinning information

### 7.1 Pinning

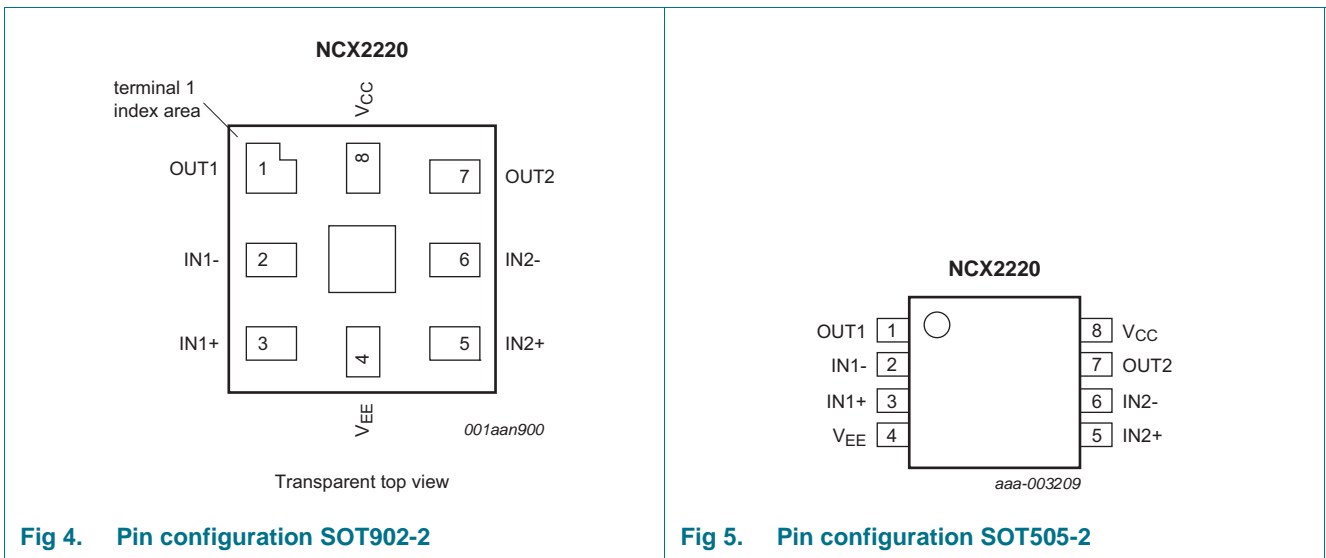
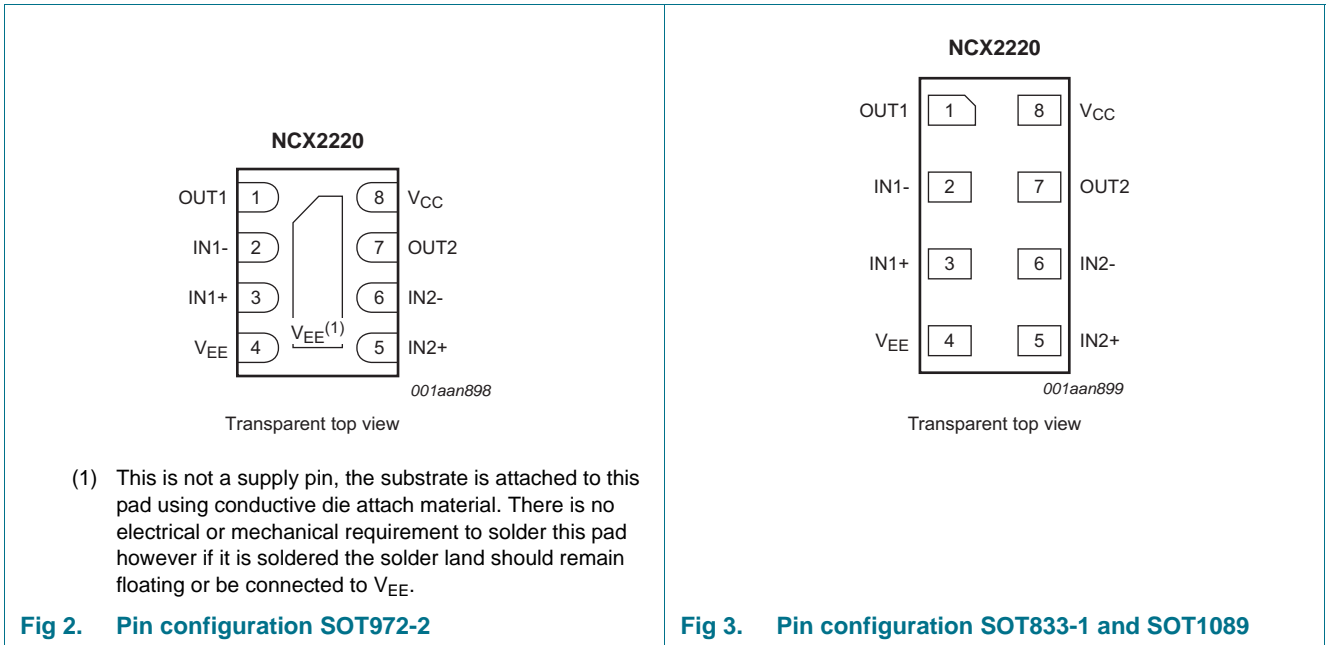

## 7.2 Pin description

**Table 3.** Pin description

Symbol	Pin	Description
OUT1	1	comparator output 1
IN1–	2	comparator input 1 (negative)
IN1+	3	comparator input 1 (positive)
V <sub>EE</sub>	4	supply voltage
IN2+	5	comparator input 2 (positive)
IN2–	6	comparator input 2 (negative)
OUT2	7	comparator output 2
V <sub>CC</sub>	8	supply voltage

## 8. Limiting values

**Table 4.** Limiting values

In accordance with the Absolute Maximum Rating System (IEC 60134). Voltages are referenced to V<sub>EE</sub>.

Symbol	Parameter	Conditions	Min	Max	Unit
V <sub>CC</sub>	supply voltage		-	7.0	V
V <sub>I</sub>	input voltage	IN1–, IN1+, IN2–, IN2+ inputs	–0.5	V <sub>CC</sub> + 0.5	V
t <sub>sc</sub>	short circuit duration time		[1] -	indefinite	s
T <sub>j(max)</sub>	maximum junction temperature		-	+150	°C
T <sub>stg</sub>	storage temperature		–65	+150	°C
P <sub>tot</sub>	total power dissipation	T <sub>amb</sub> = –40 °C to +85 °C	-	250	mW

[1] The maximum total power dissipation must not be exceeded.

## 9. Recommended operating conditions

**Table 5.** Recommended operating conditions

Symbol	Parameter	Conditions	Min	Typ	Max	Unit
V <sub>CC</sub>	supply voltage	V <sub>CC</sub> to V <sub>EE</sub>				
		full spec operating range	1.6	-	5.5	V
		functional operating range	1.3	-	5.5	V
V <sub>I</sub>	input voltage		V <sub>EE</sub>	-	V <sub>CC</sub>	V
T <sub>amb</sub>	ambient temperature		–40	-	+85	°C

## 10. Static characteristics

**Table 6. Static characteristics**

At recommended operating conditions.  $V_{CC} = 1.6\text{ V to }5.5\text{ V}$ ,  $V_{EE} = 0\text{ V}$ ;  $V_{CM} = 0.5V_{CC}$  unless otherwise specified.

Symbol	Parameter	Conditions	25 °C			−40 °C to +85 °C		Unit
			Min	Typ	Max	Min	Max	
$V_H$	hysteresis voltage		6	9	13	-	-	mV
		$V_{CC} = 1.3\text{ V}$	-	20	-	-	-	mV
$V_{I(\text{offset})}$	offset input voltage		[1] −30	0.5	+30	−30	+30	mV
		$V_{CC} = 1.3\text{ V}$	[1] -	3	-	-	-	mV
$V_{OH}$	HIGH-level output voltage	$I_O = -0.5\text{ mA}$ ; $V_{CC} = 1.3\text{ V}$	-	1.24	-	-	-	V
		$I_O = -0.5\text{ mA}$ ; $V_{CC} = 1.6\text{ V}$	-	1.55	-	1.35	-	V
		$I_O = -3\text{ mA}$ ; $V_{CC} = 3.0\text{ V}$	-	2.85	-	2.7	-	V
		$I_O = -5\text{ mA}$ ; $V_{CC} = 5.5\text{ V}$	-	5.33	-	5.2	-	V
$V_{OL}$	LOW-level output voltage	$I_O = 0.5\text{ mA}$ ; $V_{CC} = 1.3\text{ V}$	-	0.05	-	-	-	V
		$I_O = 0.5\text{ mA}$ ; $V_{CC} = 1.6\text{ V}$	-	0.04	-	-	0.25	V
		$I_O = 3\text{ mA}$ ; $V_{CC} = 3.0\text{ V}$	-	0.14	-	-	0.3	V
		$I_O = 5\text{ mA}$ ; $V_{CC} = 5.5\text{ V}$	-	0.20	-	-	0.3	V
$V_{CM}$	common-mode voltage	$V_{CC} = 1.3\text{ V to }5.5\text{ V}$	-	$V_{EE}$ to $V_{CC}$	-	-	-	V
$I_{OS}$	output short-circuit current	$V_{CC} = 5.5\text{ V}$ ; $V_O = V_{EE}$ or $V_{CC}$	-	68	-	-	-	mA
CMRR	common-mode rejection ratio	$\Delta V_{CM} = V_{CC}$	-	70	-	-	-	dB
PSRR	power supply rejection ratio	$\Delta V_{CC} = 1.95\text{ V}$	45	80	-	-	-	dB
$I_{IB}$	input bias current		-	1.0	-	-	-	pA
$I_{CC}$	supply current	per comparator	-	5.0	-	-	7.0	$\mu\text{A}$

[1] Differential input switching level is guaranteed at the minimum or maximum offset voltage, minus or plus half the maximum hysteresis voltage.

## 11. Dynamic characteristics

**Table 7. Dynamic characteristics**

Voltages are referenced to  $V_{EE}$  ( $V_{EE} = 0\text{ V}$ );  $V_{CC} = 1.6\text{ V to }5.5\text{ V}$ ;  $V_{CM} = 0.5V_{CC}$  unless otherwise specified.

Symbol	Parameter	Conditions	25 °C			Unit
			Min	Typ	Max	
$t_{pd}$	propagation delay	20 mV overdrive; $C_L = 15\text{ pF}$	[1] -	0.8	-	$\mu\text{s}$
$t_{THL}$	HIGH to LOW output transition time	$V_{CC} = 5.5\text{ V}$ ; $C_L = 50\text{ pF}$	[2] -	10	-	ns
$t_{TLH}$	LOW to HIGH output transition time	$V_{CC} = 5.5\text{ V}$ ; $C_L = 50\text{ pF}$	[2] -	10	-	ns

[1]  $t_{pd}$  is the same as  $t_{PLH}$  and  $t_{PHL}$ .

[2] Input signal: 1 kHz, squarewave signal with 10 ns edge rate.

**12. Graphs**

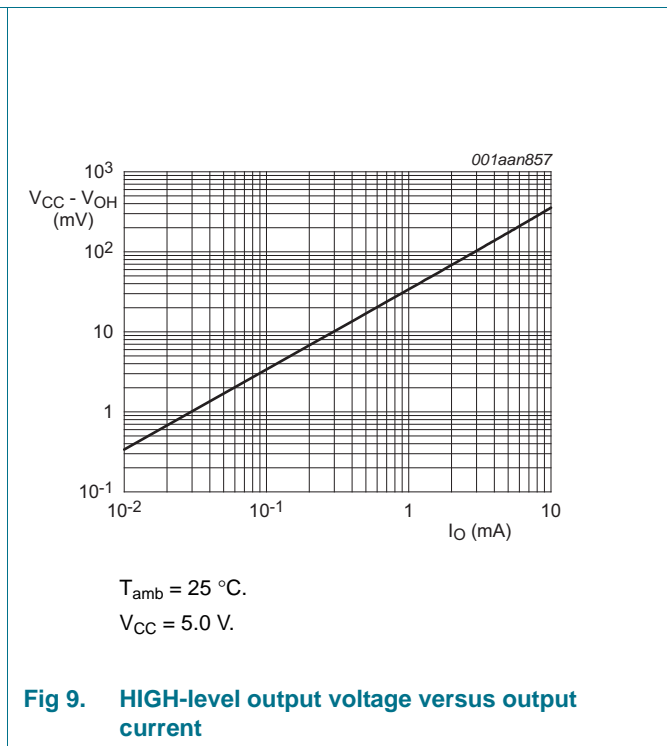
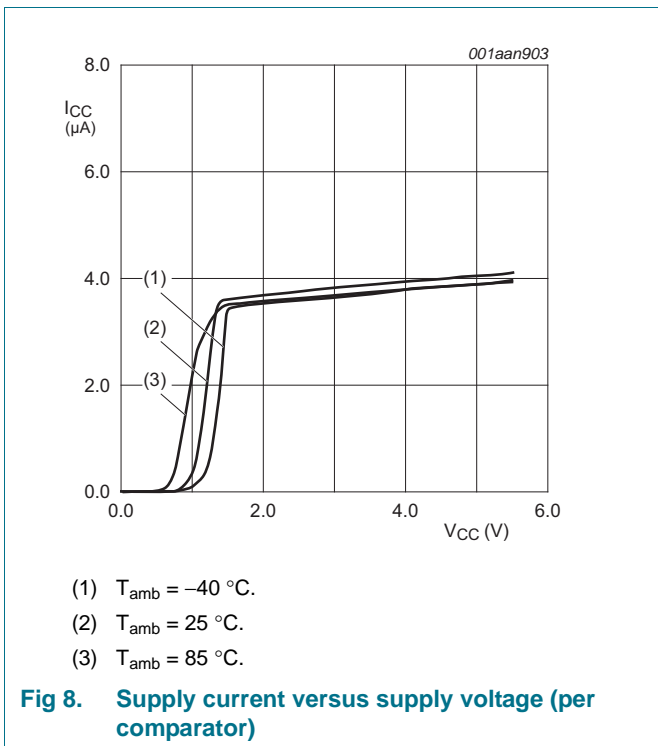
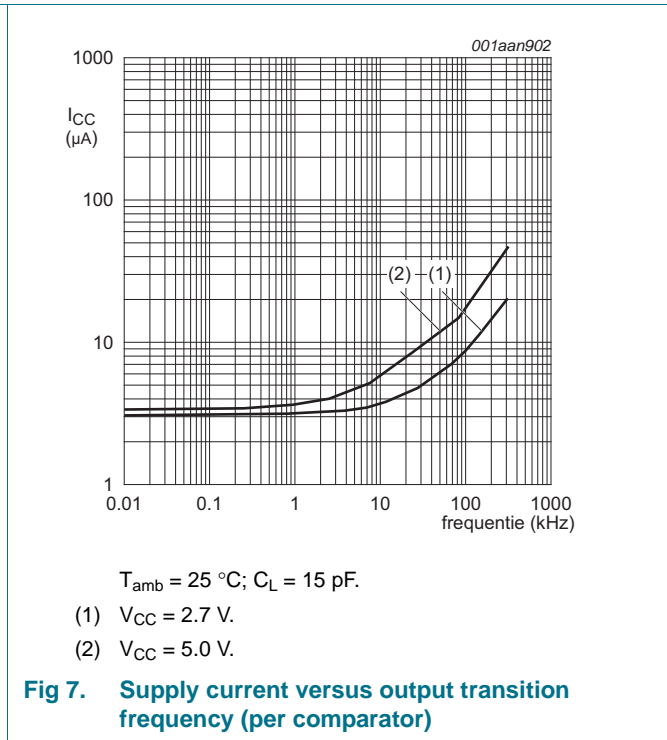
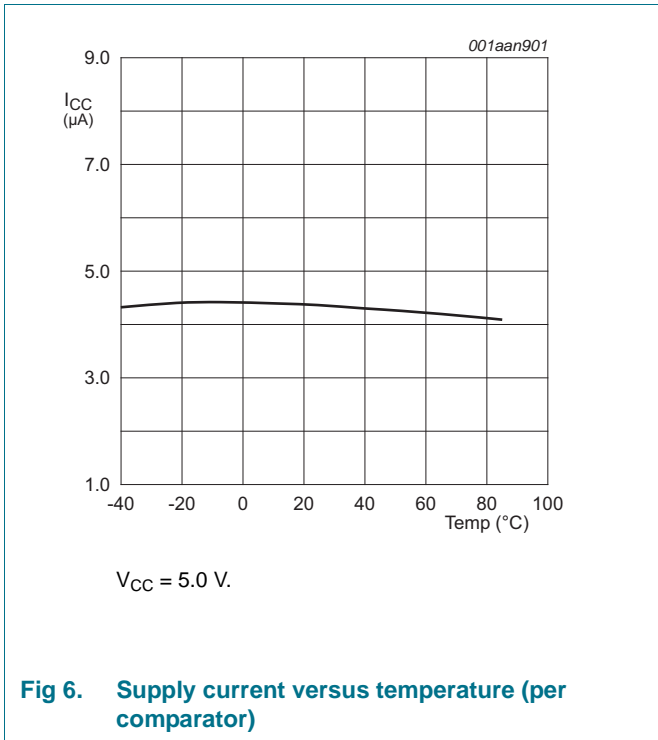

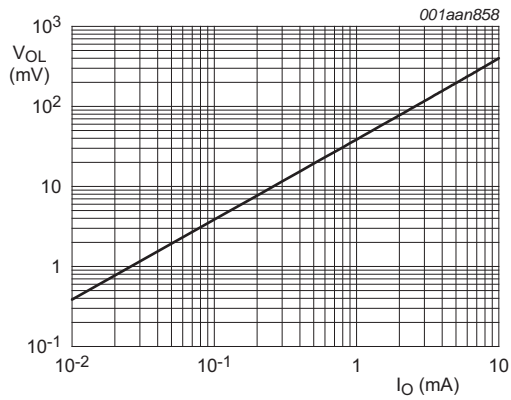

$T_{amb} = 25\text{ }^\circ\text{C}$ .  
 $V_{CC} = 5.0\text{ V}$ .

**Fig 10. LOW-level output voltage versus output current**

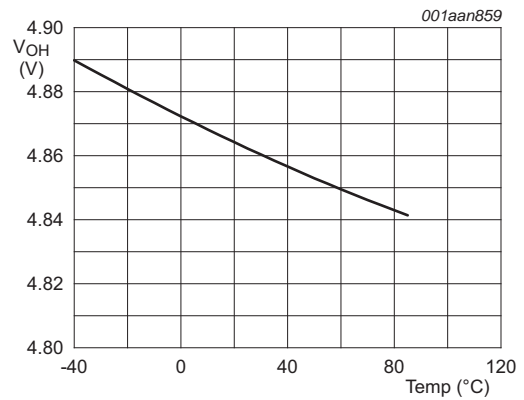

$I_O = -4.0\text{ mA}$ .  
 $V_{CC} = 5.0\text{ V}$ .

**Fig 11. HIGH-level output voltage versus temperature**

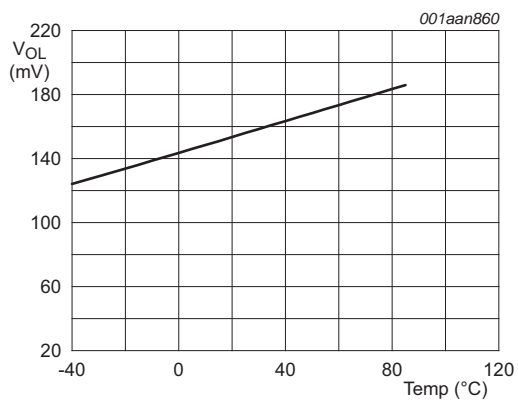

$I_O = 4.0\text{ mA}$ .  
 $V_{CC} = 5.0\text{ V}$ .

**Fig 12. LOW-level output voltage versus temperature**

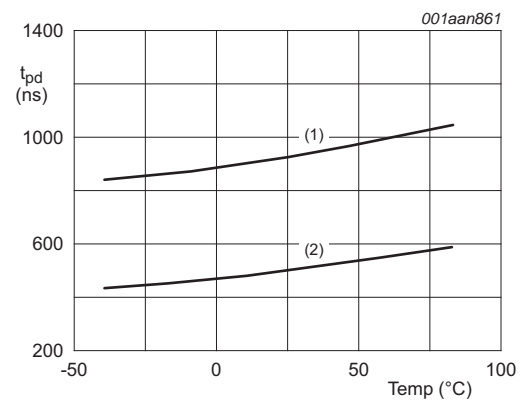

$V_{CC} = 5.0\text{ V}$ ; input overdrive = 50 mV.

- (1)  $t_{pLH}$ .
- (2)  $t_{pHL}$ .

**Fig 13. Propagation delay versus temperature**

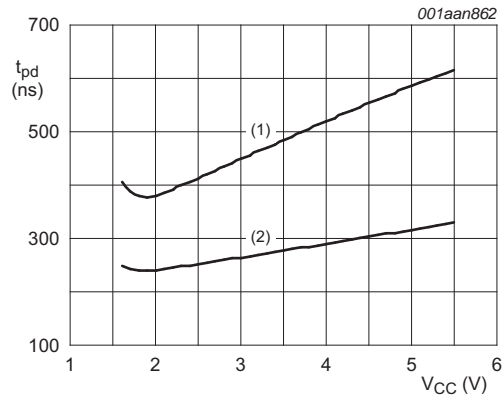

T<sub>amb</sub> = 25 °C; input overdrive = 100 mV.

(1) t<sub>PLH</sub>.

(2) t<sub>PHL</sub>.

**Fig 14. Propagation delay versus supply voltage.**

## 13. Application information

### 13.1 Operating description

The NCX2220 is a dual low voltage low power comparator. This device is designed for rail-to-rail input and output performance. This device consumes only 5  $\mu\text{A}$  per comparator of supply current while achieving a typical propagation delay of 0.8  $\mu\text{s}$  at a 20 mV input overdrive. This comparator is guaranteed to operate at a low voltage of 1.3 V up to 5.5 V. The common-mode input voltage range extends 0.1 V beyond the upper and lower rail without phase inversion or other adverse effects. This device has a typical internal hysteresis of 9.0 mV. This allows for greater noise immunity and clean output switching.

### 13.2 Output stage

The NCX2220 has a complementary P and N Channel output stage that has capability of driving a rail-to-rail output swing with a load ranging up to 5.0 mA. It is designed such that shoot-through current is minimized while switching. This feature eliminates the need for bypass capacitors under most circumstances. See [Figure 15](#)

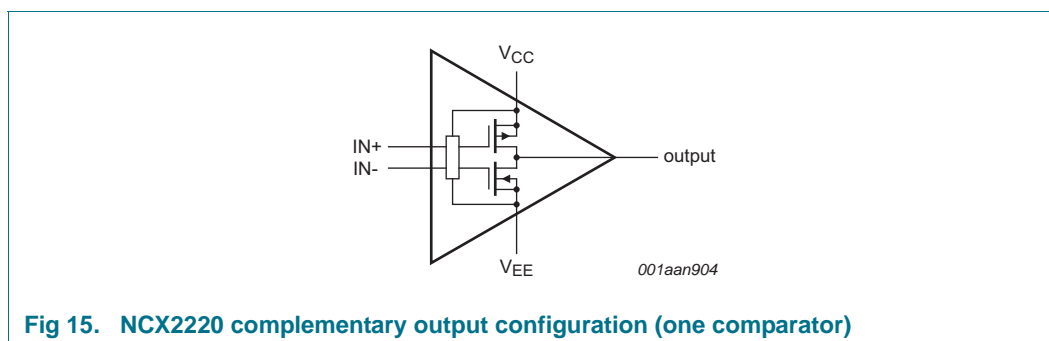
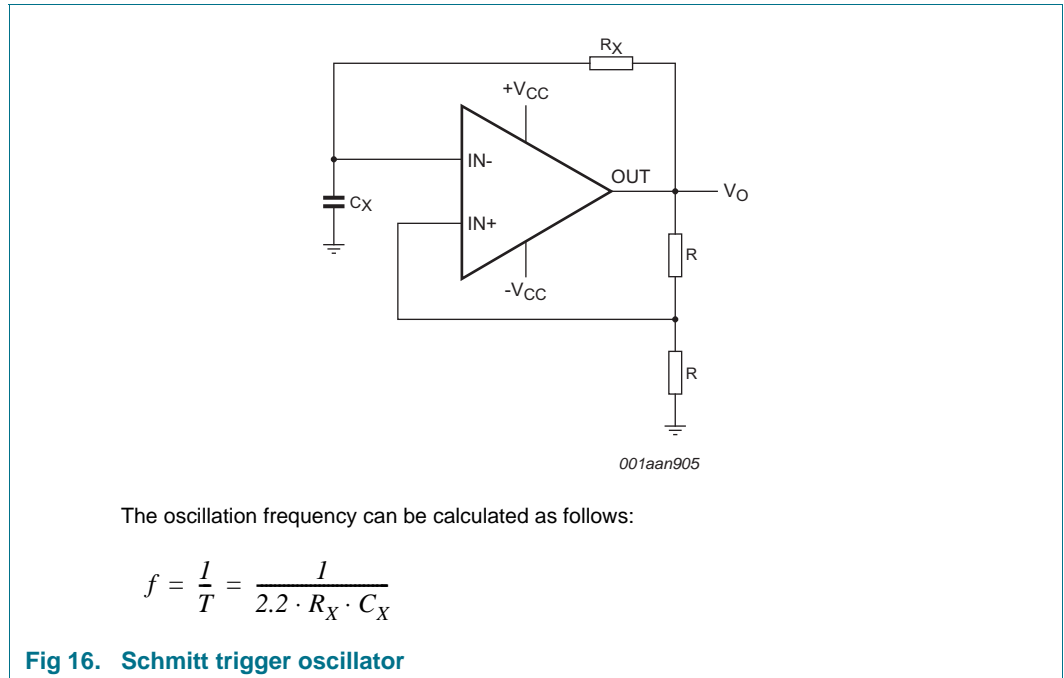

Fig 15. NCX2220 complementary output configuration (one comparator)

### 13.3 Schmitt trigger oscillator

Figure 16 shows the NCX2220 configured as a Schmitt trigger oscillator.



### 13.4 Zero-crossing detector

Figure 17 shows the NCX2220 configured as a zero-crossing detector.

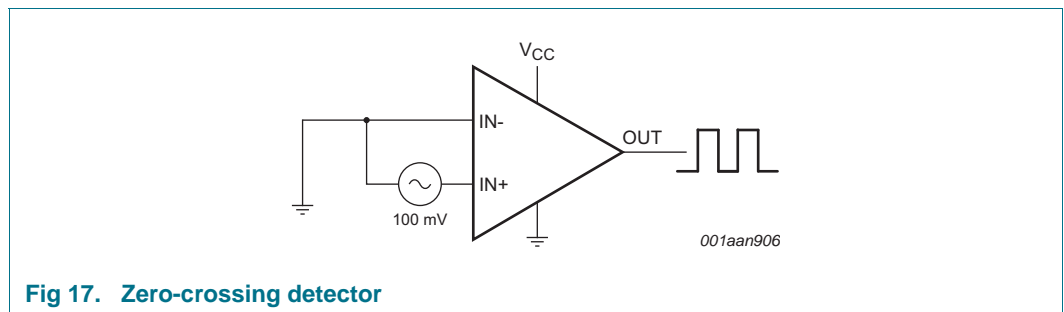

### 13.5 One-shot multivibrator

Figure 18 shows the NCX2220 configured as a one-shot multivibrator.

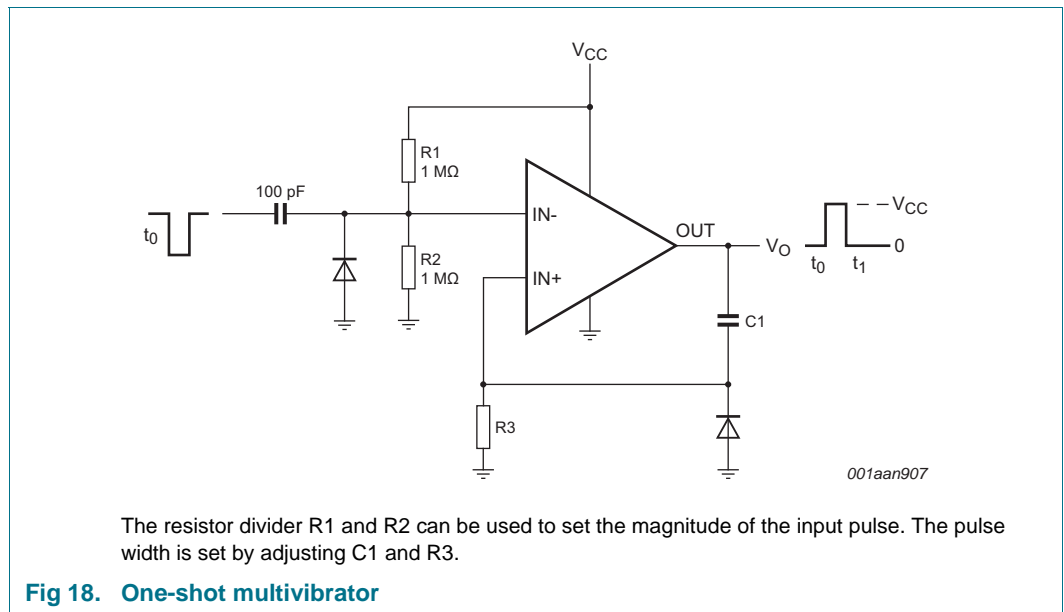

### 13.6 Logic level translator

Figure 19 shows the NCX2220 configured as a logic level translator.

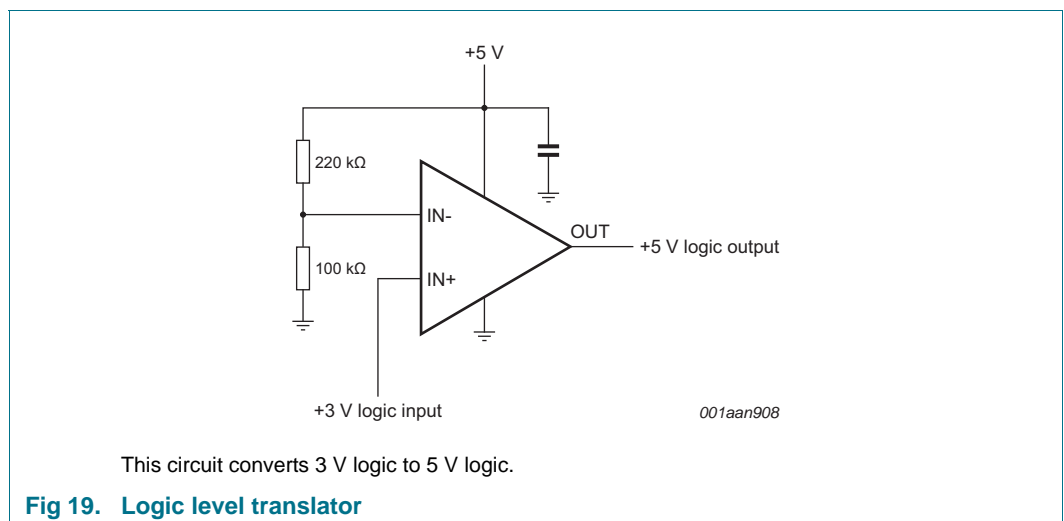

**14. Package outline**

**TSSOP8: plastic thin shrink small outline package; 8 leads; body width 3 mm; lead length 0.5 mm SOT505-2**

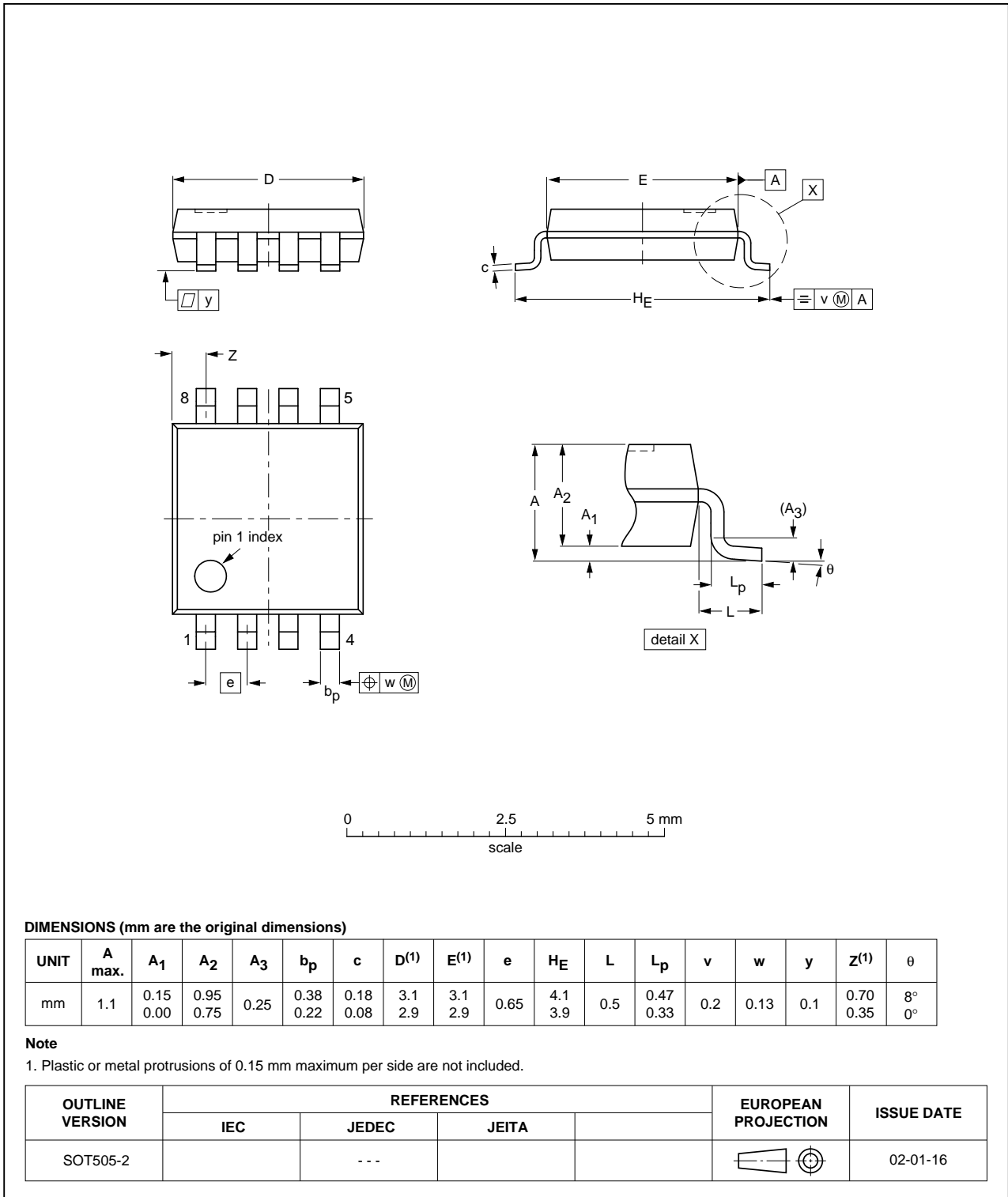

**Fig 20. Package outline SOT505-2 (TSSOP8)**

HXSON8: plastic, thermal enhanced extremely thin small outline package; no leads;  
8 terminals; body 1.35 x 1.7 x 0.5 mm

SOT972-2

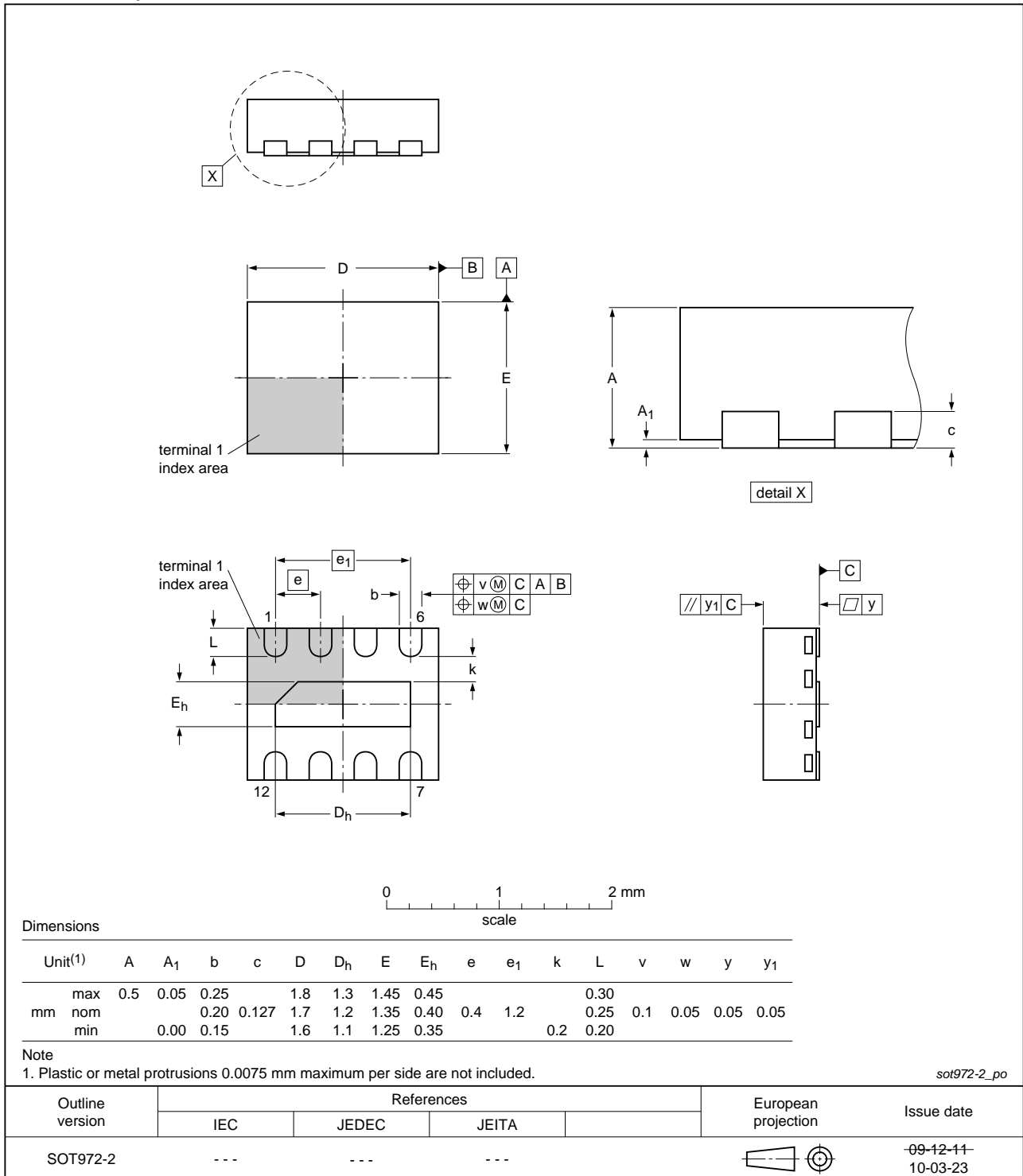

Fig 21. Package outline SOT972-2 (HXSON8)

XSON8: plastic extremely thin small outline package; no leads; 8 terminals; body 1 x 1.95 x 0.5 mm

SOT833-1

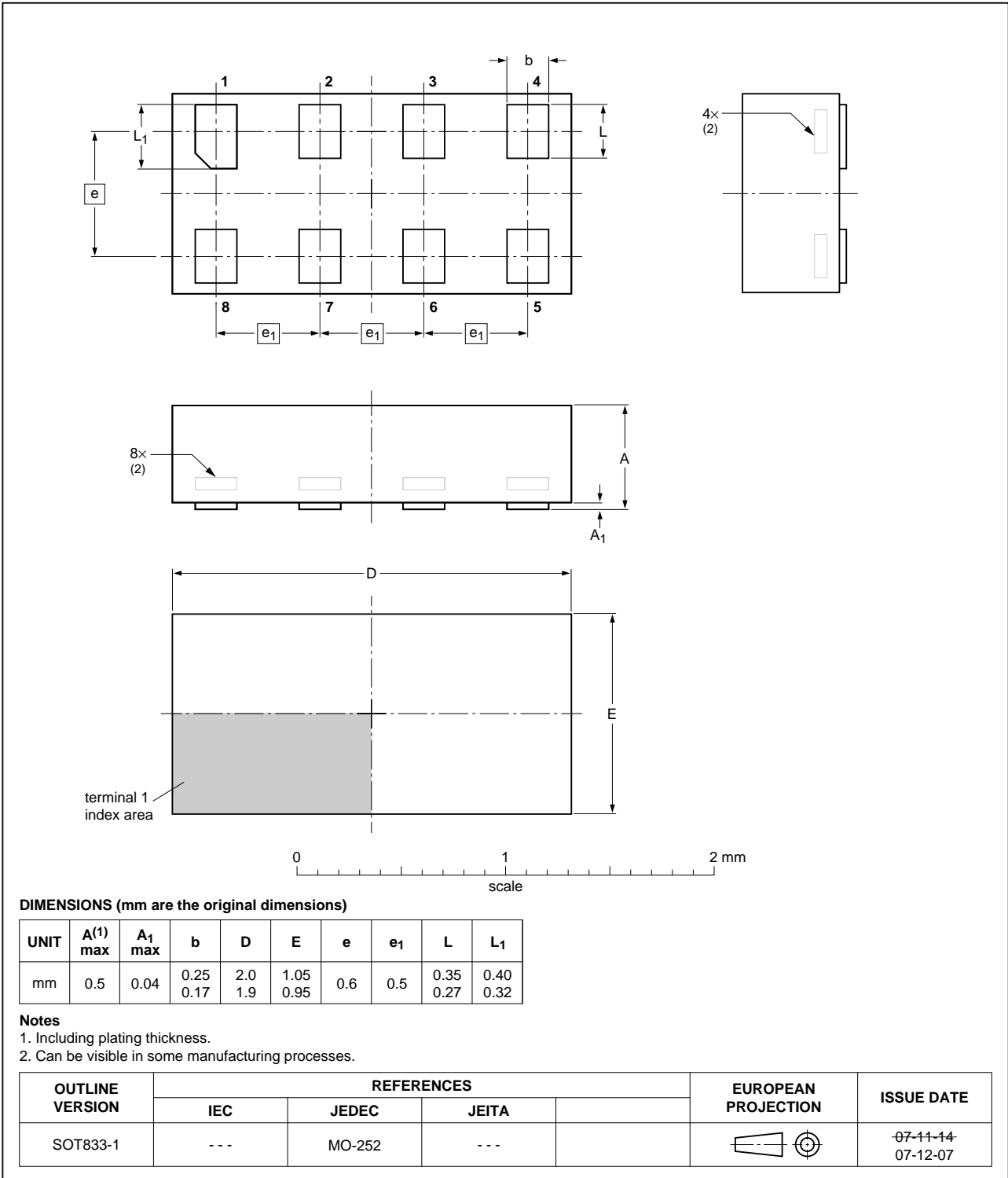

Fig 22. Package outline SOT833-1 (XSON8)

**XSON8: extremely thin small outline package; no leads;  
8 terminals; body 1.35 x 1 x 0.5 mm**

SOT1089

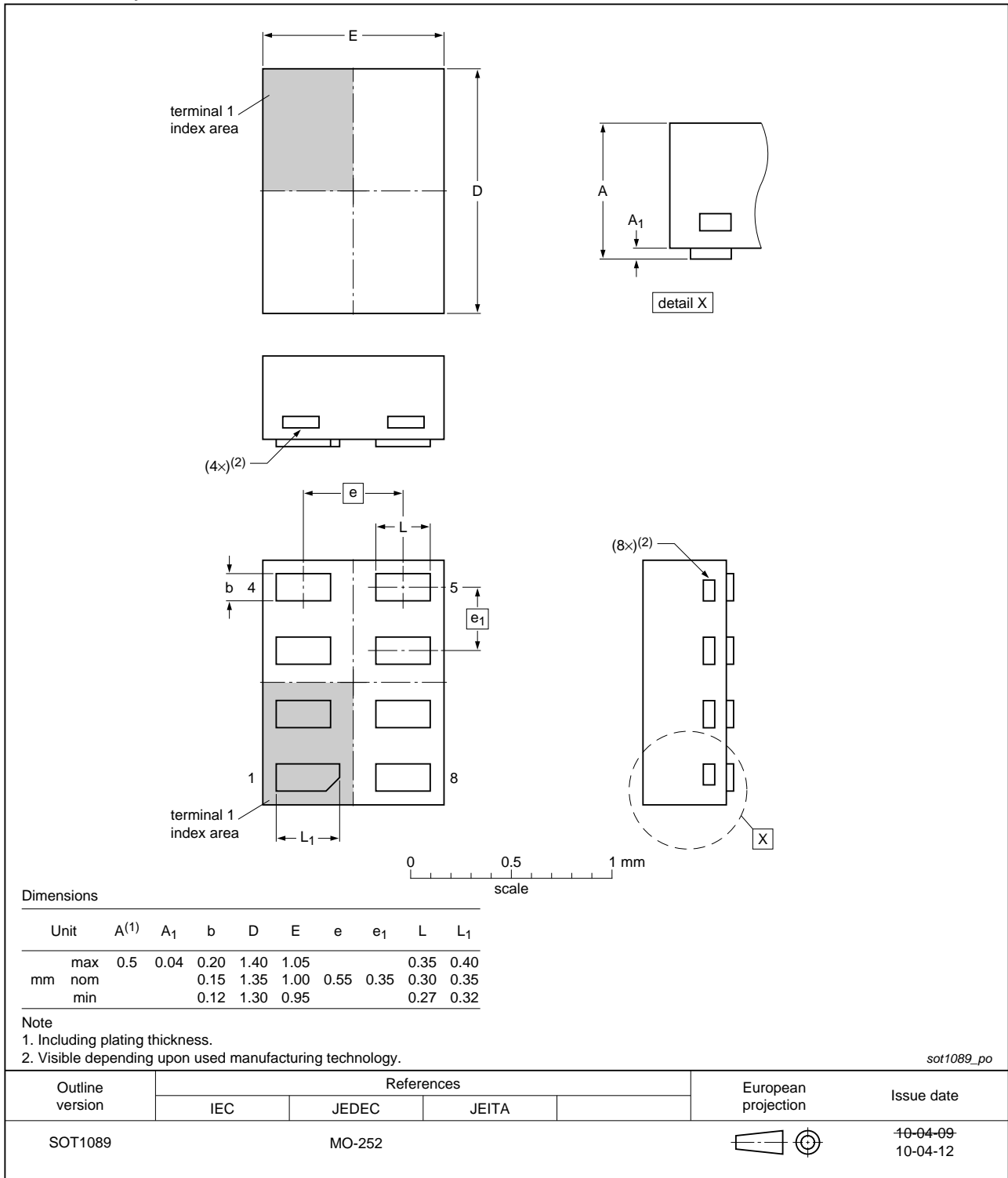

Fig 23. Package outline SOT1089 (XSON8)

XQFN8: plastic, extremely thin quad flat package; no leads;  
8 terminals; body 1.6 x 1.6 x 0.5 mm

SOT902-2

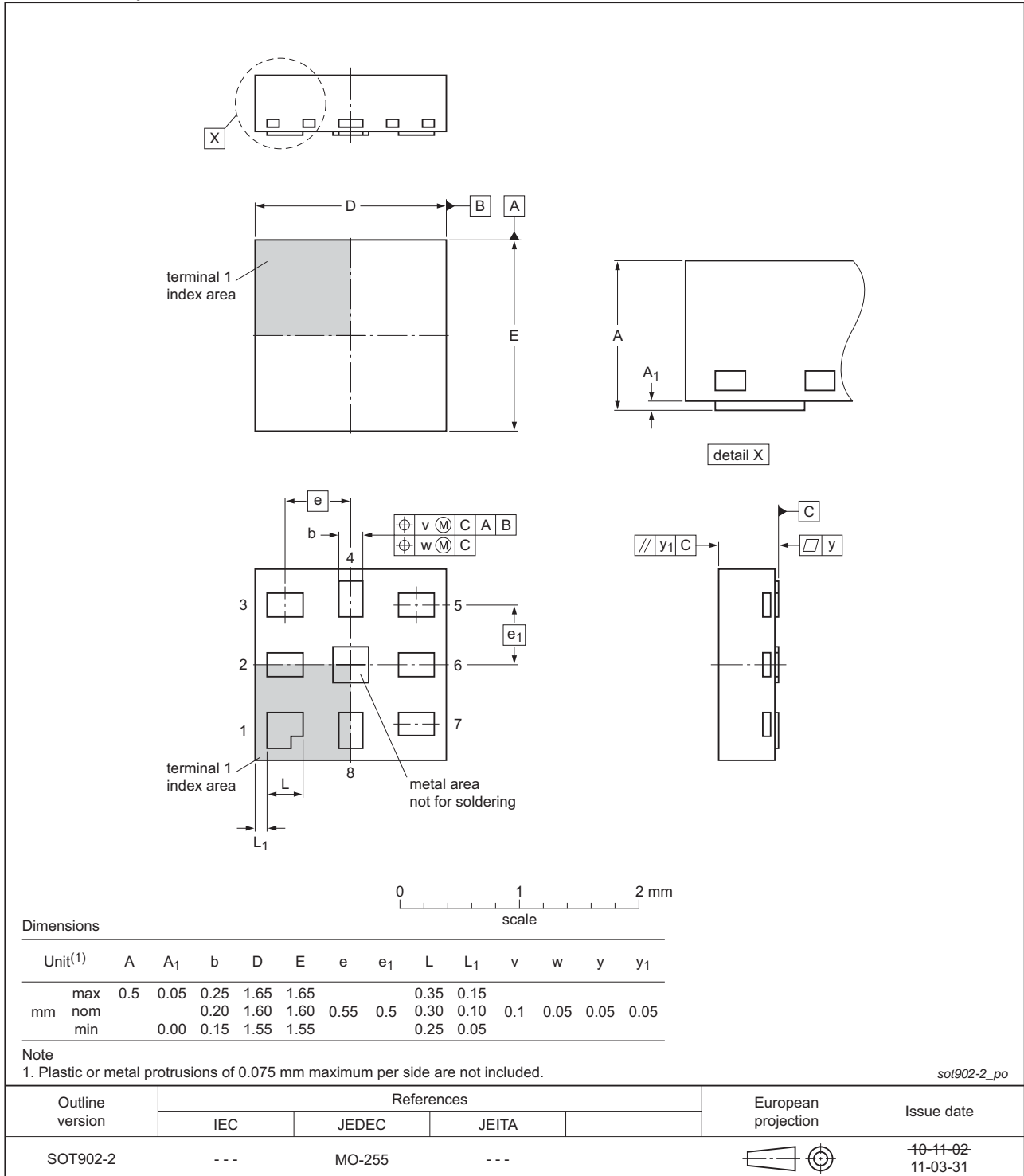

Fig 24. Package outline SOT902-2 (XQFN8)

## 15. Abbreviations

**Table 8. Abbreviations**

Acronym	Description
CDM	Charged Device Model
ESD	ElectroStatic Discharge
HBM	Human Body Model

## 16. Revision history

**Table 9. Revision history**

Document ID	Release date	Data sheet status	Change notice	Supersedes
NCX2220 v.4	20120627	Product data sheet	-	NCX2220 v.3
Modifications:	<ul style="list-style-type: none"><li>• For type number NCX2220GM the SOT code has changed to SOT902-2.</li><li>• NCX2220DP added.</li></ul>			
NCX2220 v.3	20111110	Product data sheet	-	NCX2220 v.2
Modifications:	<ul style="list-style-type: none"><li>• Legal pages updated.</li></ul>			
NCX2220 v.2	20111012	Product data sheet	-	NCX2220 v.1
NCX2220 v.1	20110405	Product data sheet	-	-

## 17. Legal information

### 17.1 Data sheet status

Document status <sup>[1][2]</sup>	Product status <sup>[3]</sup>	Definition
Objective [short] data sheet	Development	This document contains data from the objective specification for product development.
Preliminary [short] data sheet	Qualification	This document contains data from the preliminary specification.
Product [short] data sheet	Production	This document contains the product specification.

[1] Please consult the most recently issued document before initiating or completing a design.

[2] The term 'short data sheet' is explained in section "Definitions".

[3] The product status of device(s) described in this document may have changed since this document was published and may differ in case of multiple devices. The latest product status information is available on the Internet at URL <http://www.nxp.com>.

### 17.2 Definitions

**Draft** — The document is a draft version only. The content is still under internal review and subject to formal approval, which may result in modifications or additions. NXP Semiconductors does not give any representations or warranties as to the accuracy or completeness of information included herein and shall have no liability for the consequences of use of such information.

**Short data sheet** — A short data sheet is an extract from a full data sheet with the same product type number(s) and title. A short data sheet is intended for quick reference only and should not be relied upon to contain detailed and full information. For detailed and full information see the relevant full data sheet, which is available on request via the local NXP Semiconductors sales office. In case of any inconsistency or conflict with the short data sheet, the full data sheet shall prevail.

**Product specification** — The information and data provided in a Product data sheet shall define the specification of the product as agreed between NXP Semiconductors and its customer, unless NXP Semiconductors and customer have explicitly agreed otherwise in writing. In no event however, shall an agreement be valid in which the NXP Semiconductors product is deemed to offer functions and qualities beyond those described in the Product data sheet.

### 17.3 Disclaimers

**Limited warranty and liability** — Information in this document is believed to be accurate and reliable. However, NXP Semiconductors does not give any representations or warranties, expressed or implied, as to the accuracy or completeness of such information and shall have no liability for the consequences of use of such information. NXP Semiconductors takes no responsibility for the content in this document if provided by an information source outside of NXP Semiconductors.

In no event shall NXP Semiconductors be liable for any indirect, incidental, punitive, special or consequential damages (including - without limitation - lost profits, lost savings, business interruption, costs related to the removal or replacement of any products or rework charges) whether or not such damages are based on tort (including negligence), warranty, breach of contract or any other legal theory.

Notwithstanding any damages that customer might incur for any reason whatsoever, NXP Semiconductors' aggregate and cumulative liability towards customer for the products described herein shall be limited in accordance with the *Terms and conditions of commercial sale* of NXP Semiconductors.

**Right to make changes** — NXP Semiconductors reserves the right to make changes to information published in this document, including without limitation specifications and product descriptions, at any time and without notice. This document supersedes and replaces all information supplied prior to the publication hereof.

**Suitability for use** — NXP Semiconductors products are not designed, authorized or warranted to be suitable for use in life support, life-critical or safety-critical systems or equipment, nor in applications where failure or malfunction of an NXP Semiconductors product can reasonably be expected to result in personal injury, death or severe property or environmental damage. NXP Semiconductors and its suppliers accept no liability for inclusion and/or use of NXP Semiconductors products in such equipment or applications and therefore such inclusion and/or use is at the customer's own risk.

**Applications** — Applications that are described herein for any of these products are for illustrative purposes only. NXP Semiconductors makes no representation or warranty that such applications will be suitable for the specified use without further testing or modification.

Customers are responsible for the design and operation of their applications and products using NXP Semiconductors products, and NXP Semiconductors accepts no liability for any assistance with applications or customer product design. It is customer's sole responsibility to determine whether the NXP Semiconductors product is suitable and fit for the customer's applications and products planned, as well as for the planned application and use of customer's third party customer(s). Customers should provide appropriate design and operating safeguards to minimize the risks associated with their applications and products.

NXP Semiconductors does not accept any liability related to any default, damage, costs or problem which is based on any weakness or default in the customer's applications or products, or the application or use by customer's third party customer(s). Customer is responsible for doing all necessary testing for the customer's applications and products using NXP Semiconductors products in order to avoid a default of the applications and the products or of the application or use by customer's third party customer(s). NXP does not accept any liability in this respect.

**Limiting values** — Stress above one or more limiting values (as defined in the Absolute Maximum Ratings System of IEC 60134) will cause permanent damage to the device. Limiting values are stress ratings only and (proper) operation of the device at these or any other conditions above those given in the Recommended operating conditions section (if present) or the Characteristics sections of this document is not warranted. Constant or repeated exposure to limiting values will permanently and irreversibly affect the quality and reliability of the device.

**Terms and conditions of commercial sale** — NXP Semiconductors products are sold subject to the general terms and conditions of commercial sale, as published at <http://www.nxp.com/profile/terms>, unless otherwise agreed in a valid written individual agreement. In case an individual agreement is concluded only the terms and conditions of the respective agreement shall apply. NXP Semiconductors hereby expressly objects to applying the customer's general terms and conditions with regard to the purchase of NXP Semiconductors products by customer.

**No offer to sell or license** — Nothing in this document may be interpreted or construed as an offer to sell products that is open for acceptance or the grant, conveyance or implication of any license under any copyrights, patents or other industrial or intellectual property rights.

**Export control** — This document as well as the item(s) described herein may be subject to export control regulations. Export might require a prior authorization from competent authorities.

**Non-automotive qualified products** — Unless this data sheet expressly states that this specific NXP Semiconductors product is automotive qualified, the product is not suitable for automotive use. It is neither qualified nor tested in accordance with automotive testing or application requirements. NXP Semiconductors accepts no liability for inclusion and/or use of non-automotive qualified products in automotive equipment or applications.

In the event that customer uses the product for design-in and use in automotive applications to automotive specifications and standards, customer (a) shall use the product without NXP Semiconductors' warranty of the product for such automotive applications, use and specifications, and (b) whenever customer uses the product for automotive applications beyond

NXP Semiconductors' specifications such use shall be solely at customer's own risk, and (c) customer fully indemnifies NXP Semiconductors for any liability, damages or failed product claims resulting from customer design and use of the product for automotive applications beyond NXP Semiconductors' standard warranty and NXP Semiconductors' product specifications.

**Translations** — A non-English (translated) version of a document is for reference only. The English version shall prevail in case of any discrepancy between the translated and English versions.

## 17.4 Trademarks

Notice: All referenced brands, product names, service names and trademarks are the property of their respective owners.

## 18. Contact information

For more information, please visit: <http://www.nxp.com>

For sales office addresses, please send an email to: [salesaddresses@nxp.com](mailto:salesaddresses@nxp.com)

**19. Contents**

1 **General description** . . . . . 1

2 **Features and benefits** . . . . . 1

3 **Applications** . . . . . 1

4 **Ordering information** . . . . . 2

5 **Marking** . . . . . 2

6 **Functional diagram** . . . . . 2

7 **Pinning information** . . . . . 3

7.1 Pinning . . . . . 3

7.2 Pin description . . . . . 4

8 **Limiting values** . . . . . 4

9 **Recommended operating conditions** . . . . . 4

10 **Static characteristics** . . . . . 5

11 **Dynamic characteristics** . . . . . 5

12 **Graphs** . . . . . 6

13 **Application information** . . . . . 9

13.1 Operating description . . . . . 9

13.2 Output stage . . . . . 9

13.3 Schmitt trigger oscillator . . . . . 10

13.4 Zero-crossing detector . . . . . 10

13.5 One-shot multivibrator . . . . . 11

13.6 Logic level translator . . . . . 11

14 **Package outline** . . . . . 12

15 **Abbreviations** . . . . . 17

16 **Revision history** . . . . . 17

17 **Legal information** . . . . . 18

17.1 Data sheet status . . . . . 18

17.2 Definitions . . . . . 18

17.3 Disclaimers . . . . . 18

17.4 Trademarks . . . . . 19

18 **Contact information** . . . . . 19

19 **Contents** . . . . . 20

Please be aware that important notices concerning this document and the product(s) described herein, have been included in section 'Legal information'.

## Looking for pricing, stock, or lifecycle information?

Click below to explore more details on WIN SOURCE:

- ⊖ [View NCX2220GU,115 on WIN SOURCE](#)
- ⊖ [NXP / Nexperia Information](#)

## Optimize Your Supply Chain with WIN SOURCE Solutions

- ✓ Global Sourcing Solution
- ✓ Obsolete Management
- ✓ Cost Control Management
- ✓ Shortage Management
- ✓ Alternative Solution
- ✓ Excess Inventory Management