

8-Bit Serial-Input Latched Source Driver

Features

- High-Voltage, High-Current Outputs
- Output Transient Protection Diodes
- CMOS-, PMOS-, NMOS-, and TTL-Compatible Inputs
- 5 MHz Typical Data Input Rate
- Low-Power CMOS Latches

Applications

- Alphanumeric and Bar Graph Displays
- LED and Incandescent Displays
- Relay and Solenoid Drivers
- Other High-Power Loads

Package Type

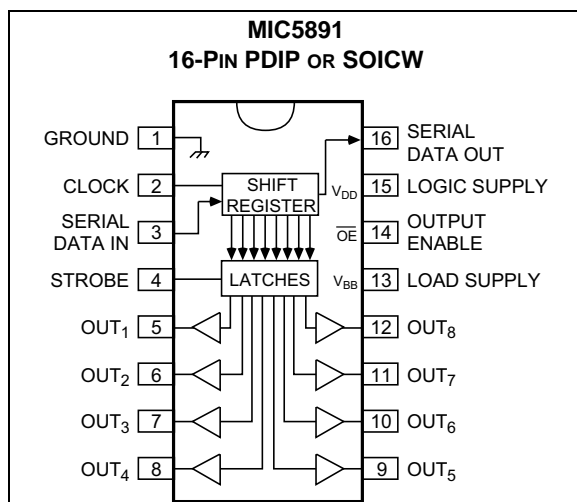

General Description

The MIC5891 latched driver is a high-voltage, high-current integrated circuit comprised of eight CMOS data latches, CMOS control circuitry for the common STROBE and OUTPUT ENABLE, and bipolar Darlington transistor drivers for each latch.

Bipolar/MOS construction provides extremely low power latches with maximum interface flexibility.

The MIC5891 will typically operate at 5 MHz with a 5V logic supply.

The CMOS inputs are compatible with standard CMOS, PMOS, and NMOS logic levels. TTL circuits may be used with appropriate pull-up resistors to ensure a proper logic-high input.

A CMOS serial data output allows additional drivers to be cascaded when more than 8 bits are required.

The MIC5891 has open-emitter outputs with suppression diodes for protection against inductive load transients. The output transistors are capable of sourcing 500 mA and will sustain at least 35V in the on-state.

Simultaneous operation of all drivers at maximum rated current requires a reduction in duty cycle due to package power limitations. Outputs may be paralleled for higher load current capability.

The MIC5891 is available in a 16-pin plastic DIP package (N) and 16-pin wide SOIC package (WM).

MIC5891

Functional Diagram

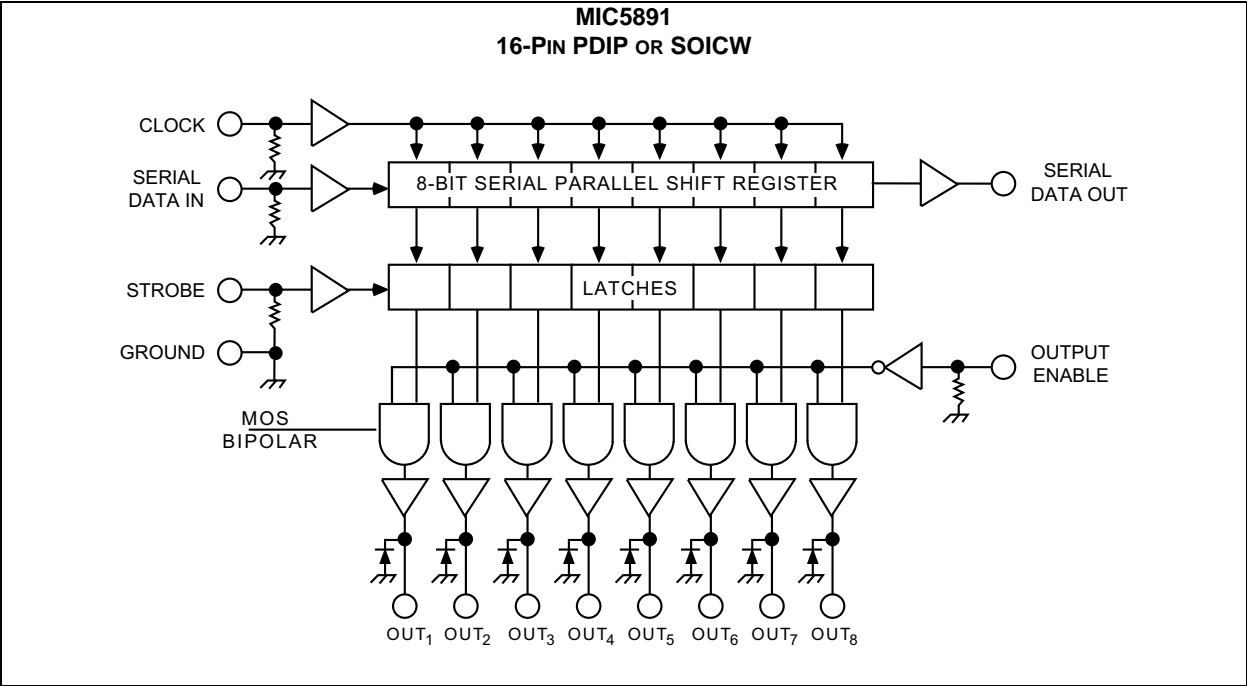

1.0 ELECTRICAL CHARACTERISTICS

Absolute Maximum Ratings † (Note 1, Note 2, Note 3)

Output Voltage (V_{OUT})	+50V
Logic Supply Voltage Range (V_{DD})	+4.5V to +15V
Load Supply Voltage Range (V_{BB})	+5.0V to +50V
Input Voltage Range (V_{IN})	-0.3V to ($V_{DD} + 0.3V$)
Continuous Collector Current (I_C)	500 mA
Package Power Dissipation	See Figure 2-1

† **Notice:** Stresses above those listed under “Absolute Maximum Ratings” may cause permanent damage to the device. This is a stress rating only and functional operation of the device at those or any other conditions above those indicated in the operational sections of this specification is not intended. Exposure to maximum rating conditions for extended periods may affect device reliability.

Note 1: $T_A = +25^\circ\text{C}$.

2: Derate at the rate of 20 mW/°C above $T_A = +25^\circ\text{C}$.

3: Microchip CMOS devices have input-static protection, but are susceptible to damage when exposed to extremely high static electrical charges.

TABLE 1-1: ALLOWABLE DUTY CYCLES

Number of Outputs ON at $I_{OUT} = -200\text{ mA}$	Maximum Allowable Duty Cycles at a T_A of:		
	+50°C	+60°C	+70°C
8	53%	47%	41%
7	60%	54%	48%
6	70%	64%	56%
5	83%	75%	67%
4	100%	94%	84%
3	100%	100%	100%
2	100%	100%	100%
1	100%	100%	100%

MIC5891

TABLE 1-2: ELECTRICAL CHARACTERISTICS

Electrical Characteristics: $V_{BB} = 50V$, $V_{DD} = 5V$ to $12V$; $T_A = 25^\circ C$, unless noted. (Note 1).						
Parameters	Sym.	Min.	Typ.	Max.	Units	Conditions
Output Leakage Current	I_{CEX}	—	—	-50	μA	$T_A = +25^\circ C$
		—	—	-100	μA	$T_A = +85^\circ C$
Output Saturation Voltage	$V_{CE(SAT)}$	—	—	2.3	V	$I_{OUT} = -100$ mA, $T_A = +85^\circ C$
		—	—	2.4	V	$I_{OUT} = -225$ mA, $T_A = +85^\circ C$
		—	—	2.5	V	$I_{OUT} = -350$ mA, $T_A = +85^\circ C$
Output Sustaining Voltage	$V_{CE(SUS)}$	35	—	—	V	$I_{OUT} = -350$ mA, $L = 2$ mH
Input Voltage	$V_{IN(1)}$ $V_{IN(0)}$	3.5	—	$V_{DD}+0.3$	V	$V_{DD} = 5.0V$
		10.5	—	$V_{DD}+0.3$	V	$V_{DD} = 12V$
		$V_{SS}-0.3$	—	0.8	V	$V_{DD} = 5.0V$ to $12V$
Input Current	$I_{IN(1)}$	—	—	120	μA	$V_{DD} = V_{IN} = 5.0V$
		—	—	240	μA	$V_{DD} = 12V$
Input Impedance	Z_{IN}	100	—	—	k Ω	$V_{DD} = 5.0V$
		50	—	—	k Ω	$V_{DD} = 12V$
Maximum Clock Frequency	f_c	3.3	—	—	MHz	—
Serial Data Output Resistance	R_{OUT}	—	—	20	k Ω	$V_{DD} = 5.0V$
		—	—	6.0	k Ω	$V_{DD} = 12V$
Turn-On Delay	t_{PLH}	—	—	2.0	μs	Output Enable to Output, $I_{OUT} = -350$ mA
Turn-Off Delay	t_{PHL}	—	—	10	μs	Output Enable to Output, $I_{OUT} = -350$ mA
Supply Current	I_{BB}	—	—	10	mA	All outputs on, all outputs open
		—	—	200	μA	All outputs off
	I_{DD}	—	—	100	μA	$V_{DD} = 5V$, all outputs off, inputs = 0V
		—	—	200	μA	$V_{DD} = 12V$, all outputs off, inputs = 0V
		—	—	1.0	mA	$V_{DD} = 5V$, one output on, inputs = 0V
Diode Leakage Current	I_H	—	—	50	μA	$T_A = +25^\circ C$; Max. V_{BB}
		—	—	100	μA	$T_A = +85^\circ C$; Max. V_{BB}
Diode Forward Voltage	V_F	—	—	2.0	V	$I_F = 350$ mA; V_{BB} open

Note 1: Specification for packaged product only.

2: Positive (negative) current is defined as going into (coming out of) the specified device pin.

3: Operation of these devices with standard TTL may require the use of appropriate pull-up resistors.

TEMPERATURE SPECIFICATIONS

Parameters	Sym.	Min.	Typ.	Max.	Units	Conditions
Temperature Ranges						
Operating Temperature Range	T_A	-40	—	+85	°C	Note 1
Storage Temperature Range	T_S	-65	—	+150	°C	—

Note 1: The maximum allowable power dissipation is a function of ambient temperature, the maximum allowable junction temperature and the thermal resistance from junction to air (i.e., T_A , T_J , θ_{JA}). Exceeding the maximum allowable power dissipation will cause the device operating junction temperature to exceed the maximum +125°C rating. Sustained junction temperatures above +125°C can impact the device reliability.

Typical Circuits

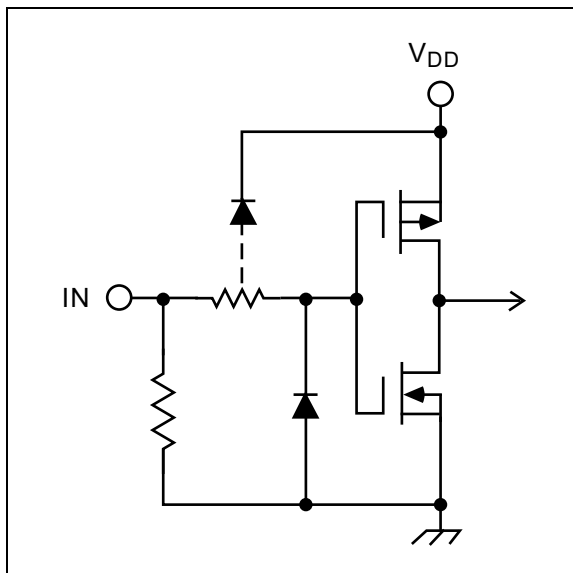

FIGURE 1-1: Typical Input Circuit

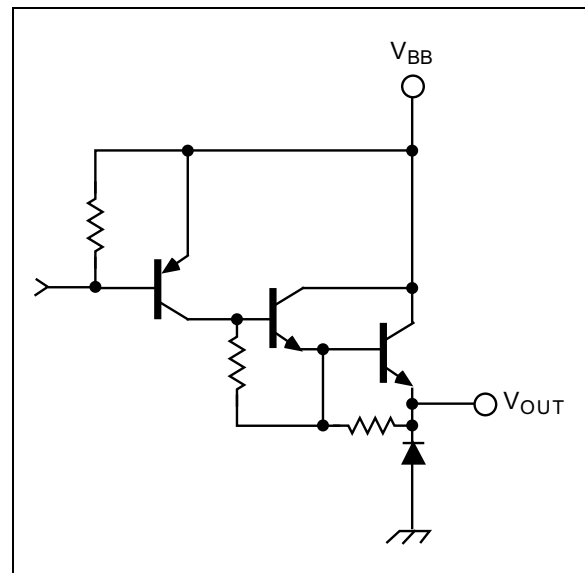

FIGURE 1-2: Typical Output Circuit.

MIC5891

2.0 TYPICAL PERFORMANCE CURVES

Note: The graphs and tables provided following this note are a statistical summary based on a limited number of samples and are provided for informational purposes only. The performance characteristics listed herein are not tested or guaranteed. In some graphs or tables, the data presented may be outside the specified operating range (e.g., outside specified power supply range) and therefore outside the warranted range.

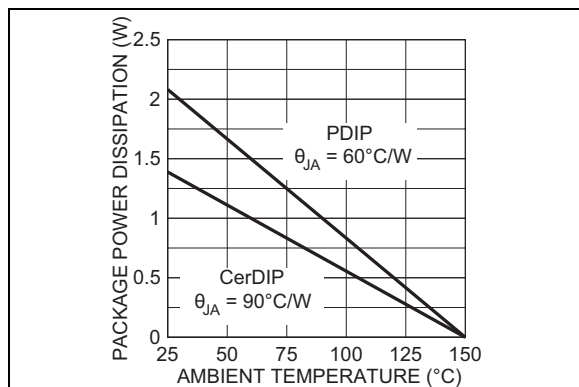

FIGURE 2-1: Allowable Package Power Dissipation vs. Temperature.

3.0 TIMING CONDITIONS

The descriptions of the timing conditions are listed below [Figure 3-1](#).

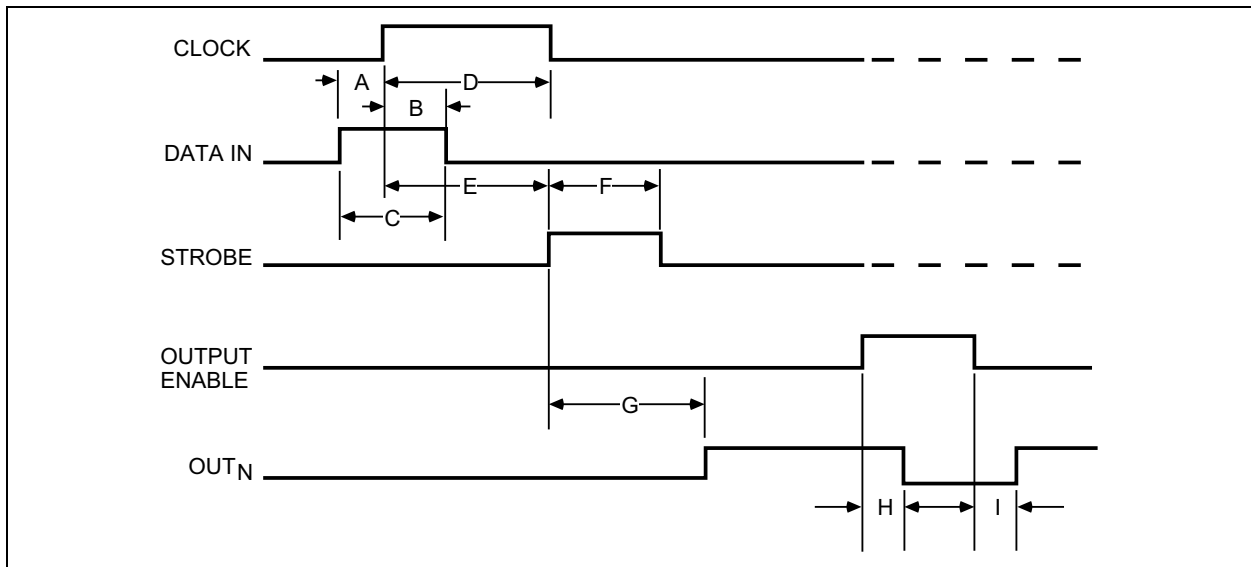

FIGURE 3-1: Timing Conditions.

TABLE 3-1: TIMING CONDITIONS PARAMETERS

V _{DD} = 5.0V, Logic levels are V _{DD} and ground.		
Reference	Parameter	Value
A	Minimum data active time before clock pulse (data set-up time)	75 ns
B	Minimum data active time after clock pulse (data hold time)	75 ns
C	Minimum data pulse width	150 ns
D	Minimum clock pulse width	150 ns
E	Minimum time between clock activation and strobe	300 ns
F	Minimum strobe pulse width	100 ns
G	Typical time between strobe activation and output transition	1.0 μs
H	Turn-off delay	See Electrical Characteristics
I	Turn-on delay	See Electrical Characteristics

TABLE 3-2: TRUTH TABLE

Serial Data Input	Clock Input	Shift Register Contents	Serial Data Output	Strobe Input	Latch Contents	Output Enable	Output Content
		I ₁ I ₂ I ₃ ... I _{N-1} I _N			I ₁ I ₂ I ₃ ... I _{N-1} I _N		I ₁ I ₂ I ₃ ... I _{N-1} I _N
H		H R ₁ R ₂ ... R _{N-2} R _{N-1}	R _{N-1}	—	—	—	—
L		L R ₁ R ₂ ... R _{N-2} R _{N-1}	R _{N-1}				
X		R ₁ R ₂ R ₃ ... R _{N-1} R _N	R _N				
—	—	X X X ... X X	X	L	R ₁ R ₂ R ₃ ... R _{N-1} R _N	L	P ₁ P ₂ P ₃ ... P _{N-1} P _N
		P ₁ P ₂ P ₃ ... P _{N-1} P _N	P _N	H	P ₁ P ₂ P ₃ ... P _{N-1} P _N		
		—	—	—	X X X ... X X		

L = Low Logic Level, H = High Logic Level, X = Irrelevant, P = Present State, R = Previous State.

4.0 APPLICATION INFORMATION

Serial data present at the input is transferred into the shift register on the rising edge of the CLOCK input pulse. Additional CLOCK pulses shift data information towards the SERIAL DATA OUTPUT. The serial data must appear at the input prior to the rising edge of the CLOCK input waveform.

The 8 bits present in the shift register are transferred to the respective latches when the STROBE is high (serial-to-parallel conversion). The latches will continue to accept new data as long as the STROBE is held high. Most applications where the latching feature is not used (STROBE tied high) require the OUTPUT ENABLE input to be high during serial data entry.

Outputs are active (controlled by the latch state) when the OUTPUT ENABLE is low. All outputs are low (disabled) when the OUTPUT ENABLE is high. OUTPUT ENABLE does not affect the data in the shift register or latch.

5.0 PACKAGING INFORMATION

5.1 Package Marking Information

16-Pin PDIP*



Example



16-Pin SOICW*



Example



Legend:	XX...X	Product code or customer-specific information
	Y	Year code (last digit of calendar year)
	YY	Year code (last 2 digits of calendar year)
	WW	Week code (week of January 1 is week '01')
	NNN	Alphanumeric traceability code
	(e3)	Pb-free JEDEC® designator for Matte Tin (Sn)
	*	This package is Pb-free. The Pb-free JEDEC designator (e3) can be found on the outer packaging for this package.
	•, ▲, ▼	Pin one index is identified by a dot, delta up, or delta down (triangle mark).
Note:	In the event the full Microchip part number cannot be marked on one line, it will be carried over to the next line, thus limiting the number of available characters for customer-specific information. Package may or may not include the corporate logo.	
	Underbar (¯) and/or Overbar (¯) symbol may not be to scale.	

MIC5891

NOTES:

APPENDIX A: REVISION HISTORY

Revision A (October 2016)

- Converted Micrel document MIC5891 to Microchip data sheet DS20005638A.
- Minor text changes throughout.
- Operating temperature range corrected in the [Temperature Specifications](#) section.
- Maximum Saturation Voltage values updated in [Table 1-2](#).
- First Input Current maximum value updated in [Table 1-2](#).

MIC5891

NOTES:

PRODUCT IDENTIFICATION SYSTEM

To order or obtain information, e.g., on pricing or delivery, contact your local Microchip representative or sales office.

<u>PART NO.</u>		X	XX	-	XX
Device	Junction Temperature Range	Package	Media Type		
Device:	MIC5891:	8-Bit Serial-Input Latched Source Driver			
Junction Temperature Range:	Y =	-40°C to +85°C			
Package:	N =	16-Lead PDIP			
	WM =	16-Lead SOICW			
Media Type:	TR =	1,000/Reel for WM Package			
	(blank)=	25/Tube for N Package			
	(blank)=	47/Tube for WM Package			

Examples:	
a) MIC5891YN:	8-Bit Serial-Input Latched Source Driver, -40°C to +85°C Junction Temperature Range, 16-Lead PDIP, 25/Tube
a) MIC5891YWM:	8-Bit Serial-Input Latched Source Driver, -40°C to +85°C Junction Temperature Range, 16-Lead SOICW, 47/Tube
a) MIC5891YWM-TR:	8-Bit Serial-Input Latched Source Driver, -40°C to +85°C Junction Temperature Range, 16-Lead SOICW, 1,000/Reel

MIC5891

NOTES:

Note the following details of the code protection feature on Microchip devices:

- Microchip products meet the specification contained in their particular Microchip Data Sheet.
- Microchip believes that its family of products is one of the most secure families of its kind on the market today, when used in the intended manner and under normal conditions.
- There are dishonest and possibly illegal methods used to breach the code protection feature. All of these methods, to our knowledge, require using the Microchip products in a manner outside the operating specifications contained in Microchip's Data Sheets. Most likely, the person doing so is engaged in theft of intellectual property.
- Microchip is willing to work with the customer who is concerned about the integrity of their code.
- Neither Microchip nor any other semiconductor manufacturer can guarantee the security of their code. Code protection does not mean that we are guaranteeing the product as “unbreakable.”

Code protection is constantly evolving. We at Microchip are committed to continuously improving the code protection features of our products. Attempts to break Microchip's code protection feature may be a violation of the Digital Millennium Copyright Act. If such acts allow unauthorized access to your software or other copyrighted work, you may have a right to sue for relief under that Act.

Information contained in this publication regarding device applications and the like is provided only for your convenience and may be superseded by updates. It is your responsibility to ensure that your application meets with your specifications. MICROCHIP MAKES NO REPRESENTATIONS OR WARRANTIES OF ANY KIND WHETHER EXPRESS OR IMPLIED, WRITTEN OR ORAL, STATUTORY OR OTHERWISE, RELATED TO THE INFORMATION, INCLUDING BUT NOT LIMITED TO ITS CONDITION, QUALITY, PERFORMANCE, MERCHANTABILITY OR FITNESS FOR PURPOSE. Microchip disclaims all liability arising from this information and its use. Use of Microchip devices in life support and/or safety applications is entirely at the buyer's risk, and the buyer agrees to defend, indemnify and hold harmless Microchip from any and all damages, claims, suits, or expenses resulting from such use. No licenses are conveyed, implicitly or otherwise, under any Microchip intellectual property rights unless otherwise stated.

Microchip received ISO/TS-16949:2009 certification for its worldwide headquarters, design and wafer fabrication facilities in Chandler and Tempe, Arizona; Gresham, Oregon and design centers in California and India. The Company's quality system processes and procedures are for its PIC® MCUs and dsPIC® DSCs, KEELoc® code hopping devices, Serial EEPROMs, microperipherals, nonvolatile memory and analog products. In addition, Microchip's quality system for the design and manufacture of development systems is ISO 9001:2000 certified.

**QUALITY MANAGEMENT SYSTEM
CERTIFIED BY DNV
= ISO/TS 16949 =**

Trademarks

The Microchip name and logo, the Microchip logo, AnyRate, dsPIC, FlashFlex, flexPWR, Heldo, JukeBlox, KeeLoq, KeeLoq logo, Klear, LANCheck, LINK MD, MediaLB, MOST, MOST logo, MPLAB, OptoLyzer, PIC, PICSTART, PIC32 logo, RightTouch, SpyNIC, SST, SST Logo, SuperFlash and UNI/O are registered trademarks of Microchip Technology Incorporated in the U.S.A. and other countries.

ClockWorks, The Embedded Control Solutions Company, ETHERSYNCH, Hyper Speed Control, HyperLight Load, IntelliMOS, mTouch, Precision Edge, and QUIET-WIRE are registered trademarks of Microchip Technology Incorporated in the U.S.A.

Analog-for-the-Digital Age, Any Capacitor, AnyIn, AnyOut, BodyCom, chipKIT, chipKIT logo, CodeGuard, dsPICDEM, dsPICDEM.net, Dynamic Average Matching, DAM, ECAN, EtherGREEN, In-Circuit Serial Programming, ICSP, Inter-Chip Connectivity, JitterBlocker, KlearNet, KlearNet logo, MiWi, motorBench, MPASM, MPF, MPLAB Certified logo, MPLIB, MPLINK, MultiTRAK, NetDetach, Omniscient Code Generation, PICDEM, PICDEM.net, PICkit, PICtail, PureSilicon, RightTouch logo, REAL ICE, Ripple Blocker, Serial Quad I/O, SQL, SuperSwitcher, SuperSwitcher II, Total Endurance, TSHARC, USBCheck, VariSense, ViewSpan, WiperLock, Wireless DNA, and ZENA are trademarks of Microchip Technology Incorporated in the U.S.A. and other countries.

SQTP is a service mark of Microchip Technology Incorporated in the U.S.A.

Silicon Storage Technology is a registered trademark of Microchip Technology Inc. in other countries.

GestIC is a registered trademarks of Microchip Technology Germany II GmbH & Co. KG, a subsidiary of Microchip Technology Inc., in other countries.

All other trademarks mentioned herein are property of their respective companies.

© 2016, Microchip Technology Incorporated, Printed in the U.S.A., All Rights Reserved.

ISBN: 978-1-5224-1034-8



MICROCHIP

Worldwide Sales and Service

AMERICAS

Corporate Office

2355 West Chandler Blvd.
Chandler, AZ 85224-6199

Tel: 480-792-7200

Fax: 480-792-7277

Technical Support:

[http://www.microchip.com/
support](http://www.microchip.com/support)

Web Address:

www.microchip.com

Atlanta

Duluth, GA

Tel: 678-957-9614

Fax: 678-957-1455

Austin, TX

Tel: 512-257-3370

Boston

Westborough, MA

Tel: 774-760-0087

Fax: 774-760-0088

Chicago

Itasca, IL

Tel: 630-285-0071

Fax: 630-285-0075

Cleveland

Independence, OH

Tel: 216-447-0464

Fax: 216-447-0643

Dallas

Addison, TX

Tel: 972-818-7423

Fax: 972-818-2924

Detroit

Novi, MI

Tel: 248-848-4000

Houston, TX

Tel: 281-894-5983

Indianapolis

Noblesville, IN

Tel: 317-773-8323

Fax: 317-773-5453

Los Angeles

Mission Viejo, CA

Tel: 949-462-9523

Fax: 949-462-9608

New York, NY

Tel: 631-435-6000

San Jose, CA

Tel: 408-735-9110

Canada - Toronto

Tel: 905-695-1980

Fax: 905-695-2078

ASIA/PACIFIC

Asia Pacific Office

Suites 3707-14, 37th Floor
Tower 6, The Gateway
Harbour City, Kowloon

Hong Kong

Tel: 852-2943-5100

Fax: 852-2401-3431

Australia - Sydney

Tel: 61-2-9868-6733

Fax: 61-2-9868-6755

China - Beijing

Tel: 86-10-8569-7000

Fax: 86-10-8528-2104

China - Chengdu

Tel: 86-28-8665-5511

Fax: 86-28-8665-7889

China - Chongqing

Tel: 86-23-8980-9588

Fax: 86-23-8980-9500

China - Dongguan

Tel: 86-769-8702-9880

China - Guangzhou

Tel: 86-20-8755-8029

China - Hangzhou

Tel: 86-571-8792-8115

Fax: 86-571-8792-8116

China - Hong Kong SAR

Tel: 852-2943-5100

Fax: 852-2401-3431

China - Nanjing

Tel: 86-25-8473-2460

Fax: 86-25-8473-2470

China - Qingdao

Tel: 86-532-8502-7355

Fax: 86-532-8502-7205

China - Shanghai

Tel: 86-21-5407-5533

Fax: 86-21-5407-5066

China - Shenyang

Tel: 86-24-2334-2829

Fax: 86-24-2334-2393

China - Shenzhen

Tel: 86-755-8864-2200

Fax: 86-755-8203-1760

China - Wuhan

Tel: 86-27-5980-5300

Fax: 86-27-5980-5118

China - Xian

Tel: 86-29-8833-7252

Fax: 86-29-8833-7256

ASIA/PACIFIC

China - Xiamen

Tel: 86-592-2388138

Fax: 86-592-2388130

China - Zhuhai

Tel: 86-756-3210040

Fax: 86-756-3210049

India - Bangalore

Tel: 91-80-3090-4444

Fax: 91-80-3090-4123

India - New Delhi

Tel: 91-11-4160-8631

Fax: 91-11-4160-8632

India - Pune

Tel: 91-20-3019-1500

Japan - Osaka

Tel: 81-6-6152-7160

Fax: 81-6-6152-9310

Japan - Tokyo

Tel: 81-3-6880-3770

Fax: 81-3-6880-3771

Korea - Daegu

Tel: 82-53-744-4301

Fax: 82-53-744-4302

Korea - Seoul

Tel: 82-2-554-7200

Fax: 82-2-558-5932 or

82-2-558-5934

Malaysia - Kuala Lumpur

Tel: 60-3-6201-9857

Fax: 60-3-6201-9859

Malaysia - Penang

Tel: 60-4-227-8870

Fax: 60-4-227-4068

Philippines - Manila

Tel: 63-2-634-9065

Fax: 63-2-634-9069

Singapore

Tel: 65-6334-8870

Fax: 65-6334-8850

Taiwan - Hsin Chu

Tel: 886-3-5778-366

Fax: 886-3-5770-955

Taiwan - Kaohsiung

Tel: 886-7-213-7828

Taiwan - Taipei

Tel: 886-2-2508-8600

Fax: 886-2-2508-0102

Thailand - Bangkok

Tel: 66-2-694-1351

Fax: 66-2-694-1350

EUROPE

Austria - Wels

Tel: 43-7242-2244-39

Fax: 43-7242-2244-393

Denmark - Copenhagen

Tel: 45-4450-2828

Fax: 45-4485-2829

France - Paris

Tel: 33-1-69-53-63-20

Fax: 33-1-69-30-90-79

Germany - Dusseldorf

Tel: 49-2129-3766400

Germany - Karlsruhe

Tel: 49-721-625370

Germany - Munich

Tel: 49-89-627-144-0

Fax: 49-89-627-144-44

Italy - Milan

Tel: 39-0331-742611

Fax: 39-0331-466781

Italy - Venice

Tel: 39-049-7625286

Netherlands - Drunen

Tel: 31-416-690399

Fax: 31-416-690340

Poland - Warsaw

Tel: 48-22-3325737

Spain - Madrid

Tel: 34-91-708-08-90

Fax: 34-91-708-08-91

Sweden - Stockholm

Tel: 46-8-5090-4654

UK - Wokingham



Tel: 44-118-921-5800

Fax: 44-118-921-5820

06/23/16

Looking for pricing, stock, or lifecycle information?

Click below to explore more details on WIN SOURCE:

-  [View MIC5891YN on WIN SOURCE](#)
-  [Microchip Technology](#) Information

Optimize Your Supply Chain with WIN SOURCE Solutions

-  Global Sourcing Solution
-  Obsolete Management
-  Cost Control Management
-  Shortage Management
-  Alternative Solution
-  Excess Inventory Management