



THE DATASHEET OF OPA694IDBVR





Wideband, Low-Power, Current Feedback Operational Amplifier

Check for Samples: [OPA694](#)

FEATURES

- **UNITY GAIN STABLE BANDWIDTH: 1.5GHz**
- **HIGH GAIN OF 2V/V BANDWIDTH: 690MHz**
- **LOW SUPPLY CURRENT: 5.8mA**
- **HIGH SLEW RATE: 1700V/ μ sec**
- **HIGH FULL-POWER BANDWIDTH: 675MHz**
- **LOW DIFFERENTIAL GAIN/PHASE:
0.03%/0.015°**
- **Pb-FREE AND GREEN SOT23-5 PACKAGE**

APPLICATIONS

- **WIDEBAND VIDEO LINE DRIVER**
- **MATRIX SWITCH BUFFER**
- **DIFFERENTIAL RECEIVER**
- **ADC DRIVER**
- **IMPROVED REPLACEMENT FOR OPA658**

OPA694 RELATED PRODUCTS

SINGLES	DUALS	TRIPLES	QUADS	FEATURES
—	OPA2694	—	—	Dual Version
OPA683	OPA2683	—	—	Low-Power, CFBPlus
OPA684	OPA2684	OPA3684	OPA4684	Low-Power, CFBPlus
OPA691	OPA2691	OPA3691	—	High Output
OPA695	OPA2695	OPA3695	—	High Intercept

DESCRIPTION

The OPA694 is an ultra-wideband, low-power, current feedback operational amplifier featuring high slew rate and low differential gain/phase errors. An improved output stage provides ± 80 mA output drive with < 1.5 V output voltage headroom. Low supply current with > 500 MHz bandwidth meets the requirements of high-density video routers. Being a current feedback design, the OPA694 holds its bandwidth to very high gains—at a gain of 10, the OPA694 will still provide 200MHz bandwidth.

RF applications can use the OPA694 as a low-power SAW pre-amplifier. Extremely high 3rd-order intercept is provided through 70MHz at much lower quiescent power than many typical RF amplifiers.

The OPA694 is available in an industry-standard pinout in both SO-8 and SOT23-5 packages.

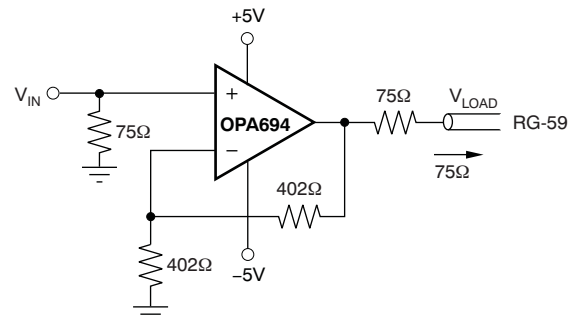

Gain 2V/V Video Line Driver



Please be aware that an important notice concerning availability, standard warranty, and use in critical applications of Texas Instruments semiconductor products and disclaimers thereto appears at the end of this data sheet.

All trademarks are the property of their respective owners.



This integrated circuit can be damaged by ESD. Texas Instruments recommends that all integrated circuits be handled with appropriate precautions. Failure to observe proper handling and installation procedures can cause damage.

ESD damage can range from subtle performance degradation to complete device failure. Precision integrated circuits may be more susceptible to damage because very small parametric changes could cause the device not to meet its published specifications.

ORDERING INFORMATION⁽¹⁾

PRODUCT	PACKAGE-LEAD	PACKAGE DESIGNATOR	SPECIFIED TEMPERATURE RANGE	PACKAGE MARKING	ORDERING NUMBER	TRANSPORT MEDIA, QUANTITY
OPA694	SO-8	D	-40°C to +85°C	OPA694	OPA694ID	Rails, 100
					OPA694IDR	Tape and Reel, 2500
OPA694	SOT23-5	DBV	-40°C to +85°C	BIA	OPA694IDBVT	Tape and Reel, 250
					OPA694IDBVR	Tape and Reel, 3000

(1) For the most current package and ordering information, see the Package Option Addendum located at the end of this data sheet, or see the TI web site at www.ti.com.

ABSOLUTE MAXIMUM RATINGS⁽¹⁾

Over operating free-air temperature range, unless otherwise noted.

	OPA694	UNIT
Power Supply	±6.5	V _{DC}
Internal Power Dissipation	See Thermal Characteristics	
Differential Input Voltage	±1.2	V
Input Voltage Range	±V _S	V
Storage Temperature Range: D, DBV	-65 to +125	°C
Junction Temperature (T _J)	+150	°C
ESD Ratings:	Human Body Model (HBM)	1500
	Charge Device Model (CDM)	1000
	Machine Model (MM)	100

(1) Stresses above these ratings may cause permanent damage. Exposure to absolute maximum conditions for extended periods may degrade device reliability. These are stress ratings only, and functional operation of the device at these or any other conditions beyond those specified is not supported.

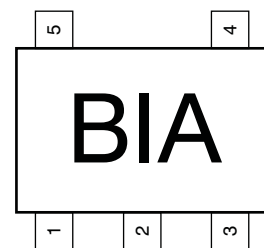
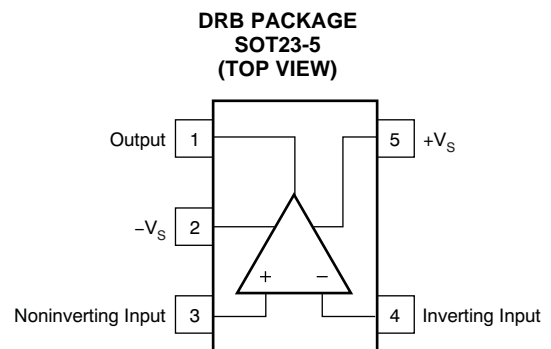
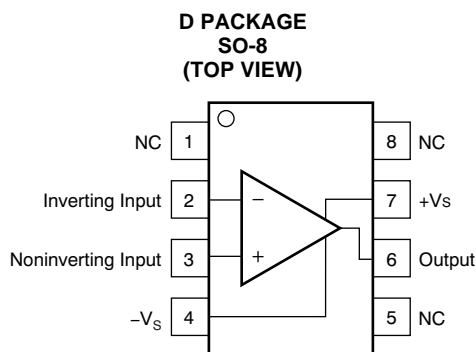

Pin Orientation/Package Marking

ELECTRICAL CHARACTERISTICS: $V_S = \pm 5V$
Boldface limits are tested at $+25^\circ\text{C}$. At $R_F = 402\Omega$, $R_L = 100\Omega$, and $G = +2V/V$, unless otherwise noted.

PARAMETER	TEST CONDITIONS	OPA694ID, IDBV				UNIT	MIN/ MAX	TEST LEVELS ⁽¹⁾
		TYP	MIN/MAX OVER TEMPERATURE					
			$+25^\circ\text{C}$	$+25^\circ\text{C}^{(2)}$	$0^\circ\text{C to } +70^\circ\text{C}^{(3)}$			
AC Performance (see Figure 31)								
Small-Signal Bandwidth	$G = +1, V_O = 0.5V_{PP}, R_F = 430\Omega$	1500				MHz	typ	C
	$G = +2, V_O = 0.5V_{PP}, R_F = 402\Omega$	690	350	340	330	MHz	min	B
	$G = +5, V_O = 0.5V_{PP}, R_F = 318\Omega$	250	200	180	160	MHz	min	B
	$G = +10, V_O = 0.5V_{PP}, R_F = 178\Omega$	200	150	130	120	MHz	min	B
Bandwidth for 0.1dB Gain Flatness	$G = +1, V_O = 0.5V_{PP}, R_F = 430\Omega$	90				MHz	typ	C
Peaking at a Gain of +1	$V_O \leq 0.1V_{PP}, R_F = 430\Omega$	2				dB	typ	C
Large-Signal Bandwidth	$G = +2, V_O = 2V_{PP}$	675				MHz	typ	C
Slew Rate	$G = +2, 2V$ Step	1700	1300	1275	1250	V/ μs	min	B
Rise Time and Fall Time	$G = +2, V_O = 0.2V$ Step	0.8				ns	typ	C
Settling Time to 0.01%	$G = +2, V_O = 2V$ Step	20				ns	typ	C
Settling Time to 0.1%	$G = +2, V_O = 2V$ Step	13				ns	typ	C
Harmonic Distortion	$G = +2, f = 5\text{MHz}, V_O = 2V_{PP}$					—	—	—
2nd-Harmonic	$R_L = 100\Omega$	-68	-63	-62	-61	dBc	max	B
	$R_L \geq 500\Omega$	-92	-87	-85	-83	dBc	max	B
3rd-Harmonic	$R_L = 100\Omega$	-72	-69	-67	-66	dBc	max	B
	$R_L \geq 500\Omega$	-93	-88	-86	-84	dBc	max	B
Input Voltage Noise Density	$f > 1\text{MHz}$	2.1	2.4	2.8	3.0	nV/ $\sqrt{\text{Hz}}$	max	B
Inverting Input Current Noise Density	$f > 1\text{MHz}$	22	24	26	28	pA/ $\sqrt{\text{Hz}}$	max	B
Noninverting Input Current Noise Density	$f > 1\text{MHz}$	24	26	28	30	pA/ $\sqrt{\text{Hz}}$	max	B
NTSC Differential Gain	$V_O - 1.4V_{PP}, R_L = 150\Omega$	0.03				%	max	C
	$V_O - 1.4V_{PP}, R_L = 37.5\Omega$	0.05				%	max	C
NTSC Differential Phase	$G = +2, V_O - 1.4V_{PP}, R_L = 150\Omega$	0.015				°	typ	C
	$V_O - 1.4V_{PP}, R_L = 37.5\Omega$	0.16				°	typ	C
DC PERFORMANCE⁽⁴⁾								
Open-Loop Transimpedance	$V_O = 0V, R_L = 100\Omega$	145	90	65	60	k Ω	min	A
Input Offset Voltage	$V_{CM} = 0V$	± 0.5	± 3.0	± 3.7	± 4.1	mV	max	A
Average Input Offset Voltage Drift	$V_{CM} = 0V$			12	15	$\mu\text{V}/^\circ\text{C}$	max	B
Noninverting Input Bias Current	$V_{CM} = 0V$	± 5	± 20	± 26	± 31	μA	max	A
Average Input Bias Current Drift	$V_{CM} = 0V$			± 100	± 150	nA/ $^\circ\text{C}$	max	B
Inverting Input Bias Current	$V_{CM} = 0V$	± 2	± 18	± 26	± 38	μA	max	A
Average Input Bias Current Drift	$V_{CM} = 0V$			± 150	± 200	nA/ $^\circ\text{C}$	max	B
INPUT								
Common-mode Input Voltage ⁽⁵⁾ (CMIR)		± 2.5	± 2.3	± 2.2	± 2.1	V	min	A
Common-Mode Rejection Ratio (CMRR)	$V_{CM} = 0V$	60	55	53	51	dB	min	A
Noninverting Input Impedance		280 1.2				k Ω pF	typ	C
Inverting Input Resistance	Open-Loop	30				Ω	typ	C

(1) Test levels: **(A)** 100% tested at $+25^\circ\text{C}$. Over temperature limits by characterization and simulation. **(B)** Limits set by characterization and simulation. **(C)** Typical value only for information.

(2) Junction temperature = ambient for $+25^\circ\text{C}$ specifications.

(3) Junction temperature = ambient at low temperature limits; junction temperature = ambient $+9^\circ\text{C}$ at high temperature limit for over temperature specifications.

(4) Current is considered positive out of node. V_{CM} is the input common-mode voltage.

(5) Tested $< 3\text{dB}$ below minimum specified CMRR at $\pm\text{CMIR}$ limits.

ELECTRICAL CHARACTERISTICS: $V_S = \pm 5V$ (continued)

Boldface limits are tested at **+25°C**. At $R_F = 402\Omega$, $R_L = 100\Omega$, and $G = +2V/V$, unless otherwise noted.

PARAMETER	TEST CONDITIONS	OPA694ID, IDBV				UNIT	MIN/ MAX	TEST LEVELS ⁽¹⁾
		TYP	MIN/MAX OVER TEMPERATURE					
		+25°C	+25°C ⁽²⁾	0°C to +70°C ⁽³⁾	-40°C to +85°C ⁽³⁾			
OUTPUT								
Voltage Output Voltage	No Load	±4	±3.8	±3.7	±3.6	V	min	A
	$R_L = 100\Omega$	±3.4	±3.1	±3.1	±3.0	V	min	A
Output Current	$V_O = 0V$	±80	±60	±58	±50	mA	min	A
Short-Circuit Output Current	$V_O = 0V$	±200				mA	min	C
Closed-Loop Output Impedance	$G = +2$, $f = 100kHz$	0.02				Ω	typ	C
POWER SUPPLY								
Specified Operating Voltage		±5				V	typ	C
Maximum Operating Voltage Range			±6.3	±6.3	±6.3	V	max	A
Minimum Operating Voltage Range			±3.5	±3.5	±3.5	V	max	B
Maximum Quiescent Current	$V_S = \pm 5V$	5.8	6.0	6.2	6.3	mA	max	A
Minimum Quiescent Current	$V_S = \pm 5V$	5.8	5.6	5.3	5.0	mA	min	A
Power-Supply Rejection Ratio (PSRR)	Input-Referred	58	54	52	50	dB	min	A
THERMAL CHARACTERISTICS								
Specification: ID, IDBV		-40 to +85				°C	typ	C
Thermal Resistance, θ_{JA}	Junction-to-Ambient	—				—	—	—
D SO-8		125				°C/W	typ	C
DBV SOT23		150				°C/W	typ	C

TYPICAL CHARACTERISTICS: $V_S = \pm 5V$

At $R_F = 402\Omega$, $R_L = 100\Omega$, and $G = +2V/V$, unless otherwise noted.

NONINVERTING SMALL-SIGNAL FREQUENCY RESPONSE

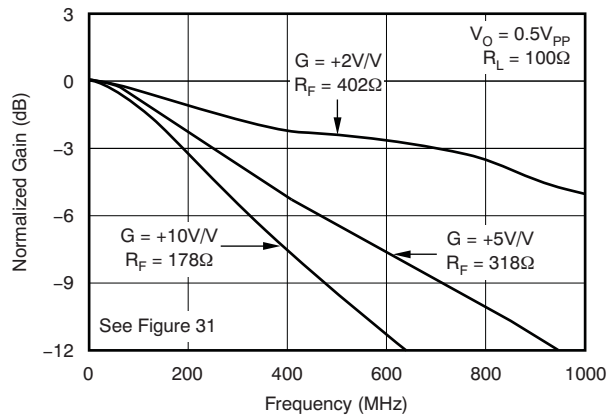

Figure 1.

INVERTING SMALL-SIGNAL FREQUENCY RESPONSE

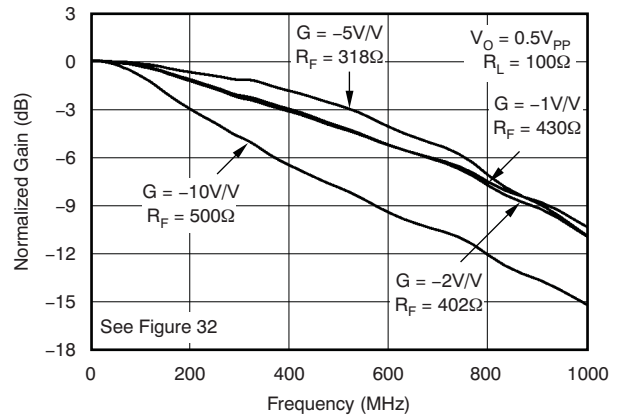

Figure 2.

NONINVERTING LARGE-SIGNAL FREQUENCY RESPONSE

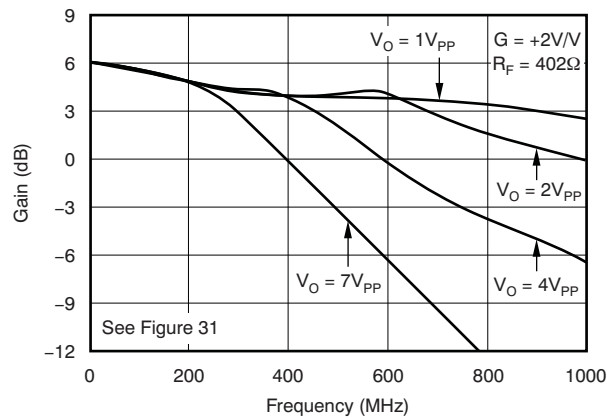

Figure 3.

INVERTING LARGE-SIGNAL FREQUENCY RESPONSE

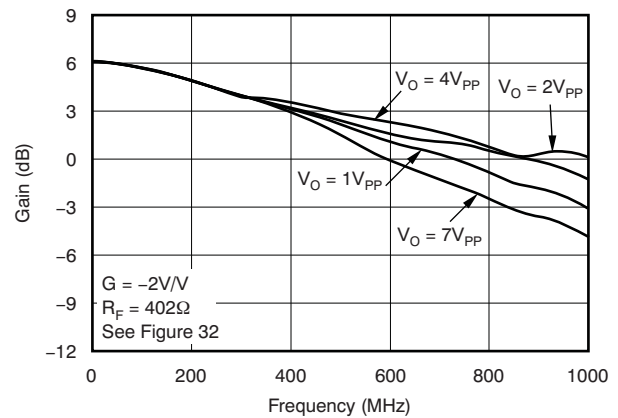

Figure 4.

NONINVERTING PULSE RESPONSE

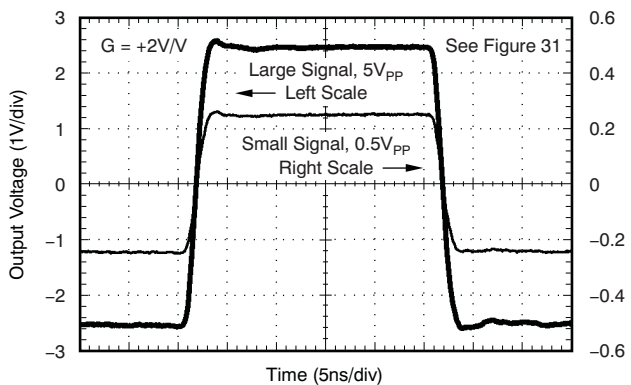

Figure 5.

INVERTING PULSE RESPONSE

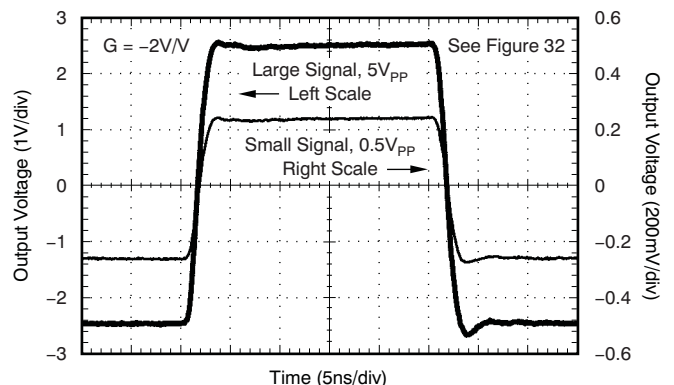

Figure 6.

TYPICAL CHARACTERISTICS: $V_S = \pm 5V$ (continued)

At $R_F = 402\Omega$, $R_L = 100\Omega$, and $G = +2V/V$, unless otherwise noted.

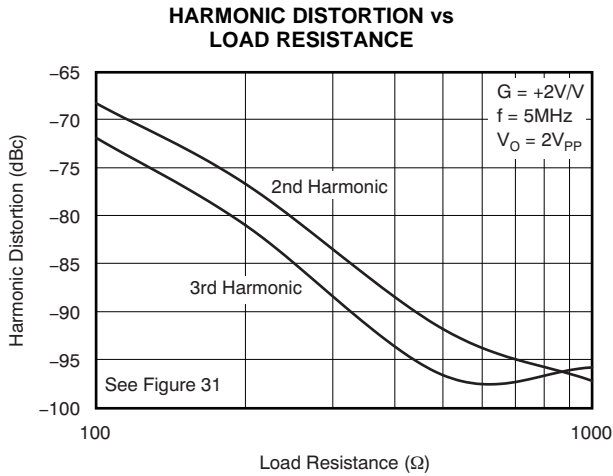

Figure 7.

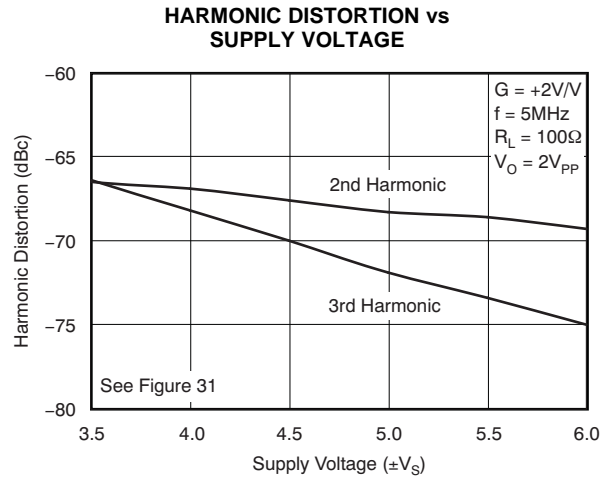

Figure 8.

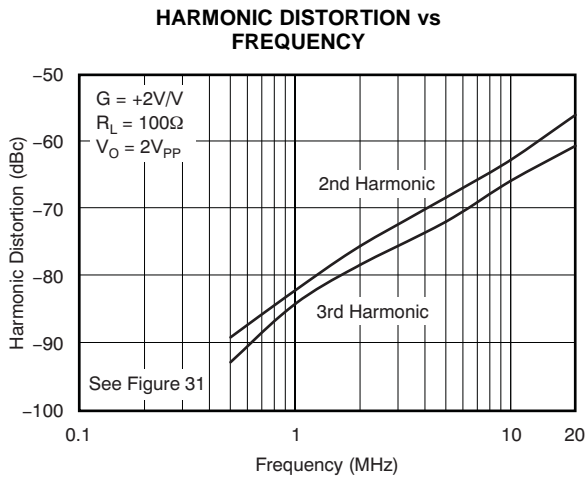

Figure 9.

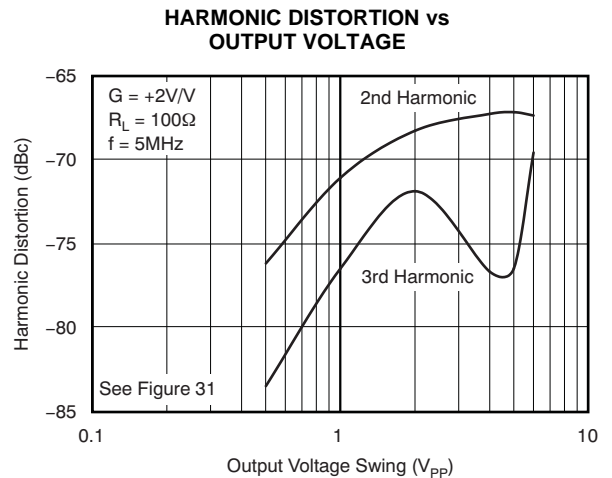

Figure 10.

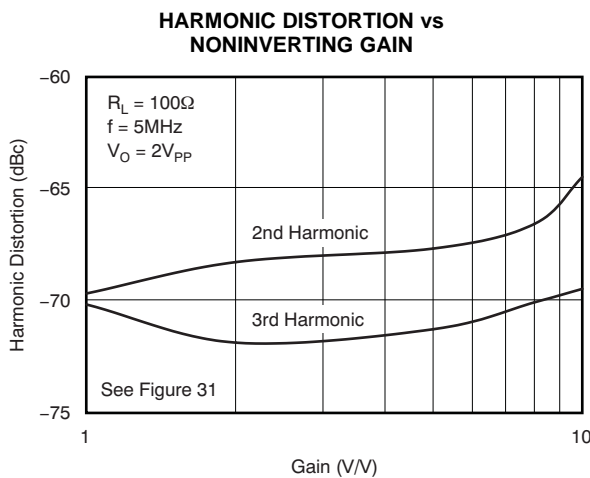

Figure 11.

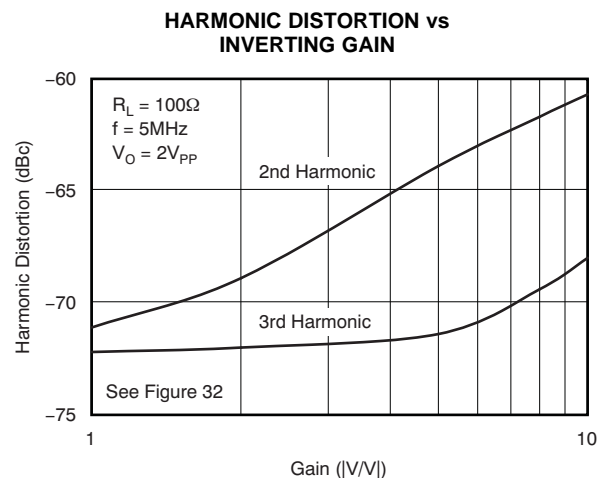

Figure 12.

TYPICAL CHARACTERISTICS: $V_S = \pm 5V$ (continued)

At $R_F = 402\Omega$, $R_L = 100\Omega$, and $G = +2V/V$, unless otherwise noted.

INPUT VOLTAGE AND CURRENT NOISE

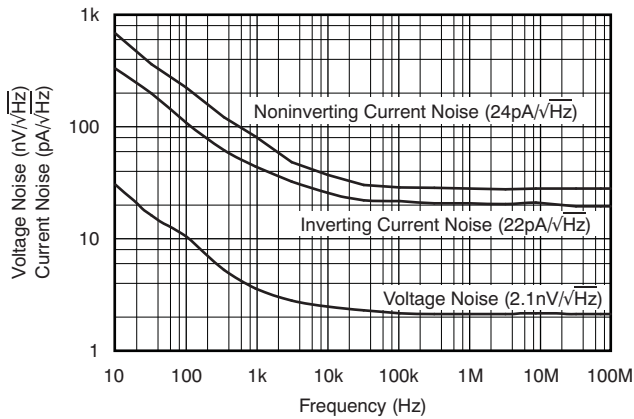

Figure 13.

TWO-TONE, THIRD-ORDER INTERMODULATION INTERCEPT

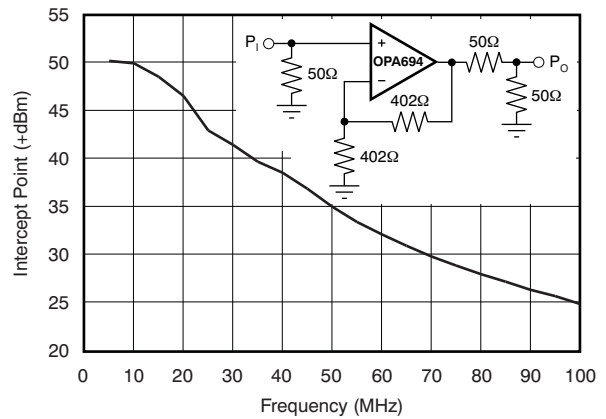

Figure 14.

RECOMMENDED R_S vs CAPACITIVE LOAD

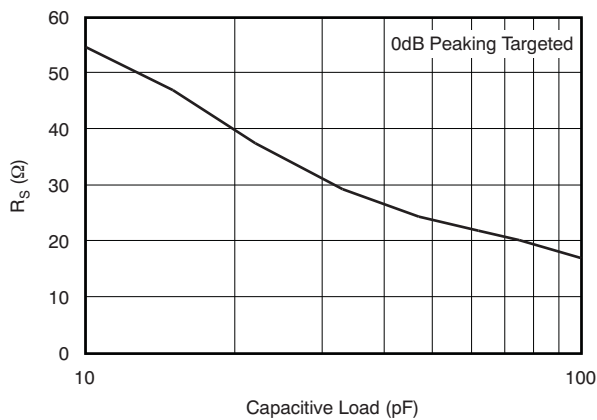

Figure 15.

FREQUENCY RESPONSE vs CAPACITIVE LOAD

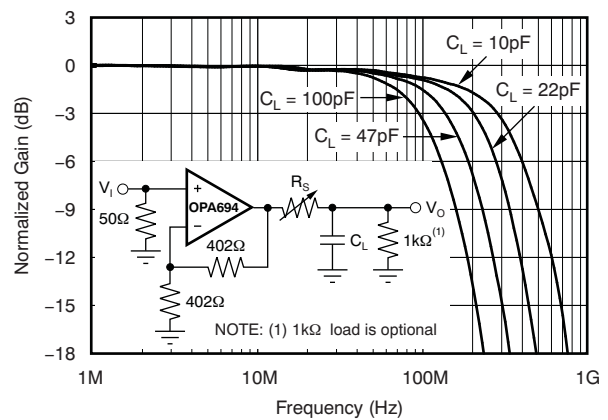

Figure 16.

COMMON-MODE REJECTION RATIO AND POWER-SUPPLY REJECTION RATIO vs FREQUENCY

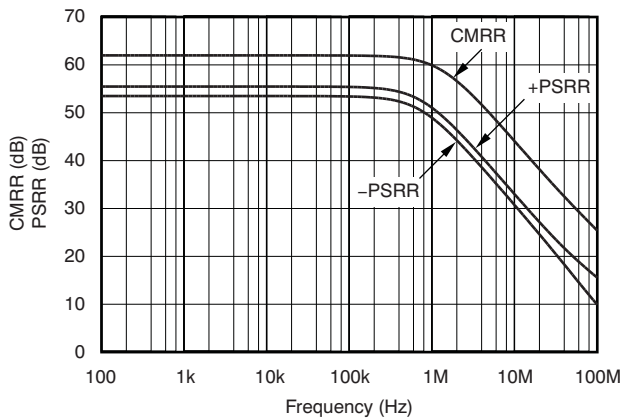

Figure 17.

OPEN-LOOP Z_{OL} GAIN AND PHASE

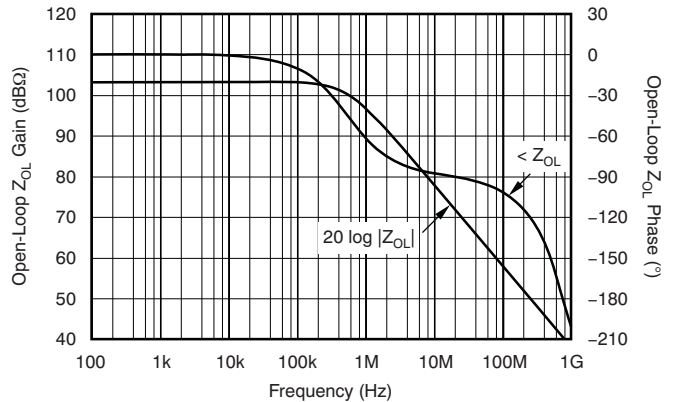

Figure 18.

TYPICAL CHARACTERISTICS: $V_S = \pm 5V$ (continued)

At $R_F = 402\Omega$, $R_L = 100\Omega$, and $G = +2V/V$, unless otherwise noted.

VIDEO DIFFERENTIAL GAIN/DIFFERENTIAL PHASE (No Pulldown)

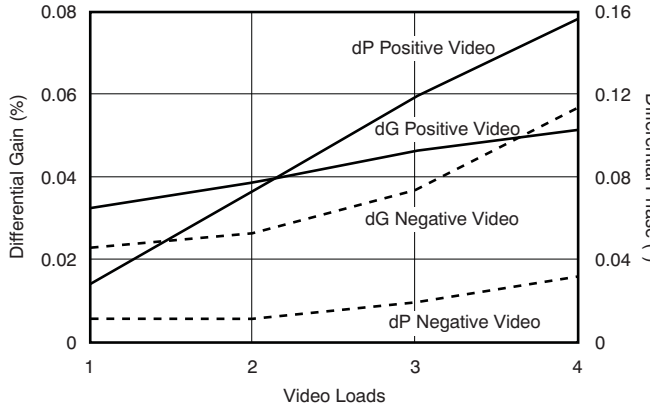

Figure 19.

TYPICAL DC DRIFT OVER TEMPERATURE

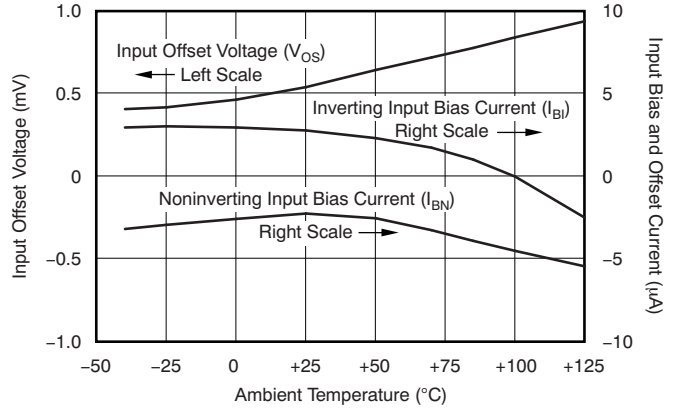

Figure 20.

OUTPUT VOLTAGE AND CURRENT LIMITATIONS

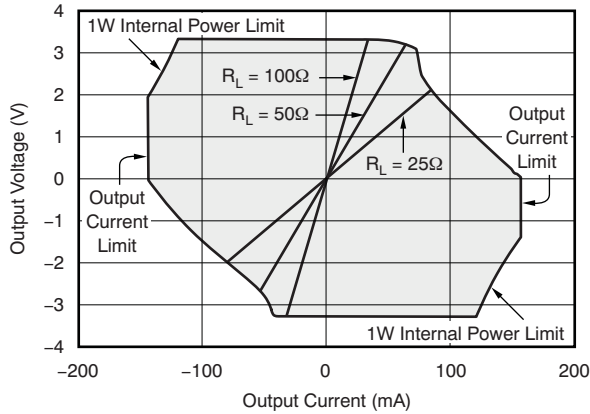

Figure 21.

SUPPLY AND OUTPUT CURRENT vs TEMPERATURE

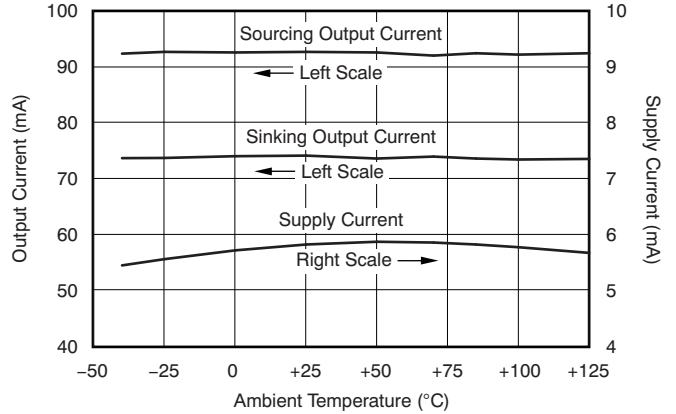

Figure 22.

NONINVERTING OVERDRIVE RECOVERY

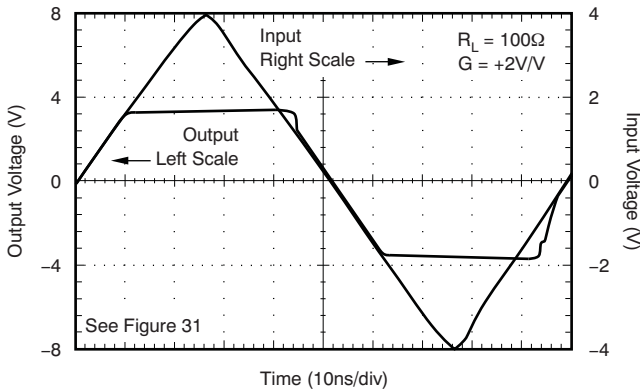

Figure 23.

INVERTING OVERDRIVE RECOVERY

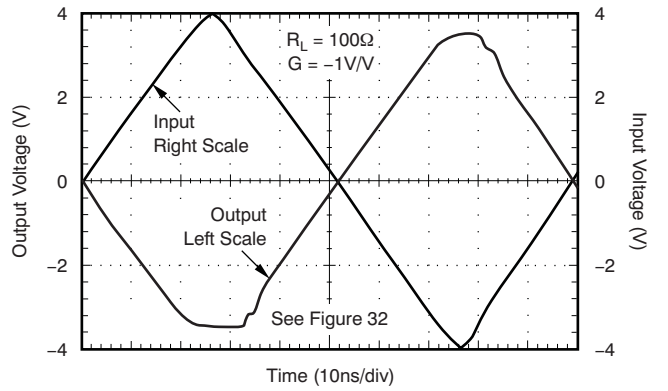

Figure 24.

TYPICAL CHARACTERISTICS: $V_S = \pm 5V$ (continued)

At $R_F = 402\Omega$, $R_L = 100\Omega$, and $G = +2V/V$, unless otherwise noted.

DIFFERENTIAL PERFORMANCE TEST CIRCUIT

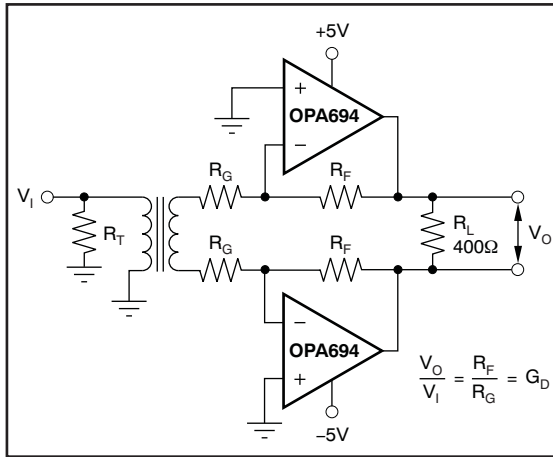

Figure 25.

DIFFERENTIAL SMALL-SIGNAL FREQUENCY RESPONSE

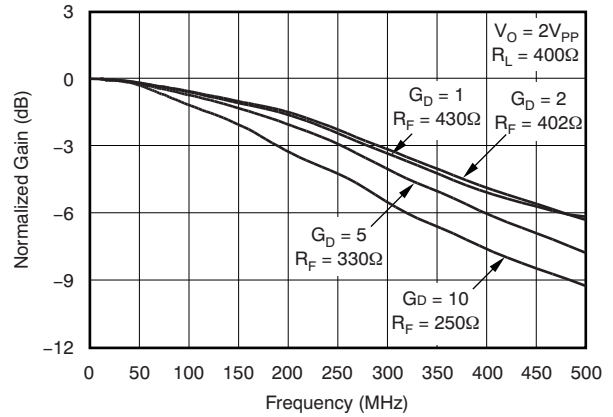

Figure 26.

DIFFERENTIAL LARGE-SIGNAL FREQUENCY RESPONSE

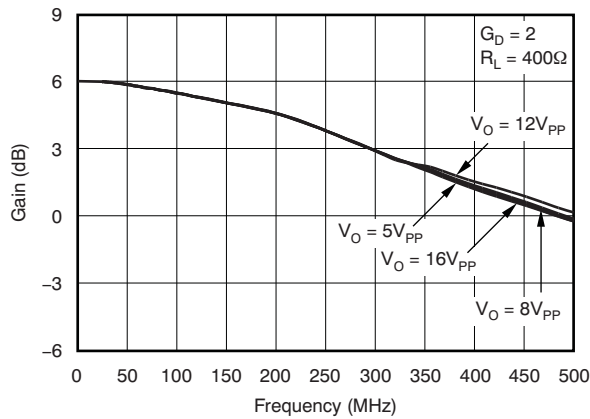

Figure 27.

DIFFERENTIAL DISTORTION vs LOAD RESISTANCE

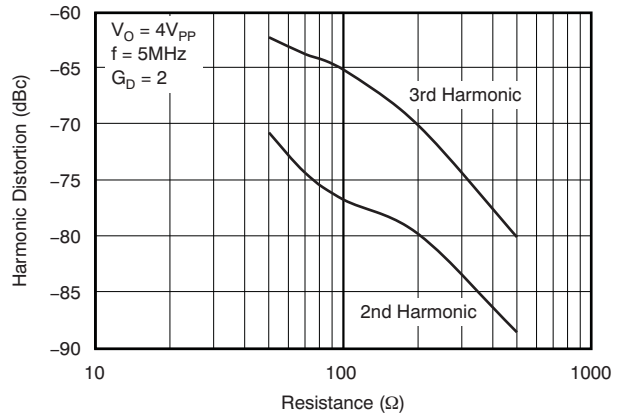

Figure 28.

DIFFERENTIAL DISTORTION vs FREQUENCY

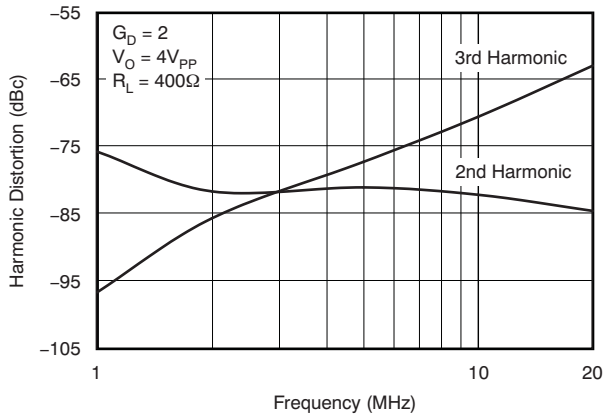

Figure 29.

DIFFERENTIAL DISTORTION vs OUTPUT VOLTAGE

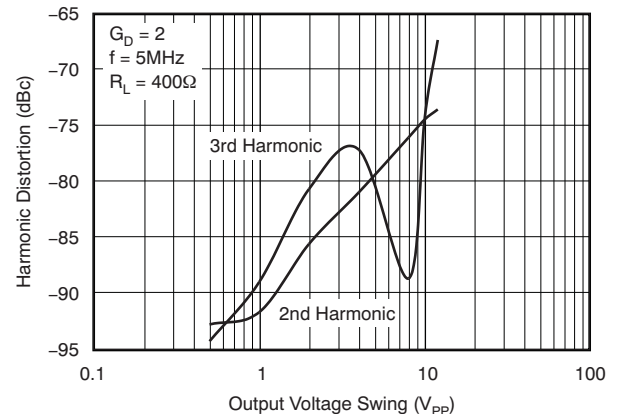

Figure 30.

APPLICATION INFORMATION

WIDEBAND CURRENT FEEDBACK OPERATION

The OPA694 provides exceptional AC performance for a wideband, low-power, current-feedback operational amplifier. Requiring only 5.8mA quiescent current, the OPA694 offers a 690MHz bandwidth at a gain of +2, along with a 1700V/ μ s slew rate. An improved output stage provides \pm 80mA output drive, along with < 1.5V output voltage headroom. This combination of low power and high bandwidth can benefit high-resolution video applications.

Figure 31 shows the DC-coupled, gain of +2, dual power-supply circuit configuration used as the basis of the \pm 5V Electrical Characteristics table and Typical Characteristic curves. For test purposes, the input impedance is set to 50 Ω with a resistor to ground and the output impedance is set to 50 Ω with a series output resistor. Voltage swings reported in the Electrical Characteristics are taken directly at the input and output pins, while load powers (dBm) are defined at a matched 50 Ω load. For the circuit of Figure 31, the total effective load will be 100 Ω || 804 Ω = 89 Ω . One optional component is included in Figure 31. In addition to the usual power-supply decoupling capacitors to ground, a 0.1 μ F capacitor is included between the two power-supply pins. In practical printed circuit board (PCB) layouts, this optional added capacitor will typically improve the 2nd-harmonic distortion performance by 3dB to 6dB.

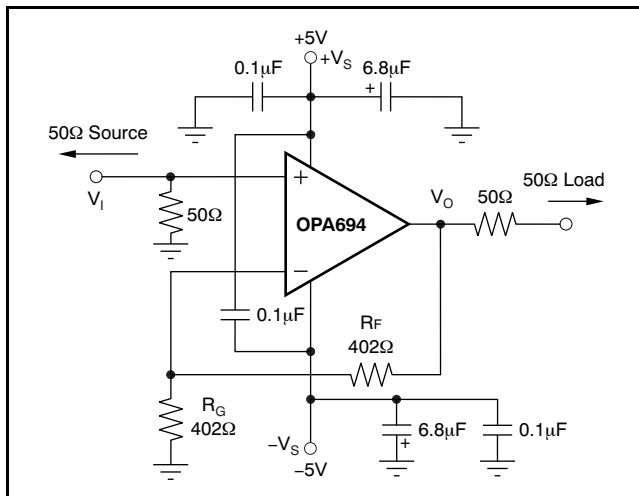

Figure 31. DC-Coupled, G = +2, Bipolar-Supply Specification and Test Circuit

Figure 32 shows the DC-coupled, gain of $-2V/V$, dual power-supply circuit used as the basis of the inverting Typical Characteristic curves. Inverting operation offers several performance benefits. Since there is no common-mode signal across the input stage, the slew

rate for inverting operation is higher and the distortion performance is slightly improved. An additional input resistor, R_T , is included in Figure 32 to set the input impedance equal to 50 Ω . The parallel combination of R_T and R_G sets the input impedance. Both the noninverting and inverting applications of Figure 31 and Figure 32 will benefit from optimizing the feedback resistor (R_F) value for bandwidth (see the discussion in the [Setting Resistor Values to Optimize Bandwidth](#) section). The typical design sequence is to select the R_F value for best bandwidth, set R_G for the gain, then set R_T for the desired input impedance. As the gain increases for the inverting configuration, a point will be reached where R_G will equal 50 Ω , where R_T is removed and the input match is set by R_G only. With R_G fixed to achieve an input match to 50 Ω , R_F is simply increased, to increase gain. This will, however, quickly reduce the achievable bandwidth, as shown by the inverting gain of -10 frequency response in the Typical Characteristic curves. For gains > 10V/V (14dB at the matched load), noninverting operation is recommended to maintain broader bandwidth.

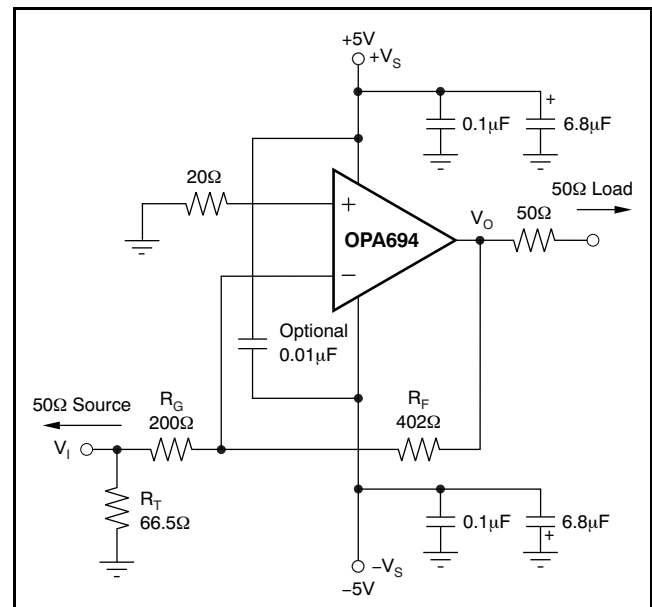

Figure 32. DC-Coupled, G = $-2V/V$, Bipolar-Supply Specification and Test Circuit

ADC DRIVER

Most modern, high-performance analog-to-digital converters (ADCs) require a low-noise, low-distortion driver. The OPA694 combines low-voltage noise (2.1nV/ $\sqrt{\text{Hz}}$) with low harmonic distortion. See Figure 33 for an example of a wideband, AC-coupled, 12-bit ADC driver.

Two OPA694s are used in the circuit of [Figure 33](#) to form a differential driver for a 12-bit ADC. The two OPA694s offer > 250MHz bandwidth at a differential gain of 5V/V, with a 2V_{PP} output swing. A 2nd-order RLC filter is used in order to limit the noise from the amplifier and provide some attenuation for higher-frequency harmonic distortion.

WIDEBAND INVERTING SUMMING AMPLIFIER

Since the signal bandwidth for a current-feedback op amp can be controlled independently of the noise gain (NG, which is normally the same as the noninverting signal gain), wideband inverting summing stages may be implemented using the OPA694. The circuit in [Figure 34](#) shows an example inverting summing amplifier, where the resistor values

have been adjusted to maintain both maximum bandwidth and input impedance matching. If each R_F signal is assumed to be driven from a 50Ω source, the NG for this circuit will be $[1 + 100\Omega/(100\Omega/5)] = 6$. The total feedback impedance (from V_O to the inverting error current) is the sum of R_F + (R₁ • NG), where R₁ is the impedance looking into the inverting input from the summing junction (see the [Setting Resistor Values to Optimize Performance](#) section). Using 100Ω feedback (to get a signal gain of -2 from each input to the output pin) requires an additional 30Ω in series with the inverting input to increase the feedback impedance. With this resistor added to the typical internal R₁ = 30Ω, the total feedback impedance is 100Ω + (60Ω • 6) = 460Ω, which is equal to the required value to get a maximum bandwidth flat frequency response for NG = 6.

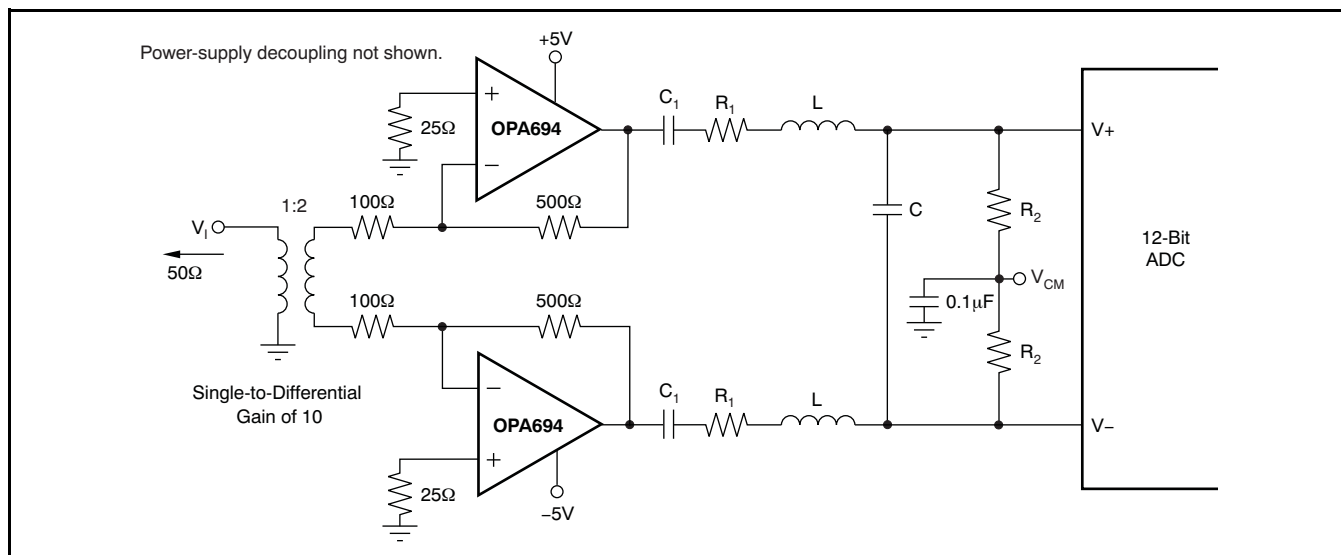

Figure 33. Wideband, AC-Coupled, Low-Power ADC Driver

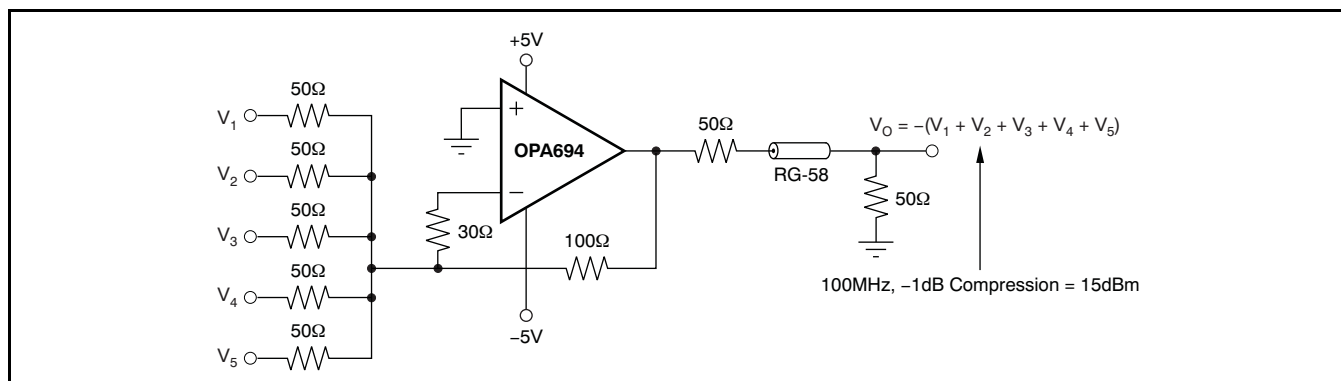

Figure 34. 200MHz RF Summing Amplifier

SAW FILTER BUFFER

One common requirement in an IF strip is to buffer the output of a mixer with enough gain to recover the insertion loss of a narrowband SAW filter. Figure 35 shows one possible configuration driving a SAW filter. The *Two-Tone, Third-Order Intermodulation Intercept* plot (Figure 14) is shown in the Typical Characteristics curves. Operating in the inverting mode at a voltage gain of $-8V/V$, this circuit provides a 50Ω input match using the gain set resistor, has the feedback optimized for maximum bandwidth (250MHz in this case), and drives through a 50Ω output resistor into the matching network at the input of the SAW filter. If the SAW filter gives a 12dB insertion loss, a net gain of 0dB to the 50Ω load at the output of the SAW (which could be the input impedance of the next IF amplifier or mixer) will be delivered in the passband of the SAW filter. Using the OPA694 in this application will isolate the first mixer from the impedance of the SAW filter and provide very low two-tone, 3rd-order spurious levels in the SAW filter bandwidth.

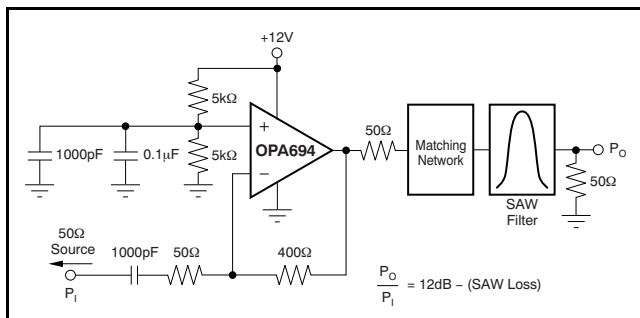

Figure 35. IF Amplifier Driving SAW Filter

WIDEBAND UNITY GAIN BUFFER WITH IMPROVED FLATNESS

The unity gain buffer configuration of Figure 31 shows a peaking in the frequency response exceeding 2dB. This gives the slight amount of overshoot and ringing apparent in the gain of $+1V/V$ pulse response curves. A similar circuit that holds a flatter frequency response, giving improved pulse fidelity, is shown in Figure 36.

This circuit removes the peaking by bootstrapping out any parasitic effects on R_G . The input impedance is still set by R_M as the apparent impedance looking into R_G is very high. R_M may be increased to show a higher input impedance, but larger values will start to impact DC output offset voltage. This circuit creates an additional input offset voltage as the difference in the two input bias currents times the impedance to ground at V_I . Figure 37 shows a comparison of

small-signal frequency response for the unity gain buffer of Figure 31 compared to the improved approach shown in Figure 36. Either approach gives a low-power unity-gain buffer with $> 1.56\text{GHz}$ bandwidth.

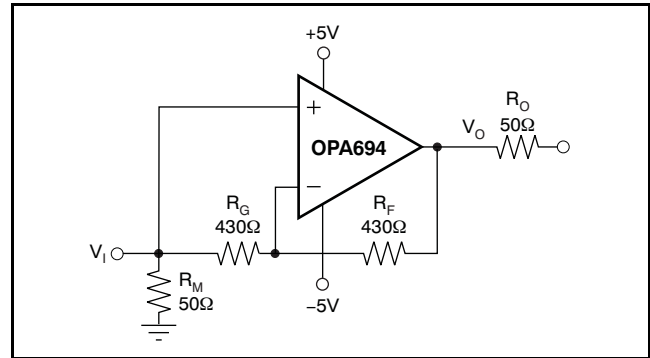

Figure 36. Improve Unity Gain Buffer

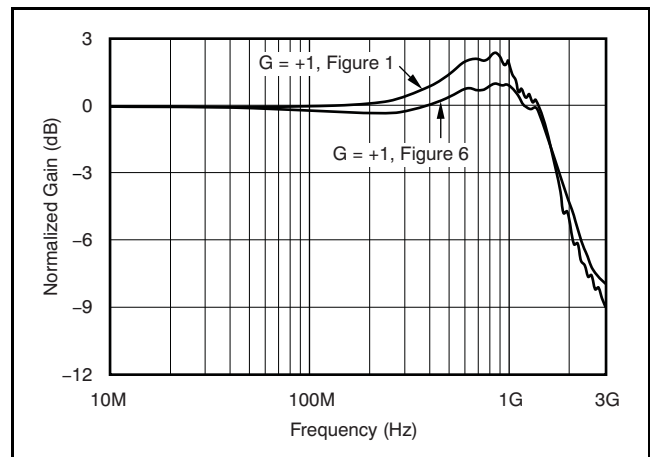

Figure 37. Gain of +1 Frequency Response

DESIGN-IN TOOLS

DEMONSTRATION FIXTURES

Two printed circuit boards (PCBs) are available to assist in the initial evaluation of circuit performance using the OPA694 in its two package options. Both of these are offered free of charge as unpopulated PCBs, delivered with a user's guide. The summary information for these fixtures is shown in Table 1.

Table 1. Demonstration Fixtures by Package

PRODUCT	PACKAGE	ORDERING NUMBER	LITERATURE NUMBER
OPA694ID	SO-8	DEM-OPA-SO-1B	SBOU026
OPA694IDBV	SOT23-5	DEM-OPA-SOT-1B	SBOU027

The demonstration fixtures can be requested at the Texas Instruments web site (www.ti.com) through the [OPA694 product folder](#).

MACROMODELS AND APPLICATIONS SUPPORT

Computer simulation of circuit performance using SPICE is often useful when analyzing the performance of analog circuits and systems. This is particularly true for video and RF amplifier circuits where parasitic capacitance and inductance can have a major effect on circuit performance. A SPICE model for the OPA694 is available through the TI web site (www.ti.com). These models do a good job of predicting small-signal AC and transient performance under a wide variety of operating conditions. They do not do as well in predicting the harmonic distortion or dG/dφ characteristics. These models do not attempt to distinguish between package types in their small-signal AC performance.

OPERATING SUGGESTIONS

SETTING RESISTOR VALUES TO OPTIMIZE BANDWIDTH

A current-feedback op amp like the OPA694 can hold an almost constant bandwidth over signal gain settings with the proper adjustment of the external resistor values. This is shown in the Typical Characteristic curves; the small-signal bandwidth decreases only slightly with increasing gain. Those curves also show that the feedback resistor has been changed for each gain setting. The resistor values on the inverting side of the circuit for a current-feedback op amp can be treated as frequency response compensation elements while their ratios set the signal gain. [Figure 38](#) shows the small-signal frequency response analysis circuit for the OPA694.

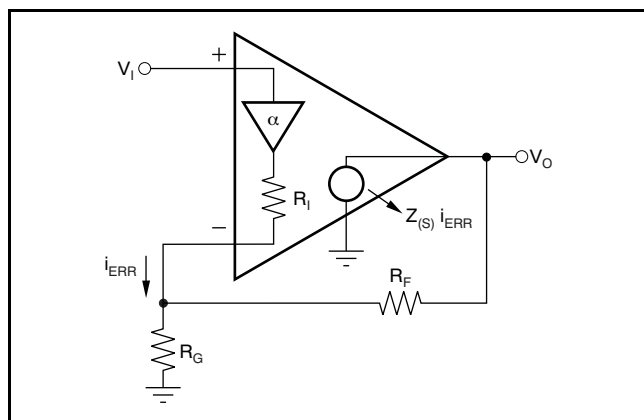

Figure 38. Recommended Feedback Resistor Versus Noise Gain

The key elements of this current-feedback op amp model are:

- α → Buffer gain from the noninverting input to the inverting input
- R_i → Buffer output impedance
- i_{ERR} → Feedback error current signal
- $Z(s)$ → Frequency-dependent, open-loop transimpedance gain from i_{ERR} to V_O

The buffer gain is typically very close to 1.00 and is normally neglected from signal gain considerations. It will, however, set the CMRR for a single op amp differential amplifier configuration.

For a buffer gain $\alpha < 1.0$, the CMRR = $-20 \times \log(1 - \alpha)$ dB.

R_i , the buffer output impedance, is a critical portion of the bandwidth control equation. R_i for the OPA694 is typically about 30Ω.

A current-feedback op amp senses an error current in the inverting node (as opposed to a differential input error voltage for a voltage-feedback op amp) and passes this on to the output through an internal frequency dependent transimpedance gain. The Typical Characteristics show this open-loop transimpedance response. This is analogous to the open-loop voltage gain curve for a voltage-feedback op amp. Developing the transfer function for the circuit of [Figure 38](#) gives [Equation 1](#):

$$\frac{V_O}{V_I} = \frac{\alpha \left(1 + \frac{R_F}{R_G}\right)}{1 + \frac{R_F + R_i \left(1 + \frac{R_F}{R_G}\right)}{Z(s)}} = \frac{\alpha NG}{\frac{R_F + R_i \cdot NG}{Z(s)}} \quad (1)$$

where:

$$NG = \left(1 + \frac{R_F}{R_G}\right)$$

This is written in a loop-gain analysis format, where the errors arising from a noninfinite open-loop gain are shown in the denominator. If $Z(s)$ were infinite over all frequencies, the denominator of [Equation 1](#) would reduce to 1 and the ideal desired signal gain shown in the numerator would be achieved. The fraction in the denominator of [Equation 1](#) determines the frequency response. [Equation 2](#) shows this as the loop-gain equation:

$$\frac{Z(s)}{R_F + R_i \cdot NG} = \text{Loop Gain} \quad (2)$$

If $20 \times \log(R_F + NG \times R_i)$ were drawn on top of the open-loop transimpedance plot, the difference between the two would be the loop gain at a given frequency. Eventually, $Z(s)$ rolls off to equal the denominator of [Equation 2](#), at which point the loop

gain reduces to 1 (and the curves intersect). This point of equality is where the amplifier closed-loop frequency response given by Equation 1 starts to roll off, and is exactly analogous to the frequency at which the noise gain equals the open-loop voltage gain for a voltage-feedback op amp. The difference here is that the total impedance in the denominator of Equation 2 may be controlled somewhat separately from the desired signal gain (or NG).

The OPA694 is internally compensated to give a maximally flat frequency response for $R_F = 402\Omega$ at $NG = 2$ on $\pm 5V$ supplies. Evaluating the denominator of Equation 2 (which is the feedback transimpedance) gives an optimal target of 462Ω . As the signal gain changes, the contribution of the $NG \times R_i$ term in the feedback transimpedance will change, but the total can be held constant by adjusting R_F . Equation 3 gives an approximate equation for optimum R_F over signal gain:

$$R_F = 462\Omega - NG \cdot R_i \quad (3)$$

As the desired signal gain increases, this equation will eventually predict a negative R_F . A somewhat subjective limit to this adjustment can also be set by holding R_G to a minimum value of 20Ω . Lower values will load both the buffer stage at the input and the output stage, if R_F gets too low, actually decreasing the bandwidth. Figure 39 shows the recommended R_F versus NG for $\pm 5V$ operation. The values for R_F versus gain shown here are approximately equal to the values used to generate the Typical Characteristics. They differ in that the optimized values used in the Typical Characteristics are also correcting for board parasitics not considered in the simplified analysis leading to Equation 2. The values shown in Figure 39 give a good starting point for design where bandwidth optimization is desired.

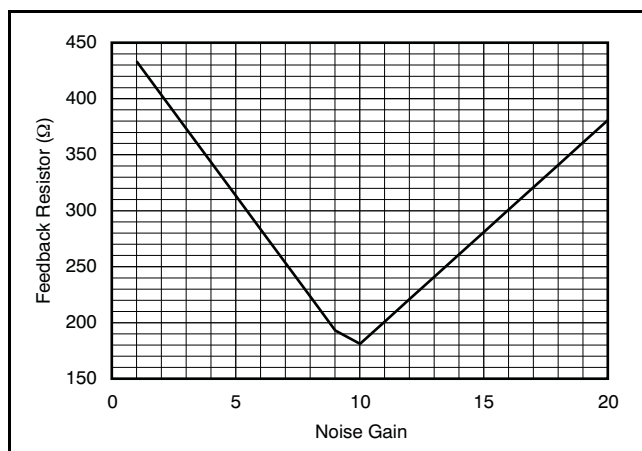

Figure 39. Feedback Resistor vs Noise Gain

The total impedance going into the inverting input may be used to adjust the closed-loop signal

bandwidth. Inserting a series resistor between the inverting input and the summing junction will increase the feedback impedance (denominator of Equation 1), decreasing the bandwidth. This approach to bandwidth control is used for the inverting summing circuit on the front page. The internal buffer output impedance for the OPA694 is slightly influenced by the source impedance looking out of the noninverting input terminal. High source resistors will have the effect of increasing R_i , decreasing the bandwidth.

OUTPUT CURRENT AND VOLTAGE

The OPA694 provides output voltage and current capabilities that are not usually found in wideband amplifiers. Under no-load conditions at $+25^\circ\text{C}$, the output voltage typically swings closer than $1.2V$ to either supply rail; the $+25^\circ\text{C}$ swing limit is within $1.2V$ of either rail. Into a 15Ω load (the minimum tested load), it is tested to deliver more than $\pm 60\text{mA}$.

The specifications described above, though familiar in the industry, consider voltage and current limits separately. In many applications, it is the (voltage \times current), or $V \cdot I$ product, which is more relevant to circuit operation. Refer to the *Output Voltage and Current Limitations* plot (Figure 21) in the Typical Characteristics. The X and Y axes of this graph show the zero-voltage output current limit and the zero-current output voltage limit, respectively. The four quadrants give a more detailed view of the OPA694 output drive capabilities, noting that the graph is bounded by a Safe Operating Area of $1W$ maximum internal power dissipation. Superimposing resistor load lines onto the plot shows that the OPA694 can drive $\pm 2.5V$ into 25Ω or $\pm 3.5V$ into 50Ω without exceeding the output capabilities or the $1W$ dissipation limit. A 100Ω load line (the standard test circuit load) shows the full $\pm 3.4V$ output swing capability, as shown in the Electrical Characteristics.

The minimum specified output voltage and current over-temperature are set by worst-case simulations at the cold temperature extreme. Only at cold startup will the output current and voltage decrease to the numbers shown in the Electrical Characteristic tables. As the output transistors deliver power, the junction temperatures will increase, decreasing both V_{BE} (increasing the available output voltage swing) and increasing the current gains (increasing the available output current). In steady-state operation, the available output voltage and current will always be greater than that shown in the over-temperature specifications, since the output stage junction temperatures will be higher than the minimum specified operating ambient.

DRIVING CAPACITIVE LOADS

One of the most demanding and yet very common load conditions for an op amp is capacitive loading. Often, the capacitive load is the input of an ADC—including additional external capacitance that may be recommended to improve ADC linearity. A high-speed, high open-loop gain amplifier like the OPA694 can be very susceptible to decreased stability and closed-loop response peaking when a capacitive load is placed directly on the output pin. When the amplifier open-loop output resistance is considered, this capacitive load introduces an additional pole in the signal path that can decrease the phase margin. Several external solutions to this problem have been suggested. When the primary considerations are frequency response flatness, pulse response fidelity, and/or distortion, the simplest and most effective solution is to isolate the capacitive load from the feedback loop by inserting a series isolation resistor between the amplifier output and the capacitive load. This does not eliminate the pole from the loop response, but rather shifts it and adds a zero at a higher frequency. The additional zero acts to cancel the phase lag from the capacitive load pole, thus increasing the phase margin and improving stability.

The Typical Characteristics show the recommended R_S vs *Capacitive Load* (Figure 15) and the resulting frequency response at the load. Parasitic capacitive loads greater than 2pF can begin to degrade the performance of the OPA694. Long PCB traces, unmatched cables, and connections to multiple devices can easily cause this value to be exceeded. Always consider this effect carefully, and add the recommended series resistor as close as possible to the OPA694 output pin (see the *Board Layout Guidelines* section).

DISTORTION PERFORMANCE

The OPA694 provides good distortion performance into a 100Ω load on ±5V supplies. Generally, until the fundamental signal reaches very high frequency or power levels, the 2nd-harmonic will dominate the distortion with a negligible 3rd-harmonic component. Focusing then on the 2nd-harmonic, increasing the load impedance improves distortion directly. Remember that the total load includes the feedback network—in the noninverting configuration (see Figure 31), this is the sum of $R_F + R_G$, while in the inverting configuration it is just R_F . Also, providing an additional supply decoupling capacitor (0.1μF) between the supply pins (for bipolar operation) improves the 2nd-order distortion slightly (3dB to 6dB).

In most op amps, increasing the output voltage swing increases harmonic distortion directly. The Typical Characteristics show the 2nd-harmonic increasing at

a little less than the expected 2x rate, while the 3rd-harmonic increases at a little less than the expected 3x rate. Where the test power doubles, the 2nd-harmonic increases by less than the expected 6dB, while the 3rd-harmonic increases by less than the expected 12dB. This also shows up in the two-tone, third-order intermodulation spurious (IM_3) response curves. The 3rd-order spurious levels are extremely low at low output power levels. The output stage continues to hold them low even as the fundamental power reaches very high levels. As the Typical Characteristics show, the spurious intermodulation powers do not increase as predicted by a traditional intercept model. As the fundamental power level increases, the dynamic range does not decrease significantly.

NOISE PERFORMANCE

Wideband, current-feedback op amps generally have a higher output noise than comparable voltage-feedback op amps. The OPA694 offers an excellent balance between voltage and current noise terms to achieve low output noise. The inverting current noise (24pA/√Hz) is significantly lower than earlier solutions, while the input voltage noise (2.1nV/√Hz) is lower than most unity-gain stable, wideband, voltage-feedback op amps. This low input voltage noise was achieved at the price of higher noninverting input current noise (22pA/√Hz). As long as the AC source impedance looking out of the noninverting node is less than 100Ω, this current noise will not contribute significantly to the total output noise. The op amp input voltage noise and the two input current noise terms combine to give low output noise under a wide variety of operating conditions. Figure 40 shows the op amp noise analysis model with all the noise terms included. In this model, all noise terms are taken to be noise voltage or current density terms in either nV/√Hz or pA/√Hz.

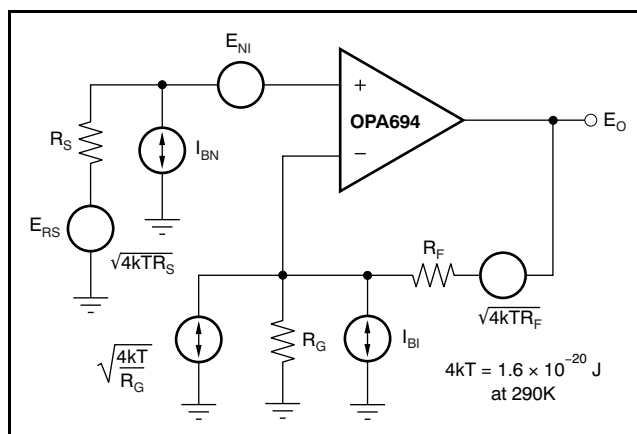

Figure 40. Op Amp Noise Analysis Model

The total output spot noise voltage can be computed as the square root of the sum of all squared output noise voltage contributors. Equation 4 shows the general form for the output noise voltage using the terms shown in Figure 40.

$$E_o = \sqrt{\left(E_{NI}^2 + (I_{BN}R_S)^2 + 4kTR_S \right) NG^2 + (I_{BI}R_F)^2 + 4kTR_F} NG \quad (4)$$

Dividing this expression by the noise gain [NG = (1 + R_F/R_G)] will give the equivalent input-referred spot noise voltage at the noninverting input, as shown in Equation 5.

$$E_N = \sqrt{E_{NI}^2 + (I_{BN}R_S)^2 + 4kTR_S + \left(\frac{I_{BI}R_F}{NG} \right)^2 + \frac{4kTR_F}{NG}} \quad (5)$$

Evaluating these two equations for the OPA694 circuit and component values (see Figure 31) gives a total output spot noise voltage of 11.2nV/√Hz and a total equivalent input spot noise voltage of 5.6nV/√Hz. This total input-referred spot noise voltage is higher than the 2.1nV/√Hz specification for the op amp voltage noise alone. This reflects the noise added to the output by the inverting current noise times the feedback resistor. If the feedback resistor is reduced in high-gain configurations (as suggested previously), the total input-referred voltage noise given by Equation 5 will approach just the 2.1nV/√Hz of the op amp itself. For example, going to a gain of +10 using R_F = 178Ω will give a total input-referred noise of 2.36nV/√Hz.

DC ACCURACY AND OFFSET CONTROL

A current-feedback op amp like the OPA694 provides exceptional bandwidth in high gains, giving fast pulse settling, but only moderate DC accuracy. The Electrical Characteristics show an input offset voltage comparable to high-speed, voltage-feedback amplifiers. However, the two input bias currents are somewhat higher and are unmatched. Whereas bias current cancellation techniques are very effective with most voltage-feedback op amps, they do not generally reduce the output DC offset for wideband, current-feedback op amps. Since the two input bias currents are unrelated in both magnitude and polarity, matching the source impedance looking out of each input to reduce their error contribution to the output is ineffective. Evaluating the configuration of Figure 31, using worst-case +25°C input offset voltage and the two input bias currents, gives a worst-case output offset range equal to:

$$\pm(NG \times V_{OS}) \pm (I_{BN} \times R_S/2 \times NG) \pm (I_{BI} \times R_F)$$

where NG = noninverting signal gain

$$\begin{aligned} &= \pm(2 \times 3\text{mV}) \pm (20\mu\text{A} \times 25\Omega \times 2) \pm (402\Omega \times 18\mu\text{A}) \\ &= \pm 6\text{mV} + 1\text{mV} \pm 7.24\text{mV} = \pm 14.24\text{mV} \end{aligned}$$

A fine-scale, output offset null, or DC operating point adjustment, is sometimes required. Numerous techniques are available for introducing DC offset control into an op amp circuit. Most simple adjustment techniques do not correct for temperature drift. It is possible to combine a lower speed, precision op amp with the OPA694 to get the DC accuracy of the precision op amp along with the signal bandwidth of the OPA694. Figure 41 shows a noninverting G = +10 circuit that holds an output offset voltage less than ±7.5mV over-temperature with > 150MHz signal bandwidth.

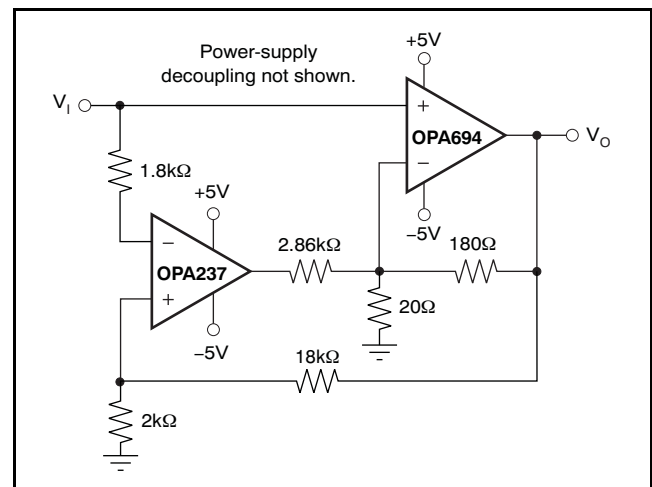

Figure 41. Wideband, DC-Connected Composite Circuit

This DC-coupled circuit provides very high signal bandwidth using the OPA694. At lower frequencies, the output voltage is attenuated by the signal gain and compared to the original input voltage at the inputs of the OPA237 (this is a low-cost, precision voltage-feedback op amp with 1.5MHz gain bandwidth product). If these two do not agree (due to DC offsets introduced by the OPA694), the OPA237 sums in a correction current through the 2.86kΩ inverting summing path. Several design considerations will allow this circuit to be optimized. First, the feedback to the OPA237 noninverting input must be precisely matched to the high-speed signal gain. Making the 2kΩ resistor to ground an adjustable resistor would allow the low- and high-frequency gains to be precisely matched. Second, the crossover frequency region where the OPA237 passes control to the OPA694 must occur with exceptional phase linearity. These two issues reduce to designing for pole/zero cancellation in the overall transfer function. Using the 2.86kΩ resistor will nominally satisfy this

requirement for the circuit in [Figure 41](#). Perfect cancellation over process and temperature is not possible. However, this initial resistor setting and precise gain matching will minimize long-term pulse settling tails.

THERMAL ANALYSIS

Due to the high output power capability of the OPA694, heatsinking or forced airflow may be required under extreme operating conditions. Maximum desired junction temperature will set the maximum allowed internal power dissipation, as described below. In no case should the maximum junction temperature be allowed to exceed +150°C.

Operating junction temperature (T_J) is given by $T_A + P_D \times \theta_{JA}$. The total internal power dissipation (P_D) is the sum of quiescent power (P_{DQ}) and additional power dissipated in the output stage (P_{DL}) to deliver load power. Quiescent power is simply the specified no-load supply current times the total supply voltage across the part. P_{DL} will depend on the required output signal and load but would, for a grounded resistive load, be at a maximum when the output is fixed at a voltage equal to 1/2 either supply voltage (for equal bipolar supplies). Under this condition $P_{DL} = V_S^2 / (4 \times R_L)$ where R_L includes feedback network loading.

Note that it is the power in the output stage and not in the load that determines internal power dissipation.

As a worst-case example, compute the maximum T_J using an OPA694IDBV (SOT23-5 package) in the circuit of [Figure 31](#) operating at the maximum specified ambient temperature of +85°C and driving a grounded 20Ω load to +2.5V DC:

$$P_D = 10V \times 6.0mA + 5^2 / [4 \times (20\Omega \parallel 804\Omega)] = 380mW$$

$$\text{Maximum } T_J = +85^\circ\text{C} + (0.38W \times (150^\circ\text{C}/W)) = 142^\circ\text{C}$$

Although this is still below the specified maximum junction temperature, system reliability considerations may require lower junction temperatures. Remember, this is a worst-case internal power dissipation—use your actual signal and load to compute P_{DL} . The highest possible internal dissipation will occur if the load requires current to be forced into the output for positive output voltages or sourced from the output for negative output voltages. This puts a high current through a large internal voltage drop in the output transistors. The *Output Voltage and Current Limitations* plot ([Figure 21](#)) shown in the Typical Characteristics includes a boundary for 1W maximum internal power dissipation under these conditions.

BOARD LAYOUT GUIDELINES

Achieving optimum performance with a high-frequency amplifier like the OPA694 requires careful attention to board layout parasitics and external component types. Recommendations that will optimize performance include:

a) Minimize parasitic capacitance to any AC ground for all of the signal I/O pins. Parasitic capacitance on the output and inverting input pins can cause instability: on the noninverting input, it can react with the source impedance to cause unintentional bandlimiting. To reduce unwanted capacitance, a window around the signal I/O pins should be opened in all of the ground and power planes around those pins. Otherwise, ground and power planes should be unbroken elsewhere on the board.

b) Minimize the distance (< 0.25in, or 0.635cm) from the power-supply pins to high-frequency 0.1μF decoupling capacitors. At the device pins, the ground and power plane layout should not be in close proximity to the signal I/O pins. Avoid narrow power and ground traces to minimize inductance between the pins and the decoupling capacitors. The power-supply connections (on pins 4 and 7) should always be decoupled with these capacitors. An optional supply decoupling capacitor across the two power supplies (for bipolar operation) will improve 2nd-harmonic distortion performance. Larger (2.2μF to 6.8μF) decoupling capacitors, effective at lower frequencies, should also be used on the main supply pins. These may be placed somewhat farther from the device and may be shared among several devices in the same area of the PCB.

c) Careful selection and placement of external components will preserve the high-frequency performance of the OPA694. Resistors should be a very low reactance type. Surface-mount resistors work best and allow a tighter overall layout. Metal-film and carbon composition, axially-leaded resistors can also provide good high-frequency performance. Again, keep their leads and PCB trace length as short as possible. Never use wirewound type resistors in a high-frequency application. Since the output pin and inverting input pin are the most sensitive to parasitic capacitance, always position the feedback and series output resistor, if any, as close as possible to the output pin. Other network components, such as noninverting input termination resistors, should also be placed close to the package. Where double-side component mounting is allowed, place the feedback resistor directly under the package on the other side of the board between the output and inverting input pins. The frequency response is primarily determined by the feedback resistor value, as described previously. Increasing its value will reduce the bandwidth, while decreasing it will give a more peaked frequency response. The 402Ω feedback

resistor used in the Electrical Characteristic tables at a gain of +2 on $\pm 5V$ supplies is a good starting point for design. Note that a 430Ω feedback resistor, rather than a direct short, is recommended for the unity-gain follower application. A current-feedback op amp requires a feedback resistor even in the unity-gain follower configuration to control stability.

d) Connections to other wideband devices on the board may be made with short, direct traces or through onboard transmission lines. For short connections, consider the trace and the input to the next device as a lumped capacitive load. Relatively wide traces (50mils to 100mils, or 1,270mm to 2,540mm) should be used, preferably with ground and power planes opened up around them. Estimate the total capacitive load and set R_S from the plot of *Recommended R_S vs Capacitive Load* (Figure 15). Low parasitic capacitive loads ($< 5pF$) may not need an R_S , since the OPA694 is nominally compensated to operate with a $2pF$ parasitic load. If a long trace is required, and the 6dB signal loss intrinsic to a doubly-terminated transmission line is acceptable, implement a matched impedance transmission line using microstrip or stripline techniques (consult an ECL design handbook for microstrip and stripline layout techniques). A 50Ω environment is normally not necessary onboard, and in fact, a higher impedance environment will improve distortion, as shown in the *Distortion versus Load* plots. With a characteristic board trace impedance defined based on board material and trace dimensions, a matching series resistor into the trace from the output of the OPA694 is used as well as a terminating shunt resistor at the input of the destination device. Remember also that the terminating impedance will be the parallel combination of the shunt resistor and the input impedance of the destination device: this total effective impedance should be set to match the trace impedance. The high output voltage and current capability of the OPA694 allows multiple destination devices to be handled as separate transmission lines, each with their own series and shunt terminations. If the 6dB attenuation of a doubly-terminated transmission line is unacceptable, a long trace can be series-terminated at the source end only. Treat the

trace as a capacitive load in this case and set the series resistor value as shown in the plot of *Recommended R_S vs Capacitive Load*. This will not preserve signal integrity as well as a doubly-terminated line. If the input impedance of the destination device is low, there will be some signal attenuation due to the voltage divider formed by the series output into the terminating impedance.

e) Socketing a high-speed part like the OPA694 is not recommended. The additional lead length and pin-to-pin capacitance introduced by the socket can create an extremely troublesome parasitic network which can make it almost impossible to achieve a smooth, stable frequency response. Best results are obtained by soldering the OPA694 onto the board.. The additional lead length and pin-to-pin capacitance introduced by the socket can create an extremely troublesome parasitic network which can make it almost impossible to achieve a smooth, stable frequency response. Best results are obtained by soldering the OPA694 onto the board.

INPUT AND ESD PROTECTION

The OPA694 is built using a very high speed complementary bipolar process. The internal junction breakdown voltages are relatively low for these very small geometry devices. These breakdowns are reflected in the *Absolute Maximum Ratings* table. All device pins have limited ESD protection using internal diodes to the power supplies, as shown in Figure 42.

These diodes provide moderate protection to input overdrive voltages above the supplies as well. The protection diodes can typically support 30mA continuous current. Where higher currents are possible (for example, in systems with $\pm 15V$ supply parts driving into the OPA694), current-limiting series resistors should be added into the two inputs. Keep these resistor values as low as possible, since high values degrade both noise performance and frequency response.

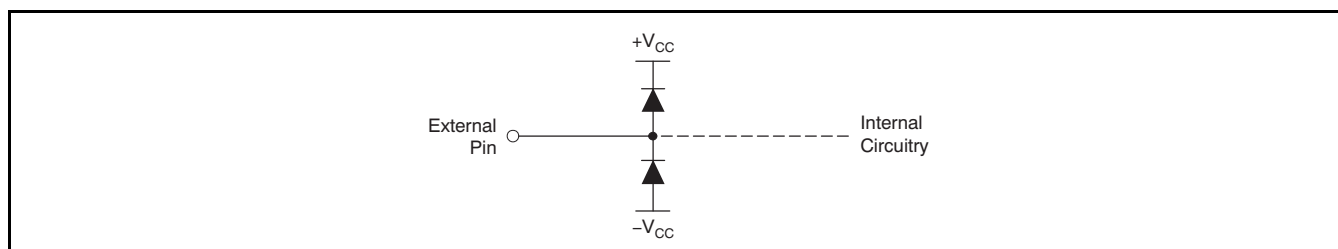

Figure 42. Internal ESD Protection

REVISION HISTORY

NOTE: Page numbers for previous revisions may differ from page numbers in the current version.

Changes from Revision F (August, 2008) to Revision G	Page
• Updated document format to current standards	1
• Deleted <i>lead temperature</i> specifications from Absolute Maximum Ratings table	2
• Revised <i>ADC Driver</i> section to remove references to TI ADS522x devices	10
• Changed Figure 33	11
• Updated Figure 34	11
• Changed Figure 36	12
• Updated Figure 41	16

REVISION HISTORY

Changes from Revision E (March, 2006) to Revision F	Page
• Changed <i>Storage Temperature</i> minimum value from –40°C to –65°C	2

PACKAGING INFORMATION

Orderable Device	Status (1)	Package Type	Package Drawing	Pins	Package Qty	Eco Plan (2)	Lead/Ball Finish (6)	MSL Peak Temp (3)	Op Temp (°C)	Device Marking (4/5)	Samples
OPA694ID	ACTIVE	SOIC	D	8	75	Green (RoHS & no Sb/Br)	CU NIPDAU	Level-2-260C-1 YEAR	-40 to 85	OPA 694	Samples
OPA694IDBVR	ACTIVE	SOT-23	DBV	5	3000	Green (RoHS & no Sb/Br)	CU NIPDAU	Level-1-260C-UNLIM	-40 to 85	BIA	Samples
OPA694IDBVT	ACTIVE	SOT-23	DBV	5	250	Green (RoHS & no Sb/Br)	CU NIPDAU	Level-1-260C-UNLIM	-40 to 85	BIA	Samples
OPA694IDG4	ACTIVE	SOIC	D	8	75	Green (RoHS & no Sb/Br)	CU NIPDAU	Level-2-260C-1 YEAR	-40 to 85	OPA 694	Samples
OPA694IDR	ACTIVE	SOIC	D	8	2500	Green (RoHS & no Sb/Br)	CU NIPDAU	Level-2-260C-1 YEAR	-40 to 85	OPA 694	Samples
OPA694IDRG4	ACTIVE	SOIC	D	8	2500	Green (RoHS & no Sb/Br)	CU NIPDAU	Level-2-260C-1 YEAR	-40 to 85	OPA 694	Samples

(1) The marketing status values are defined as follows:

ACTIVE: Product device recommended for new designs.

LIFEBUY: TI has announced that the device will be discontinued, and a lifetime-buy period is in effect.

NRND: Not recommended for new designs. Device is in production to support existing customers, but TI does not recommend using this part in a new design.

PREVIEW: Device has been announced but is not in production. Samples may or may not be available.

OBSELETE: TI has discontinued the production of the device.

(2) **RoHS:** TI defines "RoHS" to mean semiconductor products that are compliant with the current EU RoHS requirements for all 10 RoHS substances, including the requirement that RoHS substance do not exceed 0.1% by weight in homogeneous materials. Where designed to be soldered at high temperatures, "RoHS" products are suitable for use in specified lead-free processes. TI may reference these types of products as "Pb-Free".

RoHS Exempt: TI defines "RoHS Exempt" to mean products that contain lead but are compliant with EU RoHS pursuant to a specific EU RoHS exemption.

Green: TI defines "Green" to mean the content of Chlorine (Cl) and Bromine (Br) based flame retardants meet JS709B low halogen requirements of <=1000ppm threshold. Antimony trioxide based flame retardants must also meet the <=1000ppm threshold requirement.

(3) MSL, Peak Temp. - The Moisture Sensitivity Level rating according to the JEDEC industry standard classifications, and peak solder temperature.

(4) There may be additional marking, which relates to the logo, the lot trace code information, or the environmental category on the device.

(5) Multiple Device Markings will be inside parentheses. Only one Device Marking contained in parentheses and separated by a "~" will appear on a device. If a line is indented then it is a continuation of the previous line and the two combined represent the entire Device Marking for that device.

⁽⁶⁾ Lead/Ball Finish - Orderable Devices may have multiple material finish options. Finish options are separated by a vertical ruled line. Lead/Ball Finish values may wrap to two lines if the finish value exceeds the maximum column width.

Important Information and Disclaimer:The information provided on this page represents TI's knowledge and belief as of the date that it is provided. TI bases its knowledge and belief on information provided by third parties, and makes no representation or warranty as to the accuracy of such information. Efforts are underway to better integrate information from third parties. TI has taken and continues to take reasonable steps to provide representative and accurate information but may not have conducted destructive testing or chemical analysis on incoming materials and chemicals. TI and TI suppliers consider certain information to be proprietary, and thus CAS numbers and other limited information may not be available for release.

In no event shall TI's liability arising out of such information exceed the total purchase price of the TI part(s) at issue in this document sold by TI to Customer on an annual basis.

TAPE AND REEL INFORMATION



QUADRANT ASSIGNMENTS FOR PIN 1 ORIENTATION IN TAPE



*All dimensions are nominal

Device	Package Type	Package Drawing	Pins	SPQ	Reel Diameter (mm)	Reel Width W1 (mm)	A0 (mm)	B0 (mm)	K0 (mm)	P1 (mm)	W (mm)	Pin1 Quadrant
OPA694IDR	SOIC	D	8	2500	330.0	12.4	6.4	5.2	2.1	8.0	12.0	Q1

TAPE AND REEL BOX DIMENSIONS



*All dimensions are nominal

Device	Package Type	Package Drawing	Pins	SPQ	Length (mm)	Width (mm)	Height (mm)
OPA694IDR	SOIC	D	8	2500	367.0	367.0	35.0



D0008A

PACKAGE OUTLINE

SOIC - 1.75 mm max height

SMALL OUTLINE INTEGRATED CIRCUIT



4214825/C 02/2019

NOTES:

1. Linear dimensions are in inches [millimeters]. Dimensions in parenthesis are for reference only. Controlling dimensions are in inches. Dimensioning and tolerancing per ASME Y14.5M.
2. This drawing is subject to change without notice.
3. This dimension does not include mold flash, protrusions, or gate burrs. Mold flash, protrusions, or gate burrs shall not exceed $.006$ [0.15] per side.
4. This dimension does not include interlead flash.
5. Reference JEDEC registration MS-012, variation AA.

EXAMPLE BOARD LAYOUT

D0008A

SOIC - 1.75 mm max height

SMALL OUTLINE INTEGRATED CIRCUIT



LAND PATTERN EXAMPLE
 EXPOSED METAL SHOWN
 SCALE:8X



SOLDER MASK DETAILS

4214825/C 02/2019

NOTES: (continued)

- 6. Publication IPC-7351 may have alternate designs.
- 7. Solder mask tolerances between and around signal pads can vary based on board fabrication site.

EXAMPLE STENCIL DESIGN

D0008A

SOIC - 1.75 mm max height

SMALL OUTLINE INTEGRATED CIRCUIT



SOLDER PASTE EXAMPLE
BASED ON .005 INCH [0.125 MM] THICK STENCIL
SCALE:8X

4214825/C 02/2019

NOTES: (continued)

8. Laser cutting apertures with trapezoidal walls and rounded corners may offer better paste release. IPC-7525 may have alternate design recommendations.
9. Board assembly site may have different recommendations for stencil design.

EXAMPLE BOARD LAYOUT

DBV0005A

SOT-23 - 1.45 mm max height

SMALL OUTLINE TRANSISTOR



LAND PATTERN EXAMPLE
EXPOSED METAL SHOWN
SCALE:15X



SOLDER MASK DETAILS

4214839/D 11/2018

NOTES: (continued)

- 5. Publication IPC-7351 may have alternate designs.
- 6. Solder mask tolerances between and around signal pads can vary based on board fabrication site.

EXAMPLE STENCIL DESIGN

DBV0005A

SOT-23 - 1.45 mm max height

SMALL OUTLINE TRANSISTOR



SOLDER PASTE EXAMPLE
BASED ON 0.125 mm THICK STENCIL
SCALE:15X

4214839/D 11/2018

NOTES: (continued)

7. Laser cutting apertures with trapezoidal walls and rounded corners may offer better paste release. IPC-7525 may have alternate design recommendations.
8. Board assembly site may have different recommendations for stencil design.

IMPORTANT NOTICE AND DISCLAIMER

TI PROVIDES TECHNICAL AND RELIABILITY DATA (INCLUDING DATASHEETS), DESIGN RESOURCES (INCLUDING REFERENCE DESIGNS), APPLICATION OR OTHER DESIGN ADVICE, WEB TOOLS, SAFETY INFORMATION, AND OTHER RESOURCES "AS IS" AND WITH ALL FAULTS, AND DISCLAIMS ALL WARRANTIES, EXPRESS AND IMPLIED, INCLUDING WITHOUT LIMITATION ANY IMPLIED WARRANTIES OF MERCHANTABILITY, FITNESS FOR A PARTICULAR PURPOSE OR NON-INFRINGEMENT OF THIRD PARTY INTELLECTUAL PROPERTY RIGHTS.

These resources are intended for skilled developers designing with TI products. You are solely responsible for (1) selecting the appropriate TI products for your application, (2) designing, validating and testing your application, and (3) ensuring your application meets applicable standards, and any other safety, security, or other requirements. These resources are subject to change without notice. TI grants you permission to use these resources only for development of an application that uses the TI products described in the resource. Other reproduction and display of these resources is prohibited. No license is granted to any other TI intellectual property right or to any third party intellectual property right. TI disclaims responsibility for, and you will fully indemnify TI and its representatives against, any claims, damages, costs, losses, and liabilities arising out of your use of these resources.

TI's products are provided subject to TI's Terms of Sale (www.ti.com/legal/termsofsale.html) or other applicable terms available either on ti.com or provided in conjunction with such TI products. TI's provision of these resources does not expand or otherwise alter TI's applicable warranties or warranty disclaimers for TI products.

Mailing Address: Texas Instruments, Post Office Box 655303, Dallas, Texas 75265
Copyright © 2019, Texas Instruments Incorporated

Looking for pricing, stock, or lifecycle information?

Click below to explore more details on WIN SOURCE:

 [View OPA694IDBVR](#) on WIN SOURCE

 [Texas Instruments](#) Information

Optimize Your Supply Chain with WIN SOURCE Solutions

-  Global Sourcing Solution
-  Obsolete Management
-  Cost Control Management
-  Shortage Management
-  Alternative Solution
-  Excess Inventory Management