



**THE DATASHEET OF  
AD670KN**



### FEATURES

- Complete 8-Bit Signal Conditioning A/D Converter Including Instrumentation Amp and Reference Microprocessor Bus Interface**
- 10  $\mu$ s Conversion Speed**
- Flexible Input Stage: Instrumentation Amp Front End Provides Differential Inputs and High Common-Mode Rejection**
- No User Trims Required**
- No Missing Codes Over Temperature**
- Single +5 V Supply Operation**
- Convenient Input Ranges**
- 20-Pin DIP or Surface-Mount Package**
- Low Cost Monolithic Construction**
- MIL-STD-883B Compliant Versions Available**

### GENERAL DESCRIPTION

The AD670 is a complete 8-bit signal conditioning analog-to-digital converter. It consists of an instrumentation amplifier front end along with a DAC, comparator, successive approximation register (SAR), precision voltage reference, and a three-state output buffer on a single monolithic chip. No external components or user trims are required to interface, with full accuracy, an analog system to an 8-bit data bus. The AD670 will operate on the +5 V system supply. The input stage provides differential inputs with excellent common-mode rejection and allows direct interface to a variety of transducers.

The device is configured with input scaling resistors to permit two input ranges: 0 mV to 255 mV (1 mV/LSB) and 0 to 2.55 V (10 mV/LSB). The AD670 can be configured for both unipolar and bipolar inputs over these ranges. The differential inputs and common-mode rejection of this front end are useful in applications such as conversion of transducer signals superimposed on common-mode voltages.

The AD670 incorporates advanced circuit design and proven processing technology. The successive approximation function is implemented with I<sup>2</sup>L (integrated injection logic). Thin-film SiCr resistors provide the stability required to prevent missing codes over the entire operating temperature range while laser wafer trimming of the resistor ladder permits calibration of the device to within  $\pm 1$  LSB. Thus, no user trims for gain or offset are required. Conversion time of the device is 10  $\mu$ s.

The AD670 is available in four package types and five grades. The J and K grades are specified over 0°C to +70°C and come in 20-pin plastic DIP packages or 20-terminal PLCC packages. The A and B grades (-40°C to +85°C) and the S grade (-55°C to +125°C) come in 20-pin ceramic DIP packages.

### REV. A

Information furnished by Analog Devices is believed to be accurate and reliable. However, no responsibility is assumed by Analog Devices for its use, nor for any infringements of patents or other rights of third parties which may result from its use. No license is granted by implication or otherwise under any patent or patent rights of Analog Devices.

### FUNCTIONAL BLOCK DIAGRAM

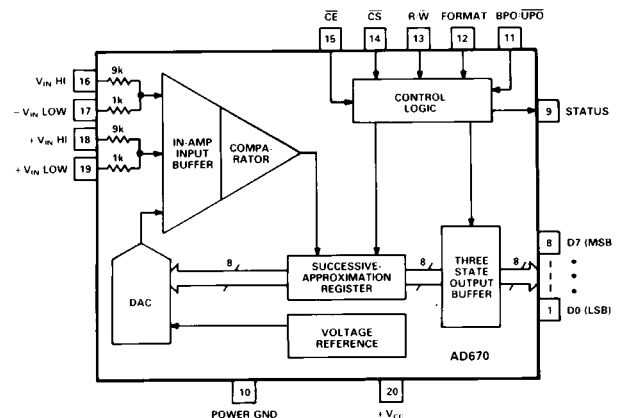

The S grade is also available with optional processing to MIL-STD-883 in 20-pin ceramic DIP or 20-terminal LCC packages. The Analog Devices Military Products Databook should be consulted for detailed specifications.

### PRODUCT HIGHLIGHTS

1. The AD670 is a complete 8-bit A/D including three-state outputs and microprocessor control for direct connection to 8-bit data buses. No external components are required to perform a conversion.
2. The flexible input stage features a differential instrumentation amp input with excellent common-mode rejection. This allows direct interface to a variety of transducers without preamplification.
3. No user trims are required for 8-bit accurate performance.
4. Operation from a single +5 V supply allows the AD670 to run off of the microprocessor's supply.
5. Four convenient input ranges (two unipolar and two bipolar) are available through internal scaling resistors: 0 mV to 255 mV (1 mV/LSB) and 0 V to 2.55 V (10 mV/LSB).
6. Software control of the output mode is provided. The user can easily select unipolar or bipolar inputs and binary or 2s complement output codes.

# AD670—SPECIFICATIONS (@ $V_{CC} = +5\text{ V}$ and $+25^\circ\text{C}$ , unless otherwise noted)

| Model  | AD670J  |           |                              | AD670K |           |                              | Units            |
|--|---|-----------|------------------------------|--------|-----------|------------------------------|------------------|
|  | Min   | Typ       | Max                          | Min    | Typ       | Max                          |                  |
| OPERATING TEMPERATURE RANGE  | 0   |           | +70                          | 0      |           | +70                          | $^\circ\text{C}$ |
| RESOLUTION   | 8   |           |                              | 8      |           |                              | Bit              |
| CONVERSION TIME  |   |           | 10                           |        |           | 10                           | $\mu\text{s}$    |
| RELATIVE ACCURACY<br>$T_{\text{MIN}}$ to $T_{\text{MAX}}$                                  |   |           | $\pm 1/2$<br>$\pm 1/2$       |        |           | $\pm 1/4$<br>$\pm 1/2$       | LSB<br>LSB       |
| DIFFERENTIAL LINEARITY ERROR <sup>1</sup><br>$T_{\text{MIN}}$ to $T_{\text{MAX}}$          | <b>GUARANTEED NO MISSING CODES ALL GRADES</b> |           |                              |        |           |                              |                  |
| GAIN ACCURACY<br>@ $+25^\circ\text{C}$<br>$T_{\text{MIN}}$ to $T_{\text{MAX}}$             |   |           | $\pm 1.5$<br>$\pm 2.0$       |        |           | $\pm 0.75$<br>$\pm 1.0$      | LSB<br>LSB       |
| UNIPOLAR ZERO ERROR<br>@ $+25^\circ\text{C}$<br>$T_{\text{MIN}}$ to $T_{\text{MAX}}$       |   |           | $\pm 1.5$<br>$\pm 2.0$       |        |           | $\pm 0.75$<br>$\pm 1.0$      | LSB<br>LSB       |
| BIPOLAR ZERO ERROR<br>@ $+25^\circ\text{C}$<br>$T_{\text{MIN}}$ to $T_{\text{MAX}}$        |   |           | $\pm 1.5$<br>$\pm 2.0$       |        |           | $\pm 0.75$<br>$\pm 1.0$      | LSB<br>LSB       |
| ANALOG INPUT RANGES  |   |           |                              |        |           |                              |                  |
| DIFFERENTIAL ( $-V_{\text{IN}}$ to $+V_{\text{IN}}$ )                                      |   |           |                              |        |           |                              |                  |
| Low Range  |   |           | 0 to +255<br>-128 to +127    |        |           | 0 to +255<br>-128 to +127    | mV<br>mV         |
| High Range   |   |           | 0 to +2.55<br>-1.28 to +1.27 |        |           | 0 to +2.55<br>-1.28 to +1.27 | V<br>V           |
| ABSOLUTE (Inputs to Power GND)   |   |           |                              |        |           |                              |                  |
| Low Range $T_{\text{MIN}}$ to $T_{\text{MAX}}$   | -0.150  |           | $V_{CC} - 3.4$               | -0.150 |           | $V_{CC} - 3.4$               | V                |
| High Range $T_{\text{MIN}}$ to $T_{\text{MAX}}$  | -1.50   |           | $V_{CC}$                     | -1.50  |           | $V_{CC}$                     | V                |
| BIAS CURRENT (255 mV RANGE)<br>$T_{\text{MIN}}$ to $T_{\text{MAX}}$                        |   | 200       | 500                          |        | 200       | 500                          | nA               |
| OFFSET CURRENT (255 mV RANGE)<br>$T_{\text{MIN}}$ to $T_{\text{MAX}}$                      |   | 40        | 200                          |        | 40        | 200                          | nA               |
| 2.55 V RANGE INPUT RESISTANCE  | 8.0   |           | 12.0                         | 8.0    |           | 12.0                         | k $\Omega$       |
| 2.55 V RANGE FULL-SCALE MATCH<br>+ AND - INPUT   |   | $\pm 1/2$ |                              |        | $\pm 1/2$ |                              | LSB              |
| COMMON-MODE REJECTION<br>RATIO (255 mV RANGE)  |   |           | 1                            |        |           | 1                            | LSB              |
| COMMON-MODE REJECTION<br>RATIO (2.55 V RANGE)  |   |           | 1                            |        |           | 1                            | LSB              |
| POWER SUPPLY   |   |           |                              |        |           |                              |                  |
| Operating Range  | 4.5   |           | 5.5                          | 4.5    |           | 5.5                          | V                |
| Current $I_{CC}$   |   | 30        | 45                           |        | 30        | 45                           | mA               |
| Rejection Ratio $T_{\text{MIN}}$ to $T_{\text{MAX}}$                                       |   |           | 0.015                        |        |           | 0.015                        | % of FS/%        |
| DIGITAL OUTPUTS  |   |           |                              |        |           |                              |                  |
| SINK CURRENT ( $V_{\text{OUT}} = 0.4\text{ V}$ )<br>$T_{\text{MIN}}$ to $T_{\text{MAX}}$   | 1.6   |           |                              | 1.6    |           |                              | mA               |
| SOURCE CURRENT ( $V_{\text{OUT}} = 2.4\text{ V}$ )<br>$T_{\text{MIN}}$ to $T_{\text{MAX}}$ | 0.5   |           |                              | 0.5    |           |                              | mA               |
| THREE-STATE LEAKAGE CURRENT  |   |           | $\pm 40$                     |        |           | $\pm 40$                     | $\mu\text{A}$    |
| OUTPUT CAPACITANCE   |   | 5         |                              |        | 5         |                              | pF               |
| DIGITAL INPUT VOLTAGE  |   |           |                              |        |           |                              |                  |
| $V_{\text{INL}}$   |   |           | 0.8                          |        |           | 0.8                          | V                |
| $V_{\text{INH}}$   | 2.0   |           |                              | 2.0    |           |                              | V                |
| DIGITAL INPUT CURRENT<br>( $0 \leq V_{\text{IN}} \leq +5\text{ V}$ )                       |   |           |                              |        |           |                              |                  |
| $I_{\text{INL}}$   | -100  |           |                              | -100   |           |                              | $\mu\text{A}$    |
| $I_{\text{INH}}$   |   |           | +100                         |        |           | +100                         | $\mu\text{A}$    |
| INPUT CAPACITANCE  |   | 10        |                              |        | 10        |                              | pF               |

## NOTES

<sup>1</sup>Tested at  $V_{CC} = 4.5\text{ V}$ ,  $5.0\text{ V}$  and  $5.5\text{ V}$ .

Specifications shown in **boldface** are tested on all production units at final electrical test. Results from those tests are used to calculate outgoing quality levels. All min and max specifications are guaranteed although only those shown in boldface are tested on all production units.

Specifications subject to change without notice.

| Model   | AD670A  |     |   | AD670B |     |   | AD670S |     |   | Units                |
|---|---|-----|---|--------|-----|---|--------|-----|---|----------------------|
|   | Min   | Typ | Max   | Min    | Typ | Max   | Min    | Typ | Max   |                      |
| OPERATING TEMPERATURE RANGE   | -40   |     | +85   | -40    |     | +85   | -55    |     | +125  | °C                   |
| RESOLUTION  |   | 8   |   |        | 8   |   |        | 8   |   | Bit                  |
| CONVERSION TIME   |   |     | 10  |        |     | 10  |        |     | 10  | µs                   |
| RELATIVE ACCURACY<br>T <sub>MIN</sub> to T <sub>MAX</sub>   |   |     | ±1/2<br>±1/2  |        |     | ±1/4<br>±1/2  |        |     | ±1/2<br>±1  | LSB<br>LSB           |
| DIFFERENTIAL LINEARITY ERROR <sup>1</sup><br>T <sub>MIN</sub> to T <sub>MAX</sub>   | <b>GUARANTEED NO MISSING CODES ALL GRADES</b> |     |   |        |     |   |        |     |   |                      |
| GAIN ACCURACY<br>@ +25°C<br>T <sub>MIN</sub> to T <sub>MAX</sub>  |   |     | ±1.5<br>±2.5  |        |     | ±0.75<br>±1.5   |        |     | ±1.5<br>±2.5  | LSB<br>LSB           |
| UNIPOLAR ZERO ERROR<br>@ +25°C<br>T <sub>MIN</sub> to T <sub>MAX</sub>  |   |     | ±1.0<br>±2.0  |        |     | ±0.5<br>±1.0  |        |     | ±1.0<br>±2.0  | LSB<br>LSB           |
| BIPOLAR ZERO ERROR<br>@ +25°C<br>T <sub>MIN</sub> to T <sub>MAX</sub>   |   |     | ±1.0<br>±2.0  |        |     | ±0.5<br>±1.0  |        |     | ±1.0<br>±2.0  | LSB<br>LSB           |
| ANALOG INPUT RANGES<br>DIFFERENTIAL (-V <sub>IN</sub> to +V <sub>IN</sub> )<br>Low Range<br>High Range<br><br>ABSOLUTE (Inputs to Power GND)<br>Low Range T <sub>MIN</sub> to T <sub>MAX</sub><br>High Range T <sub>MIN</sub> to T <sub>MAX</sub> |   |     | 0 to +255<br>-128 to +127<br>0 to +2.55<br>-1.28 to +1.27 |        |     | 0 to +255<br>-128 to +127<br>0 to +2.55<br>-1.28 to +1.27 |        |     | 0 to +255<br>-128 to +127<br>0 to +2.55<br>-1.28 to +1.27 | mV<br>mV<br>V<br>V   |
| BIAS CURRENT (255 mV RANGE)<br>T <sub>MIN</sub> to T <sub>MAX</sub>   |   | 200 | 500   |        | 200 | 500   |        | 200 | 750   | nA                   |
| OFFSET CURRENT (255 mV RANGE)<br>T <sub>MIN</sub> to T <sub>MAX</sub>   |   | 40  | 200   |        | 40  | 200   |        | 40  | 200   | nA                   |
| 2.55 V RANGE INPUT RESISTANCE   | 8.0   |     | 12.0  | 8.0    |     | 12.0  | 8.0    |     | 12.0  | kΩ                   |
| 2.55 V RANGE FULL-SCALE MATCH<br>+ AND - INPUT  |   |     | ±1/2  |        |     | ±1/2  |        |     | ±1/2  | LSB                  |
| COMMON-MODE REJECTION<br>RATIO (255 mV RANGE)   |   |     | 1   |        |     | 1   |        |     | 1   | LSB                  |
| COMMON-MODE REJECTION<br>RATIO (2.55 V RANGE)   |   |     | 1   |        |     | 1   |        |     | 1   | LSB                  |
| POWER SUPPLY<br>Operating Range<br>Current I <sub>CC</sub><br>Rejection Ratio T <sub>MIN</sub> to T <sub>MAX</sub>  | 4.5   |     | 5.5   | 4.5    |     | 5.5   | 4.75   |     | 5.5   | V<br>mA<br>% of FS/% |
| DIGITAL OUTPUTS<br>SINK CURRENT (V <sub>OUT</sub> = 0.4 V)<br>T <sub>MIN</sub> to T <sub>MAX</sub><br>SOURCE CURRENT (V <sub>OUT</sub> = 2.4 V)<br>T <sub>MIN</sub> to T <sub>MAX</sub>   | 1.6   |     |   | 1.6    |     |   | 1.6    |     |   | mA<br>mA             |
| THREE-STATE LEAKAGE CURRENT   |   |     | ±40   |        |     | ±40   |        |     | ±40   | µA                   |
| OUTPUT CAPACITANCE  |   | 5   |   |        | 5   |   |        | 5   |   | pF                   |
| DIGITAL INPUT VOLTAGE<br>V <sub>INL</sub><br>V <sub>INH</sub>   | 2.0   |     | 0.8   | 2.0    |     | 0.8   | 2.0    |     | 0.7   | V<br>V               |
| DIGITAL INPUT CURRENT<br>(0 ≤ V <sub>IN</sub> ≤ +5 V)<br>I <sub>INL</sub><br>I <sub>INH</sub>   | -100  |     | +100  | -100   |     | +100  | -100   |     | +100  | µA<br>µA             |
| INPUT CAPACITANCE   |   | 10  |   |        | 10  |   |        | 10  |   | pF                   |

## NOTES

<sup>1</sup>Tested at V<sub>CC</sub> = 4.5 V, 5.0 V and 5.5 V for A, B grades; 4.75 V, 5.0 V and 5.5 V for S grade.

Specifications shown in **boldface** are tested on all production units at final electrical test. Results from those tests are used to calculate outgoing quality levels. All min and max specifications are guaranteed, although only those shown in boldface are tested on all production units.

Specifications subject to change without notice.

# AD670

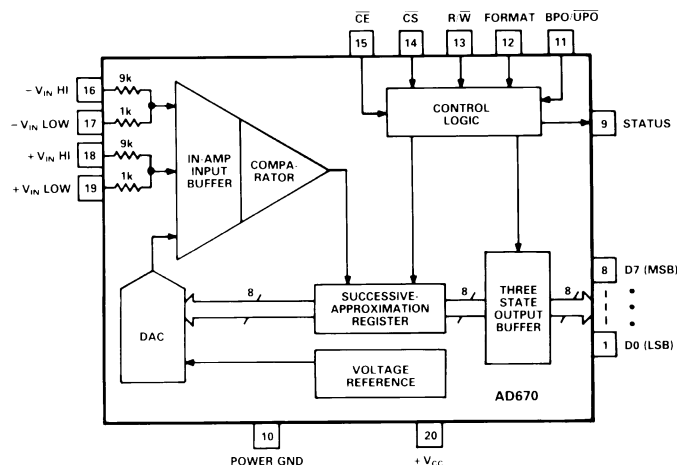

Figure 1. AD670 Block Diagram and Terminal Configuration (All Packages)

## ABSOLUTE MAXIMUM RATINGS\*

|                                      |                                       |
|--------------------------------------|---------------------------------------|
| $V_{CC}$ to Ground                   | 0 V to +7.5 V                         |
| Digital Inputs (Pins 11–15)          | –0.5 V to $V_{CC}$ +0.5 V             |
| Digital Outputs (Pins 1–9)           | Momentary Short to $V_{CC}$ or Ground |
| Analog Inputs (Pins 16–19)           | –30 V to +30 V                        |
| Power Dissipation                    | 450 mW                                |
| Storage Temperature Range            | –65°C to +150°C                       |
| Lead Temperature (Soldering, 10 sec) | +300°C                                |

\*Stresses above those listed under “Absolute Maximum Ratings” may cause permanent damage to the device. This is a stress rating only and functional operation of the device at them or any other conditions above those indicated in the operational sections of this specification is not implied. Exposure to absolute maximum rating conditions for extended periods may affect device reliability.

## ORDERING GUIDE

| Model <sup>1</sup> | Temperature Range | Relative Accuracy @ +25°C | Gain Accuracy @ +25°C | Package Option <sup>2</sup> |
|--------------------|-------------------|---------------------------|-----------------------|-----------------------------|
| AD670JN            | 0°C to +70°C      | ±1/2 LSB                  | ±1.5 LSB              | Plastic DIP (N-20)          |
| AD670JP            | 0°C to +70°C      | ±1/2 LSB                  | ±1.5 LSB              | PLCC (P-20A)                |
| AD670KN            | 0°C to +70°C      | ±1/4 LSB                  | ±0.75 LSB             | Plastic DIP (N-20)          |
| AD670KP            | 0°C to +70°C      | ±1/4 LSB                  | ±0.75 LSB             | PLCC (P-20A)                |
| AD670AD            | –40°C to +85°C    | ±1/2 LSB                  | ±1.5 LSB              | Ceramic DIP (D-20)          |
| AD670BD            | –40°C to +85°C    | ±1/4 LSB                  | ±0.75 LSB             | Ceramic DIP (D-20)          |
| AD670SD            | –55°C to +125°C   | ±1/2 LSB                  | ±1.5 LSB              | Ceramic DIP (D-20)          |

### NOTES

<sup>1</sup>For details on grade and package offerings screened in accordance with MIL-STD-883 refer to the Analog Devices Military Products Databook.

<sup>2</sup>D = Ceramic DIP; N = Plastic DIP; P = Plastic Leaded Chip Carrier.

## CIRCUIT OPERATION/FUNCTIONAL DESCRIPTION

The AD670 is a functionally complete 8-bit signal conditioning A/D converter with microprocessor compatibility. The input section uses an instrumentation amplifier to accomplish the voltage to current conversion. This front end provides a high impedance, low bias current differential amplifier. The common-mode range allows the user to directly interface the device to a variety of transducers.

The A/D conversions are controlled by  $\overline{R/\overline{W}}$ ,  $\overline{CS}$ , and  $\overline{CE}$ . The  $\overline{R/\overline{W}}$  line directs the converter to read or start a conversion. A minimum write/start pulse of 300 ns is required on either  $\overline{CE}$  or  $\overline{CS}$ . The STATUS line goes high, indicating that a conversion is in process. The conversion thus begun, the internal 8-bit DAC is sequenced from MSB to LSB using a novel successive approximation technique. In conventional designs, the DAC is stepped through the bits by a clock. This can be thought of as a static design since the speed at which the DAC is sequenced is determined solely by the clock. No clock is used in the AD670. Instead, a “dynamic SAR” is created consisting of a string of inverters with taps along the delay line. Sections of the delay line between taps act as one shots. The pulses are used to set and reset the DAC’s bits and strobe the comparator. When strobed, the comparator then determines whether the addition of each successively weighted bit current causes the DAC current sum to be greater or less than the input current. If the sum is less, the bit is turned off. After all bits are tested, the SAR holds an 8-bit code representing the input signal to within 1/2 LSB

accuracy. Ease of implementation and reduced dependence on process related variables make this an attractive approach to a successive approximation design.

The SAR provides an end-of-conversion signal to the control logic which then brings the STATUS line low. Data outputs remain in a high impedance state until  $\overline{R/\overline{W}}$  is brought high with  $\overline{CE}$  and  $\overline{CS}$  low and allows the converter to be read. Bringing  $\overline{CE}$  or  $\overline{CS}$  high during the valid data period ends the read cycle. The output buffers cannot be enabled during a conversion. Any convert start commands will be ignored until the conversion cycle is completed; once a conversion cycle has been started it cannot be stopped or restarted.

The AD670 provides the user with a great deal of flexibility by offering two input spans and formats and a choice of output codes. Input format and input range can each be selected. The BPO/ $\overline{UPO}$  pin controls a switch which injects a bipolar offset current of a value equal to the MSB less 1/2 LSB into the summing node of the comparator to offset the DAC output. Two precision 10 to 1 attenuators are included on board to provide input range selection of 0 V to 2.55 V or 0 mV to 255 mV. Additional ranges of –1.28 V to 1.27 V and –128 mV to 127 mV are possible if the BPO/ $\overline{UPO}$  switch is high when the conversion is started. Finally, output coding can be chosen using the FORMAT pin when the conversion is started. In the bipolar mode and with a Logic 1 on FORMAT, the output is in two’s complement; with a Logic 0, the output is offset binary.

### CONNECTING THE AD670

The AD670 has been designed for ease of use. All active components required to perform a complete A/D conversion are on board and are connected internally. In addition, all calibration trims are performed at the factory, assuring specified accuracy without user trims. There are, however, a number of options and connections that should be considered to obtain maximum flexibility from the part.

### INPUT CONNECTIONS

Standard connections are shown in the figures that follow. An input range of 0 V to 2.55 V may be configured as shown in Figure 2a. This will provide a one LSB change for each 10 mV of input change. The input range of 0 mV to 255 mV is configured as shown in Figure 2b. In this case, each LSB represents 1 mV of input change. When unipolar input signals are used, Pin 11, BPO/ $\overline{\text{UPO}}$ , should be grounded. Pin 11 selects the input format for either unipolar or bipolar signals. Figures 3a and 3b show the input connections for bipolar signals. Pin 11 should be tied to  $+V_{CC}$  for bipolar inputs.

Although the instrumentation amplifier has a differential input, there must be a return path to ground for the bias currents. If it is not provided, these currents will charge stray capacitances and cause internal circuit nodes to drift uncontrollably causing the digital output to change. Such a return path is provided in Figures 2a and 3a (larger input ranges) since the 1k resistor leg is tied to ground. This is not the case for Figures 2b and 3b (the lower input ranges). When connecting the AD670 inputs to floating sources, such as transformers and ac-coupled sources, there must still be a dc path from each input to common. This can be accomplished by connecting a 10 k $\Omega$  resistor from each input to ground.

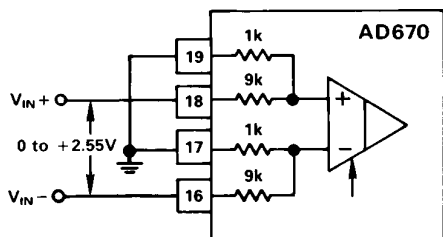

2a. 0 V to 2.55 V (10 mV/LSB)

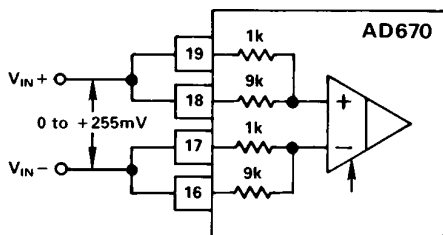

2b. 0 mV to 255 mV (1 mV/LSB)

NOTE: PIN 11, BPO/ $\overline{\text{UPO}}$  SHOULD BE LOW WHEN CONVERSION IS STARTED.

Figure 2. Unipolar Input Connections

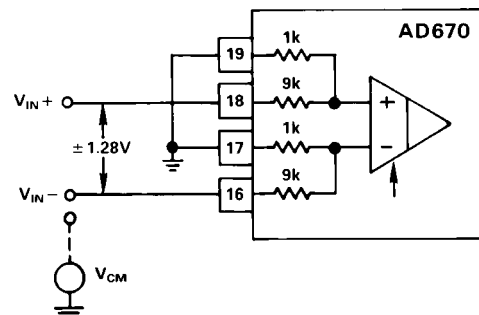

3a.  $\pm 1.28$  V Range

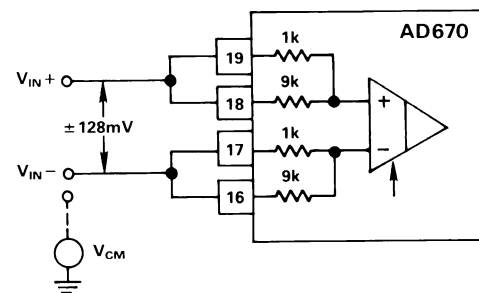

3b.  $\pm 128$  mV Range

NOTE: PIN 11, BPO/ $\overline{\text{UPO}}$  SHOULD BE HIGH WHEN CONVERSION IS STARTED.

Figure 3. Bipolar Input Connections

### Bipolar Operation

Through special design of the instrumentation amplifier, the AD670 accommodates input signal excursions below ground, even though it operates from a single 5 V supply. To the user, this means that true bipolar input signals can be used without the need for any additional external components. Bipolar signals can be applied differentially across both inputs, or one of the inputs can be grounded and a bipolar signal applied to the other.

### Common-Mode Performance

The AD670 is designed to reject dc and ac common-mode voltages. In some applications it is useful to apply a differential input signal  $V_{IN}$  in the presence of a dc common-mode voltage  $V_{CM}$ . The user must observe the absolute input signal limits listed in the specifications, which represent the maximum voltage  $V_{IN} + V_{CM}$  that can be applied to either input without affecting proper operation. Exceeding these limits (within the range of absolute maximum ratings), however, will not cause permanent damage.

The excellent common-mode rejection of the AD670 is due to the instrumentation amplifier front end, which maintains the differential signal until it reaches the output of the comparator. In contrast to a standard operational amplifier, the instrumentation amplifier front end provides significantly improved CMRR over a wide frequency range (Figure 4a).

# AD670

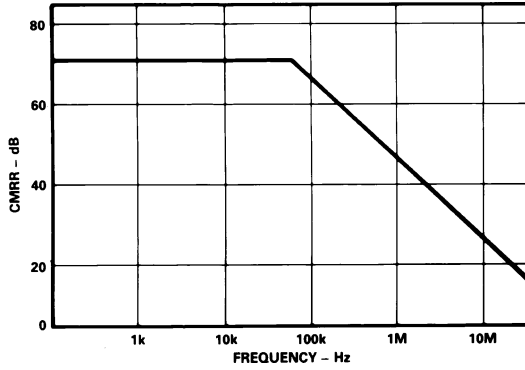

Figure 4a. CMRR Over Frequency

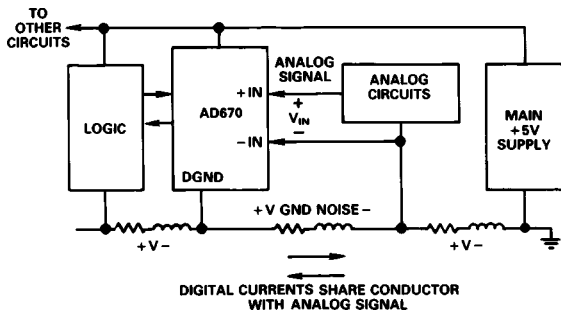

Figure 4b. AD670 Input Rejects Common-Mode Ground Noise

Good common-mode performance is useful in a number of situations. In bridge-type transducer applications, such performance facilitates the recovery of differential analog signals in the presence of a dc common-mode or a noisy electrical environment. High frequency CMRR also becomes important when the analog signal is referred to a noisy, remote digital ground. In each case, the CMRR specification of the AD670 allows the integrity of the input signal to be preserved.

The AD670's common-mode voltage tolerance allows great flexibility in circuit layout. Most other A/D converters require the establishment of one point as the analog reference point. This is necessary in order to minimize the effects of parasitic voltages. The AD670, however, eliminates the need to make the analog ground reference point and A/D analog ground one and the same. Instead, a system such as that shown in Figure 4b is possible as a result of the AD670's common-mode performance. The resistors and inductors in the ground return represent unavoidable system parasitic impedances.

### Input/Output Options

Data output coding (2s complement vs. straight binary) is selected using Pin 12, the FORMAT pin. The selection of input format (bipolar vs. unipolar) is controlled using Pin 11, BPO/UPO. Prior to a write/convert, the state of FORMAT and BPO/UPO should be available to the converter. These lines may be tied to the data bus and may be changed with each conversion if desired. The configurations are shown in Table I. Output coding for representative signals in each of these configurations is shown in Figure 5.

An output signal, STATUS, indicates the status of the conversion. STATUS goes high at the beginning of the conversion and returns low when the conversion cycle has been completed.

Table I. AD670 Input Selection/Output Format Truth Table

| BPO/UPO | FORMAT | INPUT RANGE/<br>OUTPUT FORMAT |
|---------|--------|-------------------------------|
| 0       | 0      | Unipolar/Straight Binary      |
| 1       | 0      | Bipolar/Offset Binary         |
| 0       | 1      | Unipolar/2s Complement        |
| 1       | 1      | Bipolar/2s Complement         |

| +V <sub>IN</sub> | -V <sub>IN</sub> | DIFF<br>V <sub>IN</sub> | STRAIGHT BINARY<br>(FORMAT = 0, BPO/UPO = 0) |
|------------------|------------------|-------------------------|--|
| 0                | 0                | 0                       | 0000 0000                                    |
| 128 mV           | 0                | 128 mV                  | 1000 0000                                    |
| 255 mV           | 0                | 255 mV                  | 1111 1111                                    |
| 255 mV           | 255 mV           | 0                       | 0000 0000                                    |
| 128 mV           | 127 mV           | 1 mV                    | 0000 0001                                    |
| 128 mV           | -127 mV          | 255 mV                  | 1111 1111                                    |

Figure 5a. Unipolar Output Codes (Low Range)

| +V <sub>IN</sub> | -V <sub>IN</sub> | DIFF<br>V <sub>IN</sub> | OFFSET BINARY<br>(FORMAT = 0, BPO/UPO = 1) | 2s COMPLEMENT<br>(FORMAT = 1, BPO/UPO = 1) |
|------------------|------------------|-------------------------|--|--|
| 0                | 0                | 0                       | 1000 0000                                  | 0000 0000                                  |
| 127 mV           | 0                | 127 mV                  | 1111 1111                                  | 0111 1111                                  |
| 1.127 V          | 1.000 V          | 127 mV                  | 1111 1111                                  | 0111 1111                                  |
| 255 mV           | 255 mV           | 0                       | 1000 0000                                  | 0000 0000                                  |
| 128 mV           | 127 mV           | 1 mV                    | 1000 0001                                  | 0000 0001                                  |
| 127 mV           | 128 mV           | -1 mV                   | 0111 1111                                  | 1111 1111                                  |
| 127 mV           | 255 mV           | -128 mV                 | 0000 0000                                  | 1000 0000                                  |
| -128 mV          | 0                | -128 mV                 | 0000 0000                                  | 1000 0000                                  |

Figure 5b. Bipolar Output Codes (Low Range)

### Calibration

Because of its precise factory calibration, the AD670 is intended to be operated without user trims for gain and offset; therefore, no provisions have been made for such user trims. Figures 6a, 6b, and 6c show the transfer curves at zero and full scale for the unipolar and bipolar modes. The code transitions are positioned so that the desired value is centered at that code. The first LSB transition for the unipolar mode occurs for an input of +1/2 LSB (5 mV or 0.5 mV). Similarly, the MSB transition for the bipolar mode is set at -1/2 LSB (-5 mV or -0.5 mV). The full scale transition is located at the full scale value -1 1/2 LSB. These values are 2.545 V and 254.5 mV.

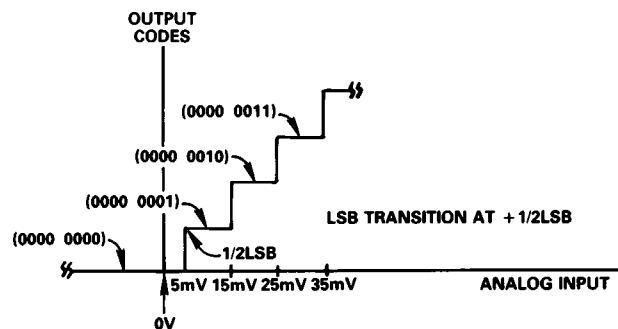

6a. Unipolar Transfer Curve

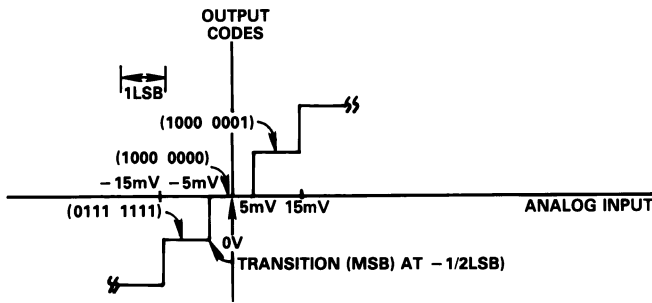

6b. Bipolar

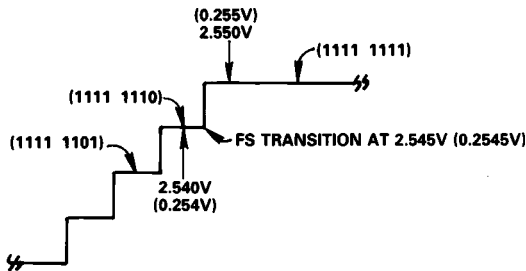

6c. Full Scale (Unipolar)  
Figure 6. Transfer Curves

**CONTROL AND TIMING OF THE AD670**

**Control Logic**

The AD670 contains on-chip logic to provide conversion and data read operations from signals commonly available in microprocessor systems. Figure 7 shows the internal logic circuitry of the AD670. The control signals,  $\overline{CE}$ ,  $\overline{CS}$ , and  $R/\overline{W}$  control the operation of the converter. The read or write function is determined by  $R/\overline{W}$  when both  $\overline{CS}$  and  $\overline{CE}$  are low as shown in Table II. If all three control inputs are held low longer than the conversion time, the device will continuously convert until one input,  $\overline{CE}$ ,  $\overline{CS}$ , or  $R/\overline{W}$  is brought high. The relative timing of these signals is discussed later in this section.

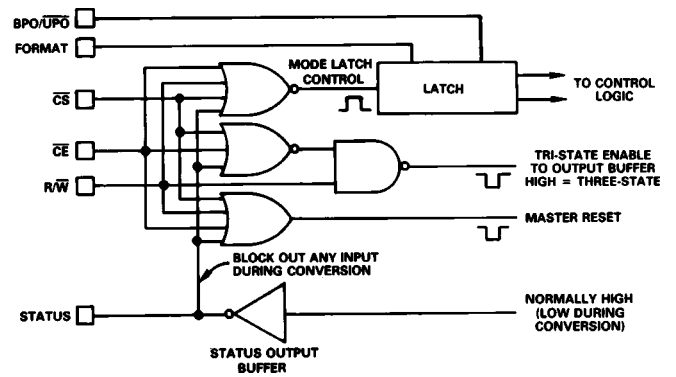

Figure 7. Control Logic Block Diagram

Table II. AD670 Control Signal Truth Table

| R/W | CS | CE | OPERATION     |
|-----|----|----|---------------|
| 0   | 0  | 0  | WRITE/CONVERT |
| 1   | 0  | 0  | READ          |
| X   | X  | 1  | NONE          |
| X   | 1  | X  | NONE          |

**Timing**

The AD670 is easily interfaced to a variety of microprocessors and other digital systems. The following discussion of the timing requirements of the AD670 control signals will provide the designer with useful insight into the operation of the device.

**Write/Convert Start Cycle**

Figure 8 shows a complete timing diagram for the write/convert start cycle.  $\overline{CS}$  (chip select) and  $\overline{CE}$  (chip enable) are active low and are interchangeable signals. Both  $\overline{CS}$  and  $\overline{CE}$  must be low for the converter to read or start a conversion. The minimum pulse width,  $t_w$ , on either  $\overline{CS}$  or  $\overline{CE}$  is 300 ns to start a conversion.

Table III. AD670 TIMING SPECIFICATIONS

| Symbol                          | Parameter                          | @ +25°C |     |            | Units   |
|---------------------------------|------------------------------------|---------|-----|------------|---------|
|                                 |                                    | Min     | Typ | Max        |         |
| <b>WRITE/CONVERT START MODE</b> |                                    |         |     |            |         |
| $t_w$                           | Write/Start Pulse Width            | 300     |     |            | ns      |
| $t_{DS}$                        | Input Data Setup Time              | 200     |     |            | ns      |
| $t_{DH}$                        | Input Data Hold                    | 10      |     |            | ns      |
| $t_{RWC}$                       | Read/Write Setup Before Control    | 0       |     |            | ns      |
| $t_{DC}$                        | Delay to Convert Start             |         |     | 700        | ns      |
| $t_C$                           | <b>Conversion Time</b>             |         |     | <b>10</b>  | $\mu$ s |
| <b>READ MODE</b>                |                                    |         |     |            |         |
| $t_R$                           | Read Time                          | 250     |     |            | ns      |
| $t_{SD}$                        | Delay from Status Low to Data Read |         |     | 250        | ns      |
| $t_{TD}$                        | <b>Bus Access Time</b>             |         | 200 | <b>250</b> | ns      |
| $t_{DH}$                        | Data Hold Time                     | 25      |     |            | ns      |
| $t_{DT}$                        | <b>Output Float Delay</b>          |         |     | <b>150</b> | ns      |
| $t_{RT}$                        | R/W before CE or CS low            | 0       |     |            | ns      |

Boldface indicates parameters tested 100% unless otherwise noted. See Specifications page for explanation.

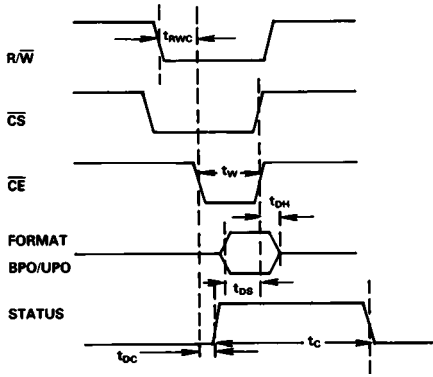

Figure 8. Write/Convert Start Timing

The  $\overline{R/\overline{W}}$  line is used to direct the converter to start a conversion ( $\overline{R/\overline{W}}$  low) or read data ( $\overline{R/\overline{W}}$  high). The relative sequencing of the three control signals ( $\overline{R/\overline{W}}$ ,  $\overline{CE}$ ,  $\overline{CS}$ ) is unimportant. However, when all three signals remain low for at least 300 ns ( $t_w$ ), STATUS will go high to signal that a conversion is taking place.

Once a conversion is started and the STATUS line goes high, convert start commands will be ignored until the conversion cycle is complete. The output data buffer cannot be enabled during a conversion.

**Read Cycle**

Figure 9 shows the timing for the data read operation. The data outputs are in a high impedance state until a read cycle is initiated. To begin the read cycle,  $\overline{R/\overline{W}}$  is brought high. During a read cycle, the minimum pulse length for  $\overline{CE}$  and  $\overline{CS}$  is a function of the length of time required for the output data to be valid. The data becomes valid and is available to the data bus in a maximum of 250 ns. This delay between the high impedance state and valid data is the maximum bus access time or  $t_{TD}$ . Bringing  $\overline{CE}$  or  $\overline{CS}$  high during valid data ends the read cycle. The outputs remain valid for a minimum of 25 ns ( $t_{DH}$ ) and return to the high impedance state after a delay,  $t_{DT}$ , of 150 ns maximum.

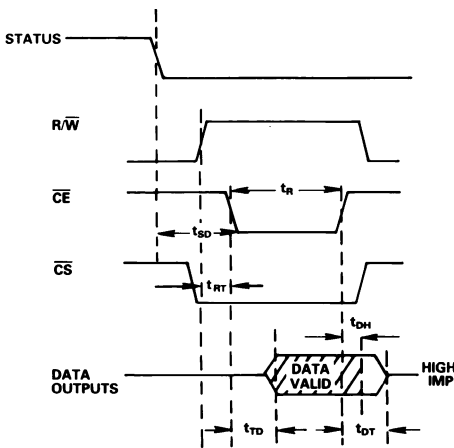

Figure 9. Read Cycle Timing

**STAND-ALONE OPERATION**

The AD670 can be used in a “stand-alone” mode, which is useful in systems with dedicated input ports available. Two typical conditions are described and illustrated by the timing diagrams which follow.

**Single Conversion, Single Read**

When the AD670 is used in a stand-alone mode,  $\overline{CS}$  and  $\overline{CE}$  should be tied together. Conversion will be initiated by bringing  $\overline{R/\overline{W}}$  low. Within 700 ns, a conversion will begin. The  $\overline{R/\overline{W}}$  pulse should be brought high again once the conversion has started so that the data will be valid upon completion of the conversion. Data will remain valid until  $\overline{CE}$  and  $\overline{CS}$  are brought high to indicate the end of the read cycle or  $\overline{R/\overline{W}}$  goes low. The timing diagram is shown in Figure 10.

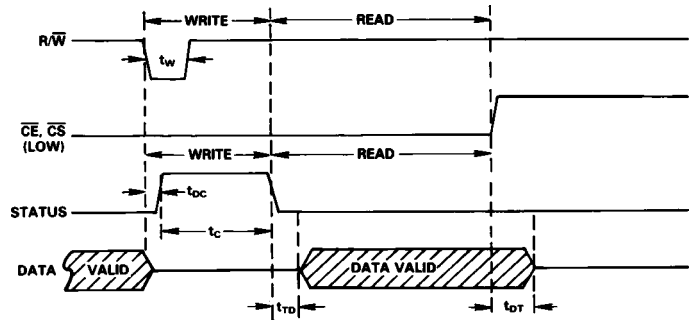

Figure 10. Stand-Alone Mode Single Conversion/Single Read

**Continuous Conversion, Single Read**

A variety of applications may call for the A/D to be read after several conversions. In process control systems, this is often the case since a reading from a sensor may only need to be updated every few conversions. Figure 11 shows the timing relationships.

Once again,  $\overline{CE}$  and  $\overline{CS}$  should be tied together. Conversion will begin when the  $\overline{R/\overline{W}}$  signal is brought low. The device will convert repeatedly as indicated by the status line. A final conversion will take place once the  $\overline{R/\overline{W}}$  line has been brought high. The rising edge of  $\overline{R/\overline{W}}$  must occur while STATUS is high.  $\overline{R/\overline{W}}$  should not return high while STATUS is low since the circuit is in a reset state prior to the next conversion. Since the rising edge of  $\overline{R/\overline{W}}$  must occur while STATUS is high,  $\overline{R/\overline{W}}$ 's length must be a minimum of 10.25  $\mu$ s ( $t_c + t_{TD}$ ). Data becomes valid upon completion of the conversion and will remain so until the  $\overline{CE}$  and  $\overline{CS}$  lines are brought high indicating the end of the read cycle or  $\overline{R/\overline{W}}$  goes low initiating a new series of conversions.

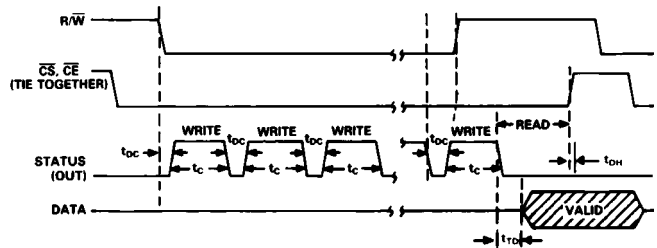

Figure 11. Stand-Alone Mode Continuous Conversion/Single Read

## APPLYING THE AD670

The AD670 has been designed for ease of use, system compatibility, and minimization of external components. Transducer interfaces generally require signal conditioning and preamplification before the signal can be converted. The AD670 will reduce and even eliminate this excess circuitry in many cases. To illustrate the flexibility and superior solution that the AD670 can bring to a transducer interface problem, the following discussions are offered.

### Temperature Measurements

Temperature transducers are one of the most common sources of analog signals in data acquisition systems. These sensors require circuitry for excitation and preamplification/buffering. The instrumentation amplifier input of the AD670 eliminates the need for this signal conditioning. The output signals from temperature transducers are generally sufficiently slow that a sample/hold amplifier is not required. Figure 12 shows the AD590 IC temperature transducer interfaced to the AD670. The AD580 voltage reference is used to offset the input for 0°C calibration. The current output of the AD590 is converted into a voltage by R1. The high impedance unbuffered voltage is applied directly to the AD670 configured in the -128 mV to 127 mV bipolar range. The digital output will have a resolution of 1°C.

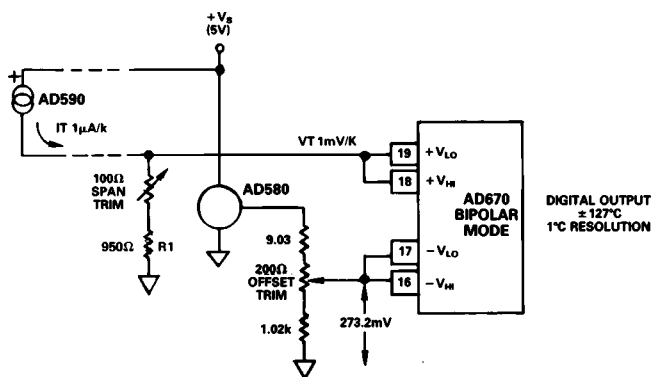

Figure 12. AD670 Temperature Transducer Interface

Platinum RTDs are also a popular, temperature transducer. Typical RTDs have a resistance of 100 Ω at 0°C and change resistance 0.4 Ω per °C. If a constant excitation current is caused to flow in the RTD, the change in voltage drop will be a measure of the change in temperature. Figure 13 shows such a method and the required connections to the AD670. The AD580 2.5 V reference provides the accurate voltage for the excitation current and range offsetting for the RTD. The op amp is configured to force a constant 2.5 mA current through the RTD. The differential inputs of the AD670 measure the difference between a fixed offset voltage and the temperature dependent output of the op amp which varies with the resistance of the RTD. The RTD change of approximately 0.4 Ω/°C results in a 1 mV/°C voltage change. With the AD670 in the 1 mV/LSB range, temperatures from 0°C to 255°C can be measured.

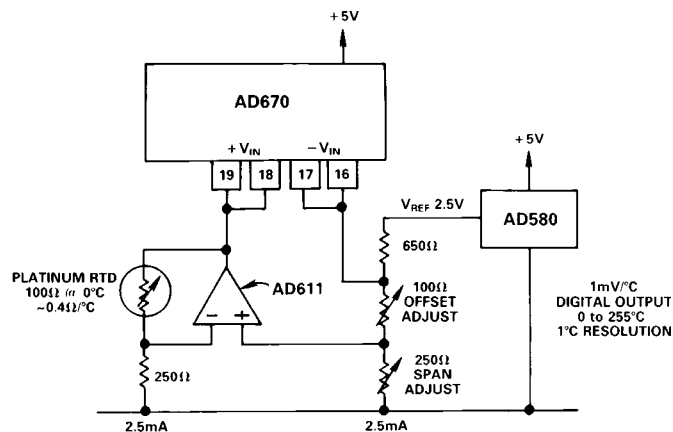

Figure 13. Low Cost RTD Interface

Differential temperature measurements can be made using an AD590 connected to each of the inputs as shown in Figure 14. This configuration will allow the user to measure the relative temperature difference between two points with a 1°C resolution. Although the internal 1k and 9k resistors on the inputs have ±20% tolerance, trimming the AD590 is unnecessary as most differential temperature applications are concerned with the relative differences between the two. However, the user may see up to a 20% scale factor error in the differential temperature to digital output transfer curve.

This scale factor error can be eliminated through a software correction. Offset corrections can be made by adjusting for any difference that results when both sensors are held at the same temperature. A span adjustment can then be made by immersing one AD590 in an ice bath and one in boiling water and eliminating any deviation from 100°C. For a low cost version of this setup, the plastic AD592 can be substituted for the AD590.

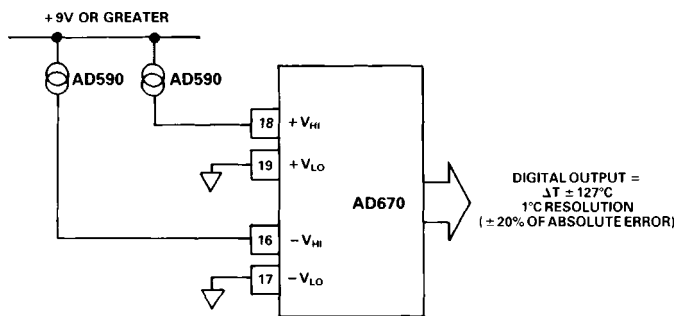

Figure 14. Differential Temperature Measurement Using the AD590

# AD670

## STRAIN GAGE MEASUREMENTS

Many semiconductor-type strain gages, pressure transducers, and load cells may also be connected directly to the AD670. These types of transducers typically produce 30 mV full-scale per volt of excitation. In the circuit shown in Figure 15, the AD670 is connected directly to a Data Instruments model JP-20 load cell. The AD584 programmable voltage reference is used along with an AD741 op amp to provide the  $\pm 2.5$  V excitation for the load cell. The output of the transducer will be  $\pm 150$  mV for a force of  $\pm 20$  pounds. The AD670 is configured for the  $\pm 128$  millivolt range. The resolution is then approximately 2.1 ounces per LSB over a range of  $\pm 17$  pounds. Scaling to exactly 2 ounces per LSB can be accomplished by trimming the reference voltage which excites the load cell.

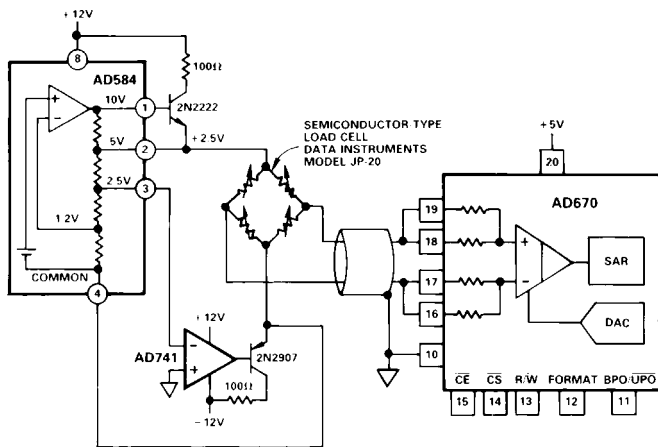

Figure 15. AD670 Load Cell Interface

## MULTIPLEXED INPUTS

Most data acquisition systems require the measurement of several analog signals. Multiple A/D converters are often used to digitize these inputs, requiring additional preamplification and buffer stages per channel. Since these signals vary slowly, a differential MUX can multiplex inputs from several transducers into a single AD670. And since the AD670's signal-conditioning capability is preserved, the cost of several ADCs, differential amplifiers, and other support components can be reduced to that of a single AD670, a MUX, and a few digital logic gates.

An AD7502 dual 4-channel MUX appears in Figure 16 multiplexing four differential signals to the AD670. The AD7502's decoded address is gated with the microprocessor's write signal to provide a latching strobe at the flip-flops. A write cycle to the AD7502's address then latches the two LSBs of the data word thereby selecting the input channel for subsequent conversions.

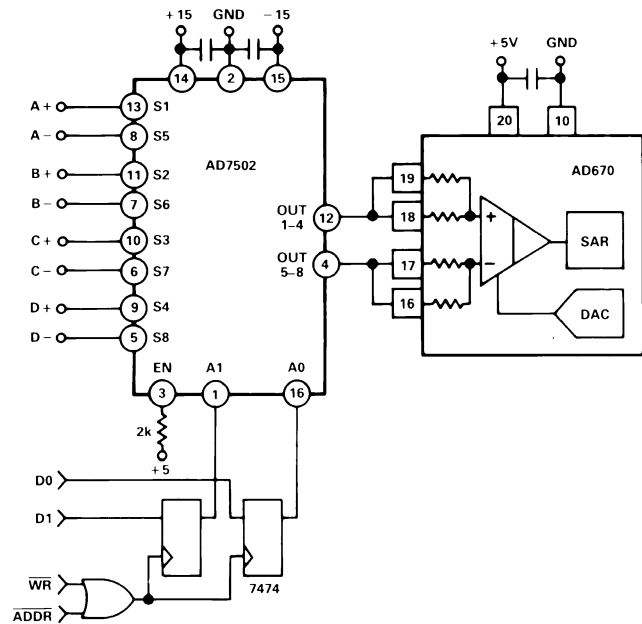

Figure 16. Multiplexed Analog Inputs to AD670

## SAMPLED INPUTS

For those applications where the input signal is capable of slewing more than 1/2 LSB during the AD670's 10  $\mu$ s conversion cycle, the input should be held constant for the cycle's duration. The circuit shown in Figure 17 uses a CMOS switch and two capacitors to sample/hold the input. The AD670's STATUS output, once inverted, supplies the sample/hold ( $S/\bar{H}$ ) signal.

A convert command applied on the  $\overline{CE}$ ,  $\overline{CS}$  or  $R/\overline{W}$  lines will initiate the conversion. The AD670's STATUS output, once inverted, supplies the sample/hold signal to the CD4066. The CD4066 CMOS switch shown in Figure 17 was chosen for its fast transition times, low on-resistance and low cost. The control input's propagation delay for switch-closed to switch-open should remain less than 150 ns to ensure that the sample-to-hold transition occurs before the first bit decision in the AD670.

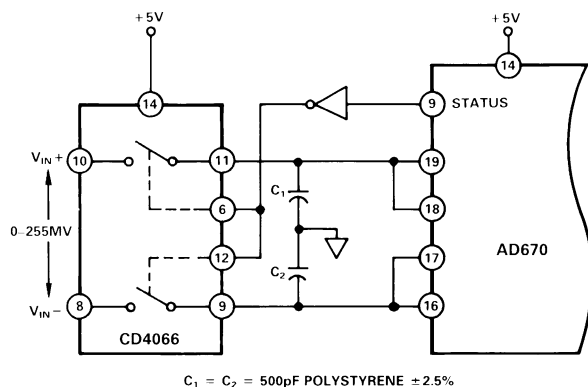

Figure 17. Low Cost Sample-and-Hold Circuit for AD670

Since settling to 1/2 LSB at 8-bits of resolution requires 6.2 RC time constants, the 500 pF hold capacitors and CD4066's 300 Ω on-resistance yield an acquisition time of under 1 μs, assuming a low impedance source.

This sample/hold approach makes use of the differential capabilities of the AD670. Because 500 pF hold capacitors are used on both  $V_{IN+}$  and  $V_{IN-}$  inputs, the droop rate depends only on the offset current of the AD670, typically 20 nA. With the matched 500 pF capacitors, the droop rate is 40 μV/μs. The input will then droop only 0.4 mV (0.4 LSB) during the AD670's 10 μs conversion time. The differential approach also minimizes pedestal error since only the difference in charge injection between the two switches results in errors at the A/D.

The fast conversion time and differential and common-mode capabilities of the AD670 permit this simple sample-hold design to perform well with low sample-to-hold offset, droop rate of about 40 μV/μs and acquisition time under 1 μs. The effective aperture time of the AD670 is reduced by about 2 orders of magnitude with this circuit, allowing frequencies to be converted up to several kilohertz.

While no input anti-aliasing filter is shown, filtering will be necessary to prevent output errors if higher frequencies are present in the input signal. Many practical variations are possible with this circuit, including input MUX control, for digitizing a number of ac channels.

### IBM PC INTERFACE

The AD670 appears in Figure 18 interfaced to the IBM PC. Since the device resides in I/O space, its address is decoded from only the lower ten address lines and must be gated with AEN (active low) to mask out internal (DMA) cycles which use the same I/O address space. This active low signal is applied to  $\overline{CS}$ . AO, meanwhile, is reserved for the  $R/\overline{W}$  input. This places the AD670 in two adjacent addresses; one for starting the conversion and the other for reading the result. The IOR and  $\overline{IOW}$  signals are then gated and applied to  $\overline{CE}$ , while the lower two data lines are applied to FORMAT and  $BPO/\overline{UPO}$  inputs to provide software programmable input formats and output coding.

In BASIC, a simple OUT ADDR, WORD command initiates a conversion. While the upper six bits of the data WORD are meaningless, the lower two bits define the analog input format and digital output coding according to Table IV. The data is available ten microseconds later (which is negligible in BASIC) and can be read using INP (ADDR + 1). The 3-line subroutine in Figure 19, used in conjunction with the interface of Figure 18, converts an analog input within a bipolar range to an offset binary coded digital word.

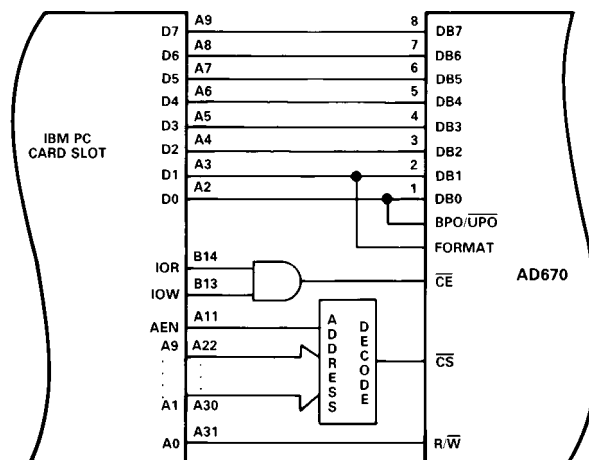

Figure 18. IBM PC Interface to AD670

NOTE: Due to the large number of options that may be installed in the PC, the I/O bus loading should be limited to one Schottky TTL load. Therefore, a buffer/driver should be used when interfacing more than two AD670s to the I/O bus.

Table IV.

| Data | Input Format | Output Coding   |
|------|--------------|-----------------|
| 0    | Unipolar     | Straight Binary |
| 1    | Bipolar      | Offset Binary   |
| 2    | Unipolar     | 2s Complement   |
| 3    | Bipolar      | 2s Complement   |

```

10 OUT &H310,1          'INITIATE CONVERSION
20 ANALOGIN = INP (&H311) 'READ ANALOG INPUT
30 RETURN
    
```

Figure 19. Conversion Subroutine

OUTLINE DIMENSIONS

Dimensions shown in inches and (mm).

20-Pin Plastic DIP (N-20)

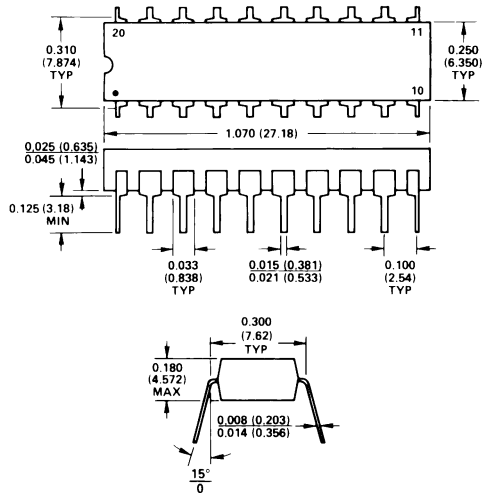

20-Pin Ceramic DIP (D-20)

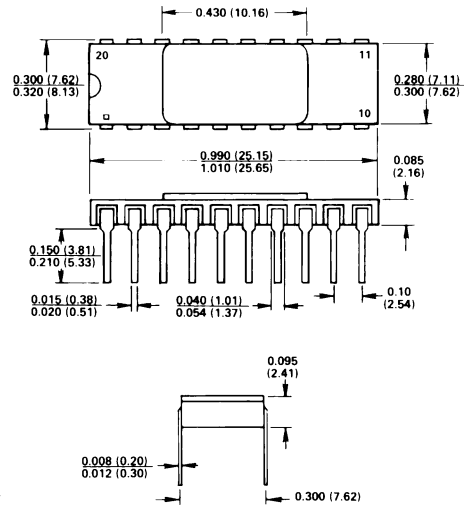

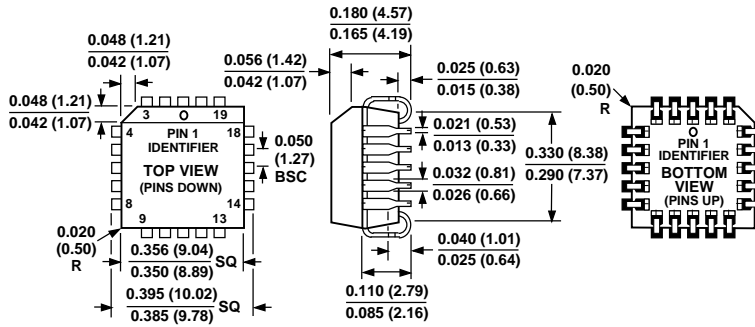

LEAD NO. 1 IDENTIFIED BY DOT OR NOTCH.

20-Terminal PLCC Package (P-20A)



## Looking for pricing, stock, or lifecycle information?

Click below to explore more details on WIN SOURCE:

-  [View AD670KN on WIN SOURCE](#)
-  [Analog Devices Inc. Information](#)

## Optimize Your Supply Chain with WIN SOURCE Solutions

-  Global Sourcing Solution
-  Obsolete Management
-  Cost Control Management
-  Shortage Management
-  Alternative Solution
-  Excess Inventory Management